



Mass flow controller (MFC)/mass flow meter (MFM) for gases

- Nominal flow range from 0.01 I_N/min to 100 I_N/min (ref. nitrogen)
- High accuracy in measurement and repeatability
- Suitable for aggressive gases
- User-friendly gas conversion
- Easy device exchange due to configuration memory

Product variants described in the data sheet may differ from the product presentation and description.

Can be combined with

	Type 7011 Direct-acting 2/2-way plunger valve	▶
	Type 6013 Plunger valve 2/2-way direct-acting	▶
	Type 0330 Direct-acting 2/2 or 3/2-way pivoted armature valve	▶
	Type ME43 Fieldbus gateway	▶
	Type ME63 Industrial Ethernet gateway, IP65/IP67/IP69k	▶
	Type ME61 EDIP process display	▶
	Type ME66 Passive junction box, IP65/IP67/ IP69k	▶

Type description

The Type 8744 mass flow controller (MFC)/mass flow meter (MFM) is suitable for controlling or measuring aggressive gases, gas mixtures and in the area of application for alternating gases. A thermal capillary sensor, with non-wetted sensor elements, is used for this. This also enables easy conversion to the process gas in question. The wetted parts are made of high-quality stainless steel and FFKM as seal material for high chemical resistance. The MFC variant achieves high control accuracy thanks to the use of Bürkert proportional valve technology and the application-appropriate layout of the valve orifice. The MFC can be implemented with low pressure loss as required, due to the diversity of the available valve orifices. These MFCs and MFMs either communicate the set-point and actual values of the flow value via an analogue interface, or other values, as well as the set-point and actual values, that can be selected via software via an Industrial Ethernet interface. Type 8744 represents the IP65 variant of the Type 8743 and contains the CAN-based büS variant for integration into CAN or büS networks. A wide range of devices can easily and efficiently be integrated into the control level in this way via an Ethernet gateway. The communication data is configured via the Bürkert Communicator software.

Table of contents

1. General technical data	3
2. Approvals and conformities	4
2.1. General notes	4
2.2. Conformity	4
2.3. Standards	4
2.4. Explosion protection.....	4
2.5. North America (USA/Canada)	5
2.6. Foods and beverages/Hygiene	5
2.7. Oxygen	5
3. Materials	5
3.1. Bürkert resistApp	5
4. Dimensions	6
4.1. Threaded variant connections	6
Small nominal flow rates < 20 l _N /min, with internal thread	6
Small nominal flow rates < 20 l _N /min, compatible with VCR®	6
Small nominal flow rates < 20 l _N /min, with clamp connection DN 15...½"	6
Large flow rates > 20 l _N /min, with internal thread	7
4.2. Variant with büS/CANopen interface	7
MFC with valve Type 2871 for nominal flow rates < 20 l _N /min.....	7
MFC with valve Type 2871 for nominal flow rates > 20 l _N /min.....	9
MFC with valve Type 2873 for nominal flow rates > 20 l _N /min	11
MFM for nominal flow rates < 20 l _N /min	13
MFM for nominal flow rates > 20 l _N /min	14
5. Product connections	15
5.1. Communication	15
büS/CANopen	15
PROFIBUS DPV1.....	15
6. Performance specifications	16
6.1. MFM pressure loss diagram	16
7. Product operation	16
7.1. Measurement principle	16
8. Product accessories	17
8.1. Bürkert Communicator software	17
8.2. Connecting Type 8744 with the Bürkert Communicator software	18
8.3. Configuration management for easy device replacement.....	18
9. Ordering information	18
9.1. Bürkert eShop	18
9.2. Recommendation regarding product selection.....	18
9.3. Bürkert product filter.....	19
9.4. Bürkert Product Enquiry Form	19
9.5. Ordering chart accessories.....	19

DTS 1000592376 EN Version: I Status: RL (released | freigegeben | valide) printed: 22.10.2025



1. General technical data

Product properties	
Dimensions	Further information can be found in chapter "4. Dimensions" on page 6.
Material	
Seal	FKM, EPDM and FFKM, PCTFE seat seal for nominal diameters DN 0.05 and DN 0.1
Housing	Aluminium die casting (painted)
Base block	Stainless steel 1.4404/316L
Wetted parts	Stainless steel 1.4401/316, 1.4404/316L, 1.4435/316L, PCTFE and seal material
Total weight	Variant for nominal flow rates < 20 l/min: • Approx. 800 g (MFM, without valve) • Approx. 1100 g (MFC with valve Type 2871) Variant for nominal flow rates > 20 l/min: • Approx. 1000 g (MFM, without valve) • Approx. 1500 g (MFC with valve Type 2871) • Approx. 1600 g (MFC with valve Type 2873)
Configuration management	Further information can be found in chapter "8.3. Configuration management for easy device replacement" on page 18.
LED display ¹⁾	RGB LED according to NAMUR NE107
Performance data	
Nominal flow range (Q_N) ²⁾	10 ml _N /min...100 l _N /min (N ₂) ²⁾
Operating pressure ³⁾	MFM: max. 10 bar For MFCs, the maximum operating pressure depends on the medium and nominal valve size.
Measuring accuracy ⁴⁾	± 0.8 % MV ⁵⁾ ± 0.3 % FS ⁶⁾ (under calibration conditions and after < 30 min warm-up time to achieve the best measuring conditions)
Repeatability	± 0.1 % FS
Turndown ratio	1:20 at $Q_N < 25$ ml/min, 1:50 at $Q_N > 25$ ml/min (higher on request) ²⁾
Temperature coefficient	± (0.05 % FS + 0.05 % MV)/K (deviation from gas temperature during calibration and adjustment)
Pressure coefficient	± 0.1 % MV/bar (deviation from operating pressure during calibration and adjustment, referring to N ₂)
Settling time (MFC)/Response time (MFM) (t95)	< 2 s
Actuator (proportional valve)	
Nominal diameter	0.05...4 mm
K _{vs} value range	0.00006...0.32 m ³ /h
Electrical data	
Operating voltage	24 V DC
Power consumption ⁷⁾	MFM: 1...2 W MFC: max. 3...18 W (depending on the type of proportional valve)
Residual ripple	± 2 %
Voltage tolerance	± 10 %
Electrical connection	
büS/CANopen	M12 plug, 5-pin
PROFIBUS DPV1 variant	M12 plug, 5-pin, M12 socket, 5-pin
Medium data	
Operating medium	Aggressive and neutral, pure gases (others on request)
Calibration medium	Nitrogen
Medium temperature	-10 °C...+ 50 °C
Product connections	
Digital communication interface	büS/CANopen, PROFIBUS DPV1
Port connection	G ¼, NPT ¼, compatible with VCR® ¼, compression fitting, clamp connection (others on request)
Approvals and conformities	
Certificate	Material certificate 3.1 (optionally)
Explosion protection	Further information can be found in chapter "2.4. Explosion protection" on page 4.
North America (USA/Canada)	Further information can be found in chapter "2.5. North America (USA/Canada)" on page 5.
Foods and Beverages/Hygiene	Further information can be found in chapter "2.5. North America (USA/Canada)" on page 5.
Oxygen	Further information can be found in chapter "2.7. Oxygen" on page 5.

Environment and installation	
Installation position	Horizontal or vertical ^{B)}
Storage temperature	- 10 °C...+ 70 °C
Relative air humidity	Max. 95 % at + 55 °C, non-condensing
Degree of protection	IP65
Ambient temperature	- 10 °C...+ 40 °C (higher temperatures on request)
Accessories	
Software	Bürkert Communicator Further information can be found in chapter “8.1. Bürkert Communicator software” on page 17.

- 1.) For a detailed description of LED colours see **operating instructions Type 8744** ▶
- 2.) Index N: flow rates with respect to 1.013 bar abs and 0 °C
- 3.) Overpressure to atmospheric pressure
- 4.) If the operating medium differs from the calibration medium, the actual measuring accuracy may deviate from the specified value. If natural gas is used as the operating medium, the measuring accuracy depends on the composition of the natural gas, which can vary depending on origin and season.
- 5.) Of measured value
- 6.) Of full scale
- 7.) Information based on the typical power consumption (at + 23 °C ambient temperature, nominal flow rate and 30 min closed-loop control mode). The specifications according to UL 61010 - 1 may deviate (see **operating instructions Type 8744** ▶).
- 8.) Calibrated in horizontal installation position, Zero-point adjustment is necessary when choosing a different installation position.

2. Approvals and conformities

2.1. General notes

- The approvals and conformities listed below must be stated when making enquiries. This is the only way to ensure that the product complies with all required specifications.
- Not all available variants can be supplied with the below mentioned approvals or conformities.



2.2. Conformity

In accordance with the Declaration of Conformity, the product is compliant with the EU Directives.

2.3. Standards

The applied standards which are used to demonstrate compliance with the EU Directives are listed in the EU-Type Examination Certificate and/or the EU Declaration of Conformity.

2.4. Explosion protection

Approval	Description
 	Optional: Explosion protection ATEX: EPS 22 ATEX 1 277 X II 3G Ex ec IIC T4 Gc II 3D Ex tc IIIC T135 °C Dc IECEX: IECEX EPS 22.0066X Ex ec IIC T4 Gc Ex tc IIIC T135 °C Dc

DTS 1000592376 EN Version: | Status: RL (released | freigegeben | valide) printed: 22.10.2025

2.5. North America (USA/Canada)

Approval	Description
	<p>Optional: UL Listed for the USA and Canada The products are UL Listed for the USA and Canada according to:</p> <ul style="list-style-type: none"> • UL 61010-1 (ELECTRICAL EQUIPMENT FOR MEASUREMENT, CONTROL, AND LABORATORY USE – Part 1: General Requirements) • CAN/CSA-C22.2 No. 61010-1

2.6. Foods and beverages/Hygiene

Conformity	Description
FDA	<p>FDA – Code of Federal Regulations (valid for variable code PL02, PL03) All wetted materials are compliant with the Code of Federal Regulations published by the FDA (Food and Drug Administration, USA) according to the manufacturer's declaration.</p>
USP	<p>United States Pharmacopeial Convention (USP) (valid for variable code PL04) All wetted materials are biocompatible according to the manufacturer's declaration.</p>
	<p>EC Regulation 1935/2004 of the European Parliament and of the Council (valid for variable code PL01, PL02) All wetted materials are compliant with EC Regulation 1935/2004/EC according to the manufacturer's declaration.</p>

2.7. Oxygen

Conformity	Description
O ₂	<p>Optional: Suitability for oxygen (valid for the variable code NL02) The products are suitable for use with gaseous oxygen, according to the manufacturer's declaration.</p>

3. Materials

3.1. Bürkert resistApp

Bürkert resistApp – Chemical Resistance Chart

You want to ensure the reliability and durability of the materials in your individual application case? Verify your combination of media and materials on our website or in our resistApp.

Start chemical resistance check

DTS 1000592376 EN Version: | Status: RL (released | freigegeben | valide) printed: 22.10.2025

4. Dimensions

4.1. Threaded variant connections

Small nominal flow rates $< 20 \text{ l}_N/\text{min}$, with internal thread

Abmessungen	Gewinde (A)	Gewindetiefe [mm]
	G ¼	12
	NPT ¼	12

Small nominal flow rates $< 20 \text{ l}_N/\text{min}$, compatible with VCR®

Note:

Dimensions in mm

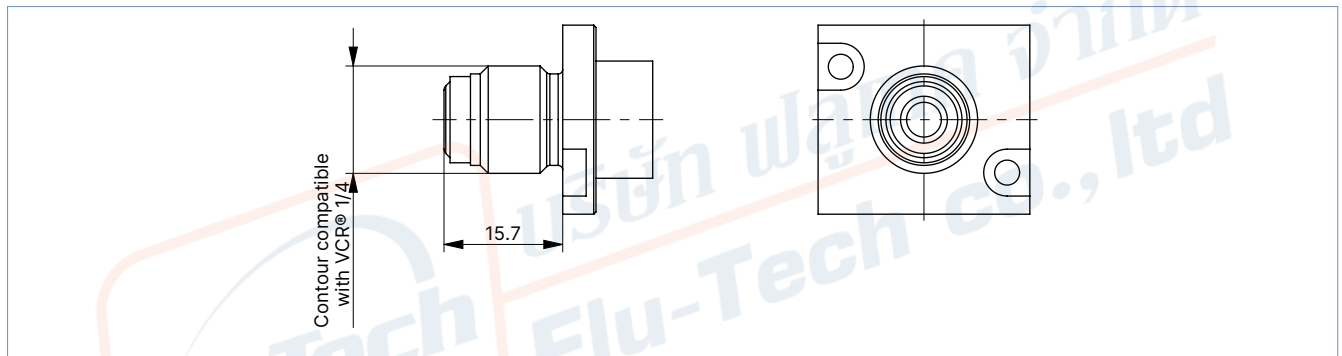

Small nominal flow rates $< 20 \text{ l}_N/\text{min}$, with clamp connection DN 15...½"

Note:

Dimensions in mm

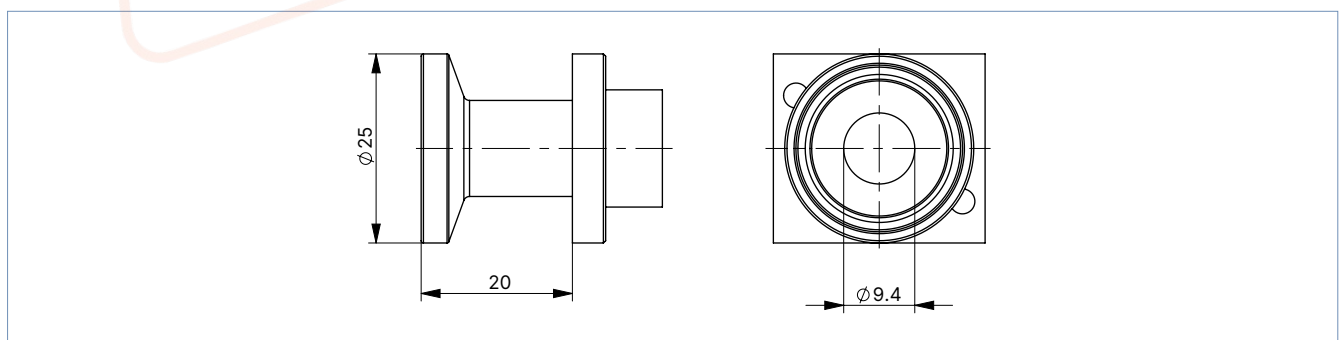

DTS 1000592376 EN Version: | Status: RL (released | freigegeben | valide) printed: 22.10.2025

Large flow rates > 20 l_N/min, with internal thread

Dimensions	Thread (A)	Thread depth [mm]
	G ¼	12.5
	NPT ¼	10
	G ⅜	12.5
	NPT ⅜	11
	G ½	15
	NPT ½	14

4.2. Variant with büS/CANopen interface

MFC with valve Type 2871 for nominal flow rates < 20 l_N/min

NPT/G ¼ variant

Note:

Dimensions in mm

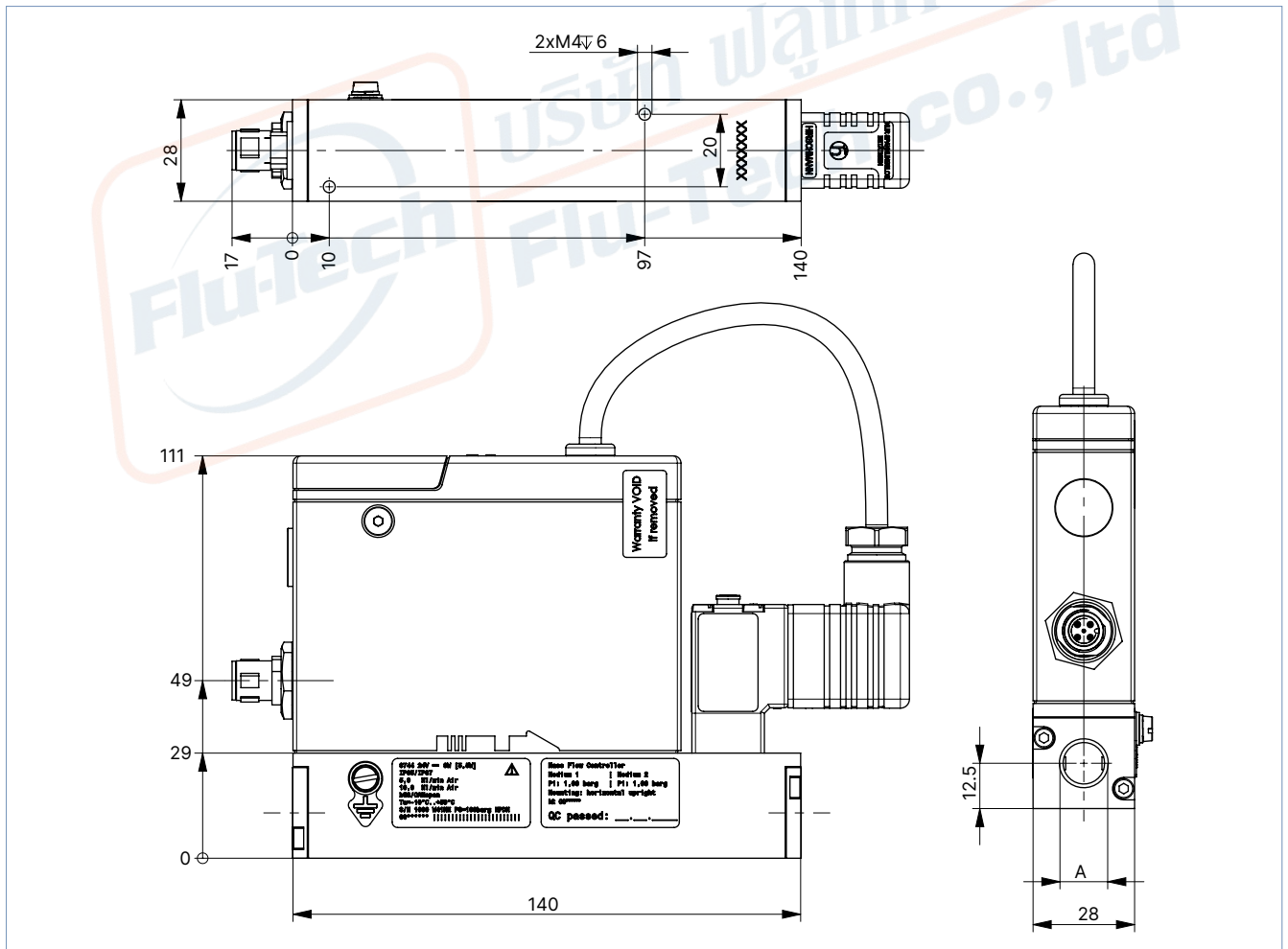

DTS 1000592376 EN Version: | Status: RL (released | freigegeben | valide) printed: 22.10.2025

Sub-base variant

Note:

Dimensions in mm

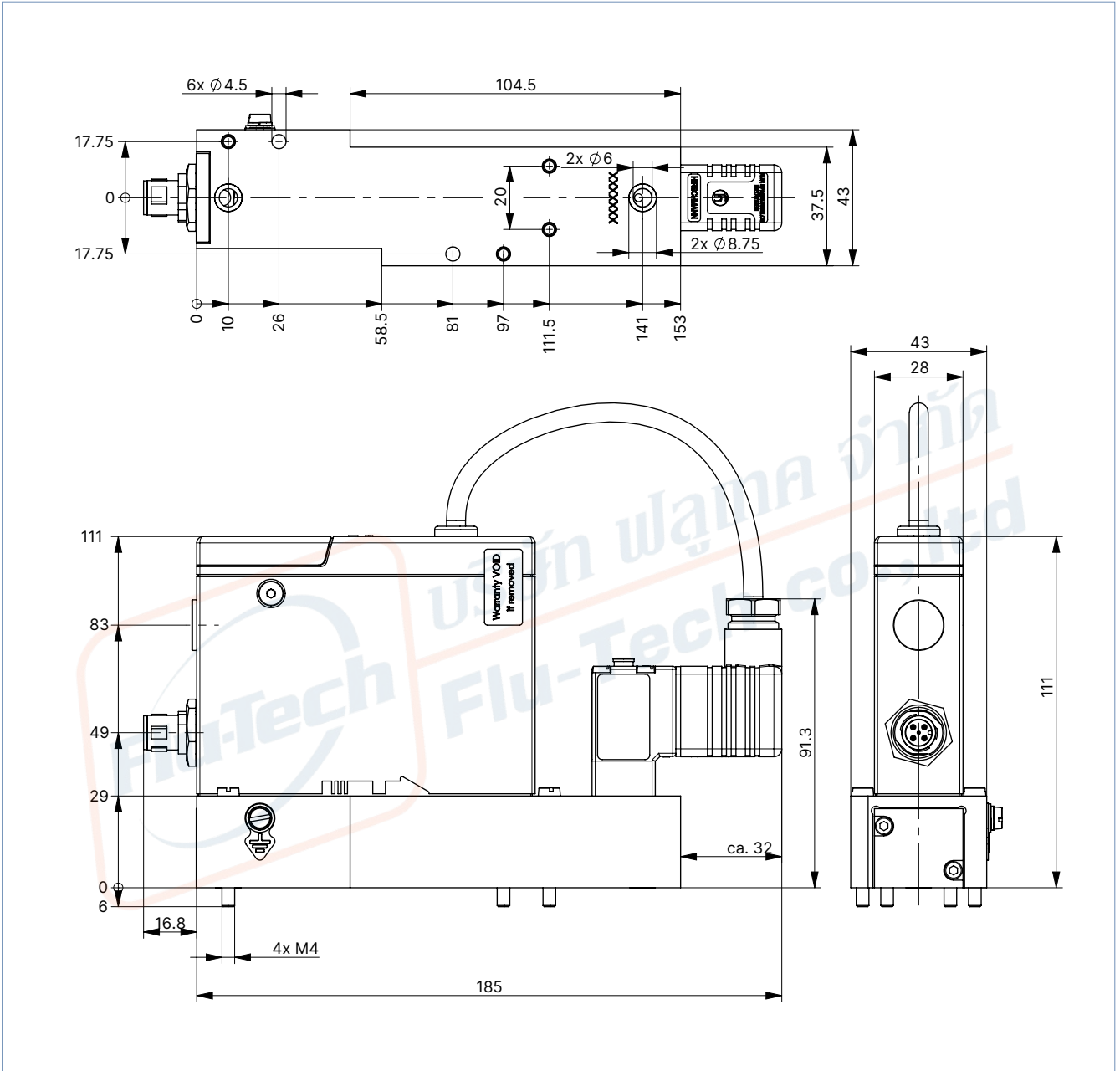

DTS 1000592376 EN Version: | Status: RL (released | freigegeben | valide) printed: 22.10.2025

MFC with valve Type 2871 for nominal flow rates > 20 l_N/min

NPT/G ¼ variant

Note:

Dimensions in mm

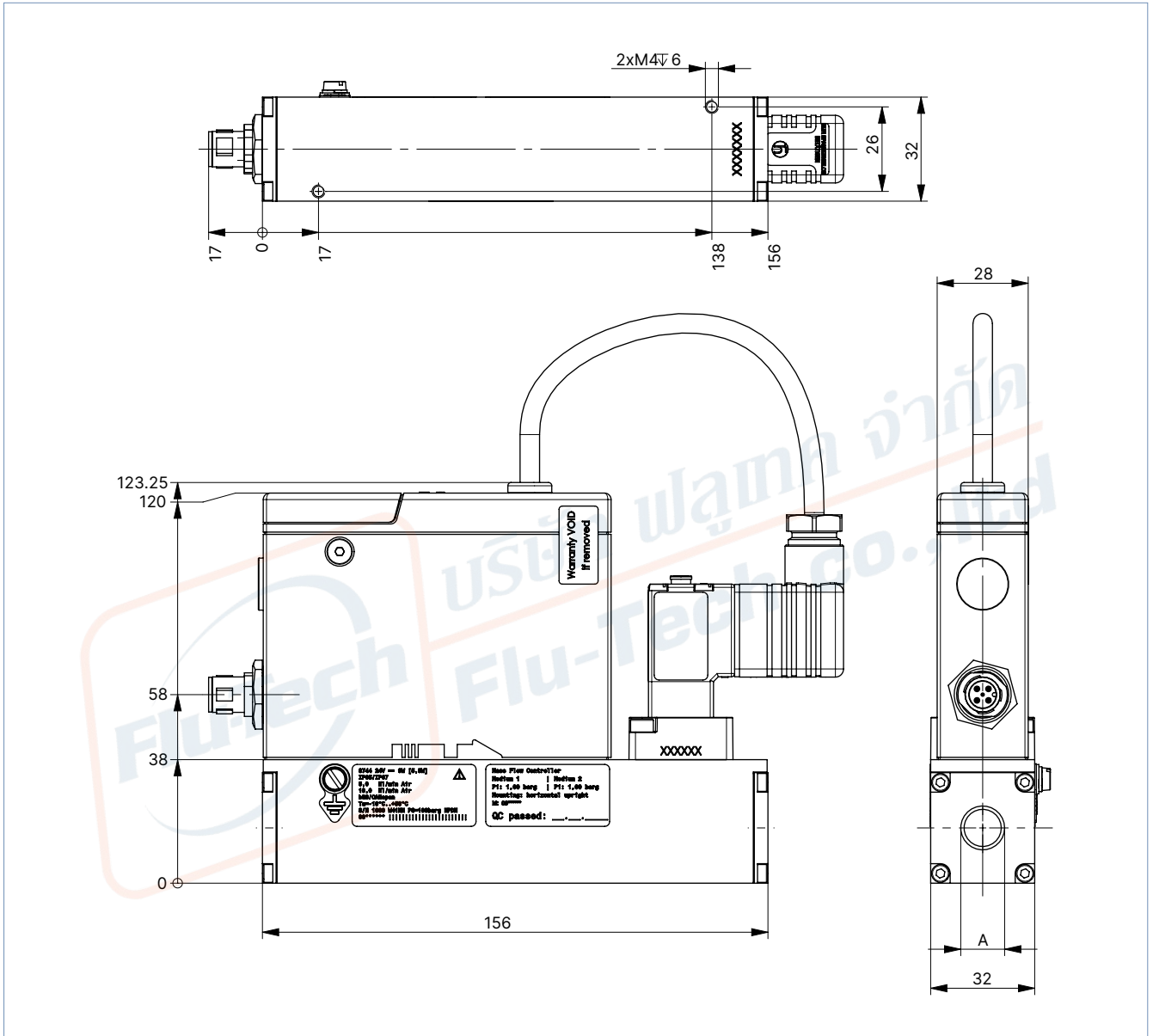

DTS 1000592376 EN Version: | Status: RL (released | freigegeben | valide) printed: 22.10.2025

Sub-base variant

Note:

Dimensions in mm

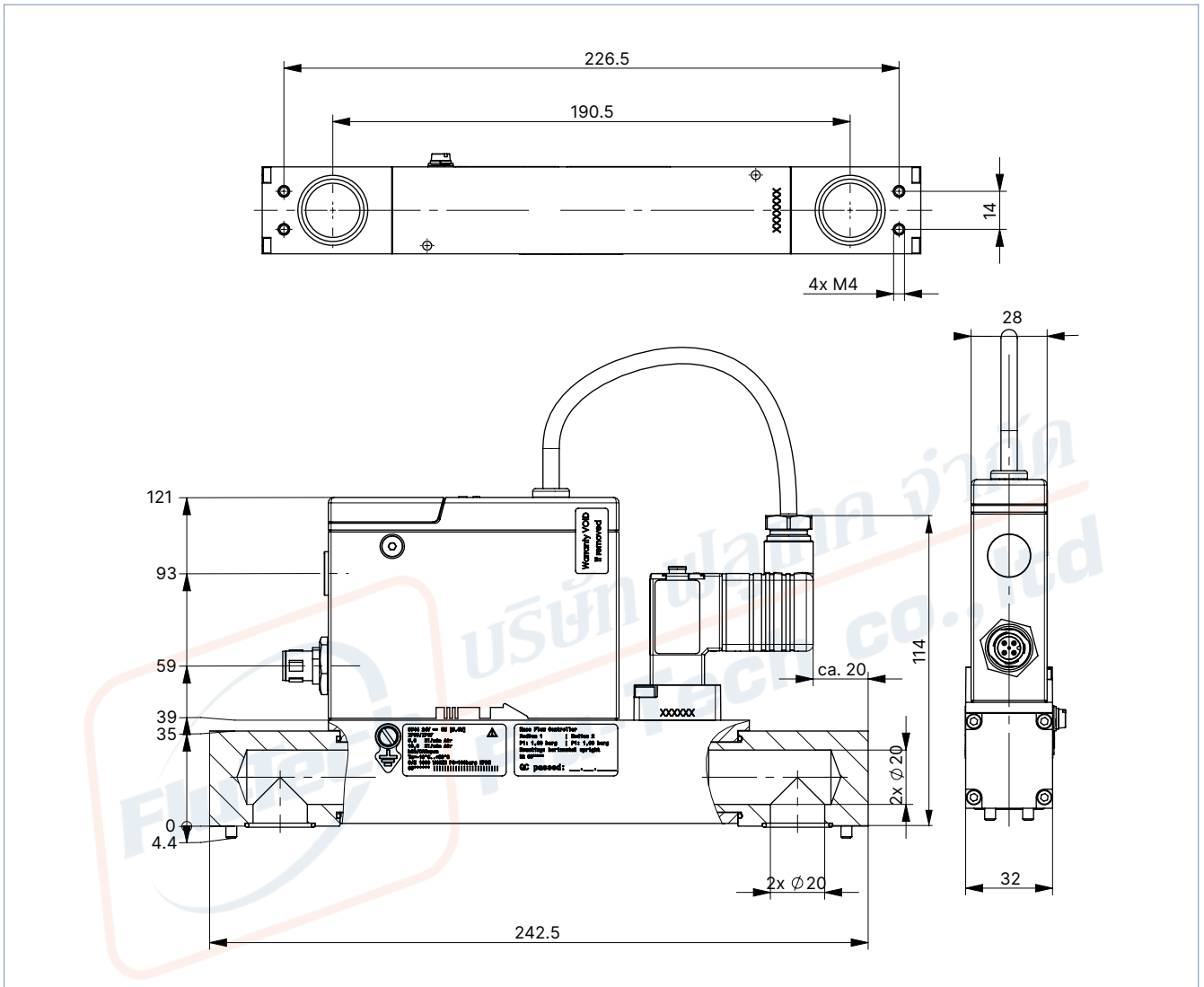

DTS 1000592376 EN Version: | Status: RL (released | freigegeben | valide) printed: 22.10.2025

MFC with valve Type 2873 for nominal flow rates > 20 l_N/min

NPT/G 1/4 variant

Note:

Dimensions in mm

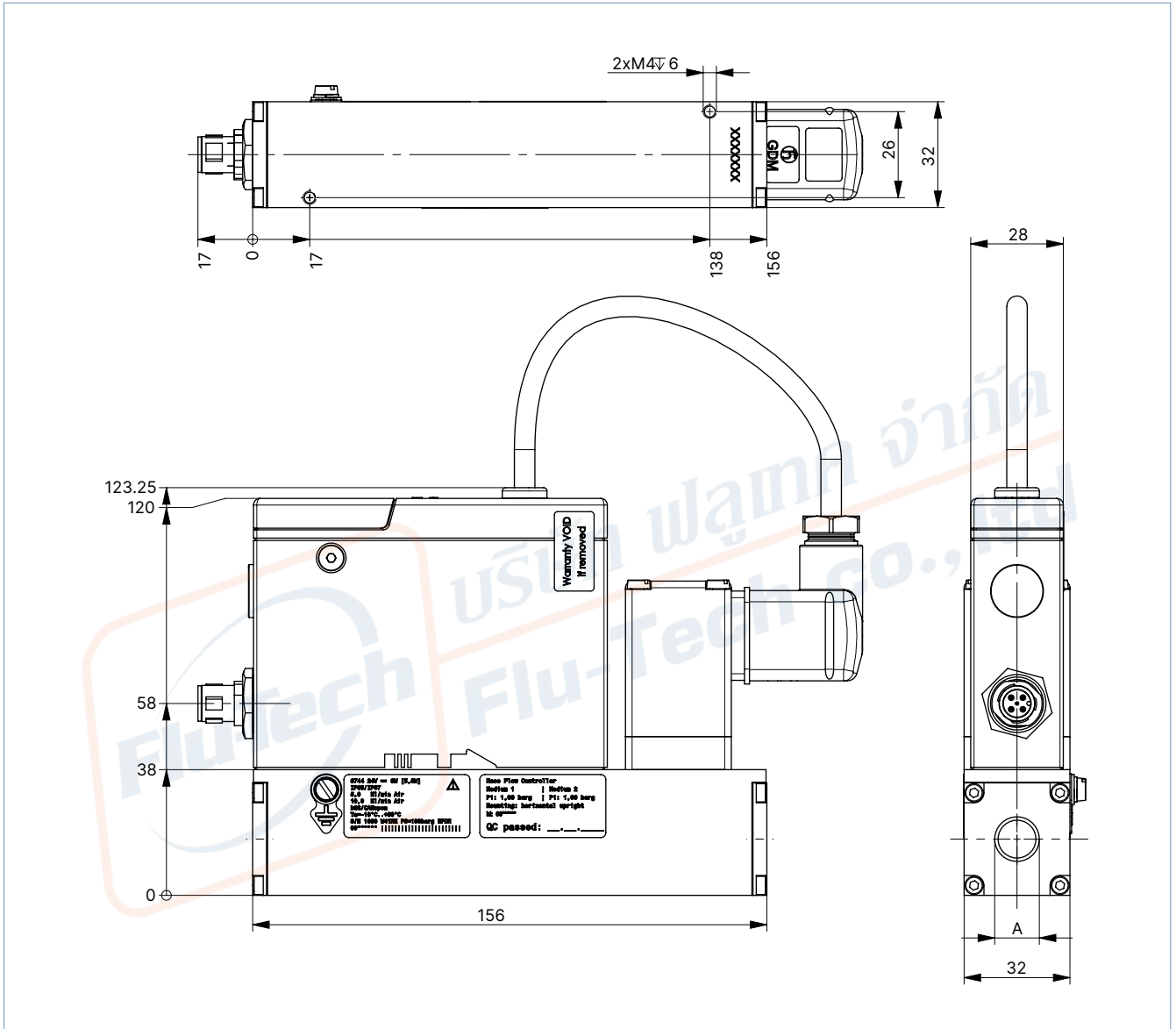

DTS 1000592376 EN Version: | Status: RL (released | freigegeben | valide) printed: 22.10.2025

Sub-base variant

Note:

Dimensions in mm

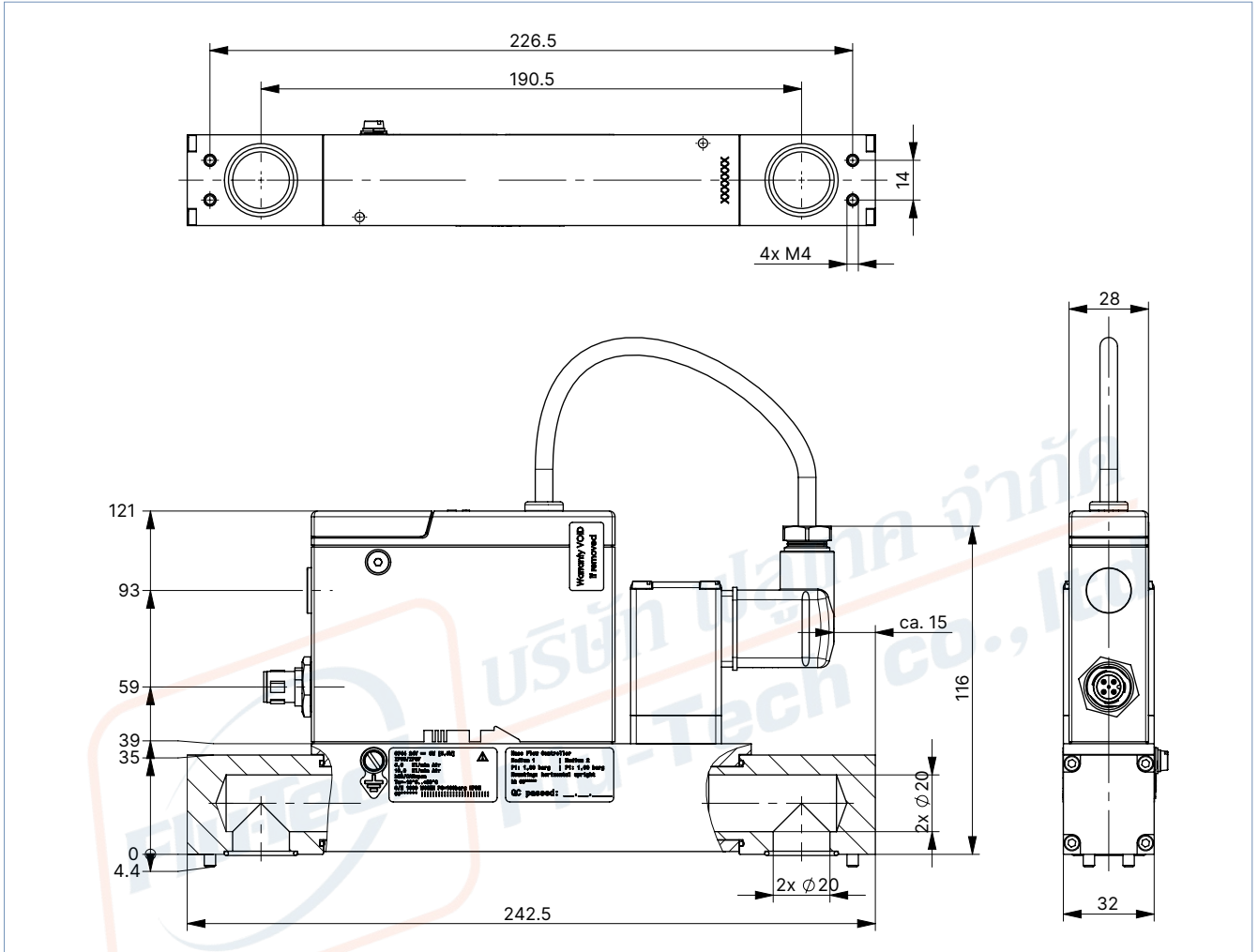

DTS 1000592376 EN Version: | Status: RL (released | freigegeben | valide) printed: 22.10.2025

MFM for nominal flow rates > 20 l_N/min

Note:

Dimensions in mm

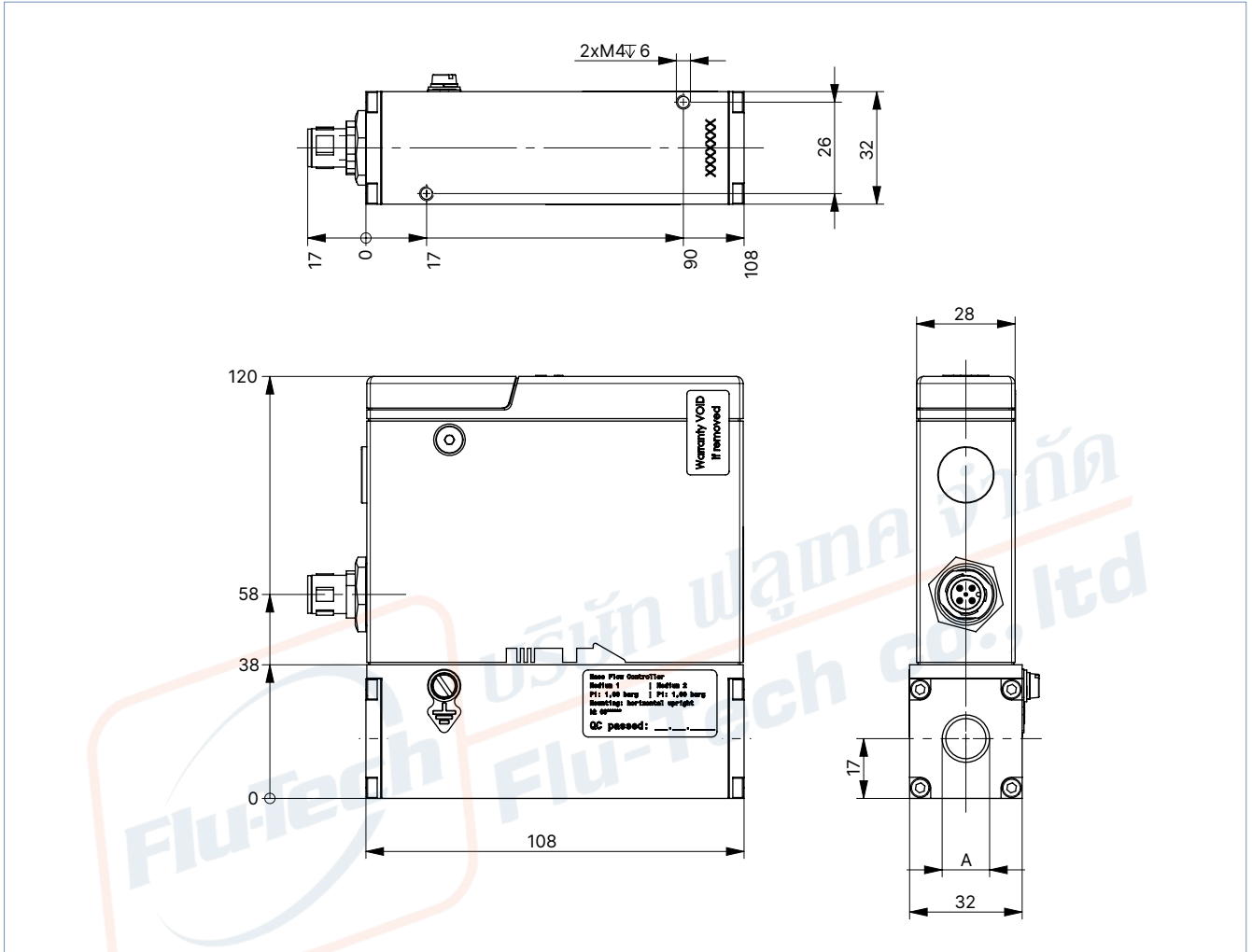

DTS 1000592376 EN Version: | Status: RL (released | freigegeben | valide) printed: 22.10.2025

5. Product connections

5.1. Communication

büS/CANopen

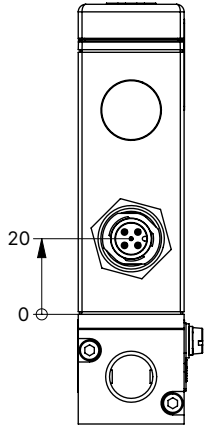

M12 plug, 5-pin (A-coded)		Pin	Assignment
		1	Shielding
		2	24 V
		3	DGND
		4	CAN_H
		5	CAN_L

PROFIBUS DPV1

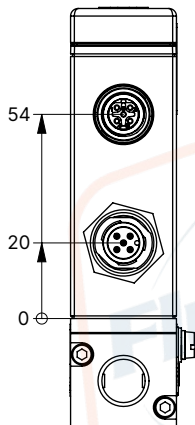

M12 socket, 5-pin (B-coded)		Pin	Assignment
		1	5 V
		2	RxD / TxD (line A)
		3	DGND
		4	RxD / TxD (line B)
		5	Not connected

M12 plug, 5-pin (A-coded)		Pin	Assignment
		1	Shielding
		2	24 V
		3	GND
		4	Not connected
		5	Not connected

6. Performance specifications

6.1. MFM pressure loss diagram

The diagram shows an example of the pressure loss curves with nitrogen flowing through. To determine the pressure loss of other gases, the corresponding air equivalent must first be calculated and the base block used for the other gas must be taken into account.

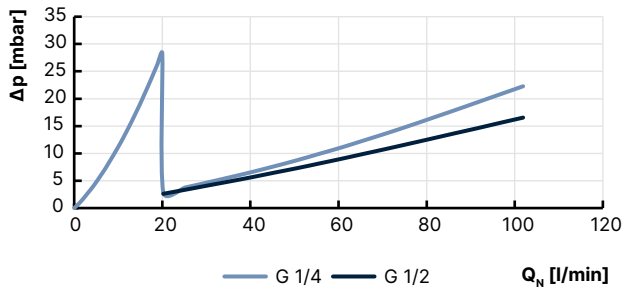

Formula for calculating the pressure loss in an MFM:

$$\Delta P_{\text{Gas}} = \Delta P_{\text{Air}} \sqrt{\frac{\rho_{\text{N Gas}}}{\rho_{\text{N Air}}}}$$

7. Product operation

7.1. Measurement principle

The measured values are recorded in a secondary channel. A laminar flow element in the main channel creates a slight pressure drop. A part of the gas flow is thereby directed into the secondary channel. This partial flow is proportional to the flow in the main channel (through the Laminar-Flow-Element). Two heating resistors are wound around the thin stainless steel tube. With the flow, heat is transported in flow direction. In this way, the heat transport can be used to infer a flow rate value. The sensor tube's wall acts as a thermal barrier and determines measurement dynamics. It is therefore slower than sensors with resistors directly placed in the gas flow.

These sensors can also be used to measure many aggressive gases, as all the wetted main parts are made of stainless steel. This sensor principle also allows conversion between different gases.

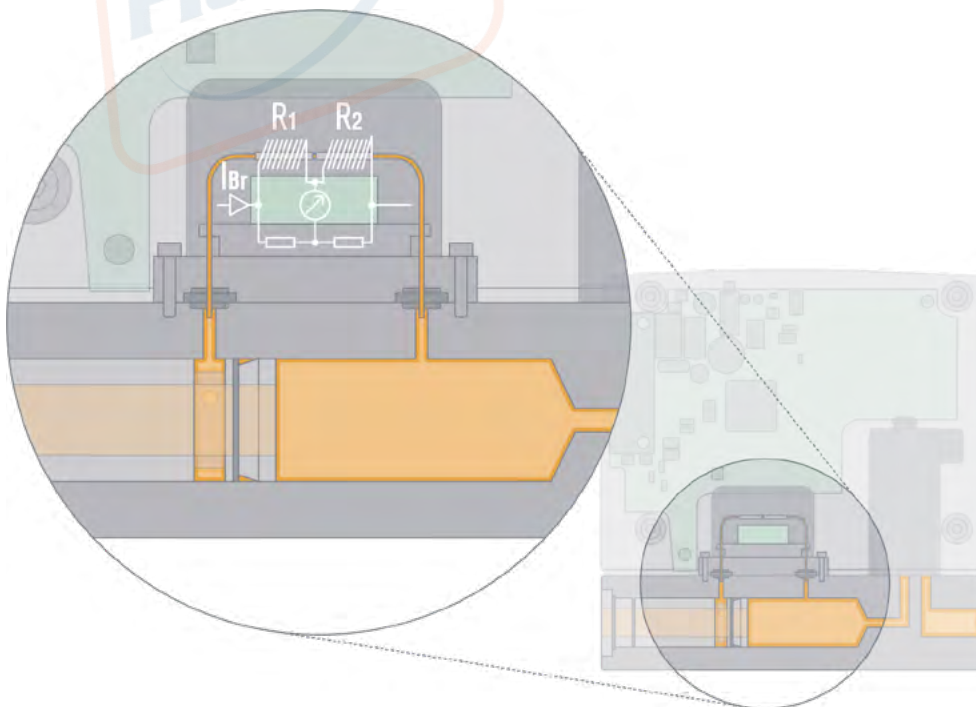

8. Product accessories

8.1. Bürkert Communicator software

Note:

The corresponding communication software can be downloaded from the website [Type 8920](#) ▶.

The Bürkert Communicator is the most important software component of the EDIP (Efficient Device Integration Platform). Various features of this universal tool simplify the configuration and parametrisation of devices equipped with a digital CANopen-based interface. With this tool, the user has a complete overview of cyclic process values as well as acyclic diagnostic data. The integrated graphical programming environment enables the creation of decentralised sub-system control functions. The connection to the PC is established with a USB-büS interface set. The adapter is available as an accessory (see “9.5. Ordering chart accessories” on page 19).

The Bürkert Communicator enables:

- Configuration, parametrisation and diagnosis of EDIP devices / networks
- Switching between defined gases
- Easy and comfortable mapping of cyclic values
- Graphic display, monitoring and storage of process values
- Firmware update of the connected EDIP devices
- Saving and restoring device configurations
- Zero-point adjustment in case of changed ambient conditions
- Guided re-calibration routine

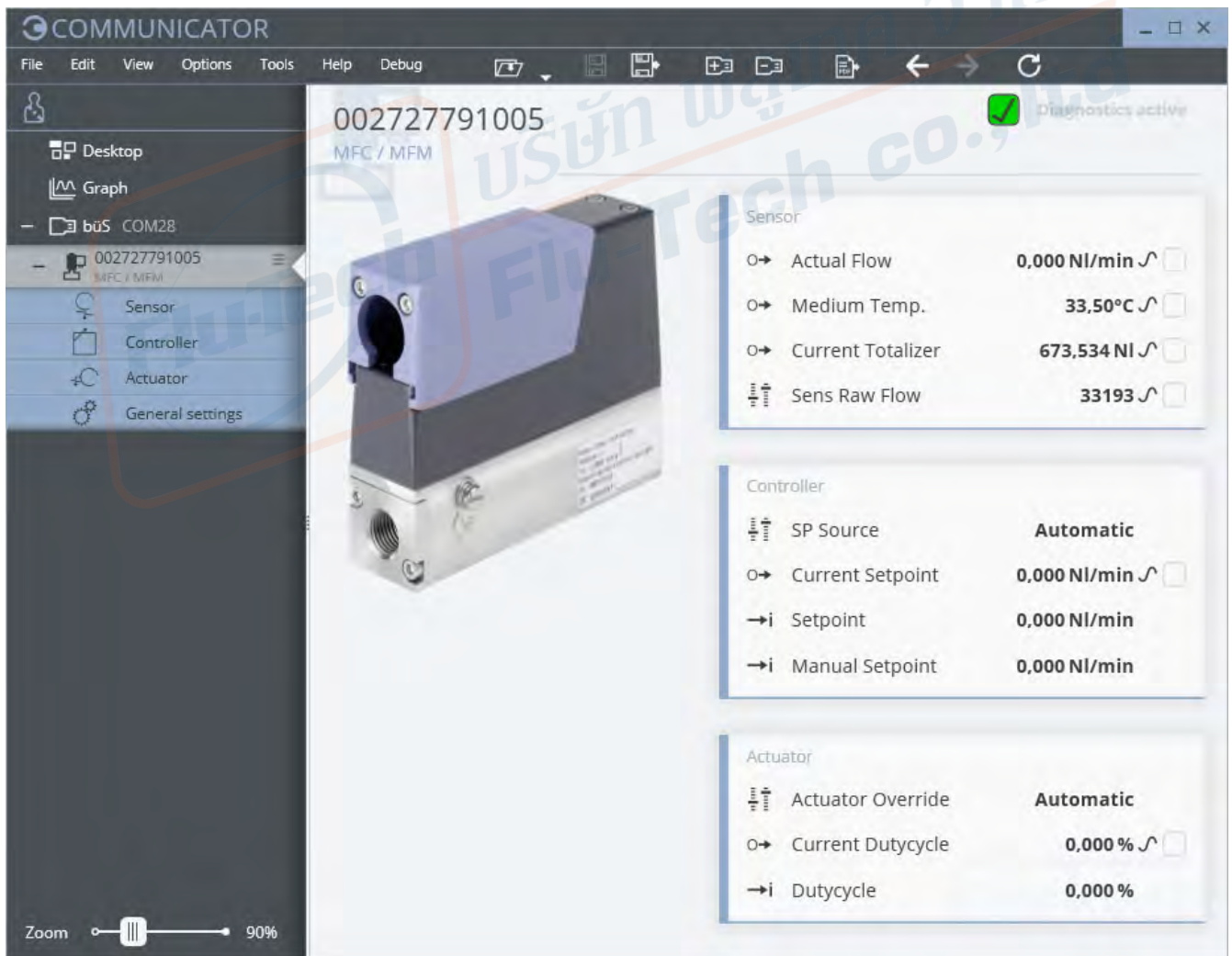

DTS 1000592376 EN Version: | Status: RL (released | freigegeben | valide) printed: 22.10.2025

8.2. Connecting Type 8744 with the Bürkert Communicator software

The Bürkert Communicator interface is based on CANopen. An appropriate bus termination is mandatory. With Type 8744 bus/CANopen, this terminating resistor must not be connected if the device is already integrated in a properly terminated bus network.

The device is connected via the 5-pin M12 plug (USB-bus interface set 1 contains the necessary accessories).

Note: no external power supply must be connected to the micro USB socket. The device must be provided with power as described in chapter "5. Product connections" on page 15.

8.3. Configuration management for easy device replacement

The 2 following device replacement options are available:

- If a device needs to be replaced, the memory card can be removed from the defective device and can be inserted into the new device. This transfers all data from the device to be replaced to the new device. The memory card is available as an accessory and must be ordered separately (see "9.5. Ordering chart accessories" on page 19).
- The device is exchanged via the configuration provider of the higher-level gateway control (ME43 or ME63). This requires a memory card in the gateway. The memory card is available as an accessory and must be ordered separately (see "9.5. Ordering chart accessories" on page 19).

In order to successfully exchange the device, it is necessary that both the new device and the device to be replaced have the same article number.

9. Ordering information

9.1. Bürkert eShop



Bürkert eShop – Easy ordering and quick delivery

You want to find your desired Bürkert product or spare part quickly and order directly? Our online shop is available for you 24/7. Sign up and enjoy all the benefits.

[Order online now](#)

9.2. Recommendation regarding product selection

Note:

Use the Product Enquiry Form (see "9.4. Bürkert Product Enquiry Form" on page 19) for information on the device layout and send it to us once completed.

For the proper choice of the actuator orifice within the MFC, you need to know not only the required maximum flow rate Q_N but also the pressure values directly upstream and downstream of the MFC (p_1, p_2) at Q_N . These are often not identical to the inlet and outlet pressure of the entire system, because there are usually additional flow resistances (pipework, additional shut-off valves, nozzles, etc.) both upstream and downstream of the MFC.

Use the Product Enquiry Form to indicate the pressures directly upstream and downstream of the MFC. If the pressure values are unknown or not accessible by measurement, an estimation is necessary, taking into account the approximate pressure drops via the flow resistances before and after the MFC at Q_N . The maximum expected inlet pressure $p_{1,max}$ must be specified to ensure the tight-closing function of the actuator in all operating states.

9.3. Bürkert product filter



Bürkert product filter – Get quickly to the right product

You want to select products comfortably based on your technical requirements? Use the Bürkert product filter and find suitable articles for your application quickly and easily.

[Try out our product filter](#)

9.4. Bürkert Product Enquiry Form

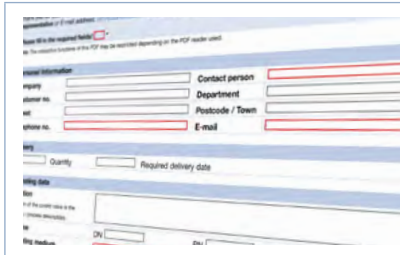

Bürkert Product Enquiry Form – Your enquiry quickly and compactly

Would you like to make a specific product enquiry based on your technical requirements? Use our Product Enquiry Form for this purpose. There you will find all the relevant information for your Bürkert contact. This will enable us to provide you with the best possible advice.

[Fill out the form now](#)

9.5. Ordering chart accessories

Description	Article number.
General accessories	
USB-büS interface set 1 (Type 8923) for connection to the Bürkert Communicator software: includes connection cable (M12 and micro USB), stick with integrated terminating resistor, power supply and software	772426
Power supply unit Phoenix Class2 (Type 1573), 85...240 V AC/24 V DC, 1.25 A, NEC Class 2 (UL 1310)	772438
Power supply unit for standard rail (Type 1573), 100...240 V AC/24 V DC, 1 A, NEC Class 2 (UL 1310)	772361
Power supply unit for standard rail (Type 1573), 100...240 V AC/24 V DC, 2 A, NEC Class 2 (UL 1310)	772362
Power supply unit for standard rail (Type 1573), 100...240 V AC/24 V DC, 4 A	772363
Memory card	On request
Device description files for software interfaces	Download from Type 8744
Bürkert Communicator software	Download from Type 8744
For Type 8744 büS/CANopen	
büS cable extension, M12, cable length: 0.1 m	772492
büS cable extension, M12, cable length: 0.2 m	772402
büS cable extension, M12, cable length: 0.5 m	772403
büS cable extension, M12, cable length: 1 m	772404
büS cable extension, M12, cable length: 1 m	772405
büS socket, M12, straight, A-coded ¹⁾	772416
büS plug, M12, straight, A-code ¹⁾	772417
büS socket, M12, angled, A-coded ¹⁾	772418
büS plug, M12, angled, A-coded ¹⁾	772419
büS Y-plug	772420
büS Y-plug for linking two separately supplied segments of a büS network	772421
büS plug, M12, terminating resistor 120 Ω	772424
büS socket, M12, terminating resistor 120 Ω	772425
LabVIEW device driver	On request
EDS file	Download from Type 8744

1.) For space reasons, M12 individual cable plugs may not be suitable for simultaneous use on the same side as a Y-distributor. Use a commercially available overmolded cable in this case.

DTS 1000592376 EN Version: | Status: RL (released | freigegeben | valide) printed: 22.10.2025