

AIRSWEEP® 1.5" THREADED PULSE VALVE

Best for corrosive, washdown, or regulated environments where longevity and compliance matter



IDEAL FOR EXTREME OR REGULATED ENVIRONMENTS • SLASHES CYCLE TIMES • DESIGNED FOR DURABILITY*

This globally patented pulse valve is specially designed for combining high flow, fast opening and closing to create a powerful pulse of compressed inert gas. Ideal for all industrial applications.

*Equal to 5 million cycles based on added lifespan from four free replacement springs

PRODUCT HIGHLIGHTS

FEATURES

- **Bodies:** Machined from solid stock, certified 316L Stainless Steel
- **Remote Pilot (RP):** High-temperature, or hazardous settings where safety, accessibility, and centralized control matters
- **Right Angle Porting:** Standard construction with Top Inlet and Side Outlet with Air Relief Exhaust Port on other side
- **Threaded connections:** Connect to airlines with threaded fittings National Pipe Taper (NPT) & British Standard Pipe Taper (BSPT)
- **Spring Return:** 316L Stainless Steel Compression Spring
- **Traceability:** All machined valve components available with material certifications
- **Warranty:** 7 years except 1 million cycles for springs

APPLICATIONS

Pulse valves are typically used for agricultural, personal care, pet care, utility processing, corrosive environments, mining, dust collectors, chemical and bag house applications.

OPERATION

Normally closed single acting plunger opens and closes with compressed air with the use of a solenoid valve. The compression spring allows the valve to be mounted in any position. **The valve requires filtered dry air, free from oil and particles.**

VALVE SPECIFICATIONS

CONSTRUCTION FEATURES

- **Body:** 316L Stainless Steel
- **Compression Spring:** 316L Stainless steel (1 million life cycle)
- **Plunger Assembly:** PEEK (Polyetheretherketone) and Viton (Fluoroelastomer)

The AirSweep PV-150-316 is fully machined from certified 316L Stainless Steel bar stock. The valve is equipped with NPT or BSPT threads and a threaded exhaust port with push-to-connect 3/8" (9.5mm) tube for simple installation.

AIRSWEEP PV-150-316 PRESSURE RATING

NOMINAL PORT SIZE		NUMBER OF PLUNGERS	FLOW COEFFICIENT*		WORKING PRESSURE PSI (Bar)	
1.5"	38.1mm	1	Cv	Kv	MIN	MAX
			51	44	20 (1.38)	110 (7.38)

*Flow coefficient (Cv) is the amount of water (in gallons per minute) at 60°F (15.56°C) that will flow through a fully open valve with a difference of 1 PSI (.07 Bar) between the inlet and the outlet.

Recommended on-time range: 50-500ms (Commonly used: .250ms)

Remote Pilot (RP) Requires: .52 Cv (0.45 Kv) Pilot Valve

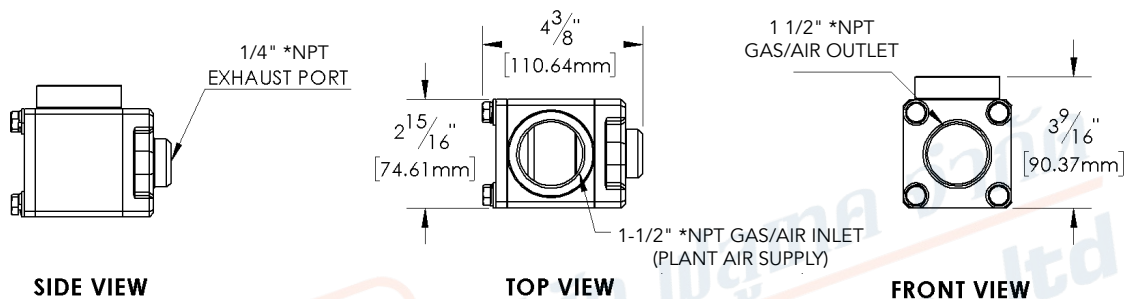

* National Pipe Taper

TECHNICAL SPECIFICATIONS

- **Pulse Valve:** Typically used for agricultural, personal care, pet care, utility processing, corrosive environments, mining, dust collectors, chemical and bag house applications
- **Valve Function:** Air Pulse
- **Valve Type:** Plunger
- **Connection Type:** Thread
- **Connection Style:** Pipe Thread (NPT & BSPT)
- **Pipe Size:** 1 1/2" (38.1mm)
- **Remote Pilot Connection:** 1/4" (6.35mm) NPT
- **Activation:** Remote Pilot .52 Cv (0.45 Kv) min
- **Flow Coefficient:** 51 Cv (44 Kv)
- **Max Pressure:** 110 PSI (7.58 Bar)
- **Minimum Pressure:** 20 PSI (1.38 Bar)
- **Temperature:** Remote Pilot (RP) Type 0-200°F (-17.77 - 93.33°C)
- **Body Materials:** 316L Stainless Steel
- **Seal Materials:** Viton
- **Plunger Material:** PEEK (Polyetheretherketone)
- **Spring Material:** 316L Stainless Steel (1 million life cycles)
- **Port Shape:** Right Angle
- **Made to last in Corrosive Environments:** 316L Stainless Steel
- **Specifications Met:** FDA Compliant 21 CFR 177.2415, FDA Compliant 21 CFR 177.2600
- **Weight:** Stainless Steel 5.1 lbs. (2.31 kg)
- **Torque Specifications:** Stainless steel type: 139 in-lbs. (1600 mm-kg)

AIRSWEEP PV-150-316 BILL OF MATERIALS

Item No.	Description	Material	Qty
1	PV Center Body	316L Stainless Steel	1
2	PV Outlet Body	316L Stainless Steel	1
3	PV Plunger Body	316L Stainless Steel	1
4	PV PEEK Plunger	Polyetheretherketone (PEEK)	1
5	PV Wear Ring	Polyetheretherketone (PEEK)	1
6	-224 O-Ring	Viton	1
7	PEEK Spring Seat	Polyetheretherketone (PEEK)	1
8	Compression Spring	316 Stainless Steel	1
9	-145 O-Ring	Viton	2
10	Flat Washer	316 Stainless Steel	4
11	Lock Washer	316 Stainless Steel	4
12	Hex Head Bolt	316 Stainless Steel	4

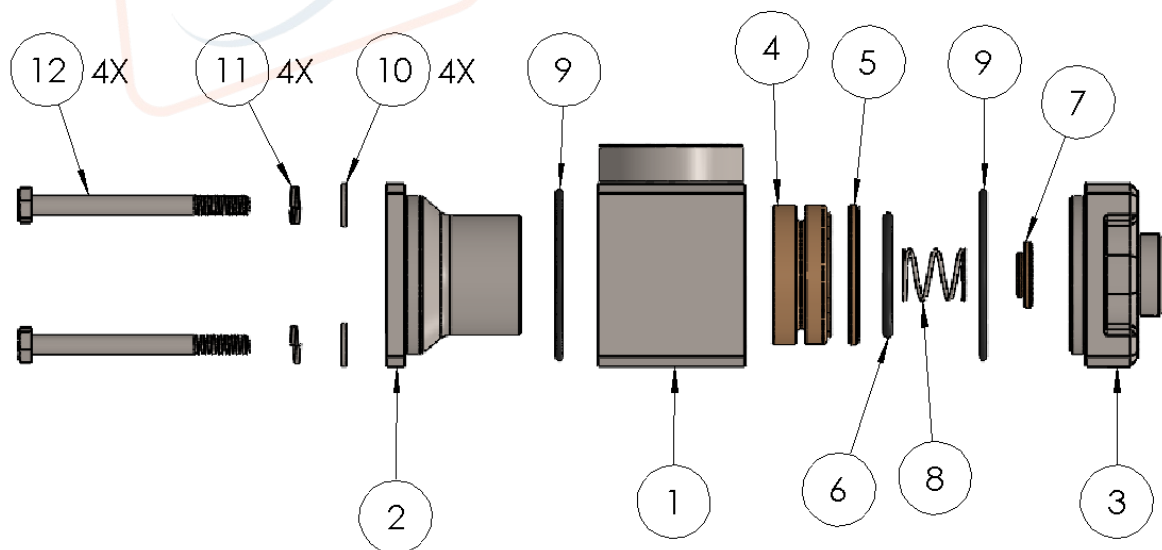

VALVE ACCESSORIES

REMOTE PILOT

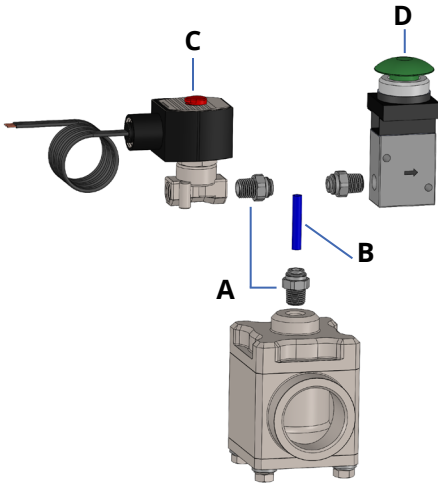

Tube Size	A Push-to-Connect	B Tubing and Max Length	C Pilot Valve	D Manual Air Valve
1/4" (6.35mm)	1/4" NPT x 1/4" Tube OD	1/4" OD x 11/64" ID 15' Max	.52 Cv (.45 Kv) Rated	.52 Cv (.45 Kv) Rated
3/8" (9.52mm)	1/4" NPT x 3/8" Tube OD	3/8" OD x 9/32" ID 30' Max	.52 Cv (.45 Kv) Rated	.52 Cv (.45 Kv) Rated

Note: Lengths of tubing between Pulse Valve and Pilot Valve, at MAX length, ON-time needs to be increased by 100 ms.

SYSTEM CONNECTIONS

