



HVD 450

Safe and wear-free discharging of High Voltage DC links

TUV NORD
Zertifizierung

Application

As industries shift to higher voltages of up to 1500V in DC links, efficient energy storage and discharge systems are crucial. Traditionally, mechanical contactors were used but faced wear and tear when switched under load. The HVD 450 eliminates this issue by seamlessly switching discharge circuits without wear down, ensuring long-lasting performance. It integrates precise current and voltage monitoring for real-time surveillance of the discharge process. Control is simple and efficient with a standard 5-24V signal from a PLC. The device provides comprehensive feedback on the discharge process, including potential errors or hazards. Experience the future of discharge technology with the HVD 450.

Features

- SiC-based solid state contactor
- Wear-free switching of high voltage DC links
- Fast discharge times due to high current (8A per device, multiple devices in parallel are possible to multiply the current)
- Integrated current and voltage monitoring
- Robust and intelligent replacement for discharging contactors
- Status outputs and signalling of potential hazards

Manual HVD 450

Doc-Nr.: 731
Revision: 2.5
Issue date: 10/2023

Manufacturer:

Mütec Instruments GmbH
Bei den Kämpfen 26
21220 Seevetal
Deutschland

Licence-, trademark and copyright notes

Copyright © Mütec Instruments GmbH

All rights reserved

This document is copyright protected. It supports the user in making reliable and efficient use of the unit. Transmission and duplication of this document as well as utilization and disclosure of its content are prohibited unless expressly permitted. Any breach or infringement shall result in liability for damages. The software described in this document is licensed and may only be used and copied in accordance with the terms of the licence.

All rights reserved.

Disclaimer

We have checked the content of the printed document for compliance with the described hardware and software. Nevertheless, deviations cannot be excluded and consequently we cannot assume any guarantee for complete accordance. The data in this printed document are checked regularly. Corrections and additions are made in the following version in each case. We would be grateful for any suggestions for improvement.

Technical modifications reserved

Content

1	Safety instructions and installation	4
2	Safety Instruction Classification	5
3	General Instructions	7
4	Technical Data	11
4.1	Load Output	11
4.2	DC Link Input	11
4.3	Discharge Status Output.....	11
4.4	Error Status Output.....	11
4.5	Start Signal Input	11
4.6	Supply	11
4.7	LEDs	11
4.8	General Data	12
4.9	Standards	12
4.10	Installation.....	13
4.11	Housing Dimensions.....	14
4.12	Block diagram	14
4.13	Nameplate	15
5	Connection to the DC Link	15
5.1	Curves and functions of the discharge process	15
5.2	Example calculation for the discharge parameters	16
5.3	Setting the time constant	17
6	Increase Discharge Currents by Parallelization	17
7	Functional description of the HVD 450	18
7.1	Measurement.....	18
7.2	Measurement accuracy	18
7.3	Discharge Process.....	18
7.4	Possible Error Causes	20
7.5	State Overview	21
7.6	State Diagram.....	22

1 Safety instructions and installation



HAZARD: High Voltage / Danger to Life

The device is designed for secondary voltages of up to 2000 V. and may only be used in safe operating environments. The specified safety conditions and safety guidelines (including national safety guidelines, accident prevention regulations) must be observed for installation and operation. Safety guidelines (including national safety guidelines), accident prevention regulations and general technical regulations must be observed. Please observe the safety instructions on the following pages.

Note: High voltage may only be connected to 3-pole terminals

T-21/22(+) and **T25/26(-)** for Discharge Circuit

T-17/18(+) and **T25/26(-)** for DC Link



Note: Installation, operation and maintenance may only be carried out by qualified specialized personnel.

When installing and operating the device, the applicable safety guidelines (including the national safety guidelines), accident prevention regulations and general technical regulations must be observed.



Note: The circuits in the device must not be accessed.

Do not repair the device yourself but replace it with an equivalent device. Repairs may only be carried out by the manufacturer.



Note: The device is suitable for protection class IP20 if:

- It is installed outside of potentially explosive areas
- The environment is clean and dry



Two-pole disconnecting device:

In accordance with the LVD standard, a two-pole disconnecting device must be provided between the device and the auxiliary power. It must be clearly marked and easily accessible.

Install the device in a suitable housing with a suitable degree of protection according to IEC 60529 to protect against mechanical and electrical damage.

The safety-relevant data can be found in the operating instructions or in other certificates (if necessary).

2 Safety Instruction Classification

This manual contains instructions that you have to observe for your personal safety as well as to avoid material damage. These instructions are highlighted using a triangular warning sign and shown as follows, depending on the degree of risk.



HAZARD

means that death or severe physical injury will occur if the appropriate precautionary measures are not taken.



WARNING

means that death or severe physical injury may occur if the appropriate precautionary measures are not taken.



CAUTION

with a triangular warning sign means that minor physical injury may occur if the appropriate precautionary measures are not taken.

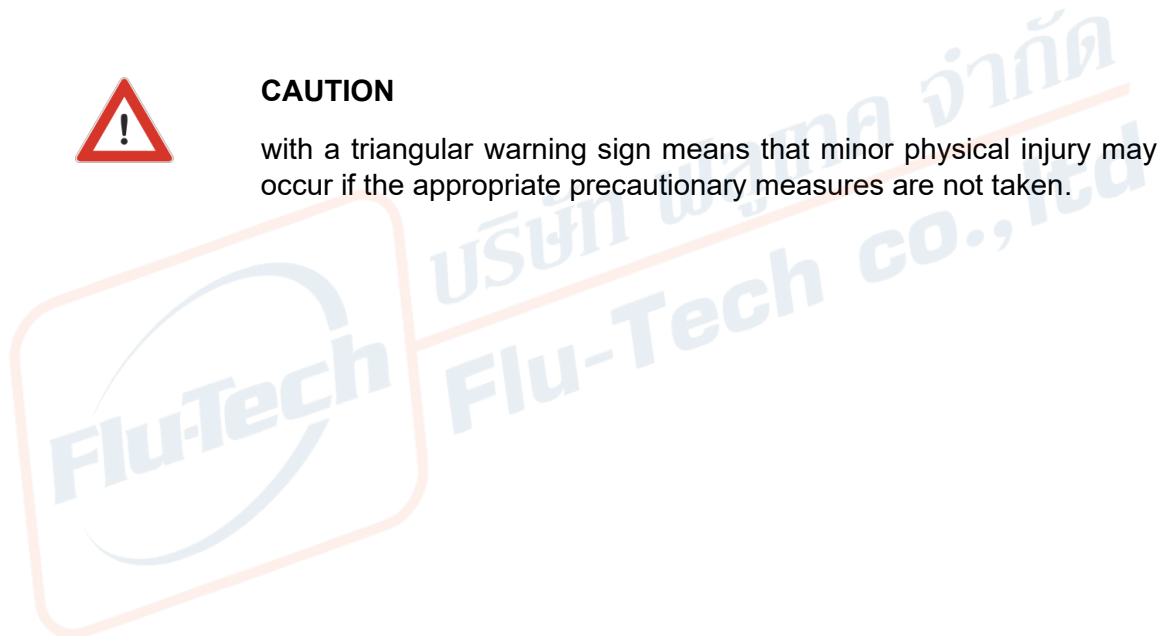

CAUTION

without a triangular warning sign means that material damage may occur if the appropriate precautionary measures are not taken.

**ATTENTION**

means that an undesired result or state may ensue if the corresponding instruction is not followed.

**NOTE**

denotes important information about the product, handling of the product or the respective part of the documentation, is aimed at drawing special attention to the latter and should be complied with.

In addition to the instructions in this manual, the generally applicable safety and accident prevention regulations must be observed. If the information contained in this document should not be sufficient in any specific case, you can obtain more detailed information from our telephone service. Please read this manual carefully prior to installation and commissioning.



บริษัท ฟลูเทค จำกัด
Flu-Tech Co., Ltd.

3 General Instructions

This device left the plant in flawless condition in terms of its safety features. To preserve this condition and ensure safe operation of the device, the user has to observe the instructions and warning notes indicated in this operating manual.

For the sake of clarity the manual does not contain complete detailed information on all product types and can therefore not take into account every conceivable case with respect to installation, operation and maintenance.

Should you wish further information or should special problems arise that are not treated in sufficient detail in the manual, you can obtain the necessary information by telephone.

Moreover, we point out that the content of the manual shall not constitute part of or amend a previous or existing contract, agreement or legal relationship. All obligations of Mütec Instruments GmbH shall result from the respective contract of purchase, which also contains the complete and solely valid warranty terms. These contractual warranty terms shall neither be extended nor limited by the information contained in the manual.

The content reflects the technical state of the art regarding printing. It is subject to technical modifications in the course of further development.

WARNING

Flawless and safe operation of this device requires proper transport, proper storage, installation and assembly as well as careful operation and maintenance. The device may only be used for the purposes specified in this operating manual.

DISCLAIMER

All modifications to the device fall within the responsibility of the user unless expressly specified otherwise in the operating manual.

VALIDITY

The data sheet is only valid for the HVD 450 described and the hardware / firmware version specified in the technical data

QUALIFIED PERSONNEL

Qualified personnel are persons who, due to their training, experience and instruction as well as their knowledge of relevant standards, regulations, accident prevention regulations and operating conditions, have been authorized by the person responsible for the safety of the system to carry out the necessary planning and activities and thereby recognize and recognize possible dangers can avoid.

REQUIREMENTS

The qualified personnel must have knowledge of the following topics:

- Handling and knowledge of and about security products
- Applicable EMC regulations
- Applicable regulations for work safety and accident prevention
- Installation or assembly of the safety product
- Commissioning, monitoring and maintenance of the security product
- Knowledge of devices / systems in accordance with the standards of safety technology for electrical circuits
- Training or instruction in accordance with the standards of safety technology in the care and use of appropriate safety equipment



บริษัท ฟลูเทค จำกัด
Flu-Tech co., ltd

SAFETY INSTRUCTIONS

The safety regulations of electrical engineering and the trade association must be observed and adhered to. Failure to observe the safety regulations can result in death, severe physical injury, or extensive property damage.

DIRECT / INDIRECT TOUCHING

Protection against direct and indirect contact in accordance with VDE 0100 Part 410 must be guaranteed for all components connected to the system. In the event of an error, there must be no dangerous carry-over of voltage (single-fault security).

ASSEMBLY, COMMISSIONING, MODIFICATION

Assembly, commissioning, modification and retrofitting may only be carried out by qualified personnel. Before starting work, the device must be disconnected from the power supply. The wiring must be carried out and checked according to the intended use. Reliable function is only guaranteed if the device is installed in a dust- and moisture-proof switch cabinet or a housing (min. IP54). Separate cable routing for the high voltage on the one hand and all other circuits on the other is recommended.

SWAPPING AND REVERSING THE CONNECTIONS

Take measures to prevent polarity reversal or manipulation of the connections.

DEVICE IN OPERATION

During operation, the input section of the HVD 450 is under dangerously high voltage. Do not remove any protective cover (blind cap between the terminal blocks) or cables on the terminals during operation. Suitable / effective protective circuits must be provided for inductive loads on the relay circuits. The protective circuit with suppressor diodes or varistors must always be in parallel with the load.

BROKEN DEVICE

The device may be damaged after an error. Correct and safe operation is then no longer guaranteed and the device should therefore be replaced. Only the manufacturer or a person authorized by the manufacturer may open the housing and repair the device. Otherwise any guarantee will be lost.

DECOMMISSIONING AND DISPOSAL

The device must be disposed of in accordance with environmental regulations. It must be ensured that a defective device cannot be used again.

ELECTROSTATIC DISCHARGE

Potentially electrostatic components may be destroyed by voltage that is far below the limits of human perception. Such voltage occurs even when you touch a component or electrical connections of a component and are not electrostatically discharged. The damage that occurs to a component because of overvoltage usually cannot be detected immediately and does not become noticeable until after a longer operating period.

The device contains components that can be damaged or destroyed by electrostatic discharge. When handling the device, observe the necessary safety measures against electrostatic discharge (ESD) in accordance with EN 61340-5-1 and EN 61340-5-2.

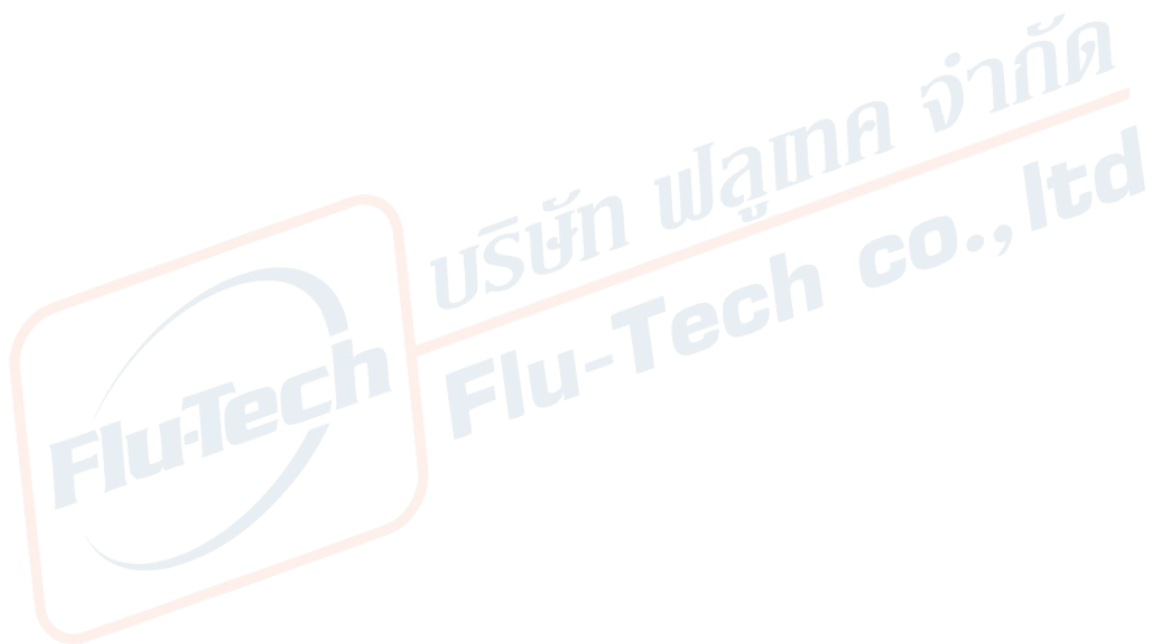

4 Technical Data

4.1 Load Output

T-21/22(+) and T-25/26(-)		
Voltage U_c :	$\leq 1500 \text{ V}$	Max. DC link voltage
Current I_c :	$\leq 8 \text{ A}$	Max. discharge current
Current I_G :	$\geq 9.6 \text{ A}$	Limit value current alarm
Residual voltage U :	$< 10 \text{ V}$	
Discharge time constant τ :	$100 \text{ ms} \dots 10 \text{ s}$	

4.2 DC Link Input

T-17/18(+) and T-25/26(-)	
Measurement range:	$0 \dots 1500 \text{ VDC}$

4.3 Discharge Status Output

T-5(+) and T-6(-)		
Discharge Signal:	ON = LOW ($\sim 3\text{V}$)	Open Collector Output ($5 \dots 30 \text{ VDC}$, $I \leq 50 \text{ mA}$)

4.4 Error Status Output

T-7(+) and T-8(-)		
Error Signal:	ON = LOW ($\sim 3\text{V}$)	Open Collector Output ($5 \dots 30 \text{ VDC}$, $I \leq 50 \text{ mA}$)

4.5 Start Signal Input

T-9(+) and T-10(-)		
Start Signal:	$5 \dots 30 \text{ VDC}$	High Level

4.6 Power Supply

T-3(+) and T-4(-)	
Supply voltage:	24 VDC ($18 \dots 30 \text{ VDC}$)
Power consumption:	Max. 1W

T-1/2	
PE / Grounding:	additionally by the ME-MAX board contact after placing on the grounded top-hat rail

4.7 LEDs

Power:	Green LED	Supply on
Error:	Red LED	Failure indication
Discharge:	Yellow LED	Discharging

4.8 General Data

Environmental Conditions

Operation:	-10 °C ... +60 °C
Storage/Transport:	-20 °C ... +80 °C
Perm. Rel. Humidity (during operation):	10 % ... 95 % r. H. no. Cond.
Max. operating altitude::	≤ 2000m above mean sea level

Galvanic Isolation

3 port isolation:	Input / output / supply
Input / Output:	4,3 kV AC test voltage
Input / Supply:	4,3 kV AC test voltage
Overvoltage category:	CAT II: 1500 V AC/DC
Pollution level:	2 according to IEC 61010-1

Electrical Connection

T-1 ... T-12 (4-pole):	Screwed connector/black / 5,0 mm ²
T-17 ... T-27 (3-pole):	Screwed connector / grey / 7,5 mm ²
Wire:	0,2 mm ² / 2,5 mm ² (min/max)
Braid:	0,2 mm ² / 2,5 mm ² (min/max)
Conductor cross-section:	AWG/kcmil = 14/24 (min/max)
Stripping length:	7 mm
Connection:	Pluggable screw
Tightening torque:	0,5 ... 0,6 Nm

PCB

Material:	FR4
CTI value:	≥175 V

Housing

Material:	Polyamide – light grey
Protection class:	IP20
Flammability class/UL 94:	V0
Weight:	250 g
Form of construction:	terminal box for mounting rails
Housing mounting type:	35 mm DIN-rail
Assembly/installation:	arbitrary

4.9 Standards

EMC	Product Family Standard EN 61326-1 Emission: Class A Immunity: Industry area
LVD	Low Voltage Directive IEC 61010-1

4.10 Installation

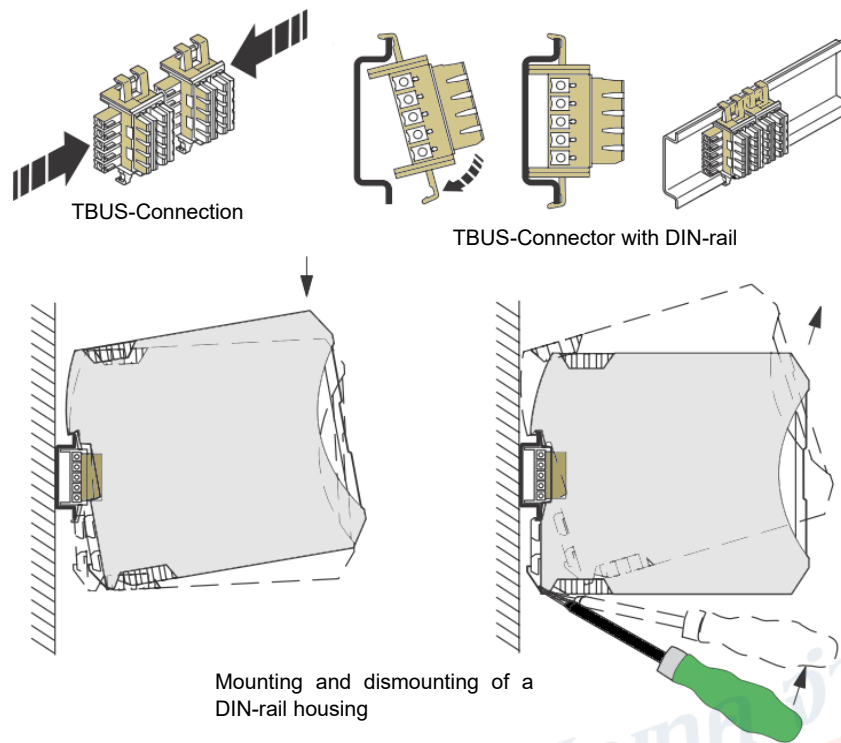

Figure 1 - DIN-rail housing and mounting

Important note:

The device may only be attached to or removed from the TBUS-Connection when power is switched off!

Attach the housing to a 35 mm DIN-rail according to EN 60715. For installation, mount the snap-lock to the DIN-rail and lock it. For dismounting, use a screw-driver to unlock the snap-lock.

4.11 Housing Dimensions

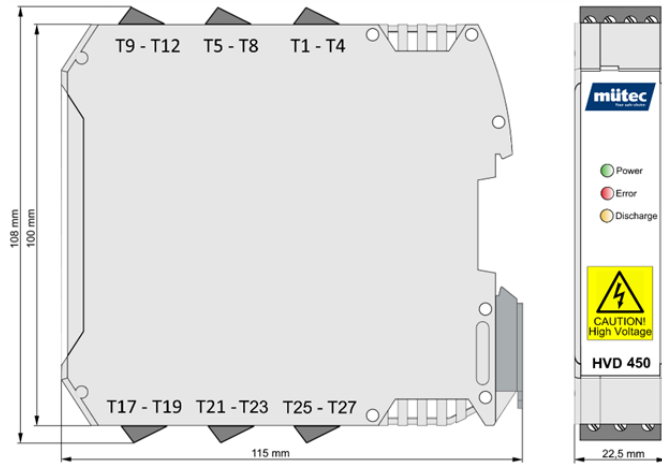

Figure 2: Housing Dimensions

4.12 Block diagram

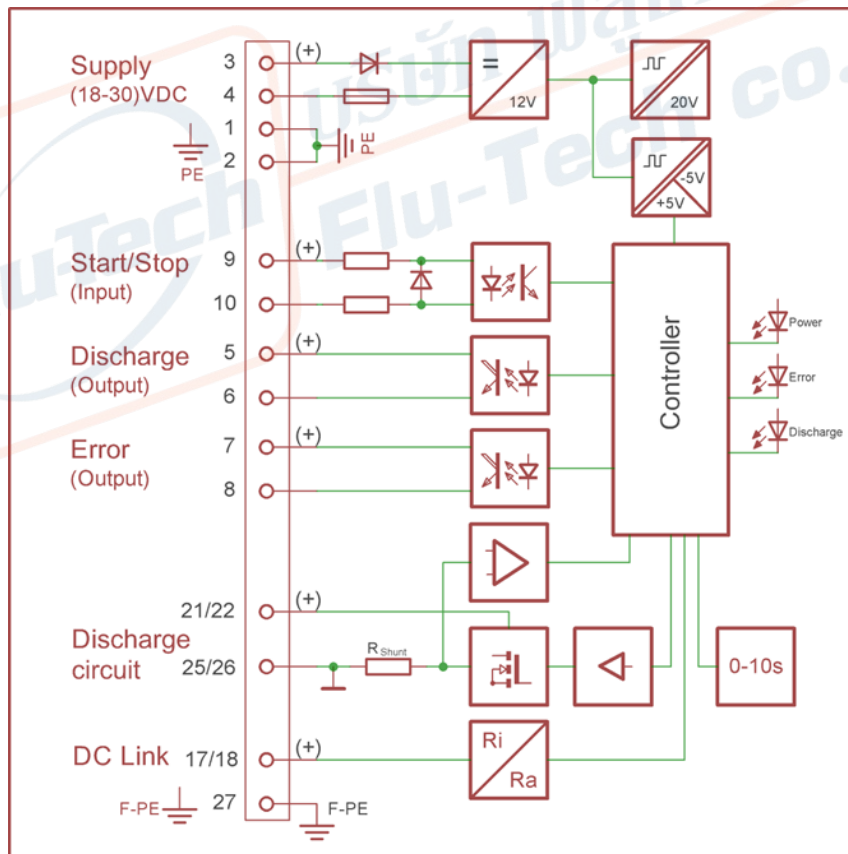

Figure 3: Block diagram and galvanic isolations

4.13 Nameplate

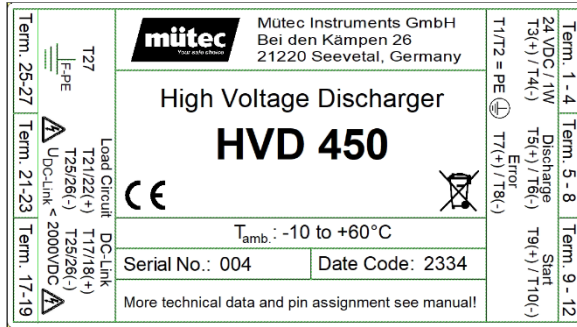

Figure 4: Nameplate

5 Connection to the DC Link

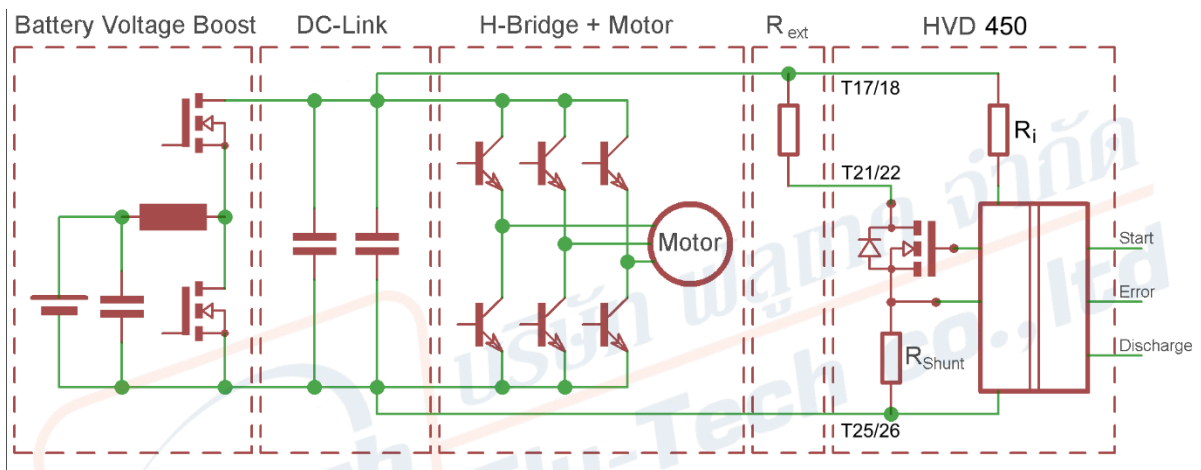
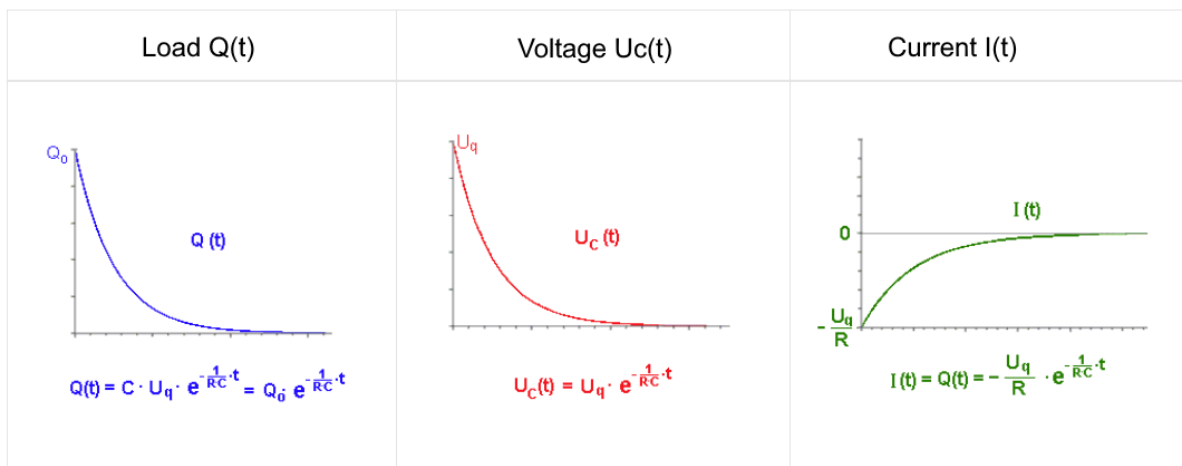

Figure 5: connection of HVD 450 to DC Links

5.1 Curves and functions of the discharge process



5.2 Example calculation for the discharge parameters

R_{ext} = current limiting resistor

U_C = Capacitor voltage (e.g. 1600V)

I_C = max. current (≤ 8 A)

C = DC Link capacity (e.g. 1000 μF)

External resistor $R_{\text{ext}} = U_C / I_C$

$$R_{\text{ext}} = 1600 \text{ V} / 8 \text{ A} = 200 \text{ } \Omega$$

Time constant $\tau = C \times R_{\text{ext}}$

$$\tau = 1000 \text{ } \mu\text{F} \times 200 \text{ } \Omega = 200 \text{ ms}$$

Energy stored in the capacitor $E_C = \frac{1}{2} C \times (U_C)^2$

$$E_C = \frac{1}{2} 1000 \text{ } \mu\text{F} \times (1600 \text{ V})^2 = 1280 \text{ Ws}$$

Power converted in the resistor $P_{R_{\text{ext}}} = E_C / 5\tau$

$$P_{R_{\text{ext}}} = 1280 \text{ Ws} / 1,0 \text{ s} = 1280 \text{ W}$$

The power converted in the resistor at the beginning of the discharge is:

$$P_{\text{Peak}} = 1600 \text{ V} \times 8 \text{ A} = 12,8 \text{ kW}$$

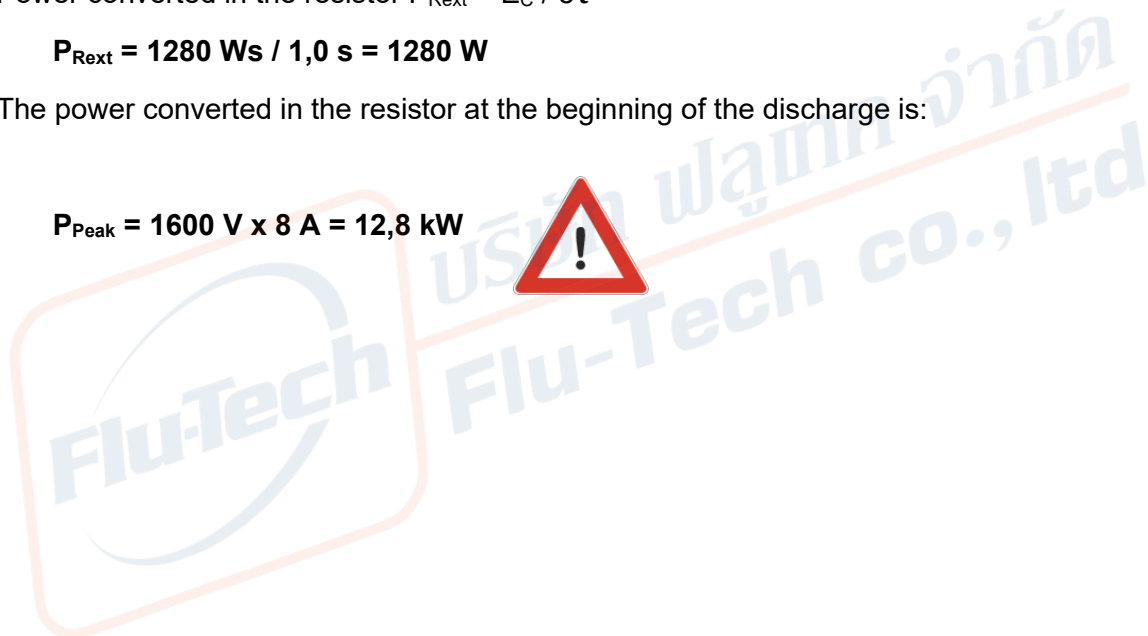

5.3 Setting the time constant

For monitoring the discharge process of the capacitance from the DC link, the time constant "T" must be set in the HVD 450. This time constant "T" must always be greater than the time constant $R_{ext} \times C$. Generally, this setting must be defined before the shipment, given that it is only available for the manufacturer and is set prior to delivery.

The following time constants are available with the 10-step coding switch:

Position	Time constant
0	100 ms
1	200 ms
2	500 ms
3	1 s
4	2 s
5	5s
6 - 9	10s

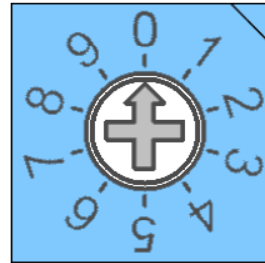

Figure 6: coding switch positions

The following is an example of the switch position to be selected:

$$\tau = C \times R_{ext} = 470 \mu\text{F} \times 330 \Omega = 155 \text{ ms} \quad C = 470 \mu\text{F}, R_{ext} = 330 \Omega$$

The result of 155 ms means that at least coding switch position 1 must be selected. It is recommended to use the higher time constant when in doubt.

6 Increase Discharge Currents by Parallelization

A single HVD 450 has a rated maximum current of 8 A. To increase the overall discharge current, it is possible to use multiple HVDs in parallel using external load resistor of the same size for each HVD. The start signal has to be applied to all HVDs simultaneously.



CAUTION

The external load resistors must be identical in size to avoid overloading.

7 Functional description of the HVD 450

7.1 Measurement

A measurement interval of 100µs is used to measure the discharge voltage. The measurements are averaged within a time window of 1ms. This means that every millisecond a new measured value is available.

7.2 Measurement accuracy

With a reference voltage of 5V and a voltage divider of 10M to 23k5 corresponds to 1 bit of the 12-bit ADC corresponds to a value of 520mV.

Error assumption: 1% of the measured value + 5 digit base error (corresponds to 2.6V);

The measurement error U_{err} is thus calculated as follows:

$$U_{Err} = (U_{in}) = U_{in} \times 0.01 + 2.6 \text{ V} \quad [1]$$

U_{in} = input voltage [V]

7.3 Discharge Process

Generally, the device calculates the expected discharge characteristics by measuring the initial voltage U_0 and considering the selected time constant, which is based on the used external load resistance and the capacity to be discharged. For each time step $t[n] - t[n-1]$, 20% of the voltage $U[N]$ must be discharged. Larger time constants have smaller time steps and are potentially more susceptible to interferences. After reaching a voltage of less than 10 V, the device waits for 5τ to cope with residual voltage discharge.

NOTE



After discharging, the device is on cooldown for 10τ before returning to its initial state. This is necessary to avoid overheating of the internal components. Moreover, it aims at **protecting the system from unintended restart**.

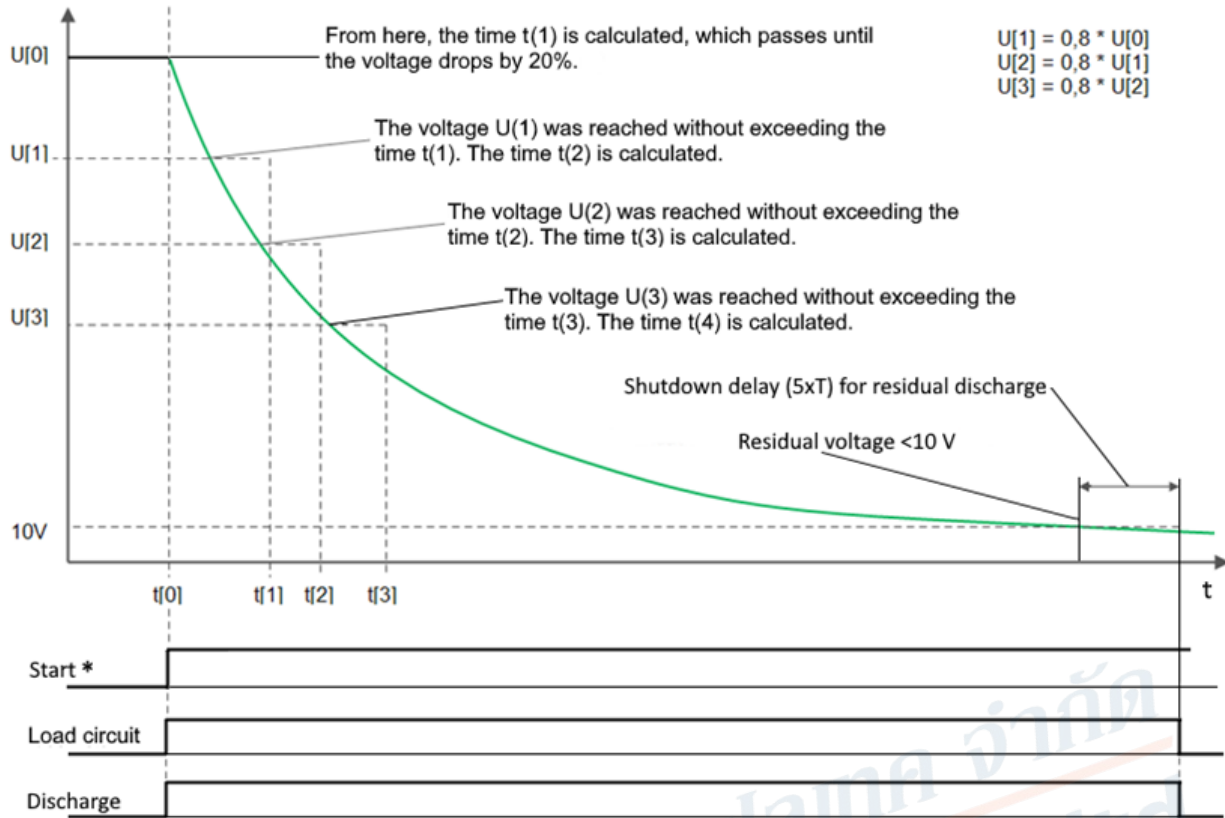

Figure 7: DC Link voltage function

The maximum time constant ($\tau = R \times C$) for discharge shall be 100ms.

Calculation of the discharge time:

The time required to achieve a voltage drop of 20% at 100ms is calculated. The calculation also takes into account the measurement error.

$$\Delta t = \tau * \ln\left(\frac{U_0 + U_{Err}(U_0)}{U_1 - U_{Err}(U_1)}\right) \quad [2]$$

- τ = assumed maximum time constant for the discharge current (100ms)
- U_0 = Initial voltage
- $U_{Err}(U_0)$ = Measurement error for voltage U_0 calculated according to [1].
- U_1 = Target voltage ($0.8 * U_0$)
- $U_{Err}(U_1)$ = Measurement error for voltage U_1 calculated according to [1].

7.4 Possible Error Causes

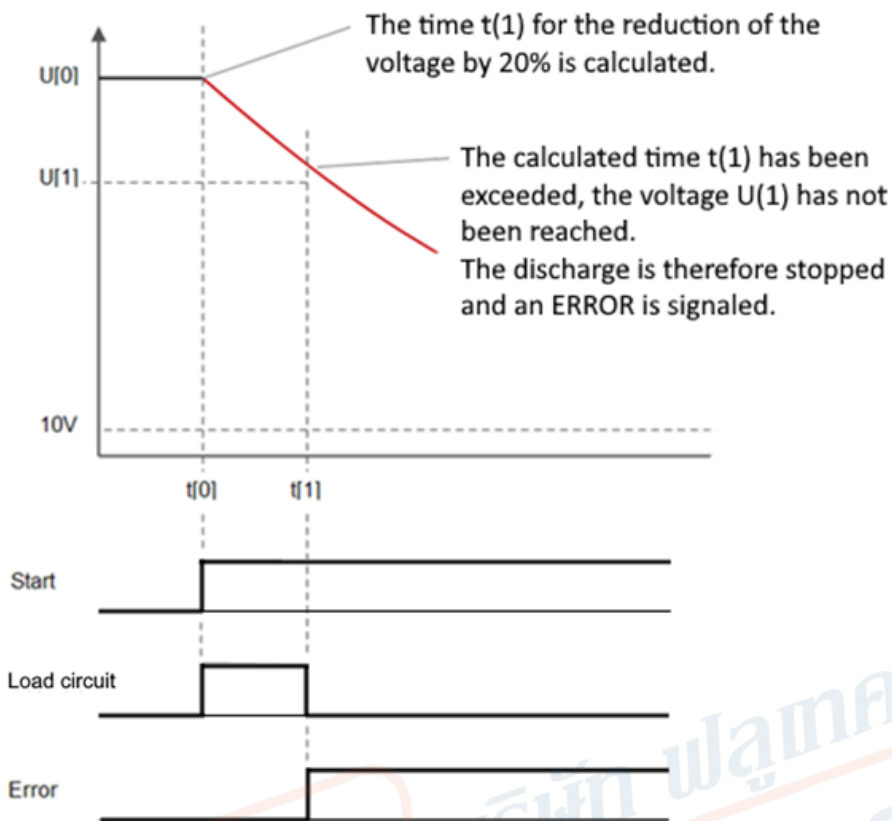

Figure 8: Failed discharge due to exceeding the assumed time constant

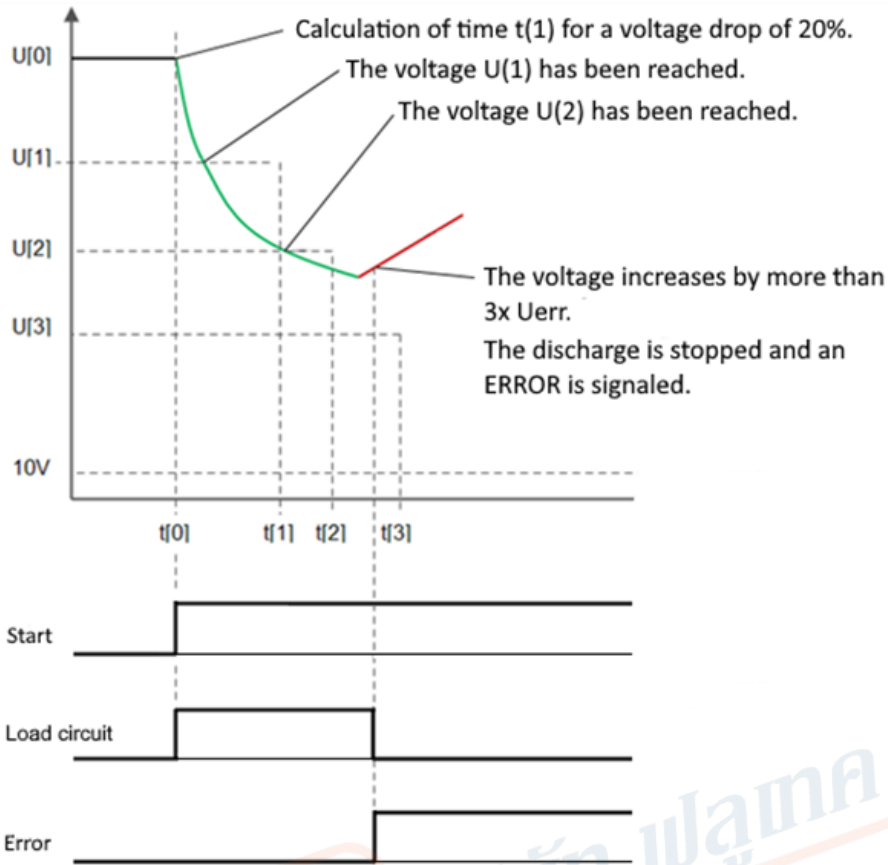

Figure 9: Failed discharge due to increasing voltage (e.g. re-activation of DC link supply)

7.5 State Overview

Table 1: Status overview

#	Power	Error	Discharge	Status	Note
0	OFF	OFF	OFF	Switched off	No supply connected
1	ON	OFF	OFF	Ready	Device ready to discharge
2	ON	OFF	ON	Discharging	Discharge in progress
3	ON	ON	ON	Cooldown	Protective measure against overheating or currently booting
4	ON	ON	OFF	Error	Potentially dangerous failure, not able to safely discharge. Check wires and components and restart the device to reset

7.6 State Diagram

To clarify the behaviour of the device and the resulting states defined in chapter 7.5, the following state diagram shows the operation modes of the devices.

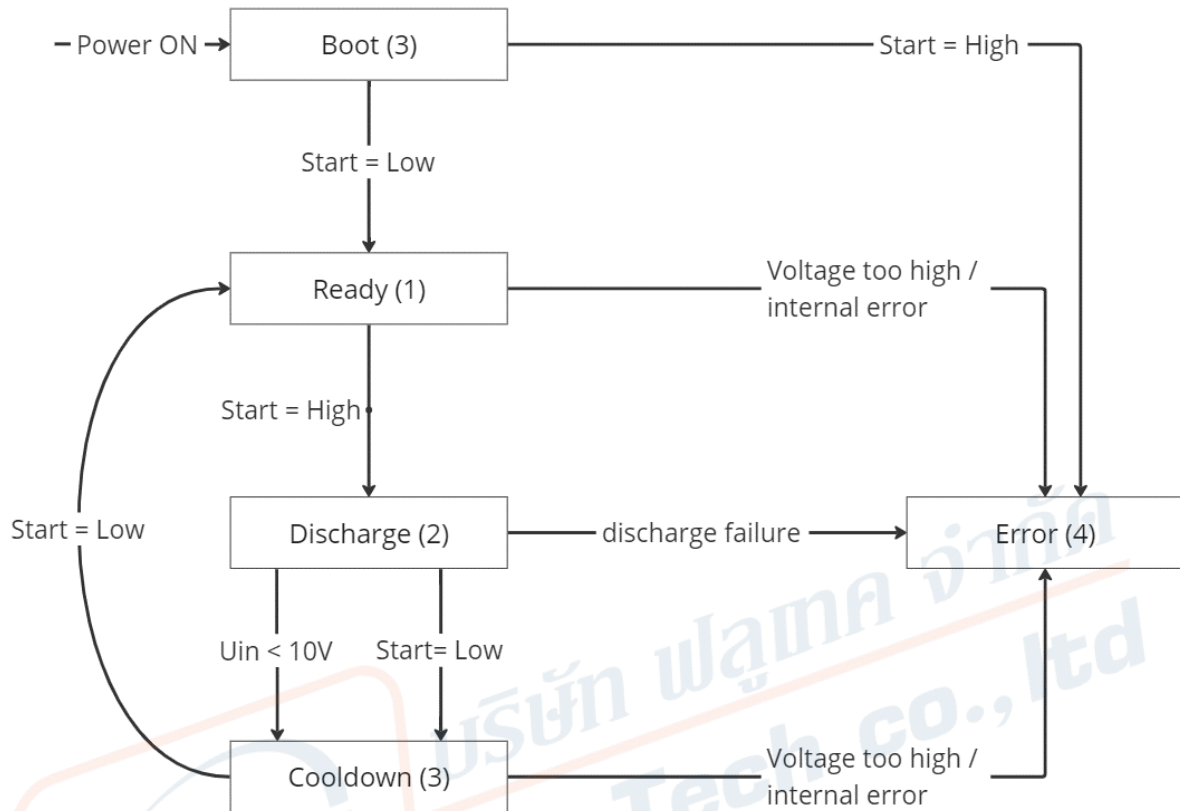

After the boot procedure, the device switches to the ready state (applying the Start signal before powering up the device leads to an error).

Exemplary, depending on the current state, different reasons can cause the device to signal an error.

Voltage too high / internal error

- DC Link voltage monitoring: If 2100 V are exceeded for several milliseconds, the device signals an error
- Monitoring of device-internal voltages: failure also leads to error-state

Discharge failure

- Current is too high (might overload the load resistance)
- Capacity is too high for the set time constant
- DC Link voltage rises during discharge (e.g. re-application of the supply voltage)

Start = High

- If the start signal is applied when the supply voltage is connected, the device will signal an error. This is due to the protection against unintended restart.

**HAZARD**

To reset the device from the error state, a power cycle is required. Please do not reset the device without checking the potential reasons for the error to occur.

After discharging, the device automatically enters a cooldown state. If the Start signal is set to low, the devices is ready for operation again.

