

FlowSwitch FS 510

Continuous flow monitoring
for bulk materials



NEW: ATEX Option



Application

The FlowSwitch FS 510 is monitoring the conveying stream of solids.

It is a robust microwave-based flow / no-flow switch and detects failures and problems during the transport or feeding of powders, dust, pellets or granules. This helps to prevent serious difficulties that can occur due to clogged piping, material loss, or other technical problems with the conveying system. The compact device can be used wherever monitoring of bulk solids movement is required.

Scope of use

Animal feed industry
Building materials
Cement industry
Production of ceramics
Chemical industry
Coating processes
Detergent industry
Food industry
Foundries
Glass production
Lime plants
Metal production

Minerals
Pharmaceuticals
Pigment production
Plastic manufacturing
Power plants
Recycling industry
Rubber goods
Synthetic materials
Textiles
Wood & Pellets
etc.

Main Benefits

- Reliable, contactless microwave measurement
- Works within several meters distance
- Does not interfere with the material
- Very sensitive and flexible with adjustable amplification, filter, hysteresis, delay, min/max
- Compact and easy to install and retrofit
- Wear- and maintenance-free
- Robust stainless steel design
- 100% safe operation with active self-monitoring
- ATEX protection (optional up to zone 20/21)

Function

The FlowSwitch FS 510 is based on modern microwave technology. If material passes the sensor, the emitted microwaves are reflected. This is converted into a switching process.

The sensor can be installed within pipes, on conveying belts, fall plates, chutes or at similar transport facilities. It allows safe identification of flow / no-flow, inadequate or missing material, plugs, blockage or standstill – from several meters distance. It does not impact the bulk material and is wear- and maintenance-free.

All parameters, like sensitivity, damping, filter time and hysteresis are adjustable, and the sensor can easily be adapted to any use.

The FlowSwitch FS 510 is known as the most robust flow monitor of its class. It is made of stainless steel and optimized for a long lifetime. High ATEX ratings and adapters for high pressure allow use in the most difficult environment.

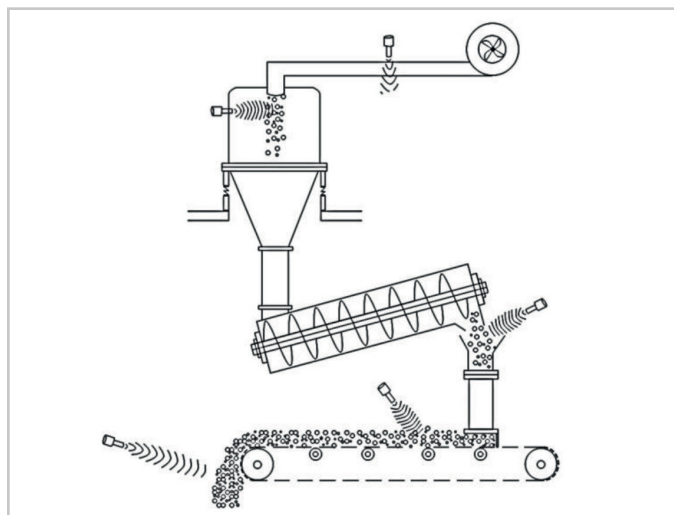

Technical Data

Housing material	Stainless steel (1.4307)
Sensor surface	Teflon (optional ceramic)
Ambient temperature	-20°C to +60°C
Process temperature	-20°C to +85°C
Process pressure	6 bar (optional 30-60 bar)
Protection class	IP65
Ex protection / ATEX	Optional up to Zone 20/21
Power supply	24 VDC (18 - 30 VDC)
Current consumption	Ca. 80 mA at 24 VDC
Transmitting power	10 dBm
Output (switching)	1x Relay contact (change-over contact, potential free) 1x NO ready contact
Switching voltage	30 VAC or 30 VDC
Switching current	min. 10 µA & max. 2 A
Switching power	30 VA or 30 W
Electr. connection	Plug-in screw terminals
Adjustable parameter	Amplification, filter, hysteresis, delay, min / max switches
Parameterization	Direct at device via buttons
Indicators	LED green (working) LED yellow (switch) Bar graph (e.g. field intensity)

