

Service manual

MF3000 Ex

Mass flow measuring system for solids



Manual for MF3000 Ex

MF-SMART-program for calibration and parameterization

No. MSBA00063-20
Date: 07/2020

Manufacturer:

Mütec Instruments GmbH
Bei den Kämpfen 26
21220 Seevetal
Deutschland



License, trademark and copyright notes

Windows™ is a registered trademark of Microsoft Corp.

Copyright © Mütec Instruments GmbH 2020 All rights reserved

This document is copyright protected. It supports the user in making reliable and efficient use of the unit. Reproduction and distribution of this document as well as utilization and disclosure of its content are prohibited unless expressly permitted. Any breach or infringement shall result in liability for damages. The software described in this document is licensed and may only be used and copied in accordance with the terms of the license.
All rights reserved.

Disclaimer

We have checked the content of the printed document for compliance with the described hardware and software. Nevertheless, deviations cannot be excluded and consequently we cannot assume any guarantee for complete accordance. The data in this printed document are checked regularly. Corrections and additions are made in the following version in each case. We would be grateful for any suggestions for improvement.

Subject to technical modifications

Contents

1. Classification of the safety instructions	4
2. General instructions	5
3. General information for installation and operation	6
4. Technical Data	8
4.1. Dimensions of the housing	9
5. Terminal connections	10
6. System structure	11
6.1. Jumper Configuration	12
6.2. Block Diagram of MFI 3000	12
7. Mounting and Assembly	13
8. Function Description	16
9. Calibration of Measured Value	17
10. Configuration Program MF-SMART	18
10.1. Read device settings	18
10.2. Products: measurement range.....	19
10.3. Products: Input calibration	20
10.4. Products: Digital outputs.....	22
10.5. Analog output.....	23
10.6. System.....	24

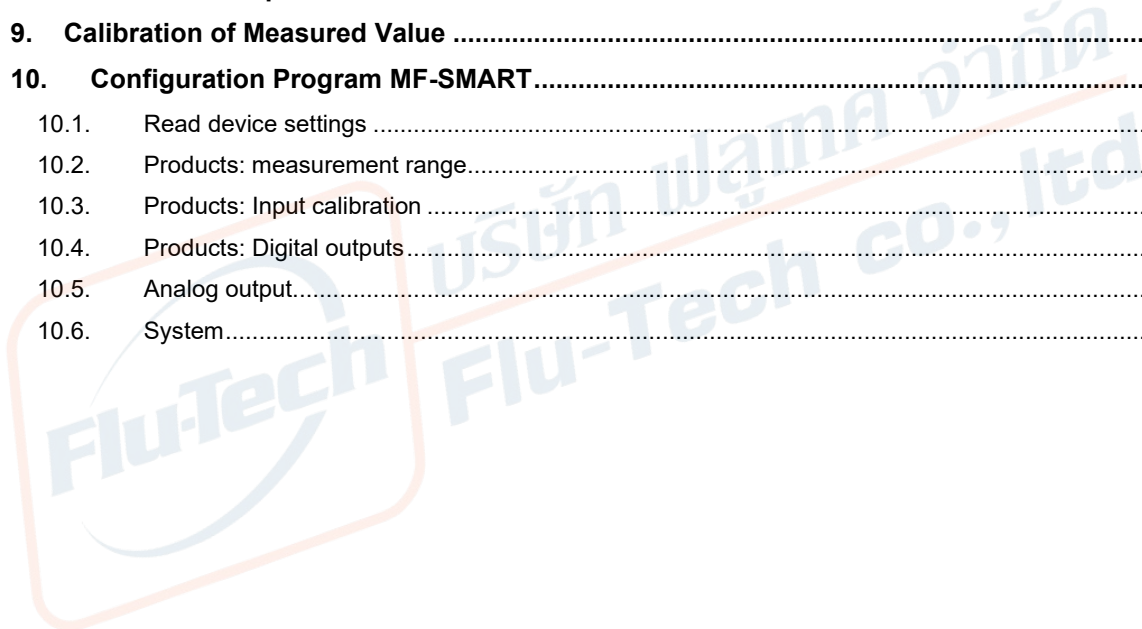

1. Classification of the safety instructions

This manual contains instructions that you have to observe for your personal safety as well as to avoid material damage. These instructions are highlighted using a triangular warning sign and shown as follows, depending on the degree of risk.



HAZARD

means that death or severe physical injury will occur if the appropriate precautionary measures are not taken.



WARNING

means that death or severe physical injury may occur if the appropriate precautionary measures are not taken.



CAUTION

with a triangular warning sign means that minor physical injury may occur if the appropriate precautionary measures are not taken.

CAUTION

without a triangular warning sign means that material damage may occur if the appropriate precautionary measures are not taken.



ATTENTION

means that an undesired result or state may ensue if the corresponding instruction is not followed.



NOTE

denotes important information about the product, handling of the product or the respective part of the documentation, is aimed at drawing special attention to the latter and should be complied with.

In addition to the instructions in this manual, the generally applicable safety and accident prevention regulations must be observed.

If the information contained in this document should not be sufficient in any specific case, you can obtain more detailed information from our telephone service.

Please read this manual carefully prior to installation and commissioning.

2. General instructions

This device left the plant in flawless condition in terms of its safety features. To preserve this condition and to ensure safe operation of the device, the user has to observe the instructions and warning notes indicated in this operating manual.

NOTE



For the sake of clarity the manual does not contain complete detailed information on all product types and can therefore not take into account every conceivable case with respect to installation, operation and maintenance.

If you wish further information or should special problems arise that are not treated in sufficient detail in the manual, you can obtain the necessary information by telephone.

Moreover, we point out that the content of the manual shall not constitute part of or amend a previous or existing contract, agreement or legal relationship. All obligations of Mütec Instruments GmbH shall result from the respective contract of purchase, which also contains the complete and solely valid warranty terms. These contractual warranty terms shall neither be extended nor limited by the information contained in the manual.

The content reflects the technical status at the time of printing. It is subject to technical modifications in the course of further development.

DISCLAIMER

All modifications to the device fall under the responsibility of the user unless expressly specified otherwise in the operating manual.

Qualified PERSONNEL

are persons who are familiar with installation, assembly, repair and operation of the product and have the qualifications necessary for their work, such as:

- Training, instruction and/or authorization to operate and maintain equipment/systems in accordance with the standards of safety technology for electrical circuits, high pressures and corrosive as well as hazardous media.
- In the case of equipment with explosion protection: training, instruction and/or authorization to perform work on electrical circuits for potentially explosive equipment.
- Training or instruction in accordance with the standards of safety technology regarding care and use of appropriate safety equipment.



CAUTION

Potentially electrostatic components may be destroyed by voltage that is far below the limits of human perception. Such voltage occurs even when you touch a component or electrical connections of a component and are not electrostatically discharged. The damage that occurs to a component because of overvoltage usually cannot be detected immediately and does not become noticeable until after a longer operating period.

3. General information for installation and operation

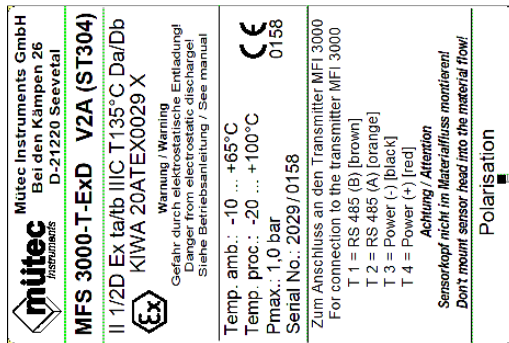

Fig. 1

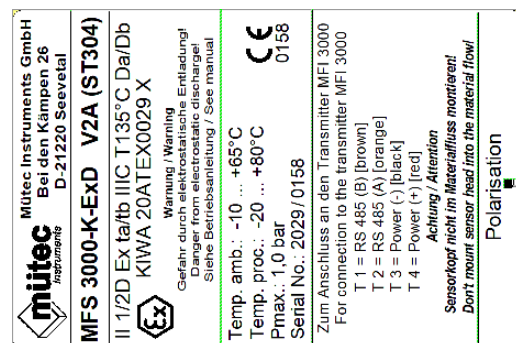



Fig. 2

Identification in accordance with directive 2014/34/EU for use in dust explosive areas:

	Explosion protected
II	Equipment group: equipment for non-mining applications
1/2	Equipment category: very high / high level of protection (equipment with partition wall)
D	Type of explosive atmosphere: dust

Identification of type of protection:

Ex	Explosion protection
ta/tb	Type of protection: protection by enclosures, incl. level of protection: ta/tb (equipment with partition wall)
IIIC	Dust group: conductive dust
T135°C	Maximum surface temperature: 135°C
Da/Db	EPL (Equipment Protection Level): Very high / high level of protection (dust)

Identification in accordance with directive 2014/34/EU for use in gas explosive areas:

	Explosion protected
II	Equipment group: equipment for non-mining applications
3	Equipment category: normal level of protection
G	Type of explosive atmosphere: gas, vapor, mist

Identification of type of protection:

Ex	Explosion protection
ec	Type of protection: increased safety
IIC	Gas group: highest requirements (most explosive gases)
T4	Temperature class: maximum surface temperature = 135°C
Gc	EPL (Equipment Protection Level): Enhanced level of protection (gas)

CE mark

This product meets the specifications according to the EMC-directive 2014/30/EU and the ATEX-directive 2014/34/EU.

Safety instructions:

If it is ascertained that safe and reliable operation is no longer possible, the device must be taken out of operation and has to be secured against accidental operation.

Reasons for this can be:

- visible damage of the device
- failure of electrical function
- storage at temperatures over 85 °C for a longer period of time
- heavy transport stress

Before the device can be put back into operation, a professional routine check must be performed in accordance with DIN EN 61010, Part 1. This examination should be necessarily carried out by the manufacturer. Repair work at Ex devices may be accomplished only under attention by §9 of the Ex regulation (Elex V).

Proper Use



The **MF3000 Ex** system consists of the sensor **MFS3000 Ex** and the transmitter **MFI3000** and is intended to measure the mass flow of solids in free fall or pneumatic pipes.



WARNING

The maximum permissible ambient and process temperature for the sensor **MFS3000 Ex** must be observed. This must not exceed the temperature range, specified in the technical data, chap. 4.

The maximum permissible ambient temperature for the transmitter **MFI3000** must not exceed the temperature range, specified in the technical data, chap. 4.

Type	Area	Identification	Certificate-no.
MFS3000-K-ExD MFS3000-T-ExD	Dust-Ex	 II 1/2D Ex ta/tb IIIC T135°C Da/Db	KIWA 20ATEX0029 X
MFS3000-K-ExG	Gas-Ex	 II 3G Ex ec IIC T4 Gc	KIWA 20ATEX0030

Installation and operation



WARNING

For the safe operation a protective grounding connection to the sensor MFS3000 Ex has to be established, to ensure a permanent integration into the potential equalization.

The assembly/disassembly, installation, operation, and maintenance may only be performed by qualified personnel in the automation industry under appropriate regulations and the MF3000 Ex service manual.

The technical data and the power supply information must be considered during installation.

Maintenance:

The device maintenance should be done with a dry cloth and it is not allowed to use any solvents.



Warning

Rubbing on the name plate (e.g. during cleaning) can lead to electrostatic charging and represents an ignition hazard! It must be ensured that there is no friction in the presence of an ignitable atmosphere.

4. Technical Data

Flow Sensor MFS3000-Ex

Medium touched parts:	Stainless steel 1.4307 or 1.4571 (optional) and PA 6.6GF30 (MFS300-K-Ex*) or PTFE (MFS3000-T-ExD)
Process connection:	Welding branch
Housing material:	Stainless steel 1.4307 or 1.4571 (optional)
Protection class:	IP 65
Transmit frequency range:	24.150 ... 24.250 GHz
Transmit power:	12.7 dBm

ATEX:

Thermal data

Permissible ambient temperature:	-10 to +75°C (MFS3000-*-Ex*)
Permissible process temperature:	-20 to +80°C (MFS3000-K-ExD and MFS3000-K-ExG) -20 to +100°C (MFS3000-T-ExD)
Surface temperature:	max. 135°C

Electrical data (maximum values)

<i>Current supply circuit (clamps 3 and 4)</i>	
Voltage	16 ... 24 VDC
Current	25 mA

<i>RS485 interface current circuit (clamps 1 and 2)</i>	
Voltage	6 VDC
Current	50 mA

Applied standards:

EN IEC 60079-0:2018, EN 60079-7:2015, EN 60079-31:2014

Transmitter MFI3000

Analog output

Current:	0 ... 20 mA
Output value:	max. 22 mA
Load:	max. 750 Ω
Accuracy:	≤ 0,02 % of the final value
Load influence:	≤ 0,01 %
Response time:	≤ 150 ms
Damping:	filter 1 st order for (0,1 - 99)s; adjustable
Voltage:	0 ... 10 V
Output value:	max. 11 V
Load:	min. 50 kΩ
Accuracy:	≤ 0,02 % of the final value
Load influence:	≤ 1 % at 50 kΩ
Response time:	≤ 150 ms
Damping:	filter 1 st order for (0,1 - 99)s; adjustable

Pulse output

Operational mode:	Open-Collector, open-circuit principle
Switching capacity:	≤ 1,4 W
Switching voltage:	≤ 28 VDC
Switching current:	≤ 50 mA
Pulse duration:	≤ 50 ms

Alarm relay

Operational mode:	normally opened or normally closed
Alarm function:	MAX, MIN oder sensor fault
Fail-LED/red:	permanent light → limiting value alarm
Relay contact:	1 opener or closer
Switching capacity:	max. 30 VA at AC, max. 15 W at DC
Switching voltage:	max. 30 VDC or 125 VAC
Switching current:	max. 0,5 A
Min-Contact voltage:	10 mVDC
Min-Contact current:	10 µA
Contact material:	AgPd+Au or PdRu+Au

Interfaces

USB:	Front socket connection (USB-B mini) for PC/Notebook
RS485:	2400, 4800, 9600 or 19200 bps, device address: 1-255

Power supply

Type:	energy supply class A.C.3 or D.C.4 by IEC 654 part 2
AC:	24 VAC, -20% to +20 %, 50-60 Hz
DC:	24 VDC, -20 % to +30 %
Power consumption:	max. 2 W
Power-LED/green:	<i>good condition of the supply</i>

Electromagnetic Compatibility

This product meets the specifications according to the EMC directive 2014/30/EU.

More Data

Fail-LED/red:	slow blink → no sensor connection fast blink → FRAM-memory error
Form of construction:	Housing for 35 mm DIN rail (EN 50022)
Dimension:	22,5 x 99 x 114,5 mm
Ambient temperature:	-10 to +60°C
Protection class:	IP 20
Weight:	150 g

4.1. Dimensions of the housing

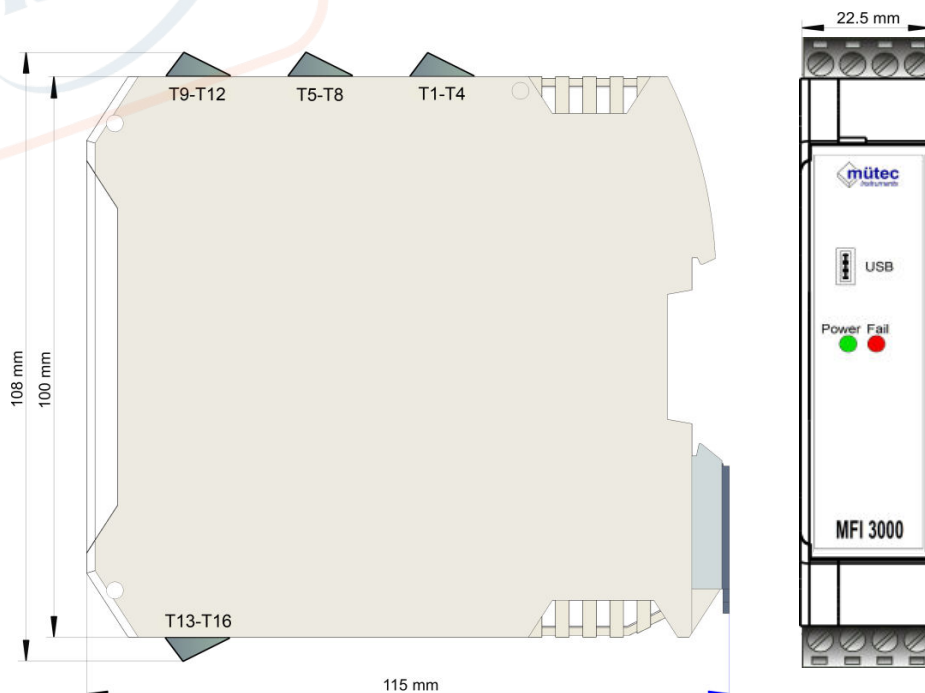

Fig. 3

5. Terminal connections

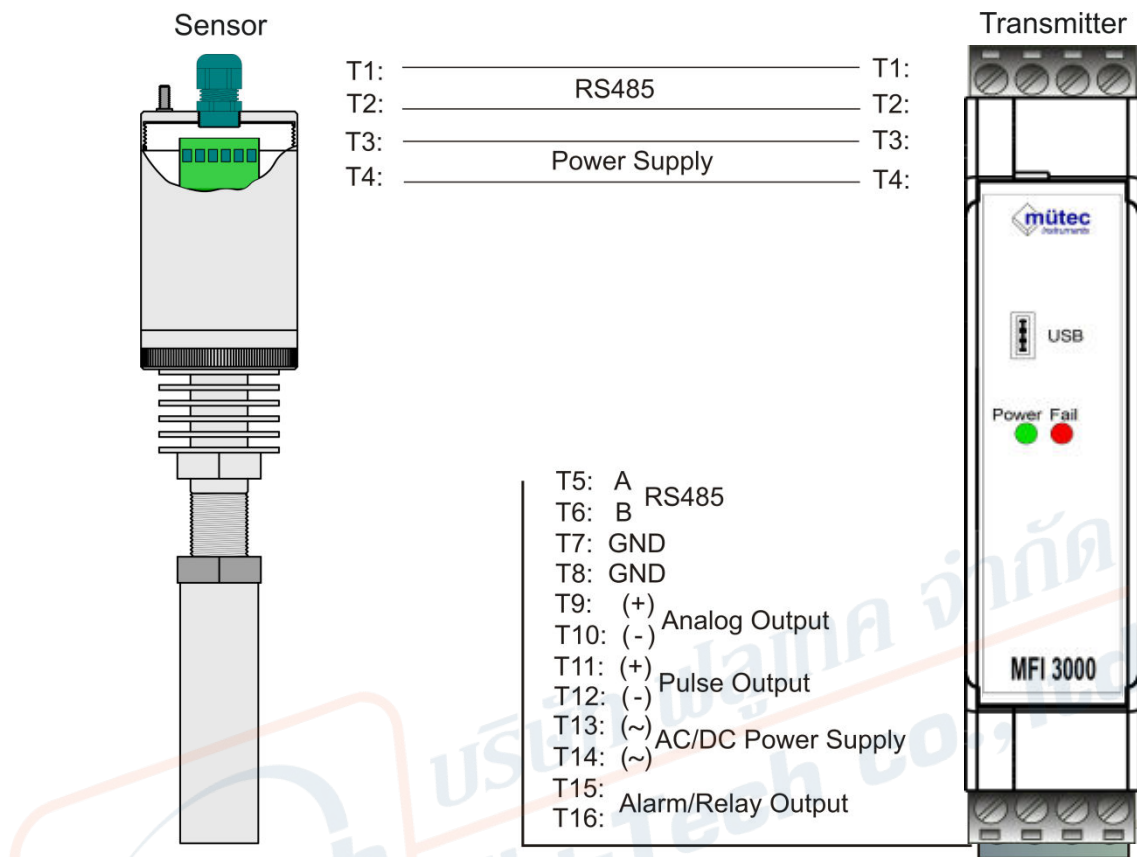

Fig. 4

6. System structure

The system **MF3000-Ex** consists of a cylindrical flow sensor with welding flange, a DIN-rail transmitter and the software **MF-SMART**. The process interface is realized by the welding branch, in which the sensor is screwed flush with the inside of the pipe. The sensor is connected to the transmitter by a 4-wire cable. The transmitter contains an analog output, a pulse output, an alarm relay output, as well as a USB and a RS485 interface.

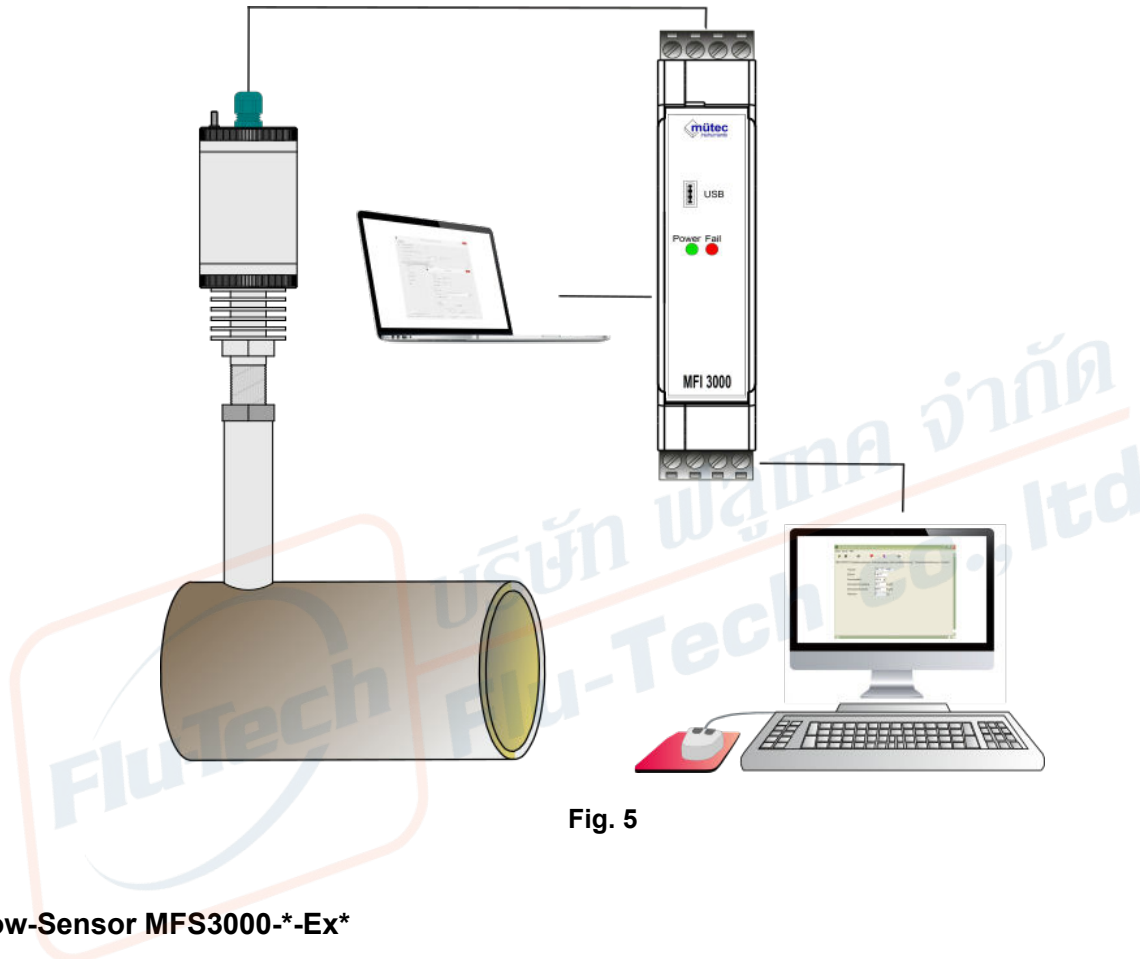

Fig. 5

Flow-Sensor MFS3000-*-Ex*

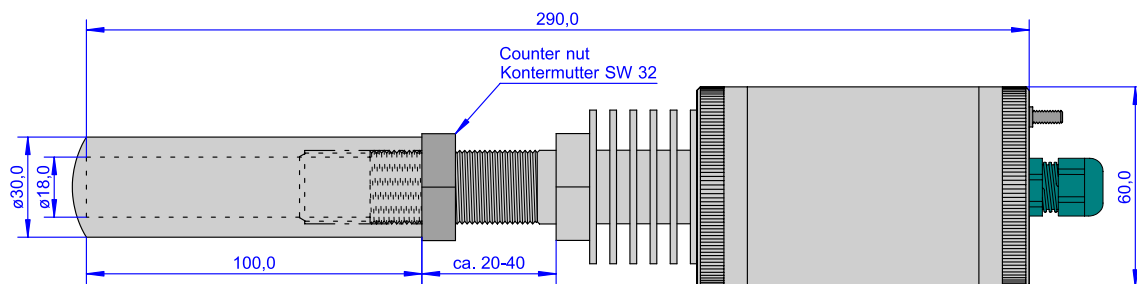
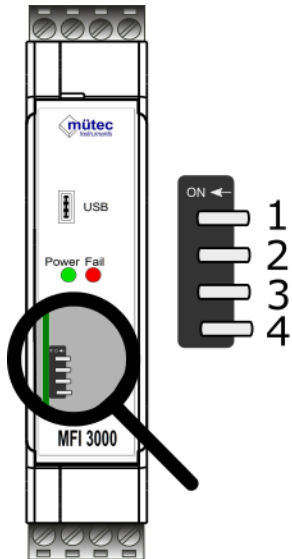

Fig. 6

6.1. DIP-Switch Configuration

The output signal can be configured via a DIP switch behind the front panel. After carefully removing the front panel, the following switch positions can be used to make settings for the RS485 interface and analog output:



- Switch 1/2: Switch to ON for RS485 interface termination.
- Switch 3: Defines the analog output mode
4-20 mA DC current (Schwitsch 3 OFF) or
0-10 V DC voltage (Switch 3 ON)
- Switch 4: not connected

Fig. 7

6.2. Transmitter MFI3000 Block Diagram

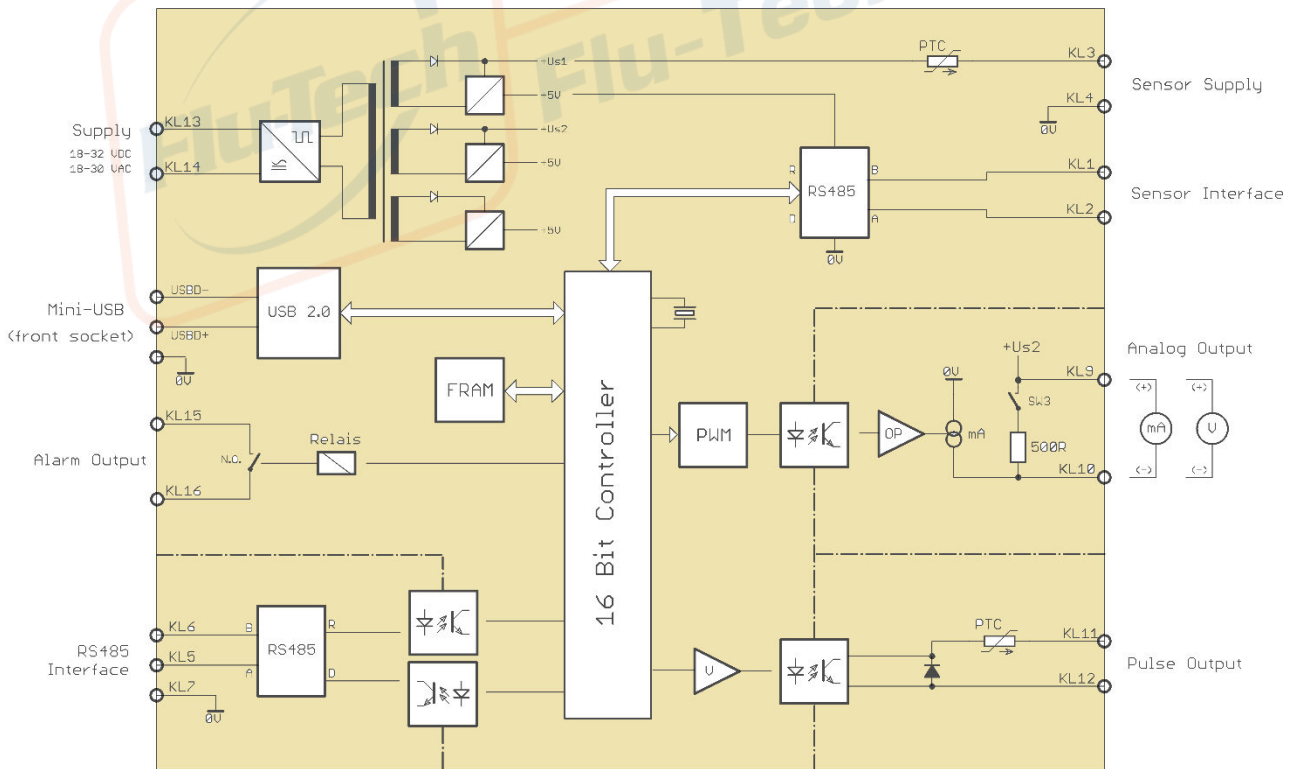

Fig. 8

7. Mounting and Assembly

Scope of delivery

- Flow sensor **MFS3000*-Ex***
- Transmitter **MFI3000**, DIN-rail mountable
- Software **MF-SMART** for Windows
- Installation manual
- USB interface cable (USB-A to USB_B mini)
- Welding branch for the flow sensor (optional)

Preparation for sensor assembly

A welding device and a drilling machine (drill = 18 mm \varnothing) are needed for the installation. Some important notes should be observed, regarding the choice of the optimal installation position. The welding branch can be installed into a horizontal transport line or into a vertical free fall line.

The assembly is always expedient into a free fall line. The vertical line tracing has to be preferred upward in case of air conveying lines.

The distances of the inlet/outlet pipe to the **MFS3000*-Ex*** shouldn't fall below the following distances as a multiple of the nominal diameter (DN).

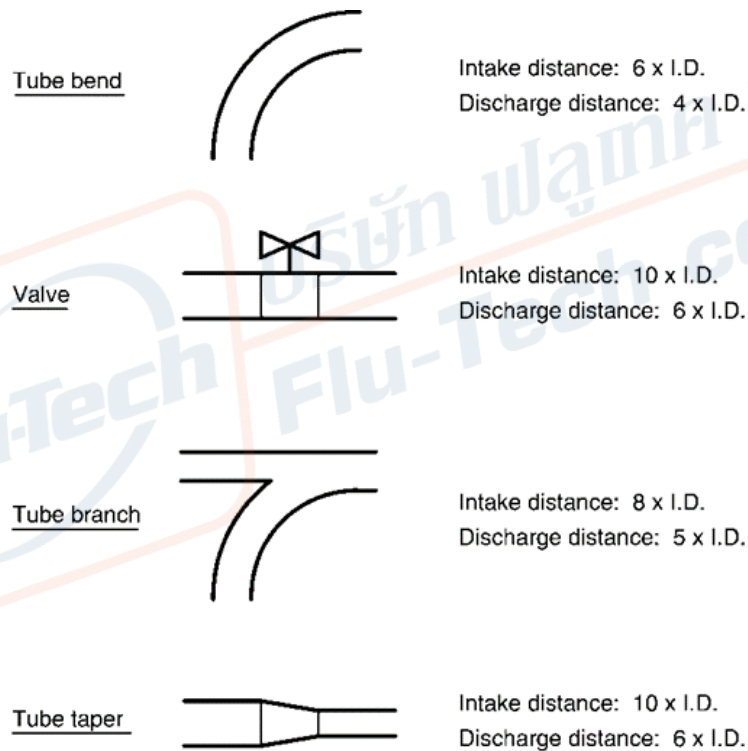

Fig. 9

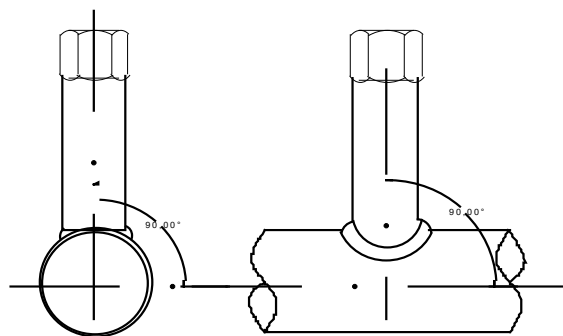

Fig. 10

The split between welding branch and pipe wall has to be closed by a weld seam after fixing the flow sensor flange vertical and in a 90° angle to the pipe axis.

The quality of the welding seam can be checked by a following pressure test. For boring out the pipe wall for the necessary measuring window, an 18mm drill is needed. The welding branch which has been welded on before can be used as drilling jig. After the drilling, the hole has to be deburred thoroughly, to avoid material deposits at the sensor.

In a vertical pipe the flange will be placed horizontal and also in the 90° angle to the pipe axis.

Flow Sensor Mounting

Before screwing in the flow sensor into the welding branch, the total depth of welding branch and pipe thickness should be marked at the shaft of the flow sensor.

The measuring window shall be mounted flush with the pipe wall so that it doesn't reach into the pipe. The screwing of the flow sensor into the welding branch occurs up to the marked line. The use of Teflon ribbon is recommended for the better insulation. The polarization axis indicated on the type plate is aligned in parallel to the pipe axis. A firm attracting of the jam nut (wrench size 32) on the thread shaft fixes the flow sensor permanently.

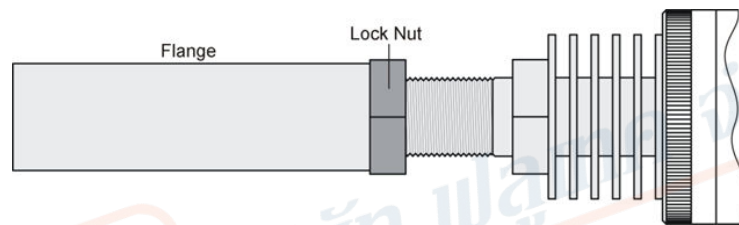

Fig. 11

Electrical connection and wiring

The DIN-rail transmitter **MF13000** always should be installed in a switch cabinet or dry room and it has to be supplied with 24V AC/DC. The electrical connection between the flow sensor and the transmitter has to be executed as a 4-wire cable. For wire lengths up to 60 m a wire cross-section of 0,75mm² is sufficient. Beyond this it is necessary to apply > 1,0 mm² proportionally to wire length. A standard shielded cable can be used.

NOTE



For an easy ground point connection, a PE-connection (M4 threaded bolt) is available at the housing.



WARNING

The flow sensor must not be opened when energized!

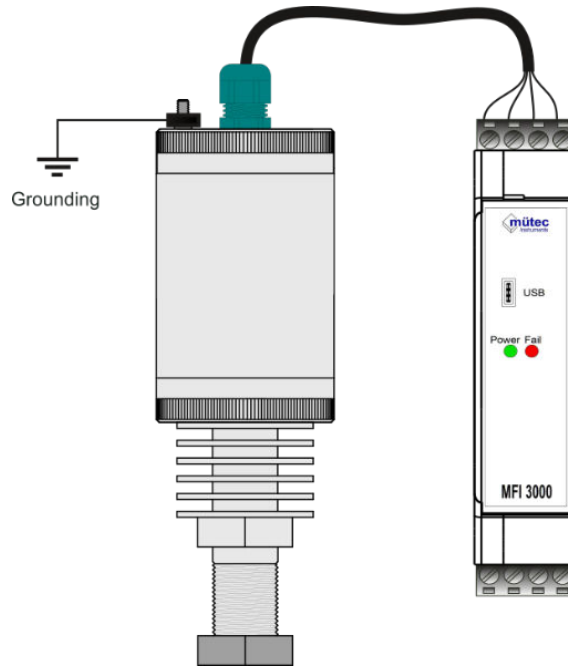

Fig. 12

To avoid potential equalization currents on the shielded wiring it has to be grounded only at one end of the cable. For practical reason this should always be carried out on the transmitter side. For the wiring at the flow sensor the cable sheath and the shielded wiring must be removed. With a piece of shrinkage tube slid over the end of the cable sufficient insulation of the shielded wiring to the screwed cable gland or housing is achieved and an undesired grounding contact can be avoided.

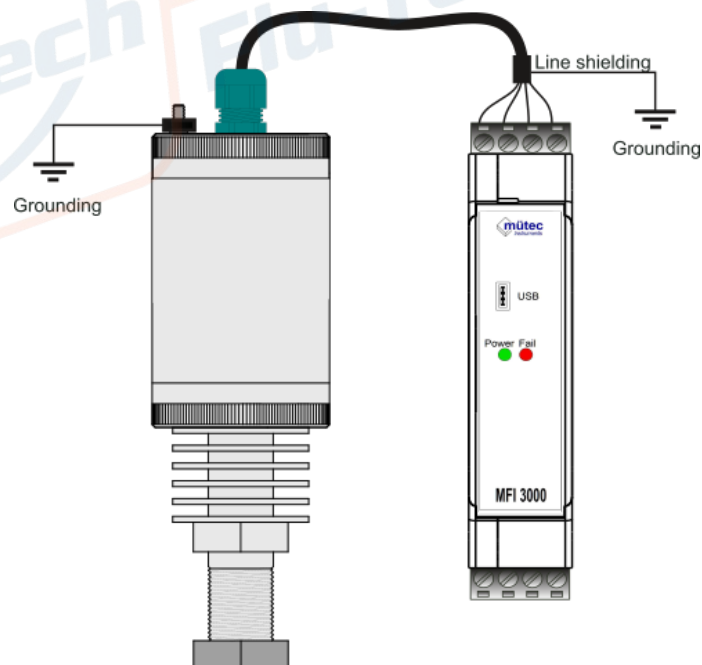

Fig. 13

8. Function Description

The **MF3000*-Ex*** system is designed for the flow measuring of solid substances in metallic pipelines. It enables the flange mount at vertical pipes at the free-fall transport and at horizontal pipes at the pneumatic material transport. Equipped with the newest microwave technology, a modern K band transceiver is used. As a result, the supply current for the **MF3000*-Ex*** sensor could be reduced to less than 25 mA. The working frequency of the probe lies in the internationally free available frequency area between 24.15 ... 24.25 GHz, in which the maximum radiated power is less than 20 mW. An at the pipe welded installation flange, through which the pipe wall will be drilled afterwards, serves as a mechanical mount for the **MF3000*-Ex*** sensor. From the flush mounted **MF3000*-Ex*** inside of the pipe, the microwave will be radiated into the metallic pipeline which serves as a measuring chamber. The radiated wavefronts meet the flowing solid substances and lead to a frequency displacement (Doppler effect) of the reflected signal. The intermediate frequency signals, whose frequency and amplitude are proportional to speed and size of the solid substance parts, will be collected and used as basis for the calculation of the solid substance quantity. Deposits at the pipe wall will not influence the measurement.

Placed in a stainless steel housing, the measuring sensor is connected to the **MF13000** transmitter by a 4-wire cable and can be parameterized and calibrated online by a RS485 interface.

The raw measuring value of the solid substance quantity is transmitted for analysis to the transmitter. The result is provided as an analogue 0/4-20mA- or 0/2-10 V- signal or as a digital process value at the RS485 interface.

A passive pulse output enables the external integration of the solid substance quantity. A relay output is used as the min/max alarm or can be used for sensor monitoring. After parameterization and calibration of the **MF3000*-Ex*** system, the measuring value can be observed at the online-mask or by using the data logger of the software **MF-SMART**.



Fig. 14

9. Calibration of Measured Value

After the installation of the software **MF-SMART**, it is possible to parameterize the **MF3000*-Ex***. For exact measurements, a multipoint calibration is essential. At least two reference measurements with a known quantity of bulk material are necessary.

In case of a calibration for 3 to a maximum of 10 calibration points, the different reference quantities or weighing equipment are needed accordingly.

- Convey or fill quantity 1 with constant pressure and constant speed into the free fall pipe
- The calibration routine for the first calibration point will be started with the installed software **MF-SMART** on the PC. The measured raw value will be determined and assigned to the real mass flow (the reference value).
- For the second calibration point and the second quantity, repeat the steps in the same way.

2-point-calibration linear characteristic curve:

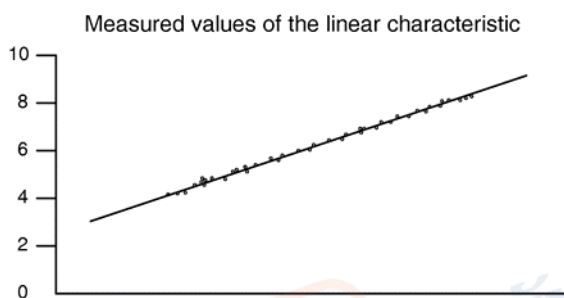

Fig. 15

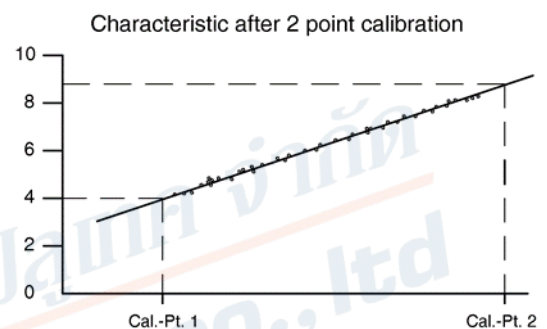

Fig. 16

Calibration of 3 points or more

In case of pneumatic and free fall conveyance, the flow structure changes according to the conveyed quantity. Therefore the curve won't be a linear function in most areas of the measuring range. It has to be compensated by a piecewise linear function. Up to 10 linearization points are available.

3-point-calibration for non linear characteristic curve:

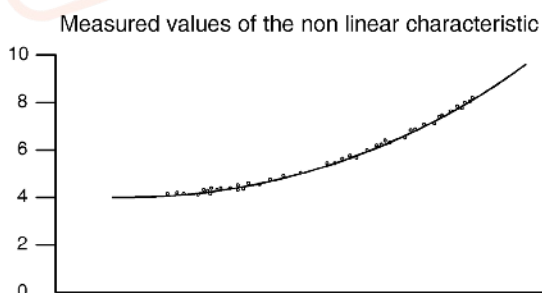

Fig. 27

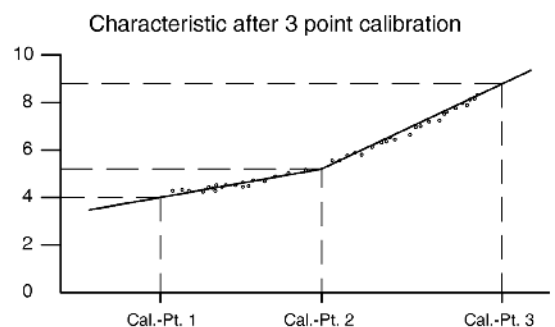

Fig. 38

10. Configuration Program MF-SMART

10.1. Read device settings

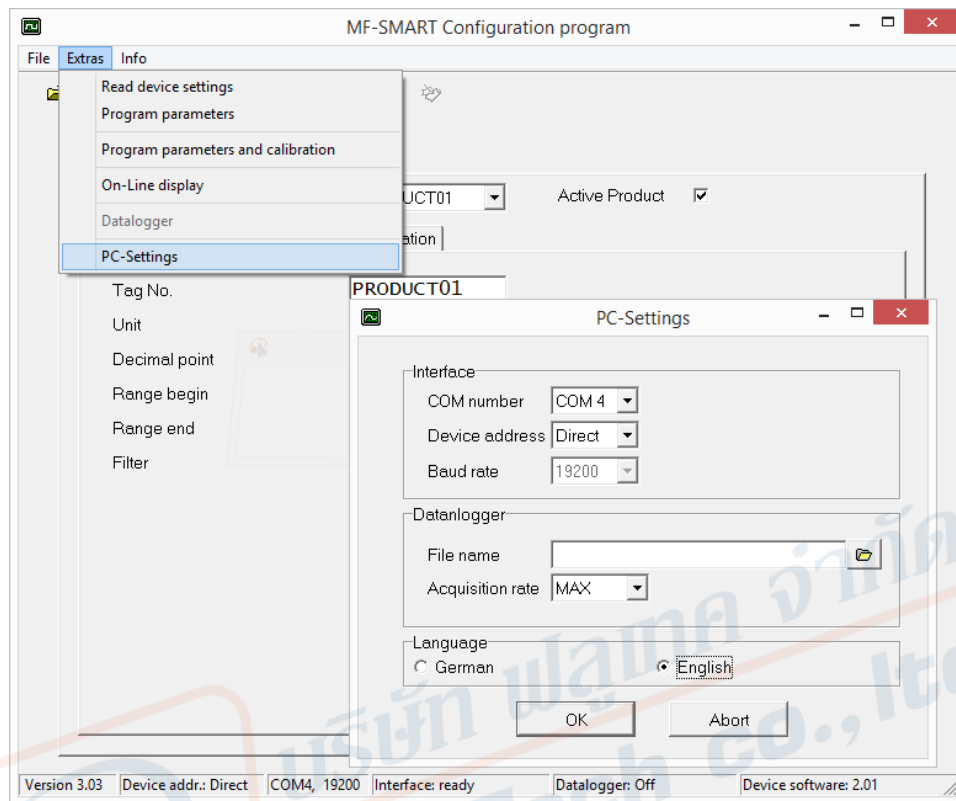

Fig. 49

Extras:

Read device settings
Program parameters
Program parameters and calibration
Online-display

- read in all **MF13000** - device data
- write parameter from PC-program in **MF13000**
- Parameter and calibration values from PC-program write in **MF13000**
- display with layout of raw measuring values (unfiltered + filtered) and integrator

PC-Settings:

USB
Device address:
USB-front socket
RS485-Interface
Baud rate

- Virtual serial interface COM1 ... COM10
- **MF13000**-device address: direct
- **MF13000**-device address: 1... 255
- 19200 bps (fixed)

Data logger:

File name
Acquisition rate

- File name for stored measuring values
- 5 measuring values/h, 20 measuring values/min to 1 measuring value/s (max)

10.2. Products: measurement range

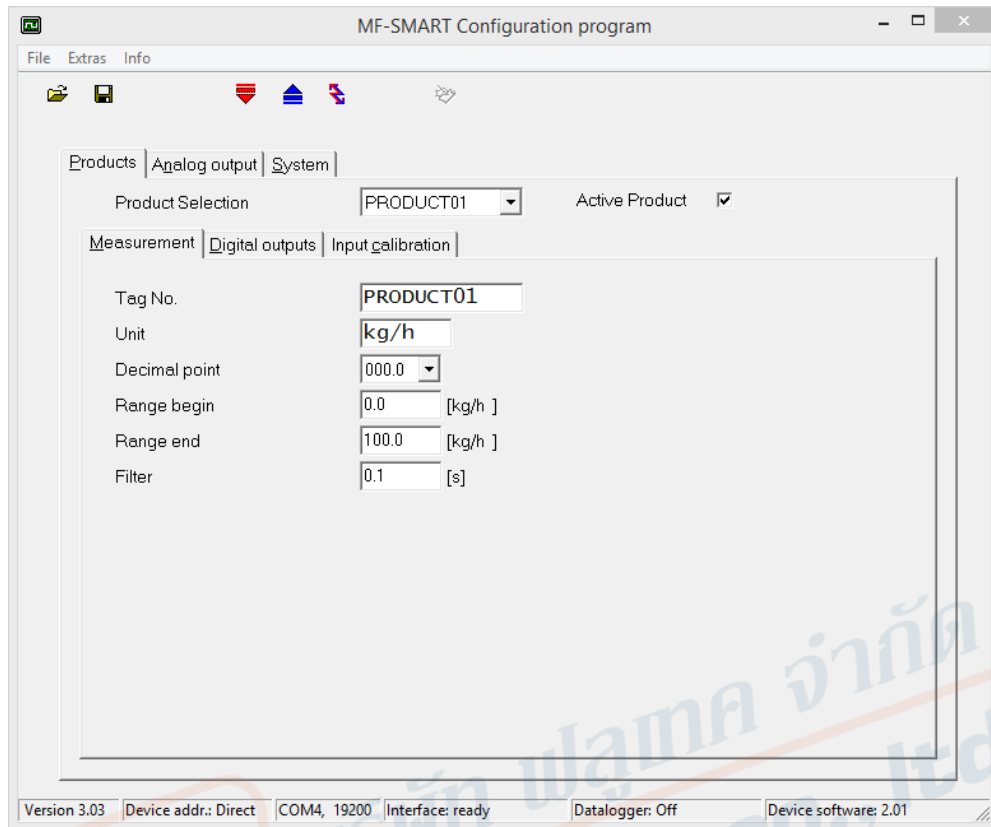

Fig. 20

The initial input mask of the **MF-SMART**-configuration program shows the available displays for parameterization, calibration and online presentation.

Parameterization for measurement settings:

Product selection	-	Selection between 1 ... 24
Tag No.	-	Device-No. of MF13000
Unit	-	Measuring unit of flow rate
Decimal point	-	0 to max. 3 decimal places
Range begin	-	0 % - value of measuring range
Range end	-	100 % - value of measuring range
Filter	-	Filter 1 st order between 1 ... 500 s adjustable

Information about status bar:

Version 3.xx	-	MF-SMART program version
Device address	-	MODBUS-address: direct or 1 255
COM1, 19200	-	PC-interface COM-1 with Baud rate 19200 bps
Interface status	-	Status of PC-interface
Data logger	-	Data logger is off
Device software	-	Program version of MF13000

Changed parameters will be lost when you leave the screen mask. They will be transferred and stored in the MF13000 by the instruction **Extras/Program parameters**.

Max. 6 characters are available for the text of measuring unit. Unused characters must be padded with blanks and have to be deleted first in case of a later text change.

With each change of the decimal place, an already registered value shifts the beginning and end of the measuring range by a decade. These values have to be corrected, if necessary.

10.3. Products: Input calibration

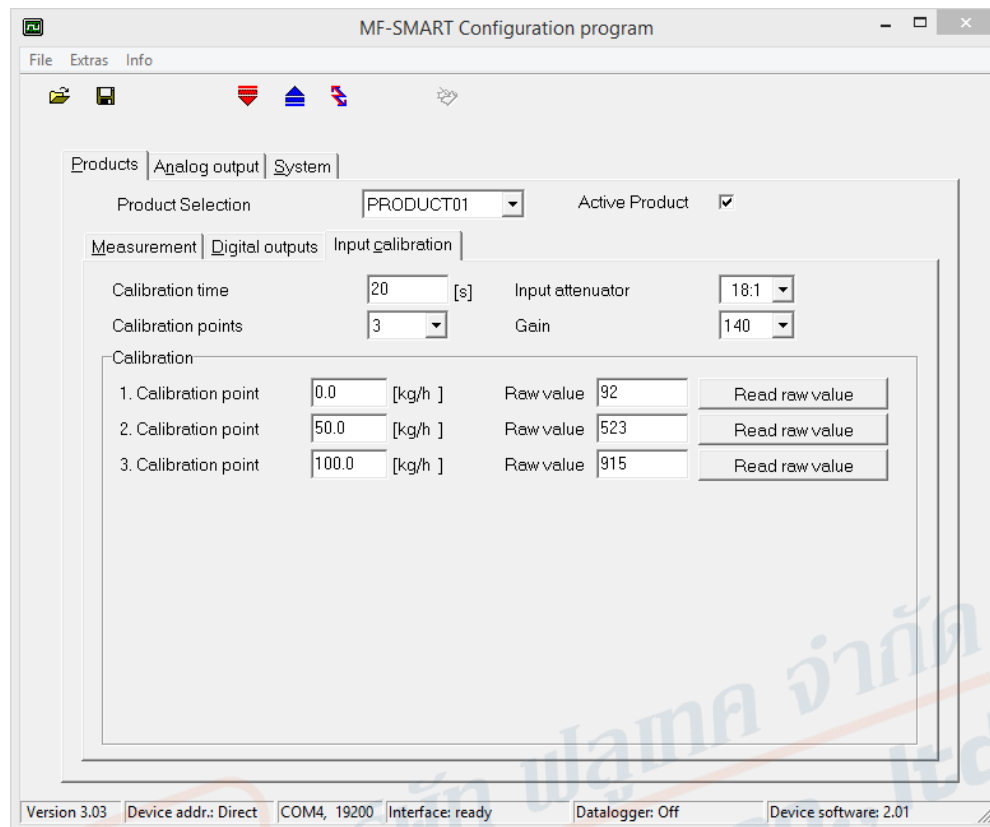

Fig. 21

Calibration of measuring value:

Calibration time
Number of calibration points
Input attenuator
Gain
1. / 2. Calibration point/
Read raw value

- Filter 1st order adjustable between 1 ... 999 s
- 2-point-calibration for linear characteristic line or up to 10-point-calibration for not linear characteristic curve
- 4 dividing factors: 140:1, 70:1, 18:1 and 1:1 enable an optimal input signal adaption
- available gain factors between 70 and 1280
- The raw value can be inserted manually or automatically by using the button **read raw value**

Any calibration value in the calibration mask must be stored first, before pressing another button in the screen mask.

Changed parameters and calibration values will be lost by leaving the screen mask. They will be transferred and stored in the MFI3000 by the instruction **Extras/Program parameters and calibration**.

Important information about sensor calibration:

The measured value is digitized by a 10-Bit ADC and consists of values between 0 and 1023. In order to avoid any distortion of the characteristic curve, the product of input attenuator and gain has to be adjusted in the way that the available value range of max. 1023 digit will not be exceeded. For a high measuring accuracy, the smallest possible input attenuator should be used in order to keep the adjustable gain factor small as well. The input attenuator and gain should be selected with respect to the digital value at the end of the measuring range (100 % - value).

The **Online**-display provides an online tracking of the digital raw value. Before the first calibration of a measuring value, only the raw value is valid in the **Online**-display. The indicated results for the measuring value and analog output value could be erroneous and cannot be used for the evaluation of the adjustment process. For the adjustment of the measuring range by input attenuator and gain factor the 100 % value should be at about 900 digit, in order to ensure a high resolution and to allow $1023 - 900 = 123$ digit for an overrange of the measuring value. After adjusting the measuring range, the calibration can be started. In case of a linear characteristic curve, the first calibration point should be next to the start of the measuring range and the second calibration point at about 90 % of the measuring range.

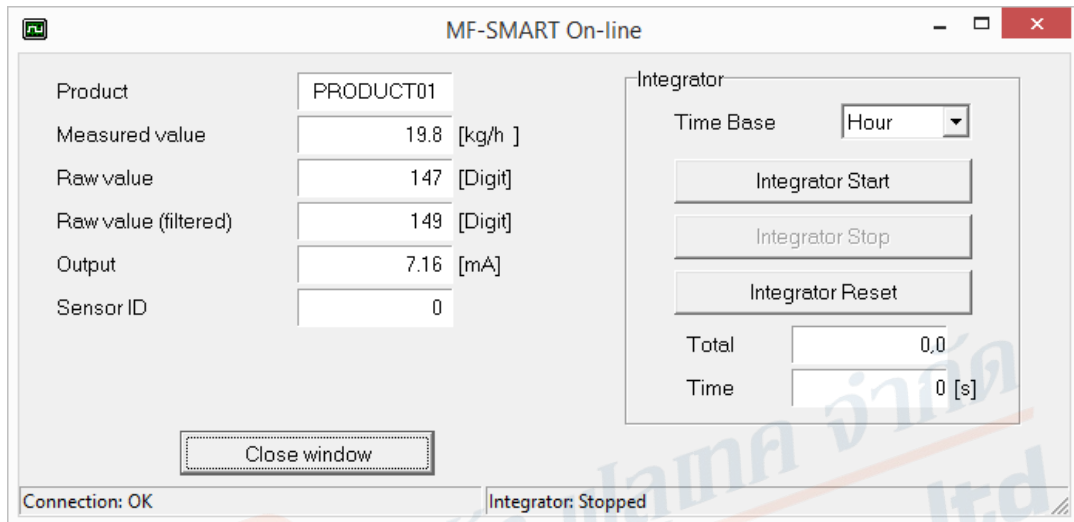

Fig. 22

Online mask:

Product	-	Product name
Measuring value	-	Parameterized quantity to be measured
Raw value	-	10 bit value of the measuring value
Raw value (filtered)	-	10 bit value of the measuring value after filtering
Output	-	Analog value
Sensor ID	-	Only as an option

Integrator:

Time Base	-	the time unit has always to correspond with the defined time base in the display measuring range
Integrator Start	-	Start button
Integrator Stop	-	Stop button
Integrator Reset	-	Reset button
Total	-	accumulated flow rate with the defined measuring unit in the display measuring range
Time	-	Running period of integrator

The function of the integrator is only available within the opened screen mask **MF-Smart On-line**.

10.4. Products: Digital outputs

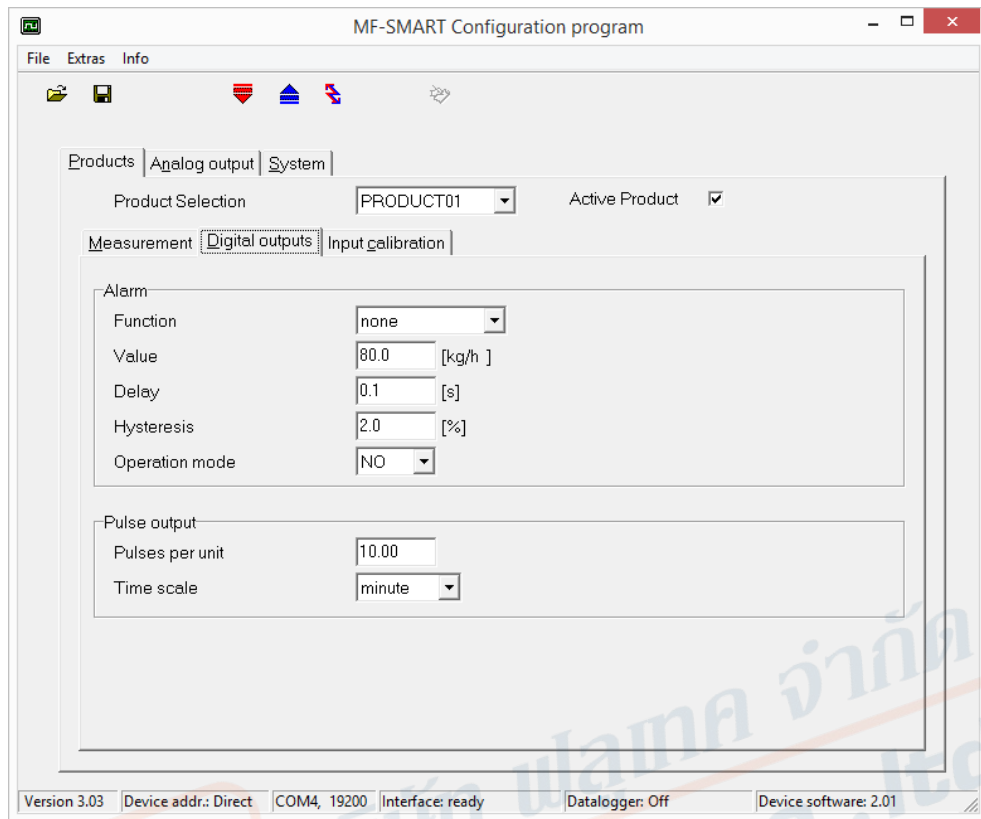

Fig. 53

Parameterization of the alarm output:

Function	-	MAX-, MIN- or sensor fault-alarm
Value	-	Trigger value of MAX- or MIN-alarm
Delay	-	Alarm delay from 0.1 to 99.9 s
Hysteresis	-	0.1 % to 99.9 % of measuring range
Operation mode	-	NO = normally opened NC = normally closed

Parameterization of the pulse output:

Pulse per unit	-	Estimation of flow rate from min. 0.01 to max. 99.99 pulses per flow rate unit
Time scale	-	According to the time entered in the screen mask measuring range

Example:	Measuring range:	40. to 800.0 kg/h
	Pulse per unit:	10 pulses/(kg/h)
	Time scale:	hour
=>	Pulse rate:	min. 400 pulses/h to max. 8000 pulses/h or min. 0.11 pulses/s to max. 2.22 pulses/s

The Pulse output should be parameterized in the way that at an averaged maximum flow rate a pulse rate of 10 pulses/s will not be permanently exceeded.
 Changed parameters will be lost by leaving the screen mask. They will be transferred and stored in the MFI 3000 by the instruction **Extras/Program parameters**.

10.5. Analog output

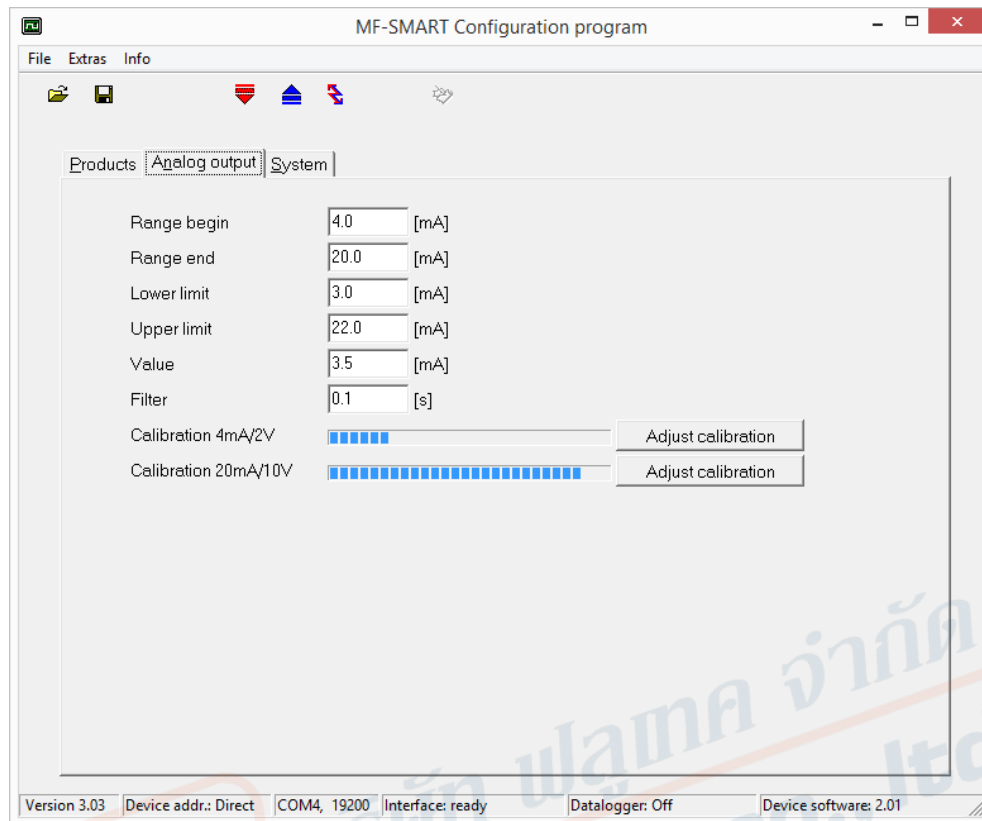

Fig. 24

Parameterization of the analog output:

- | | | |
|-----------------------------|---|--|
| Range begin | - | 0 % - value analog output signal |
| Range end | - | 100 % - value analog output signal |
| Lower-limit | - | minimal output signal |
| Upper-limit | - | maximal output signal |
| Value | - | output signal in case of no connection to flow sensor |
| Filter | - | Filter 1 st order, adjustable between 0.1 ... 99.9 s |
| Calibration 4mA/2V | - | After pushing the button adjust calibration the analog value-1 can be adjusted to 4.000 mA or 2.000 V and |
| Calibration 20mA/10V | - | the analog value-2 to 20.000 mA or 10.000 V. |

Changed parameters will be lost by leaving the screen mask. They will be transferred and stored in the MF13000 by the instruction **Extras/Program parameters**.

Analog output with constant current: DIP-switch 3 OFF!
 Analog output with voltage signal: DIP-switch 3 ON!

10.6. System

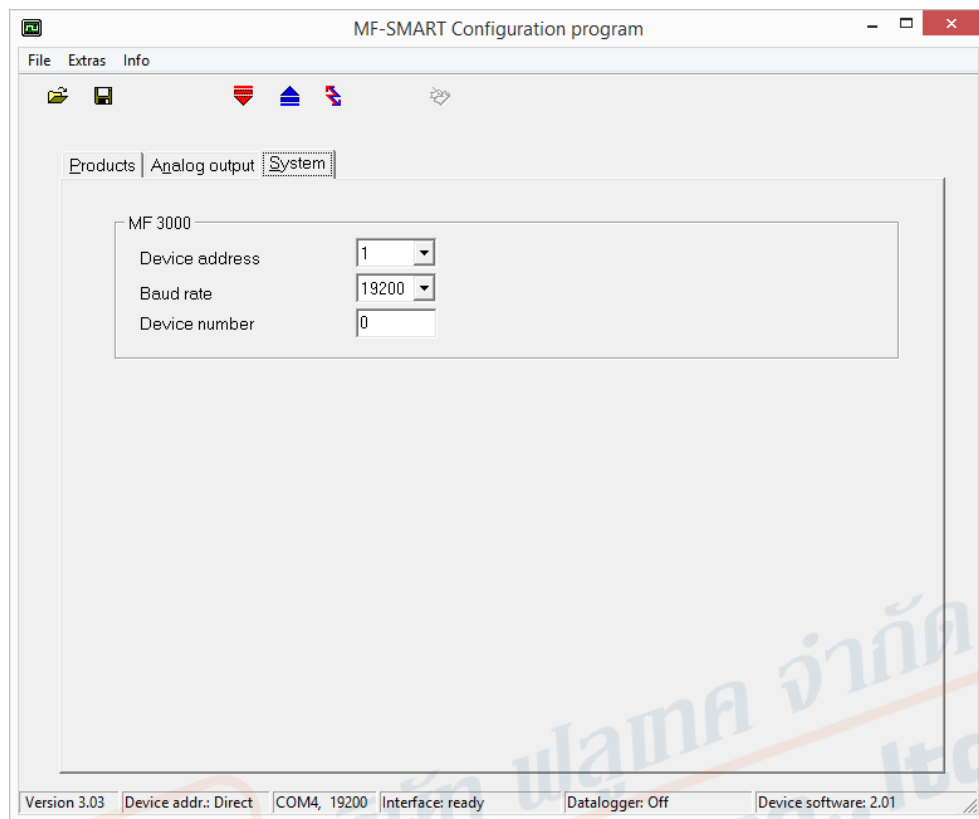

Fig. 65

MF3000/RS485-Interface:

- | | | |
|-------------------------|---|--------------------------------------|
| Device address | - | adjustable between 1 ... 255 |
| Baud rate | - | adjustable between 2400 to 19200 bps |
| Device number | - | max. 8 characters |
| Protocol (fixed) | - | MODBUS/RTU-Mode |

As part of a multipoint connection to a PC or process control system, the terminals T5/T6 provide a system connection with RS485 interface.

MF3000/USB-Interface:

With the program **MF-SMART** it is possible to access all parameters and variables of the system via the USB-front socket of the **MF13000** without the need for adjusting interface parameters.

The update of a changed baud rate will take place after a system reset by a short interruption of the power supply voltage.