

Operating instructions

MF3001



Flow measurement of bulk solids



Application

Many bulk material applications require continuous measurement of mass flow, e.g., for precise dosing of a material or to determine the mass flow into a container. However, many of the measuring systems used today, such as belt scales, impact plates, or bulk scales, are expensive, complex to install, and require intensive maintenance.

The MF 3001 microwave flow meter is the better alternative. It is designed for flow measurement in metallic pipes under pneumatic or free-fall conditions. The MF 3001 operates without contact and maintenance, is easy to retrofit, and is suitable for measuring all types of powder, dust, granules, and pellets.

MF 3001 manual

Doc. No.: 880

Revision: 1.0

Date of issue: January 12, 2026

Mütec Instrumente GmbH

Bei den Kämpfen 26

21220 Seevetal

Germany

License, trademark, and copyright notices

Copyright © Mütec Instrumente GmbH

All rights reserved

This document is protected by copyright. It supports the user in the safe and efficient use of the device. Distribution and reproduction of this document, exploitation and communication of its contents are prohibited unless expressly permitted. Any violation will result in claims for damages. The software described in this document is licensed and may only be used and copied in accordance with the license terms.

All rights reserved.

Disclaimer

We have checked the contents of the printed document for consistency with the hardware and software described. However, deviations cannot be ruled out, so we cannot guarantee complete consistency. The information in this printed document is checked regularly. Corrections and additions are made in the following version. We are grateful for any suggestions for improvement.

Subject to technical changes

Content

1	Safety instructions and installation	5
2	Classification of safety instructions	5
3	General instructions	7
4	Technical data	10
4.1	Transmitter.....	10
4.2	Sensor.....	13
5	Dimensions	14
5.1	Transmitter.....	14
5.2	Sensor.....	14
6	Intended use	15
7	Measuring principle	15
8	Sensor design	16
9	Installation	17
9.1	Transmitter installation.....	17
9.2	Electrostatic discharge.....	17
9.3	Mounting the sensor.....	18
9.3.1	Preparations for sensor installation.....	18
9.3.2	Installation of the sensor.....	19
9.3.3	Electrical connection and wiring.....	19
10	Electrical connection	21
10.1	Transmitter terminal assignment.....	21
10.2	Terminal block assignment.....	21
10.3	Cable installation.....	22
11	Commissioning	23
11.1	Switching on the measuring system.....	23
12	Notes for operation in potentially explosive atmospheres	23
12.1	Marking according to Directive 2014/34/EU:.....	23
12.2	Marking of sensors.....	24
12.3	Safety instructions.....	24
12.4	Installation in ATEX Zone 20/21 or Zone 2.....	25
12.5	Further information on sensor installation.....	25
12.6	Troubleshooting and repair.....	25
13	Introduction to the MFconfig software	26
14	Installation and configuration of the software	26
14.1	The start screen.....	26
14.2	Language selection.....	27
14.3	Selecting the access mode.....	27

14.4	Connecting the MFI 3001 transmitter to a PC	27
14.5	Selecting and activating the MFI 3001 transmitter	29
14.6	Deactivate transmitter	30
14.7	Remove device	30
15	Parameterization of the measurement system	31
15.1	Parameterization in standard mode.....	31
15.1.1	Transmitter settings.....	31
15.1.2	Products/Calibration	32
15.1.3	Online view	33
15.1.4	Offline analysis.....	37
15.2	Parameterization in expert mode.....	39
15.2.1	Transmitter settings (additional functions)	40
15.2.2	Digital inputs.....	41
15.2.3	Outputs	41
15.2.4	Products/Calibration (additional functions)	43
15.3	Read/write parameters	43
15.4	Save/load software configuration	44
16	Calibration	45
16.1	Product selection for calibration	45
16.2	Number of calibration points	46
16.3	Start of calibration	46
16.4	Notes on calibration	48
16.5	Completion of calibration	49
16.6	Determining the optimal filter value	50
16.7	Graphical determination of a calibration point	52
16.8	Offline calibration	52
17	Troubleshooting.....	54
17.1	Software or hardware-related causes of errors	54
17.2	Process-related causes of error	55
18	Disposal.....	55

1 Safety instructions and installation



Note: Installation, operation, and maintenance may only be carried out by qualified personnel.

When installing and operating the device, the applicable safety guidelines (including national safety guidelines), accident prevention regulations, and general technical rules must be observed.



Note: The device's circuits must not be accessed.

Do not repair the device yourself; replace it with an equivalent device. Repairs may only be carried out by the manufacturer.

Safety-related data can be found in the operating instructions or in other certificates (if necessary).

2 Classification of safety instructions

This manual contains information that you must observe for your personal safety and to avoid damage to property. This information is highlighted by a triangular warning sign.



EXPLOSION PROTECTION

Special instructions for devices that may be used in potentially explosive atmospheres.

WARNING



means that death or serious injury may occur if the appropriate precautions are not taken .

CAUTION



with a triangular warning sign means that minor injury or damage to electrical components may occur if the appropriate precautions are not taken .

CAUTION

without a triangular warning sign means that property damage may occur if the appropriate precautions are not taken.

WARNING

means that an undesirable result or condition may occur if the relevant instruction is not followed.

NOTES

indicates important information about the product, how to use the product, or the relevant section of the documentation, is intended to draw particular attention to this information, and must be observed.

In addition to the information in this manual, the generally applicable safety and accident prevention regulations must be observed. If the information contained in this document is not sufficient in individual cases, you can obtain further information from our telephone service. Please read this manual carefully before installation and commissioning.

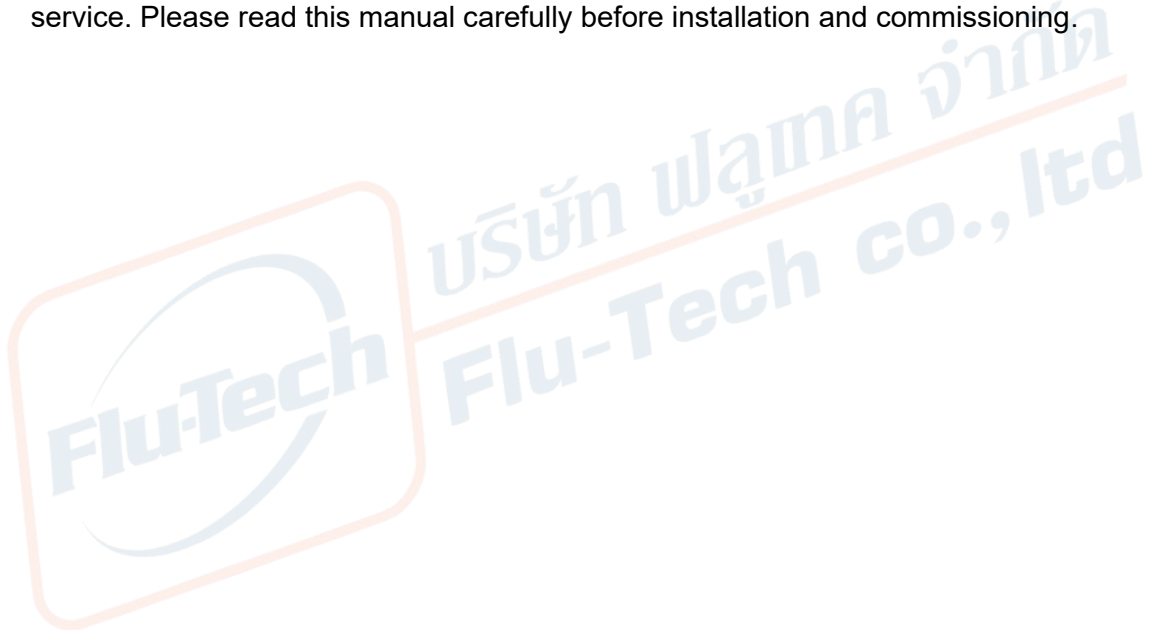

3 General instructions

This device left the factory in a condition that is safe from a technical standpoint. In order to maintain this condition and ensure safe operation of the device, the user must observe the instructions and warnings listed in this operating manual.

For reasons of clarity, the manual does not contain all the detailed information on all product types and therefore cannot take into account every conceivable case with regard to installation, operation, and maintenance .

If you require further information or if specific problems arise that are not covered in sufficient detail in the manual, you can obtain the necessary information by telephone.

We would also like to point out that the content of this manual is not part of any previous or existing contract, agreement, or legal relationship, nor is it intended to modify any such contract, agreement, or legal relationship. All obligations of Mütec Instruments GmbH arise from the respective purchase contract, which also contains the complete and solely valid warranty provisions. These contractual warranty provisions are neither extended nor restricted by the information contained in the manual.

The content corresponds to the current state of printing technology. We reserve the right to make technical changes in the course of further development .

WARNING

The proper and safe operation of this device requires proper transport, professional storage, installation, and assembly, as well as careful operation and maintenance. The device may only be used for the purposes specified in this operating manual.

DISCLAIMER

All modifications to the device are the responsibility of the user, unless expressly stated otherwise in the operating instructions.

VALIDITY

The data sheet is only valid for the MF 3001 described and the hardware/firmware version specified in the technical data.

QUALIFIED PERSONNEL

Qualified personnel are persons who, based on their training, experience, and instruction, as well as their knowledge of relevant standards, regulations, accident prevention regulations, and operating conditions, have been authorized by the person responsible for the safety of the system to carry out the necessary planning and activities and to recognize and avoid potential hazards.

PREREQUISITES

The qualified personnel must have knowledge in the following areas:

- Applicable EMC regulations
- Applicable regulations for occupational safety and accident prevention
- For ATEX-certified devices: experience and training in the planning, installation, and operation of Ex devices

SAFETY INSTRUCTIONS

The safety regulations of electrical engineering and the employers' liability insurance association must be observed and complied with. Failure to observe the safety regulations can result in death, serious injury, or significant property damage.

DIRECT/INDIRECT CONTACT

Protection against direct and indirect contact in accordance with VDE 0100 Part 410 must be ensured for all components connected to the system. In the event of a fault, there must be no dangerous carryover of voltage.

INSTALLATION, COMMISSIONING, MODIFICATION

Installation, commissioning, modification, and retrofitting may only be carried out by qualified personnel. Before starting work, the device must be disconnected from the power supply. The wiring must be carried out and checked in accordance with the intended use.

SWAPPING AND REVERSING THE CONNECTIONS

Take measures to prevent mix-ups, reverse polarity, or tampering with the connections.

DAMAGED DEVICE

The device may be damaged after a fault. Proper and safe operation can then no longer be guaranteed and the device should therefore be replaced. Only the manufacturer or a person authorized by the manufacturer may open the housing and repair the device. Otherwise, any warranty will be void.

DECOMMISSIONING AND DISPOSAL

The device must be disposed of in accordance with environmental regulations. It must be ensured that a defective device cannot be reused.

CE mark, declaration of conformity

The devices are constructed and tested in accordance with the latest technology and have left the factory in a condition that is safe to use. The measuring system described in this operating manual therefore complies with the legal requirements of EU directives. Mütec Instruments confirms the successful testing of the device by affixing the CE mark.

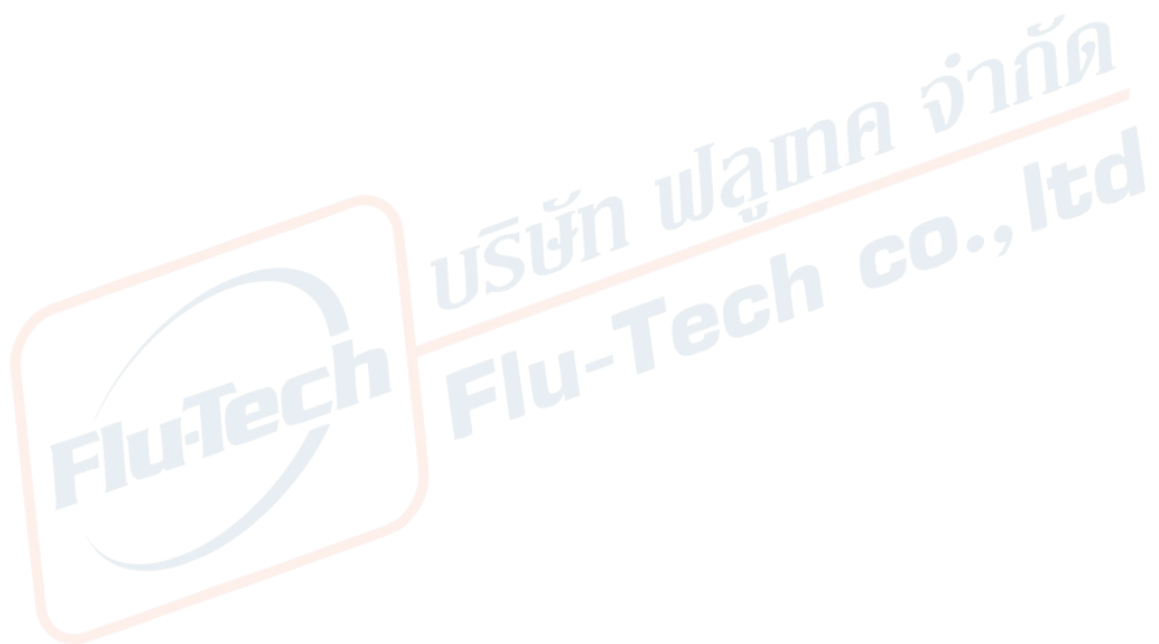

4 Technical data

4.1 Transmitter

General data

Housing

Material:	Polyamide
Protection class:	IP20
Flammability class:	V0 according to UL 94
Dimensions (WxLxH):	22.5 mm x 114.5 mm x 99 mm without terminals
Weight:	250 g
Design:	Terminal housing for mounting rail installation
Mounting/installation position:	Any

Limit values

Permissible temperature:	-10 °C to +60 °C
Storage/transport:	-10 °C ... +70 °C
Permissible humidity during operation:	10% to 95% RH without condensation

Throughput measurement

Measured value:	Several kg/h to approx. 20 t/h
Display:	Percentage value with max. 2 decimal places
Accuracy:	1 - 3%, depending on process and installation situation
Average value:	0-100 seconds
Product memory:	Max. 24 product characteristics

Power supply

(Terminals 3+4, TBUS Terminals B4+B5)

Voltage:	24 VDC (18..30V)
Power consumption:	max. 2.0 W

Analog output (Terminal 1+2)

Output value:	up to 22 mA / 11 V
Accuracy:	40 μ A / 20 mV
Load (mA):	up to 500 ohms
Load (V):	up to 50 kOhm
Rise time:	max. 150 ms
Isolation:	galvanically isolated

Switching outputs

Relay output (Terminals 9+10)

Contact:	NO (normally open)
Switching voltage:	30 V, AC/DC
Switching current:	1 A, DC / 0.3 A, AC
Switching capacity:	30 W / 9 VA, AC

Transistor output (Terminals 11+12)

Technology:	Open collector
Switching voltage:	28 V
Switching current:	50mA
Separation:	galvanically isolated

Switching inputs (Terminals 13-20)

Number:	4
Technology:	Optocoupler
Max. control voltage:	28 VDC
Low / inactive	< 5 VDC
High / active	> 15 VDC
Isolation:	galvanically isolated

Data interfaces

USB interface

Technology:	USB 2.0, mini USB
Speed:	Up to 115200 baud
Isolation:	galvanically isolated

RS485 interface

(Terminals 5-7, TBUS Terminals B1-B3)

Speed:	up to 115200 baud
Termination:	Software-controlled
Biasing:	None
Isolation:	Galvanically isolated

Sensor power supply

(Terminals 23+24)

Voltage:	20 V, DC
Supply capacity:	100 mA
Current limitation:	Functional supply current limitation (PTC or transistor)
Isolation:	Galvanically isolated

Data connection sensor (Terminals 21+22)

Interface:	RS485
Termination:	470R
Biasing:	1k0 against 0 and 5 V
Isolation:	galvanically isolated
Baud rate	Max. 115200 bps

4.2 Sensor

General data

Housing:

Material	Stainless steel 1.4307 or 1.4571 PA6.6 GF30 (MFS3000-K), PTFE (MFS3000-T), Ceramic (MFS3000-C)
Protection class:	IP 65 according to EN 60529
Process connection	Welded connection
Weight	Approx. 1300 g
Connection cable:	Shielded cable, 4-wire, min. 0.5 mm ²
Cable length:	max. 500 m

Limit values (non-ATEX)

Process pressure:	max. 6 bar, temporarily 30 bar (MFS3000-K/T) max. 2 bar (MFS3000-C with HT150) max. 1 bar (MFS3000-C with HT450)
Ambient temperature:	-10°C to +70°C
Process temperature:	-20 to +90°C (MFS3000-K) -20 to +120°C (MFS3000-T) -20 to +150°C (MFS3000-C with HT150) -20 to +450°C (MFS3000-C with HT450)
Storage temperature:	-10 to 80°C

Limit values (ATEX)



Process pressure:	0.8 to 1.1 bar (MFS3000-K/T Ex)
Ambient temperature:	-10°C to +65°C
Process temperature:	-20 to +80°C (MFS3000-K-ExD and MFS3000-K-ExG) -20 to +100°C (MFS3000-T-ExD)
Surface temperature:	Max. 135°C (MFS3000-K-ExD and MFS3000-T-ExD)

5 Dimensions

5.1 Transmitter

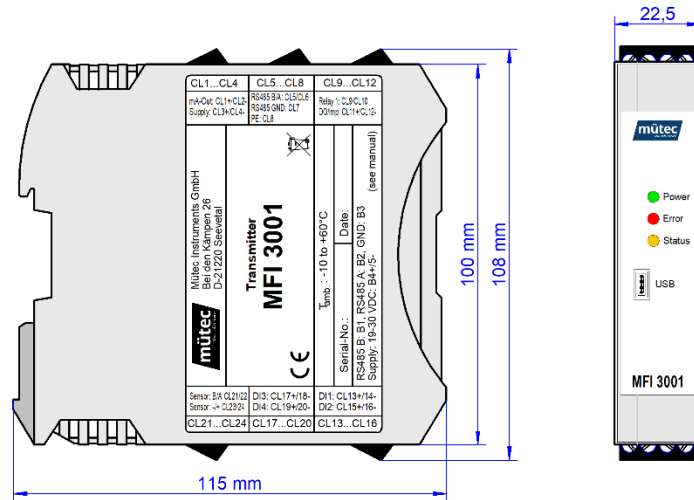

5.2 Sensor

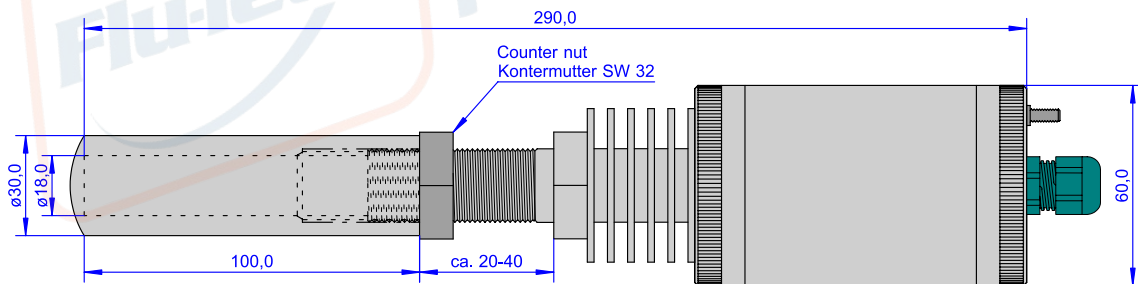

6 Intended use

The massflow measurement system consists of the **MFI 3001** control and evaluation unit in a DIN rail housing and the **MFS 3000/3001** mass flow measurement probe. The inline measuring system for process monitoring guarantees trouble-free measurement of the mass flow rate of solids and powders. A PC-based user interface with a clear display of the measurement, alarm, and MIN/MAX values, combined with simple editing and parameterization, enables uncomplicated and easy operation.

The sensor can be used in free fall and in pneumatic pipelines (vertical or horizontal). It must be mounted flush with the pipeline. The pipeline must be metallic and have a maximum diameter of $D=300\text{mm}$.

Even distribution of the product in the pipe is essential for accurate measurement. In pneumatically conveyed pipes, measurement is only possible in dilute phase at a constant transport speed.

The bulk density and dielectric properties of the material must be constant. Calibration curves for up to 24 different products can be stored in the transmitter.

Calibration is performed during the running process and with at least two points (maximum mass throughput and no mass throughput), preferably with up to 5 points.

7 Measuring principle

The MFS 3000 sensor for mass throughput measurement works on the microwave principle. The microwave is emitted from the MFS3000, which is installed flush with the inner wall of the pipe, into the metallic pipe, which acts as a measuring chamber. The emitted wave fronts encounter the passing solid particles and cause a frequency shift (Doppler effect) of the reflected signal. The intermediate frequency signals, whose frequency and amplitude are proportional to the velocity and size of the solid particles, are recorded as measured values and form the basis for calculating the amount of solids. Particles at rest as deposits on the pipe wall are not included in the measurement.

8 Sensor design

The MF3000 system consists of a cylindrical mass flow sensor with weld-on connection, a DIN rail transmitter, and the MFConfig PC software. The process connection is made via a weld-on connection into which the mass flow sensor is screwed flush with the inner wall of the pipe. The sensor is connected to the transmitter via a 4-wire cable. The transmitter is equipped with an analog, alarm relay, and transistor output, as well as a USB and RS485 interface and 4 digital inputs.

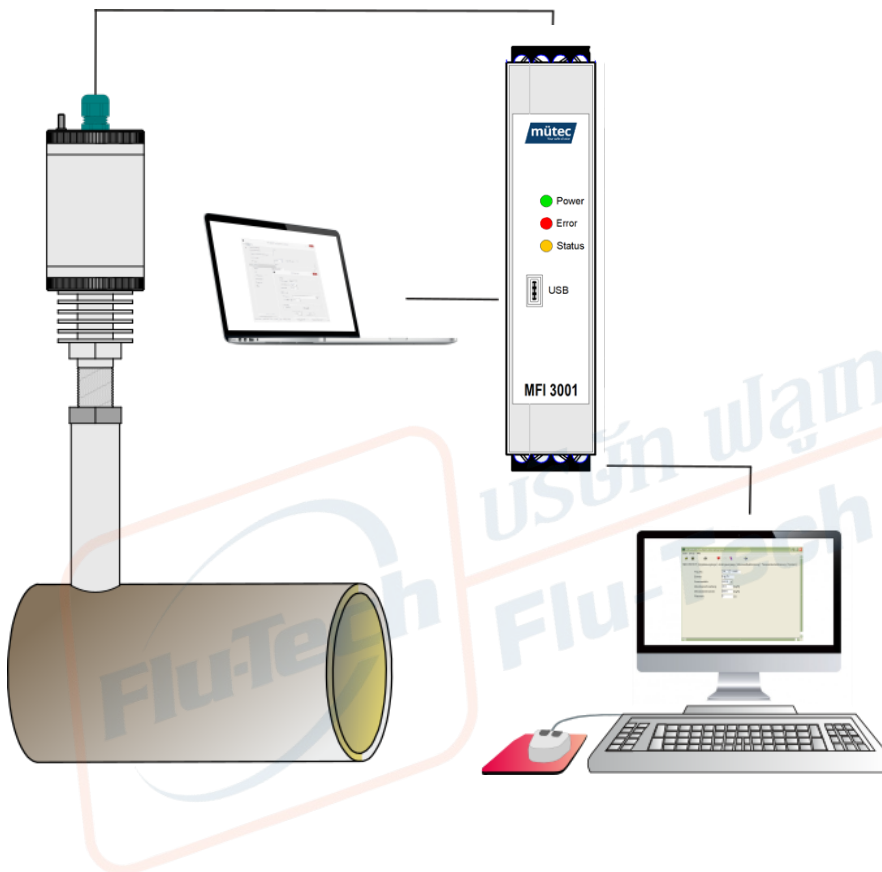

Housed in a stainless steel enclosure, the measuring sensor is connected to the MFI3001 transmitter via a 4-wire connection and can be parameterized and calibrated online via the RS485 interface. The raw measurement value for the solids content is transmitted to the transmitter for evaluation. The solids content is available as a standardized 0/4-20 mA or 0/2-10 V signal at the analog output or as digital information via the RS485 connection. A configurable relay contact output and a transistor output are available for max/min alarms. The digital inputs can be used to switch between up to 16 calibration curves.

After parameterization and calibration of the MFS3000, the measured value can be observed or documented in the MFConfig software interface.

9 Installation

9.1 Transmitter installation

The ME-MAX housing can be combined with a 5-pin TBUS connector/mounting rail connector. The RS485 interface and the supply voltage can be conveniently wired through the TBUS connector snapped into the top-hat rail. The TBUS connection is self-assembling in the grid of the devices involved. This eliminates the need for time-consuming preliminary planning or reworking of the TBUS connection on site.

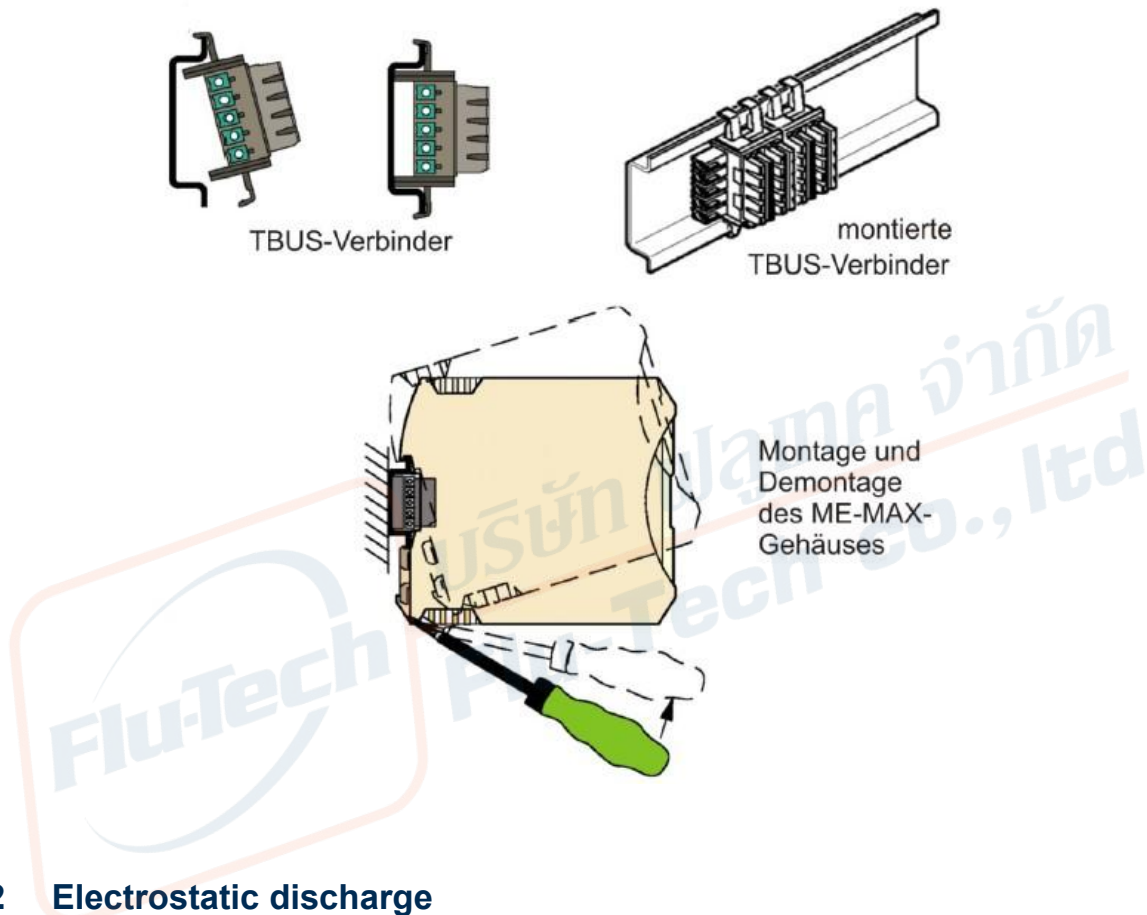

9.2 Electrostatic discharge

Electrostatically sensitive components can be destroyed by voltages that are far below the human perception threshold. These voltages occur when a component or electrical connections of a module are touched without being electrostatically discharged. The damage caused by overvoltage to a module is usually not immediately apparent, but only becomes noticeable after prolonged operation. The device contains components that can be damaged or destroyed by electrostatic discharge. When handling the device, observe the necessary protective measures against electrostatic discharge (ESD) in accordance with EN 61340-5-1 and EN 61340-5-2.



9.3 Mounting the sensor

9.3.1 Preparations for sensor installation

A welding machine and a drill (drill bit = 18 mm \varnothing) are required for installation. Several important points should be considered when selecting the optimal installation location. In general, the weld-on connection can be installed in a horizontal transport line or in a vertical free-fall line, but installation in a free-fall line is always preferable. For air transport lines, vertical line routing with transport from bottom to top is preferable.

The inlet and outlet sections to the MFS3000/3001 specified below as a multiple of the nominal diameter (DN) should not be undershot:

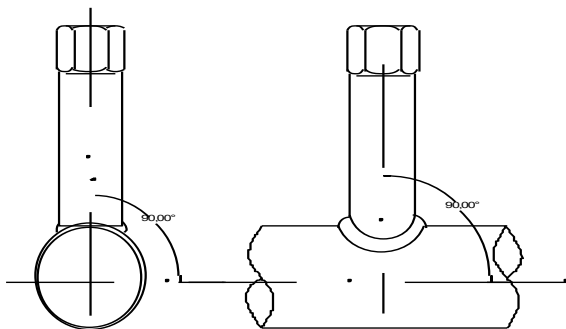
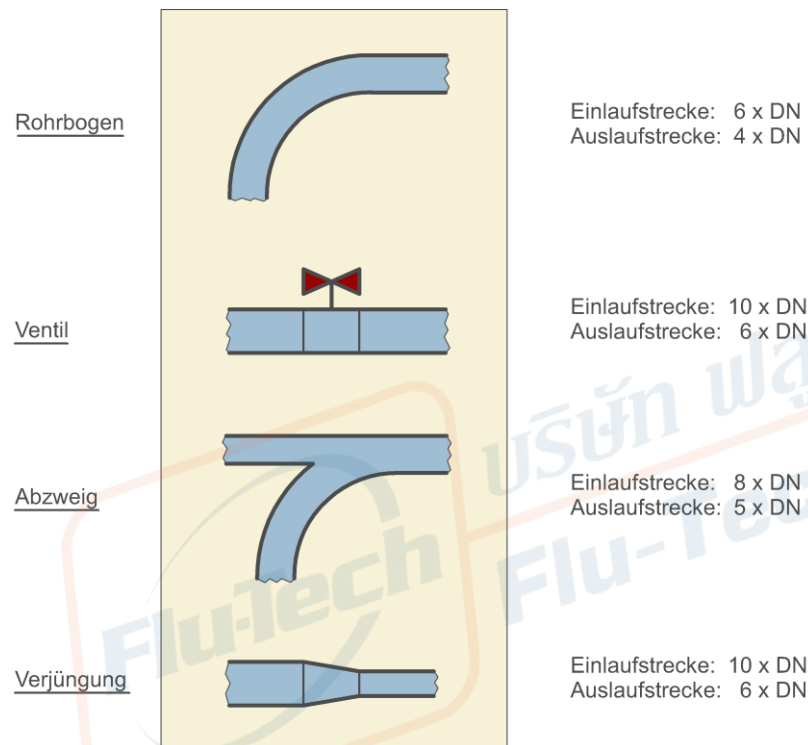

After fixing the mass flow sensor nozzle vertically and at a 90° angle to the pipe axis, the weld seam to be applied must securely close the gap between the nozzle and the pipe wall.

The quality of the weld seam can be checked with a subsequent pressure test. The pipe wall is drilled out for the required measuring window using an 18 mm drill bit, with the previously welded nozzle serving as a drilling template. After drilling, the drill hole on the inner pipe wall must be deburred as thoroughly as possible to prevent material deposits. On a vertical pipe, the connection piece is placed horizontally and also at a 90° angle to the pipe axis.

9.3.2 Installation of the sensor

Before screwing the mass flow sensor into the connection piece, the total depth is determined from the length of the connection piece and the wall thickness of the pipe and marked on the shaft of the mass flow sensor. The measuring window should be flush with the inner wall of the pipe so that it does not protrude into the pipe. Screw the mass flow sensor into the connection up to the marked line. Teflon tape is recommended for a better seal. The polarization axis marked on the type plate is then aligned with the pipe axis. Tightening the lock nut (SW32) on the threaded shaft firmly secures the mass flow sensor in the connection piece.

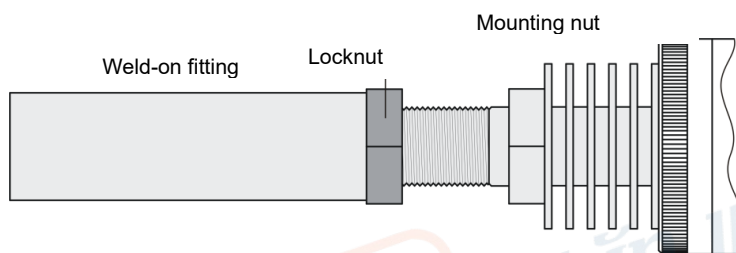

The sensor may only be screwed into the weld-on connection and locked in place using the mounting nut (SW 32) located on the housing.

9.3.3 Electrical connection and wiring

The MFI3001 DIN rail transmitter should always be installed in a control cabinet or dry room and must be supplied with 24V DC. The electrical connection between the mass flow sensor and the transmitter must be made using a shielded 4-wire cable. For cable lengths up to 60 m, a cable cross-section of 0.5 mm² is sufficient; for longer lengths, a cross-section of ≥ 1.0 mm² is required in proportion to the cable length (500 m). A single-shielded cable is used as standard.



NOTE

A PE connection (M4 threaded bolt) is provided on the mass flow sensor housing for easy grounding.



The mass flow sensor must not be opened while under voltage!

For the device to function correctly, the housing must be grounded!

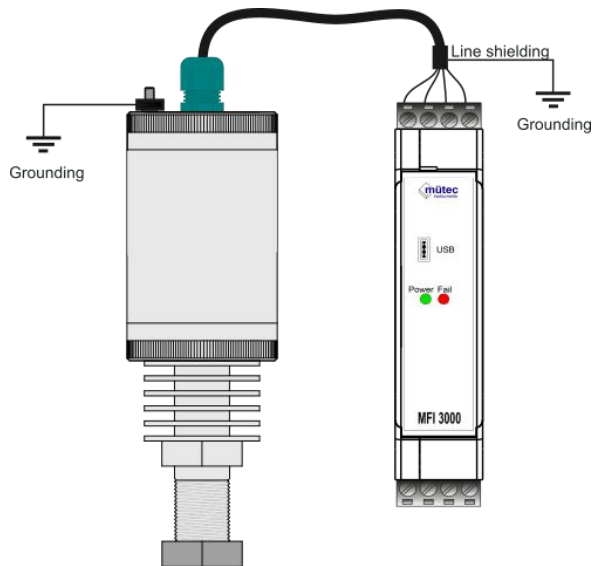

To prevent potential equalization currents from flowing through the cable shield, it may only be grounded at one end of the cable. For practical reasons, the cable shield should always be grounded on the transmitter side. The cable sheath and cable shield must be removed for wiring on the mass flow sensor. A piece of heat-shrink tubing pushed over the cable end ensures sufficient insulation of the cable shield to the cable gland or housing, thus preventing unwanted ground contact.

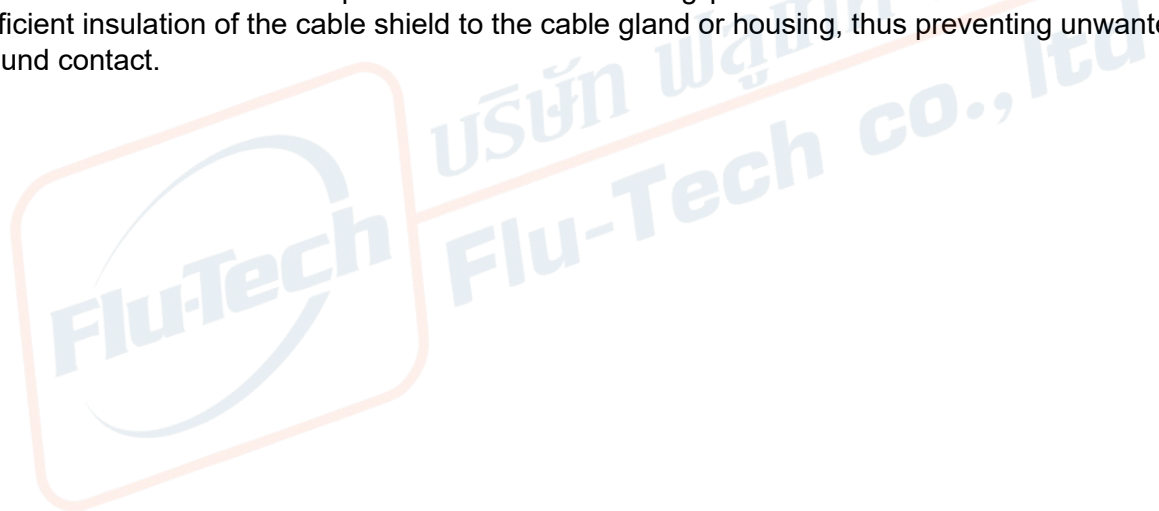

10 Electrical connection

10.1 Transmitter terminal assignment

Terminal 1	mA out (+)	Terminal 13	DI 1 (+)
Terminal 2	mA out (-)	Terminal 14	DI 1 (-)
Terminal 3	Supply (+)	Terminal 15	DI 2 (+)
Terminal 4	Supply (-)	Terminal 16	DI 2 (-)
Terminal 5	RS 485 (B)	Terminal 17	DI 3 (+)
Terminal 6	RS 485 (A)	Terminal 18	DI 3 (-)
Terminal 7	RS 485 (GND)	Terminal 19	DI 4 (+)
Terminal 8	PE	Terminal 20	DI 4 (-)
Terminal 9	Relay 1	Terminal 21	Sensor B
Terminal 10	Relay 1	Terminal 22	Sensor A
Terminal 11	DO / Imp (+)	Terminal 23	Sensor (-)
Terminal 12	DO / Imp (-)	Terminal 24	Sensor (+)

10.2 Terminal block assignment

Terminal B1	RS 485 B
Terminal B2	RS 485 A
Terminal B3	RS 485 GND
Terminal B4	Power supply (+)
Terminal B5	Power supply (-)

Sensor

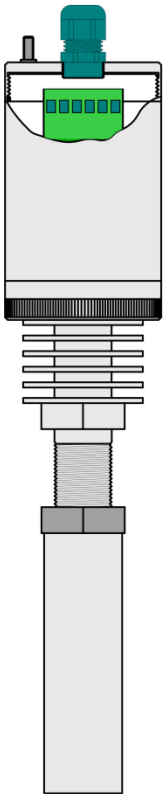

- K11: Brown (RS485b)
- K12: Orange (RS485a)
- K13: Black (-)
- K14: Red (+)



The cable shield is connected to the ground contact in the probe. If the cable shield is also grounded at the other end of the cable and there is a significant potential difference between the two grounding points, a considerable equalizing current flow may result via the cable shield.



Risk of electric shock! Do not install or wire the device while it is connected to the mains. Failure to do so may also result in damage to parts of the electronics. The device is grounded via the grounding screw on the housing (minimum 4 mm). Before wiring, make sure that the device is grounded! Compare the information on the label with the available supply voltage. Observe the nationally applicable installation regulations.

10.3 Cable installation



The sensor is supplied with a 3 m connection cable as standard. The connection cable must be securely installed for safe operation of the sensor, e.g., in a cable duct.

11 Commissioning

11.1 Switching on the measuring system



1. Ensure that all cable connections are correct.
2. Apply operating voltage.
3. Operational readiness is indicated by the green POWER LED on the front panel of the MFI3001 transmitter.

12 Notes for operation in potentially explosive atmospheres



Only devices of the **MFS3000-K/T-ExD** and **MFS3000-K-ExG** types (see type label) may be used in Zone 20/21 or 2.

Devices of the **MFS3000-K/T-ExD** type (see type label) may be used in ATEX Zone 20 in the conveyor pipe and in ATEX Zone 21 in the surrounding area.

"Explosion protection!" indicates activities or processes which, if not carried out properly, can lead to personal injury, a safety risk, and the loss of approval! Follow the work instructions carefully and proceed with caution.

Before use, you must check whether the detailed approval of the device (Ex marking on the type plate) is correct for the intended area of application.

12.1 Marking according to Directive 2014/34/EU:

Mass flow sensor MFS3000-K/T-ExD:

EU type examination certificate: KIWA 20ATEX0029 X

Compliance with: EN IEC 60079-0:2018 (General requirements)
EN 60079-31:2014 (Protection by enclosure "t")









Mass flow sensor MFS3000-K-ExG:

EU type examination certificate: KIWA 20ATEX0030

Conformity with: EN IEC 60079-0:2018 (General requirements)
EN 60079-7:2015+A1:2018 (Increased safety "e")

Category	Explosive atmosphere	Type of protection	Type
II 1/2D	Dust	Ex ta/tb IIIC T135°C Da/Db	MFS3000-K/T
II 3G	Gas	Ex ec IIC T4 Gc	MFS3000-K-ExG

12.2 Marking of sensors

 Mütec Instruments GmbH Bei den Kämpfen 26 D-21220 Seevetal		 Mütec Instruments GmbH Bei den Kämpfen 26 D-21220 Seevetal		 Mütec Instruments GmbH Bei den Kämpfen 26 D-21220 Seevetal	
MFS 3000-K-ExD V2A (ST304)		MFS 3000-T-ExD V2A (ST304)		MFS 3000-K-ExG V2A (ST304)	
II 1/2D Ex ta/tb IIIC T135°C Da/Db  KIWA 20ATEX0029 X Warnung / Warning Gefahr durch elektrostatische Entladung! Danger from electrostatic discharge! Siehe Betriebsanleitung / See manual		II 1/2D Ex ta/tb IIIC T135°C Da/Db  KIWA 20ATEX0029 X Warnung / Warning Gefahr durch elektrostatische Entladung! Danger from electrostatic discharge! Siehe Betriebsanleitung / See manual		II 3G Ex ec IIC T4 Gc  KIWA 20ATEX0030 	
Temp. amb.: -10 ... +65°C Temp. proc.: -20 ... +80°C Pmax.: 1,0 bar Serial No.: 2551 / 0264  0158		Temp. amb.: -10 ... +65°C Temp. proc.: -20 ... +100°C Pmax.: 1,0 bar Serial No.: 2551 / 0264  0158		Temp. amb.: -10 ... +65°C Temp. proc.: -20 ... +80°C Pmax.: 1,0 bar Serial No.: 2551 / 0264	
Zum Anschluss an den Transmitter MFI 3001 For connection to the transmitter MFI 3001 T 1 = RS 485 (B) [brown] T 2 = RS 485 (A) [orange] T 3 = Power (-) [black] T 4 = Power (+) [red] Achtung / Attention Sensorkopf nicht im Materialfluss montieren! Don't mount sensor head into the material flow!		Zum Anschluss an den Transmitter MFI 3001 For connection to the transmitter MFI 3001 T 1 = RS 485 (B) [brown] T 2 = RS 485 (A) [orange] T 3 = Power (-) [black] T 4 = Power (+) [red] Achtung / Attention Sensorkopf nicht im Materialfluss montieren! Don't mount sensor head into the material flow!		Zum Anschluss an den Transmitter MFI 3001 For connection to the transmitter MFI 3001 T 1 = RS 485 (B) [brown] T 2 = RS 485 (A) [orange] T 3 = Power (-) [black] T 4 = Power (+) [red] Achtung / Attention Sensorkopf nicht im Materialfluss montieren! Don't mount sensor head into the material flow!	
Contains FCC ID: UXS-SMR3X3 Polarisation		Polarisation		Polarisation	

12.3 Safety instructions

The interface or sensor must be taken out of service and secured against unintentional operation if it must be assumed that safe operation is no longer possible. Reasons for this assumption may include:

- Visible damage to the device
- Failure of the electrical function
- Prolonged storage at temperatures above 85 °C
- heavy transport stress

Before the device is put back into operation, a professional unit test must be carried out in accordance with DIN EN 61010, Part 1. This test must be carried out by the manufacturer. Repair work on Ex devices may only be carried out in accordance with BetrSichV, Appendix 2, Section 3 (in its entirety, but especially points 3 and 4).

The sensor housing may only be opened in a non-explosive atmosphere and with the power supply disconnected.

12.4 Installation in ATEX Zone 20/21 or Zone 2

Sensors with the ATEX marking "Ex ta/tb" (protection by enclosure) and "Ex ec" (increased safety) can be connected directly to the MFI3001 transmitter. The transmitter must be installed **outside** the Ex area.



Explosive atmosphere:
Sensor **MFS3000-K/T-ExD**,
MFS3000-K-ExG

Non-Ex area:
MFI3001 transmitter



12.5 Further information on sensor installation

- Assembly/disassembly, installation, operation, and maintenance may only be carried out by qualified personnel in accordance with the automation industry, observing the relevant regulations and these operating instructions. The regulations according to EN 60079-14 must be observed.
- The relevant regulations of the country of installation must be observed during installation and connection.
- The permissible ambient and process temperature and the maximum permissible process pressure for the sensor must be observed. These must not exceed the ranges specified in the technical data.
- If the housing is damaged, e.g., by a mechanical impact, the sensor may no longer be used in hazardous areas. The device must be sent in for inspection.
- The measuring aperture of the sensor must be protected from UV radiation.
- For safe operation of **the MFS3000-x-Exx**, **it is essential** that **it is** permanently connected to the equipotential bonding via a protective conductor connection to the marked 4 mm threaded bolt on the cover of the sensor housing. The solid screw connection allows the connection of cable cross-sections up to a maximum of 4 mm² using a suitable cable lug.

12.6 Troubleshooting and repair

No modifications may be made to devices that are operated in connection with potentially explosive areas. Repairs to the device may only be carried out by specially trained and authorized personnel.

Repairs that could impair the type of protection must only be carried out by Mütec.

13 Introduction to the MFconfig software

The **MFconfig** configuration software is installed on a Windows PC (Windows 7, 10, 11) and is used to calibrate and parameterize the **MF 3001** inline throughput measurement system and for graphical analysis of the process. The measured values are stored on the hard drive of the connected PC or laptop and can be retrieved later, e.g., for offline calibration.

The software can manage up to 8 MF 3001 measuring systems. Switching between the products pre-calibrated using the software is done later via the digital inputs of the transmitter (e.g., with a binary-coded switch) or via Modbus RTU command via a connected PLC.

In order to make settings in the MFI 3001 transmitter, all electrical connections must be in place.

Before starting the **MFconfig** program, the transmitter is connected to a PC via the front USB interface.

14 Installation and configuration of the software

The setup wizard for installing the software on your laptop/PC is started with the file "*MF3001_Configuration_Setup_vx.x.x.exe*". After selecting the installation directory, you have the option of automatically installing the driver for the USB connection (only necessary if no connection to a Mütec transmitter has been established yet).

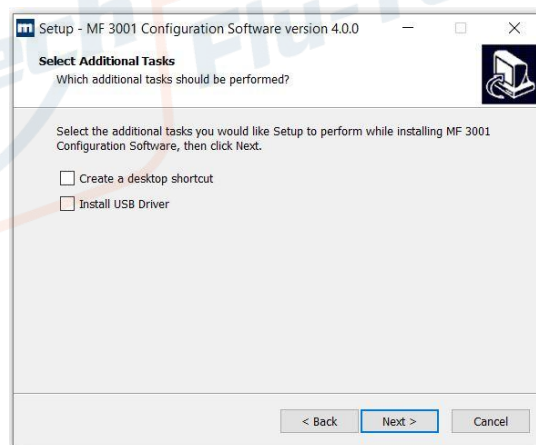

The software starts automatically after the setup wizard has finished, or can be opened manually in the selected installation directory by double-clicking on the file "*MFCConfig.exe*".

14.1 The start screen

After starting the software, the connected measurement systems (left) and the configuration menu (right) are displayed with the last edited configuration folder.

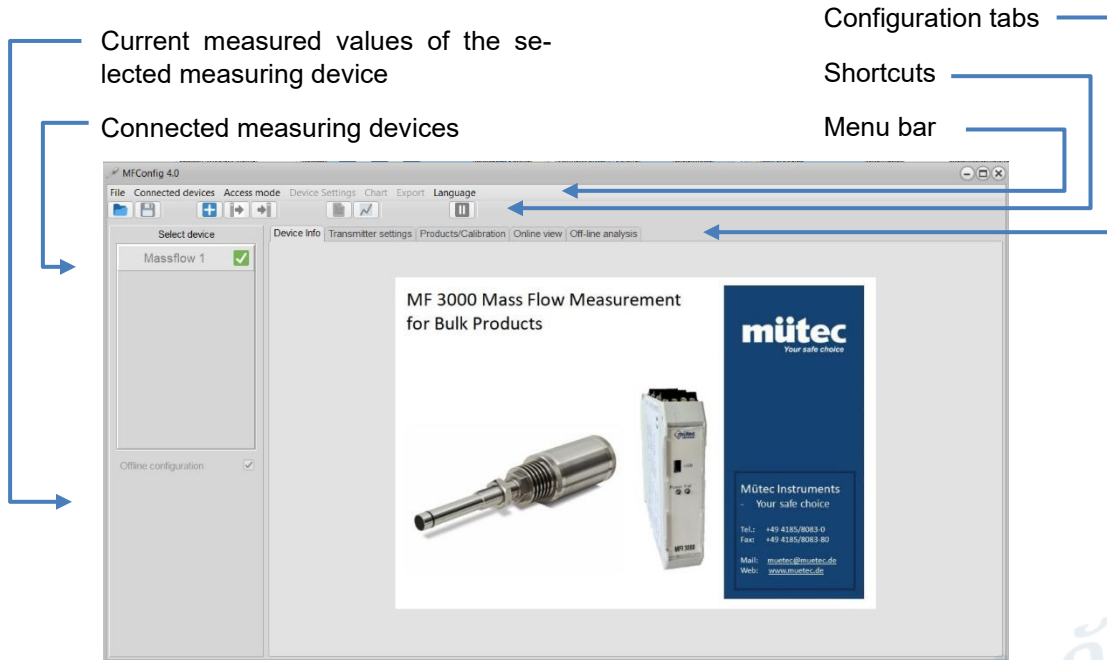

14.2 Language selection

Available languages can be selected in the "Language" menu item.

14.3 Selecting the access mode

The software generally offers two different modes:

1. Standard mode (for all essential basic settings)
2. Expert mode (for experienced users)

These can be selected via the "Access mode" menu.

The software always starts in standard mode.

14.4 Connecting the MFI 3001 transmitter to a PC

A physical connection to the laptop/PC is required to configure the transmitter. Once the transmitter is successfully connected, a virtual COM port is created in the Windows Device Manager. If this is not the case, please install the supplied USB driver manually. You will find the driver in the selected installation directory in the DRIVER folder.

Up to 8 MF 3001 devices can be displayed and configured using the software. A USB hub can be used when connecting multiple MFI 3001 transmitters.

Add the new measuring system in the menu bar via "Device Management" ► "Add New Device," by right-clicking in the "Select Device" field, or by clicking the icon .

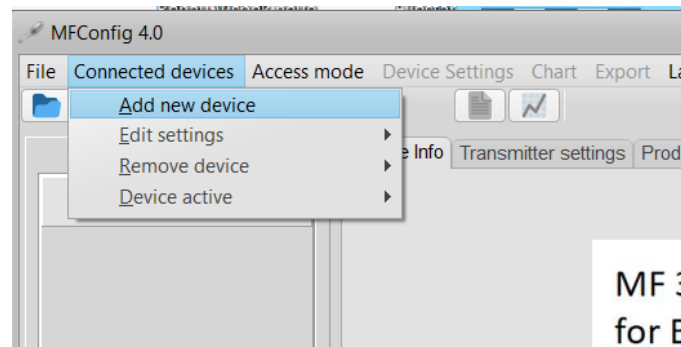

A window will appear for configuring the measurement system and the COM port:

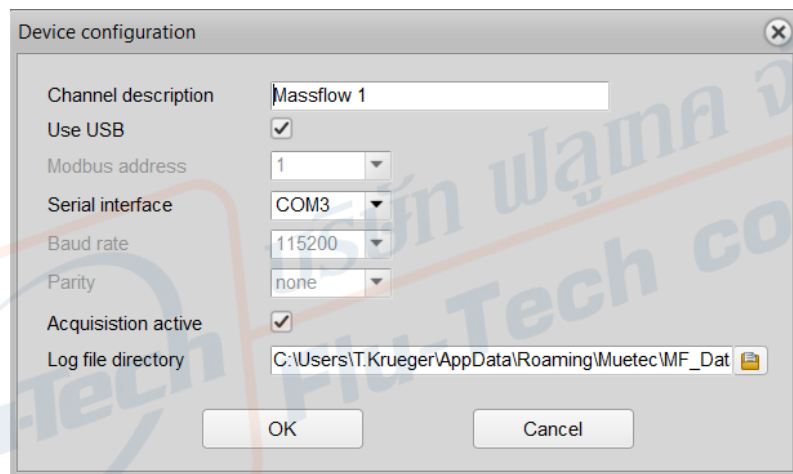

- Channel description: Name of the measuring point (freely configurable)
- Use USB: Activate this field if the transmitter is connected via USB. The baud rate is then automatically set to 115 k baud. Alternatively, communication can also take place via the additional RS485 interface (connection terminals CL5 ... CL7 or top-hat rail terminals B1 ... B3).
- Serial interface: COM port of the transmitter (connected COM ports are automatically detected by the software)
- Data acquisition active: Activation of data retrieval from the transmitter to the PC
- Log file directory: Selection of the Windows directory for storing the measured values

The settings and the selection of the directory for data storage can be changed in the menu via 'Device management' ► 'Edit settings' ► 'Device name':

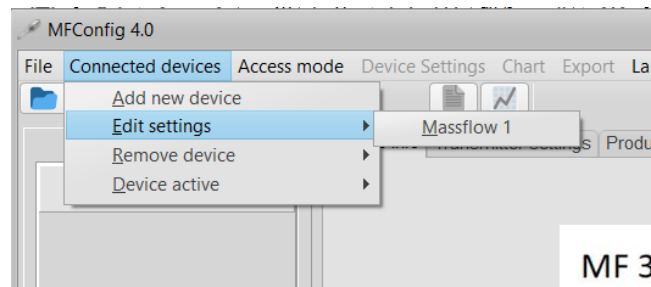

When the connection to the transmitter is successful, a green check mark is displayed next to the device will appear next to the device.

14.5 Selecting and activating the MFI 3001 transmitter

To configure and calibrate the device, click on it to load the parameters. The status field displays the current measured values (raw value, scaled mass flow rate, sensor temperature) and the status of the transmitter.

The parameters can be locked by clicking on the "Offline configuration" checkbox to prevent possible incorrect parameterization of the active device:

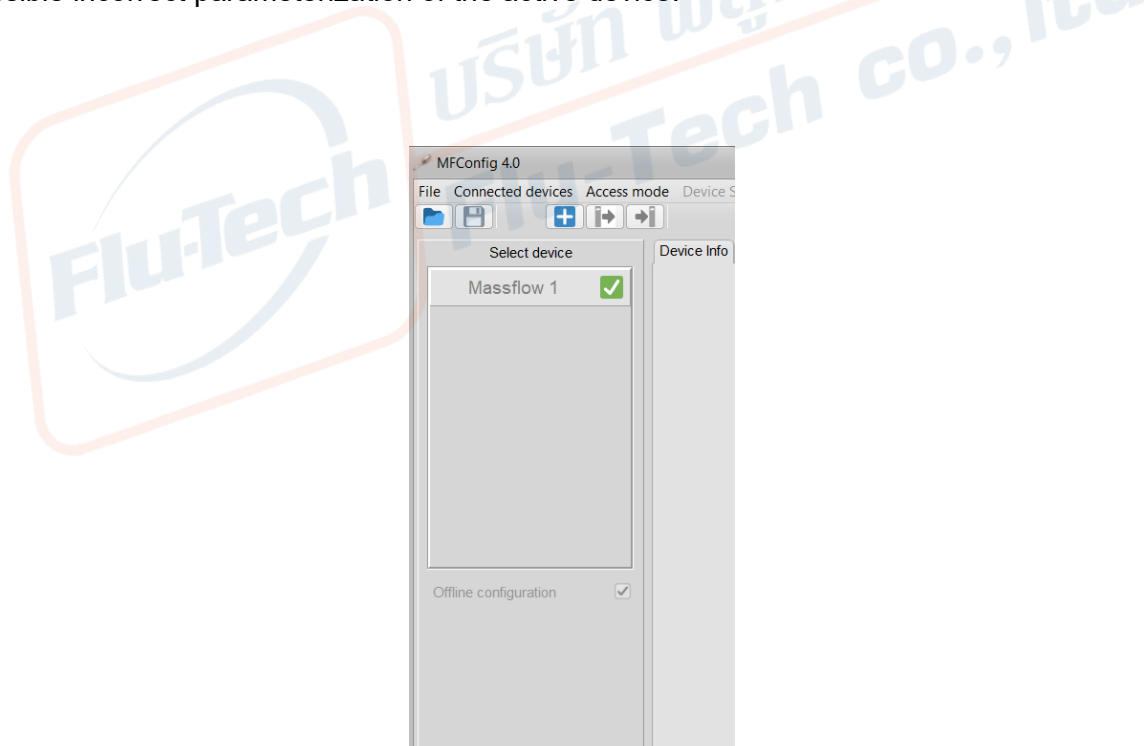

In 'Offline configuration mode, the connection to the transmitter remains active and the measurement data continues to be recorded.

14.6 Deactivate transmitter

To reduce the data rate when multiple transmitters are connected, the connection can be disconnected via the menu item 'Device management' ► 'Active device' ► 'Device name' or by right-clicking on the device:

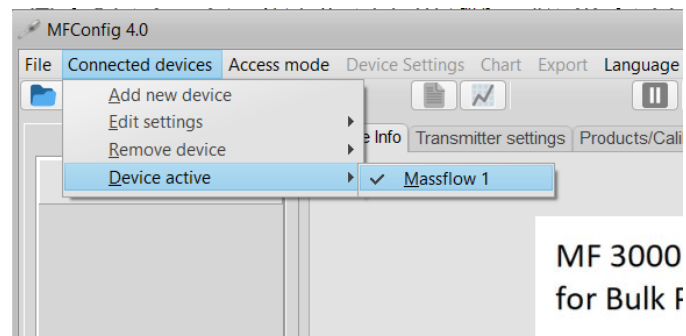

A deactivated device is symbolized by a red circle, and data recording for the device is interrupted:

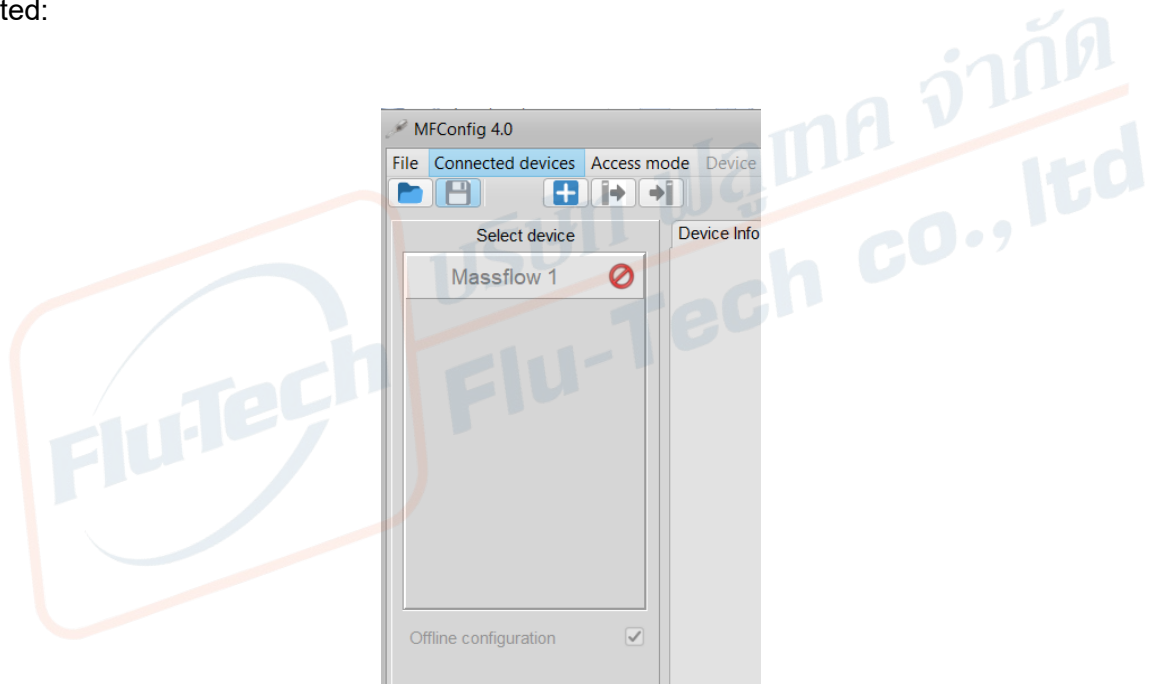

14.7 Remove device

A measurement system can be removed from the workspace via the menu bar or by right-clicking on the device to be deleted:

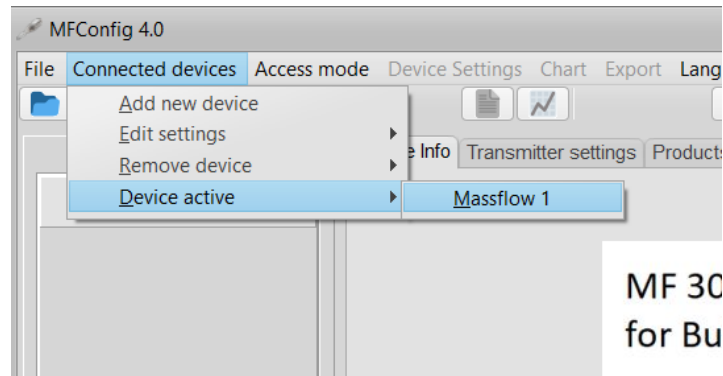

15 Parameterization of the measurement system

15.1 Parameterization in standard mode

The basic settings of the throughput measurement system can be configured in standard mode. Standard mode is set via the "Access mode" ► "User" menu. Parameterization and calibration are performed via the configuration tabs.



Changes to the parameters only take effect when the parameter set is written to the transmitter using the 'Device settings' ► 'Write configuration' command.

15.1.1 Transmitter settings

The basic settings of the transmitter are made in this menu item.

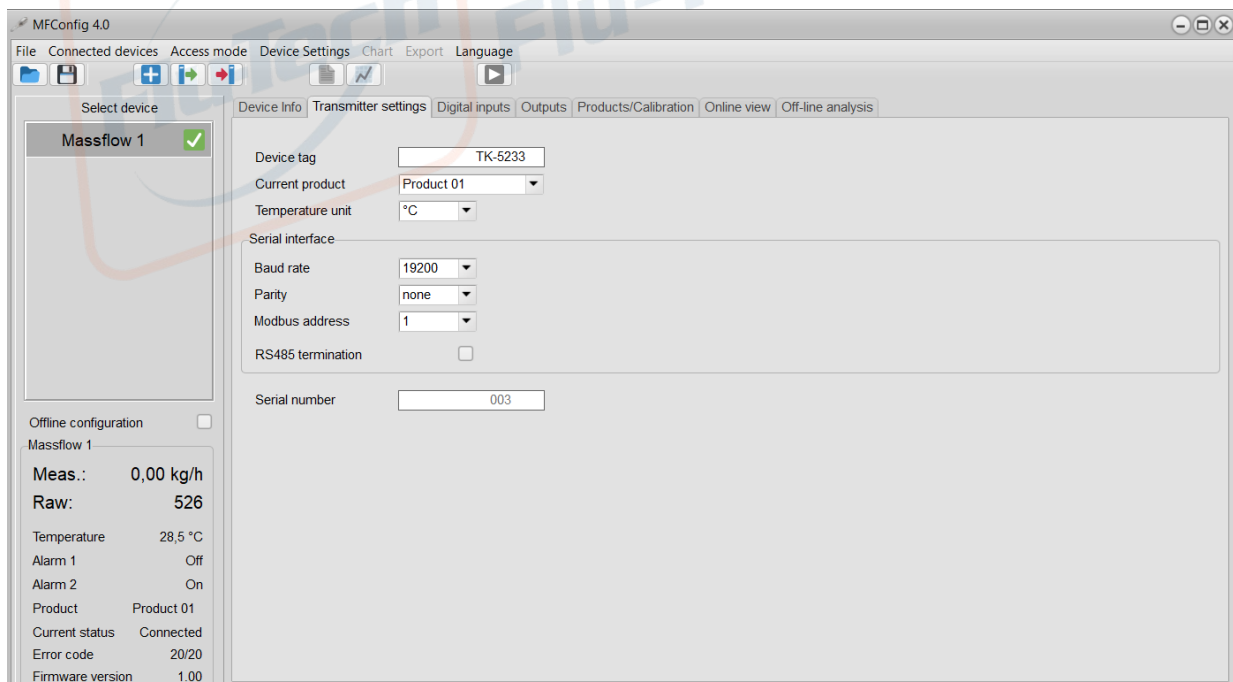

Device tag: Name of the measuring point (freely configurable)

Current product: Selection of the current product whose calibration values are to be used (24 products can be stored)

Temperature unit: Temperature display in °C or °F

Serial number: Serial number of the transmitter (assigned at the factory)

15.1.2 Products/Calibration

Menu for configuring product-specific parameters and calibrating products. Up to 24 different products can be stored.

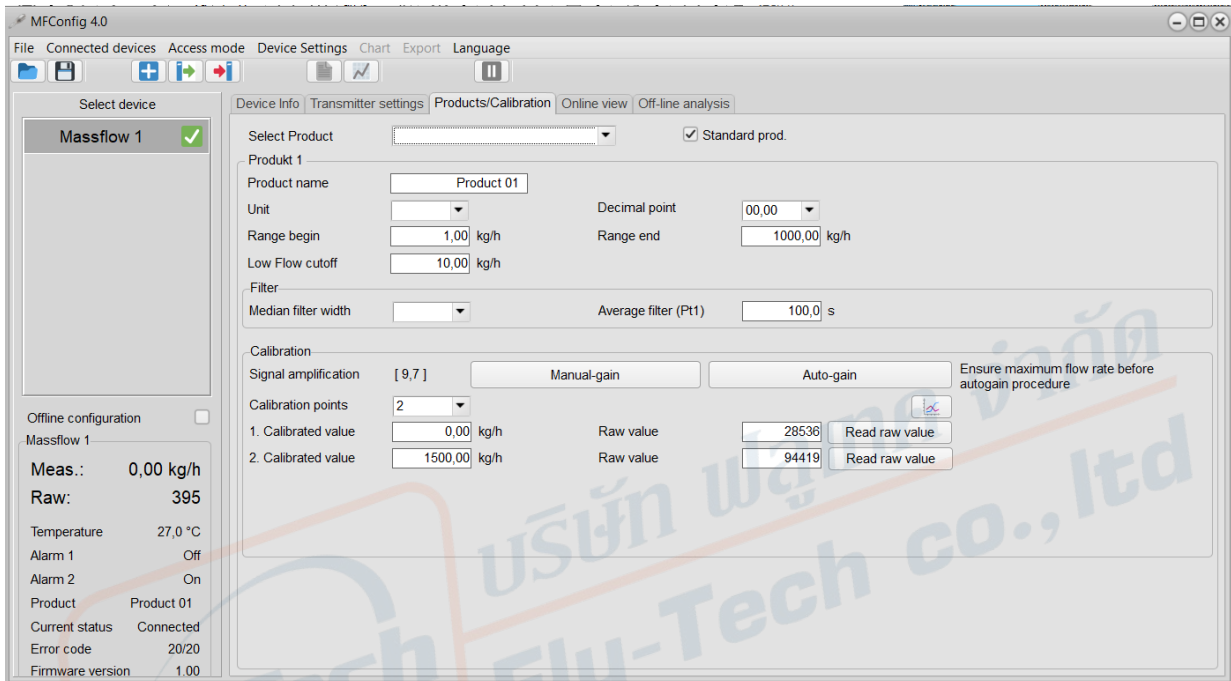

Select product: Select the product whose parameters or configuration are to be changed.
If the "Current product" checkbox is selected, all changes apply to the product currently in use, i.e., the data has an immediate effect on the mass flow values displayed after being uploaded to the transmitter.
If the "Current product" checkbox is not selected, other products in the database can be adjusted "offline."

Product name: Definition of product name (freely configurable)

Unit: Unit of the output value (kg/h, kg/min, kg/s, t/h, lb/h, lb/min, or %)

Decimal point: Decimal place for the displayed digital value

Range start: Scaling of the analog output to increase the resolution. The specified start value corresponds to the analog output value 4mA

Range end: End value of the analog output measuring range. The specified end value corresponds to the analog output value 20mA

Low flow cutoff: Suppresses noise and small measured values that are not to be taken into account for the measurement

Filter:

Median filter: Sorting of measured values by size in a defined measurement window (3-11 measured values)

Average filter: Moving average filter (0-100 seconds).

Worm filter: Suppression of periodically occurring interference signals

Auto gain: Automatic gain adjustment of the measurement signal adapted to the maximum mass flow rate (see Chapter 16 "Calibration")

Manual

amplification: Manual gain adjustment of the measurement signal (see Chapter 16 "Calibration")

Calibration points: Number of measurement points for the calibration curve of a product (2-5 points). At least two measurement points must be used.

Calibrated value: Input of the determined mass throughput, e.g., in kg/h or t/h

Raw value: Raw measurement value of the sensor during calibration

Record raw value: This integrates the current raw value over the calibration time and calculates and enters the mean value

The calibration of the measuring system is described in Chapter 16.

15.1.3 Online view

Up to 8 measured values from different MFI 3001 transmitters can be displayed simultaneously in the online display. The following measured values can be selected for the online display:

Scaled value: Mass flow rate of the selected product (calculated according to the stored calibration curve)

Raw value: Unfiltered raw value of the sensor in digits

Temperature: Current temperature in the sensor's electronics housing

Din1 ... Din4: Status of the digital inputs (e.g., external trigger signals)

The display area can be freely configured using the following control elements:

Manual scaling of the Y-axes

Cursor for analyzing a data range

Start/stop of diagram recording (e.g., for data analysis)

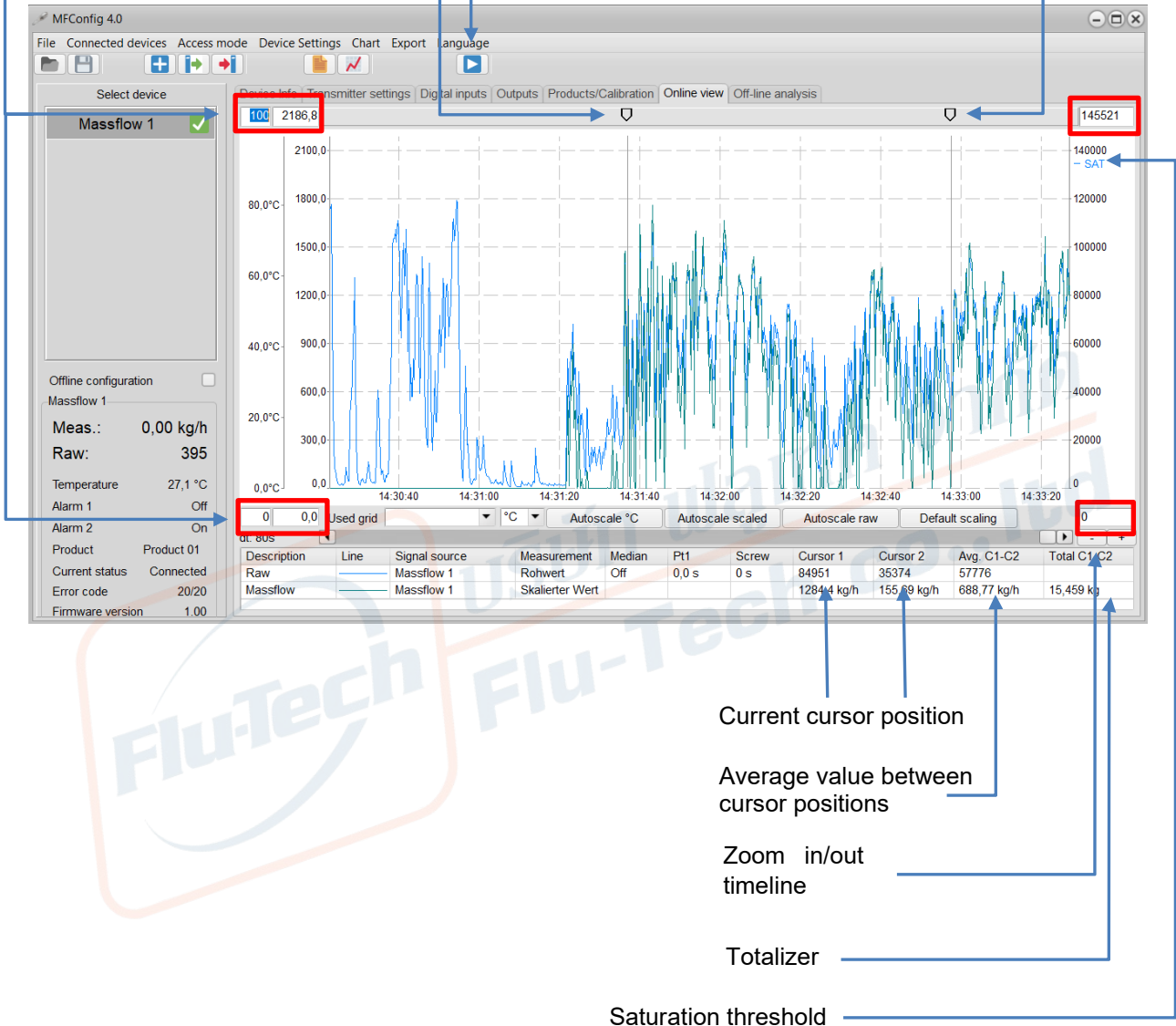

Current cursor position

Average value between cursor positions

Zoom in/out timeline

Totalizer

Saturation threshold

Grid used:
Auto scaling °C:

Auto scaling %:

Auto scaling raw:

Standard scaling:

Totalizer:

Selection of the measured value to which the grid refers
Automatic scaling of the temperature axis to the optimal display range. The scaling of the Y-axis changes after pressing the button

Automatic scaling of the Y-axis for the mass throughput values to the optimal display range

Automatic scaling of the Y-axis for the raw values to the optimal display range

All measurement value diagrams are scaled to the preset values in the "Scaling X/Y axis" menu

Displays the total product quantity in kg, t, or lbs over a defined period (between the cursors)

Add new display channel:

To display a measured value in real time in the diagram, add a new measured value curve in the 'Diagram' menu – 'Add new display channel' or by right-clicking in the diagram area.

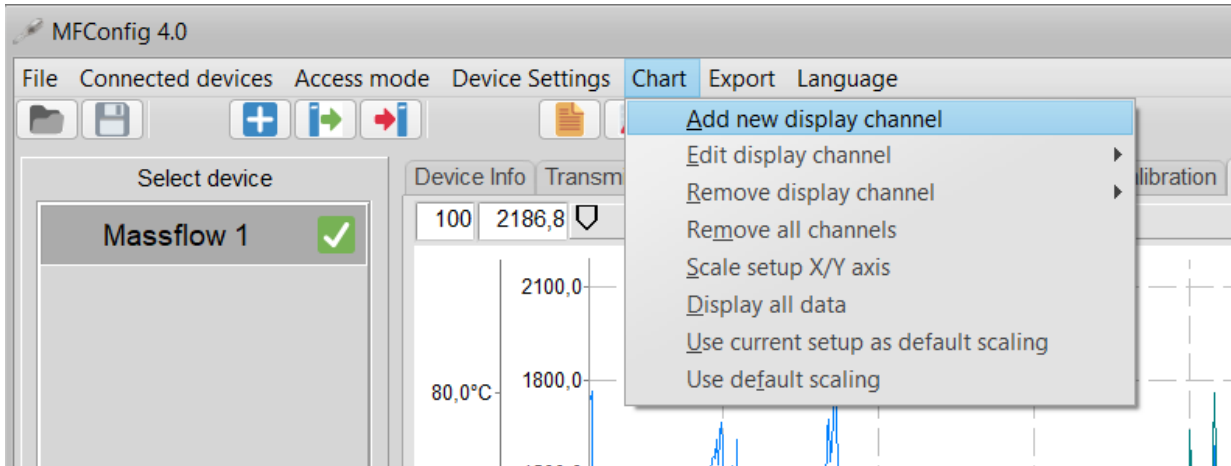

The configuration window for the new measurement channel appears:

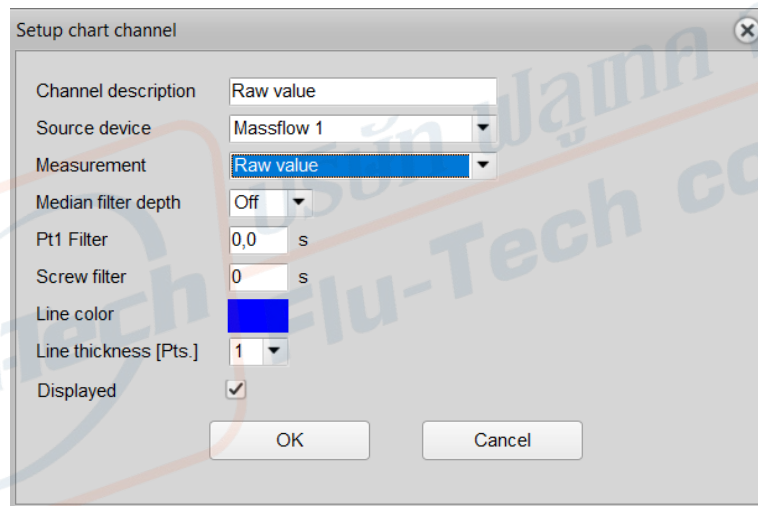

Description:	Description of the measured value (freely configurable)
Source device:	Selection of the mass flow measurement system (max. 8 measurement systems can be managed)
Measurement:	Selection of the measured value for online display (see above)
Median/Pt1/screw filter:	Setting the measured value filters for online display (only when 'Raw value' is selected). The filter setting affects the entire signal curve.
Line color:	Select the line color for the measured value curve
Line thickness:	Select the line thickness of the measured value curve
Display:	The line graph is only displayed when activated

The measurement channel is then listed below the display area. To analyze the mass throughput measurement values, the data curve can be paused using the "Pause" button, e.g., to calculate the average value between the cursor positions. The signal can be enlarged for analysis:

Zoom in/out: Temporal resolution of the signal using the "+/-" buttons

Free zooming: By drawing a rectangle around the signal area to be analyzed with the mouse

Edit display channel:

The settings for a channel can be changed in the "Diagram" ► "Edit display channel" menu (alternatively, the menu can be displayed by right-clicking in the diagram area) or by double-clicking on the channel line in the lower area of the diagram.

Delete display channel:

A channel can be deleted from the diagram in the 'Diagram' menu ► 'Remove *display* channel' (alternatively, the menu can be displayed by right-clicking in the diagram area). In the 'Diagram' menu ► 'Remove all channels', all channels are deleted from the diagram.

Scaling of measured values:

In the 'Scaling' ► 'Scale X/Y axis' menu, you can configure the basic settings for manual scaling of the measured values and the time axis.

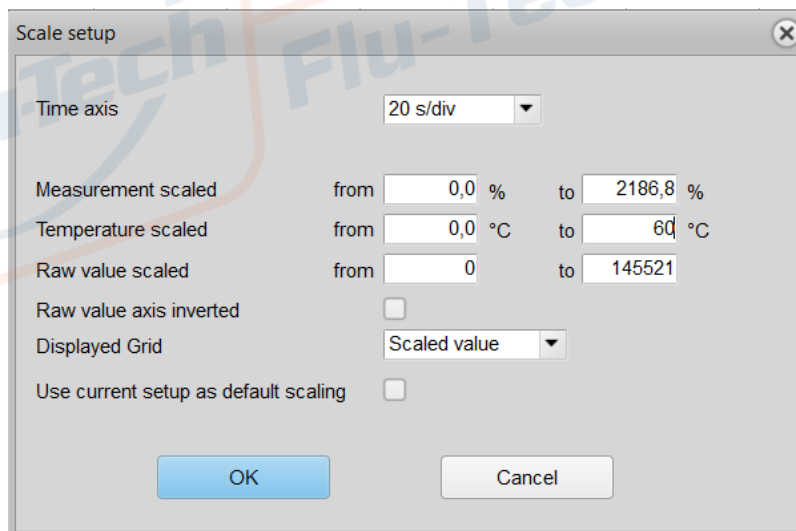

By activating the 'Use standard scaling' option, the settings for the diagram are saved. If a section of the diagram is changed using the zoom function, the saved scaling setting can be restored in the 'Diagram' ► 'Use standard scaling' menu or by clicking the 'Standard scaling' button below the diagram area.

Alternatively, the scaling can be automatically adopted from the diagram. In the "Diagram" ► "Use current setting as default scaling" menu, the current scaling settings for the X and Y axes are saved.

The 'Diagram' ► 'Show all data' function displays all measured values since the start of recording in a diagram.

Apply raw value for calibration

High-performance mass throughput measurement requires precise calibration under constant process conditions. The diagram module allows you to mark the most stable measurement range with the cursor and save the average value between the cursors as the calibration point.

First optimize the filter settings and then position the cursors on the desired range. Right-click on the measured value 'Avg. C1-C2' of the raw value and select the desired calibration point.

In the following example, the mass throughput was determined to be 1500 kg/h. Select 'Massflow 1 – Calibration point 1 – 1500kg/h' to apply the raw value for calibration. The second calibration point can be determined graphically in the same way.

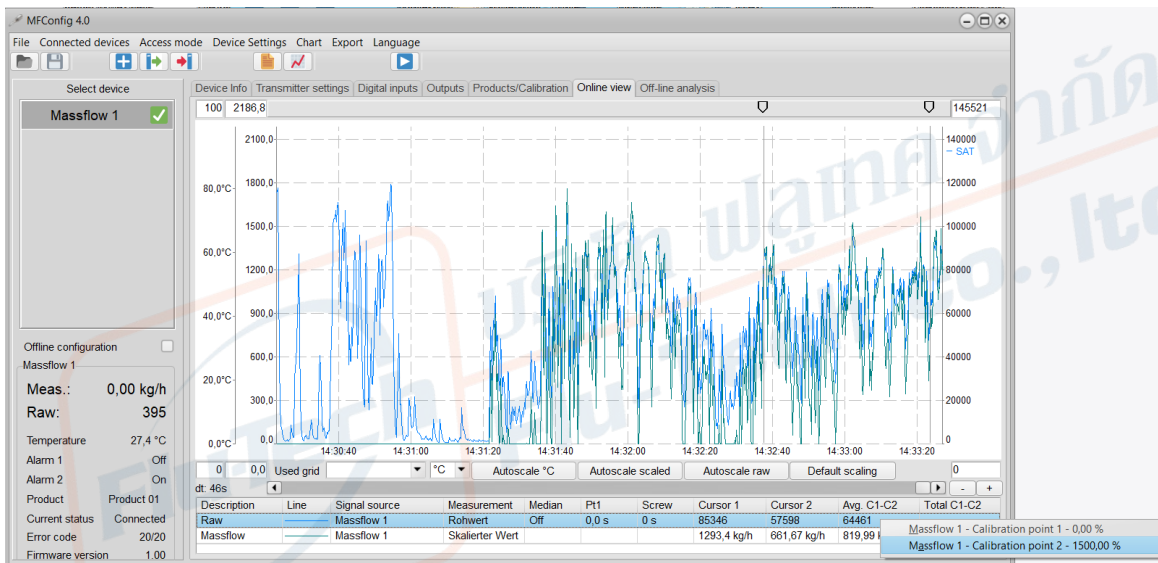

Exporting measured values

The measured values displayed can be exported as a csv file or as a bitmap for documentation purposes.

Export as csv file: In the menu 'Export' ► 'Export displayed data (.csv)' or via the button 

Export as bitmap: In the menu 'Save diagram as bitmap' or via the button 

Settings for csv export: Select the decimal point (. or ,) and the field separator for evaluation in Excel

15.1.4 Offline analysis

Saved measured values can be displayed and evaluated in the offline view. All measured values for a device are saved in a file. One file is created per day and device and saved in the selected

file directory. The data is saved on the hard drive of the PC or laptop connected to the transmitter.

To analyze the stored data, a new display channel is first created by selecting the log file. The name of the log file consists of the device name, the serial number of the transmitter, and the date of the recording.

Example:

For the measuring point "Flow behind silo," the mass throughput from March 6, 2025, is to be analyzed. To do this, the name of the measuring channel is defined in the menu "Diagram" ► "Add new display channel" and the file "MF3000 test_000_20250306.mflog" is selected. All measurement data from March 6, 2025 is available. To display the mass throughput, the "Scaled value" parameter is selected under "Measurement."

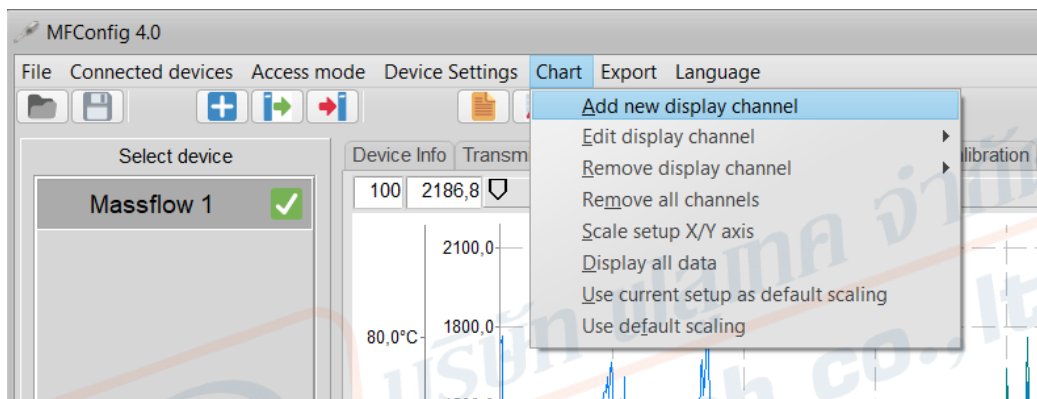

The following window appears:

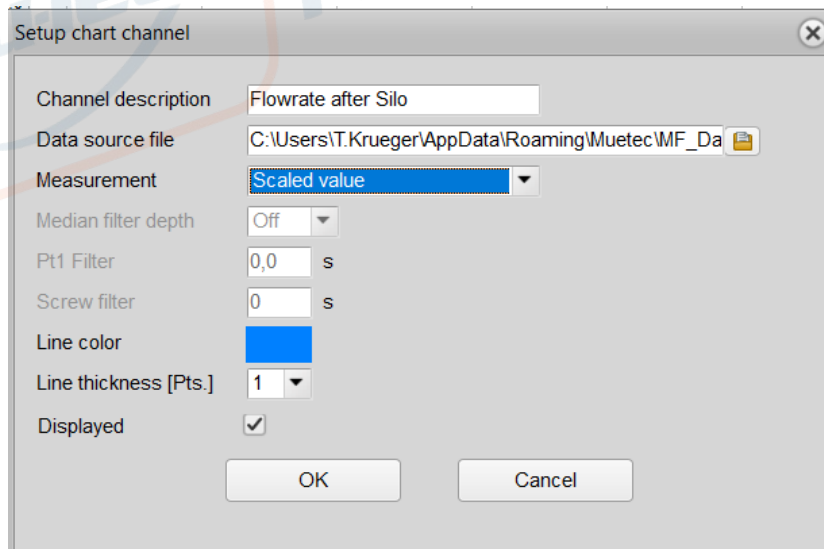

Description: Description of the measured value (freely configurable)

Log file directory: Select a log file for analyzing the measured values. The file name contains the device name, the serial number of the transmitter,

and the date (yyyymmdd). Example: *MF3000 test_003_20250306.mflog*. The directory for the log file is specified in the device configuration (see menu '*Device management*' ► '*Edit settings*' ► '*Device name*').

Measurement:	Selection of the measured value for offline analysis (see above)
Median/Pt1/Snail filter:	Setting the measured value filters for offline analysis (only when 'Raw value' is selected). The filter setting affects the entire signal curve.
Line color:	Select the line color for the measured value curve
Line thickness:	Select the line thickness of the measured value curve
Display:	The line graph is only displayed when activated

The directory for the log file is specified in the device configuration (see menu '*Device management*' ► '*Edit settings*' ► '*Device name*').

The operation and functions of the graphical user interface are identical to those of the online view.

15.2 Parameterization in expert mode

Additional functions and tabs are enabled in expert mode. Expert mode is set via the '*Access mode*' ► '*Expert*' menu.

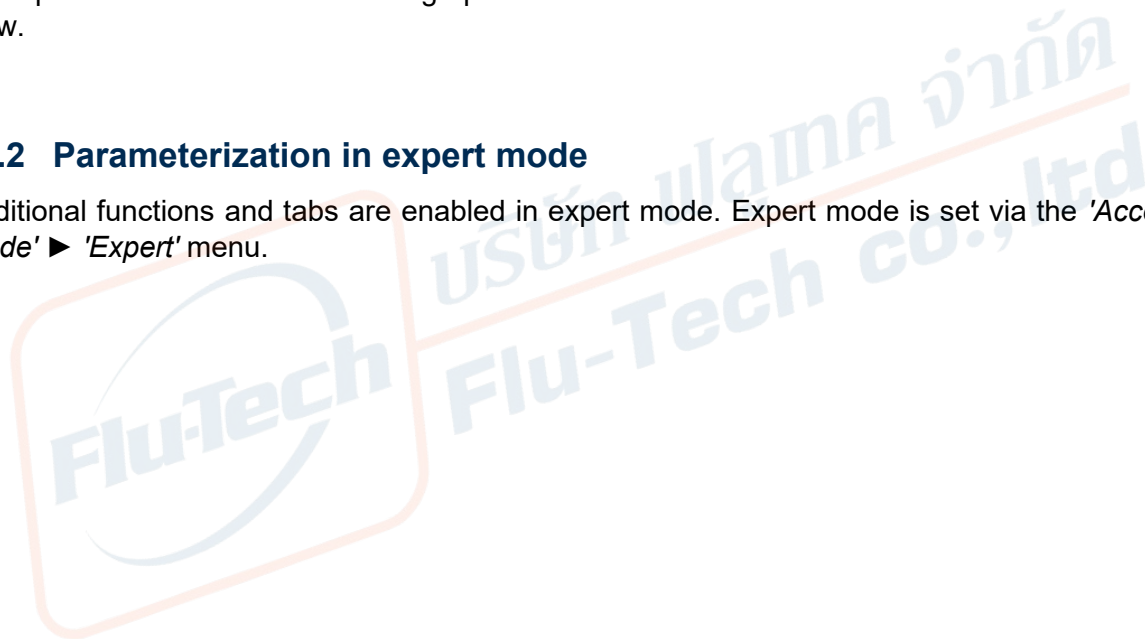

15.2.1 Transmitter settings (additional functions)

In expert mode, the menu for configuring the RS485 serial interface for communication with an external PLC appears

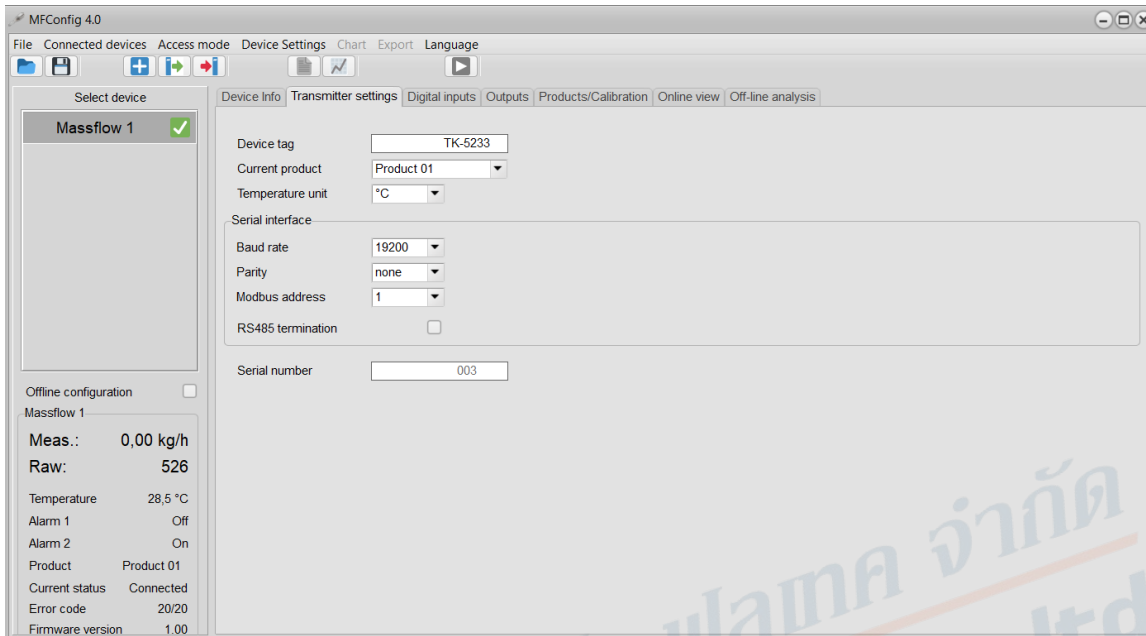

- RS485 interface:** Configuration of the RS485 interface for communication with an external PLC. Communication takes place with 8 data bits and one stop bit.
- Baud rate:** Transmission speed to the PLC (max. 115200 baud)
- Parity:** Setting of the parity bit (E: even, O: odd, N: none)
- Modbus address:** Address of the MF3001 transmitter. When communicating with multiple transmitters via an RS485 bus, the transmitters must be assigned different addresses
- RS485 termination:** Terminating resistor for terminating the RS485 bus when communicating with multiple participants (the first and last participants are terminated with a terminating resistor)

15.2.2 Digital inputs

Configuration of the digital inputs. The MFI 3001 transmitter is equipped with 4 digital inputs with different functions.

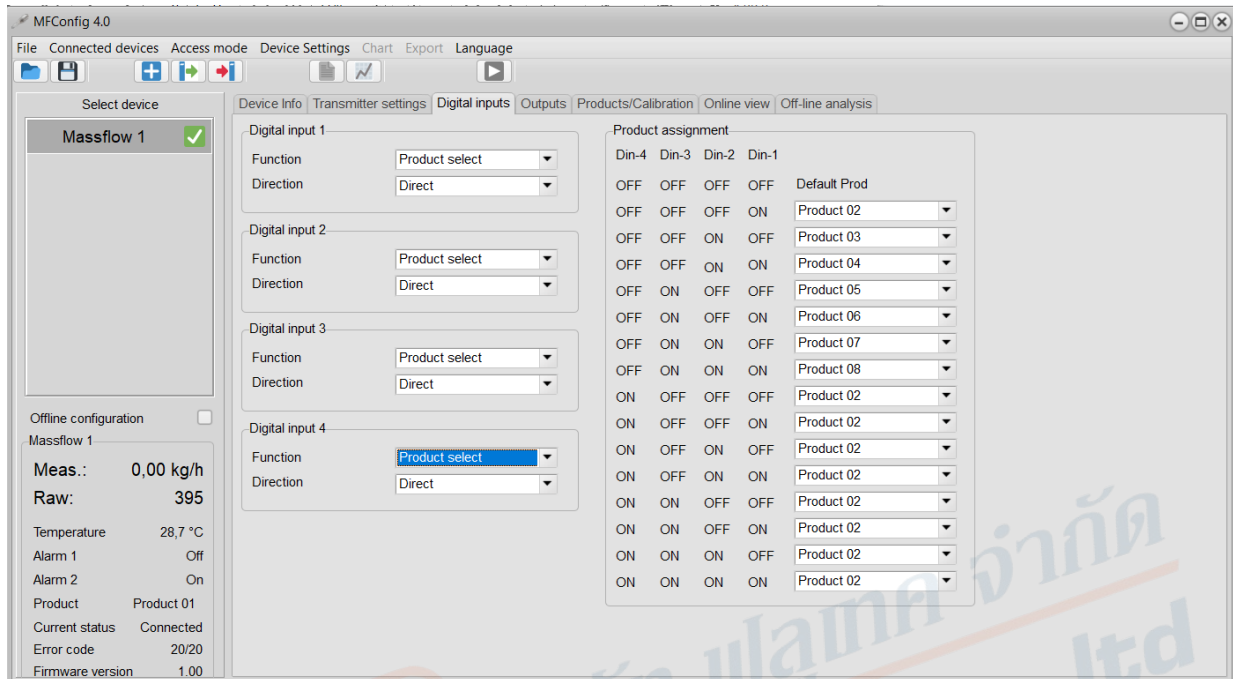

No function:

The digital input is deactivated

Freeze measured value:

The measured value is frozen when a rising edge is detected (direction of action can be set via "Direction") and does not change.

Product selection:

Up to 16 different products can be selected via an external hardware signal (e.g., PLC or with BCD switch). The switching of the products is binary-coded according to the table in the attached figure. In the example above, product 3 is selected by connecting inputs 3, 4, and 1 to a 0V voltage level and input 2 to a 24V input level.



When selecting products via digital inputs, the selection of products in the "Transmitter settings" and "Products/Calibration" menus is deactivated.

15.2.3 Outputs

The alarm outputs and the analog output for data transmission to a PLC are configured in the "Outputs" menu.

A relay and a transistor output are available for outputting the alarm values. In addition, alarm values can be output as analog values. The output value in the event of an alarm can be freely configured.

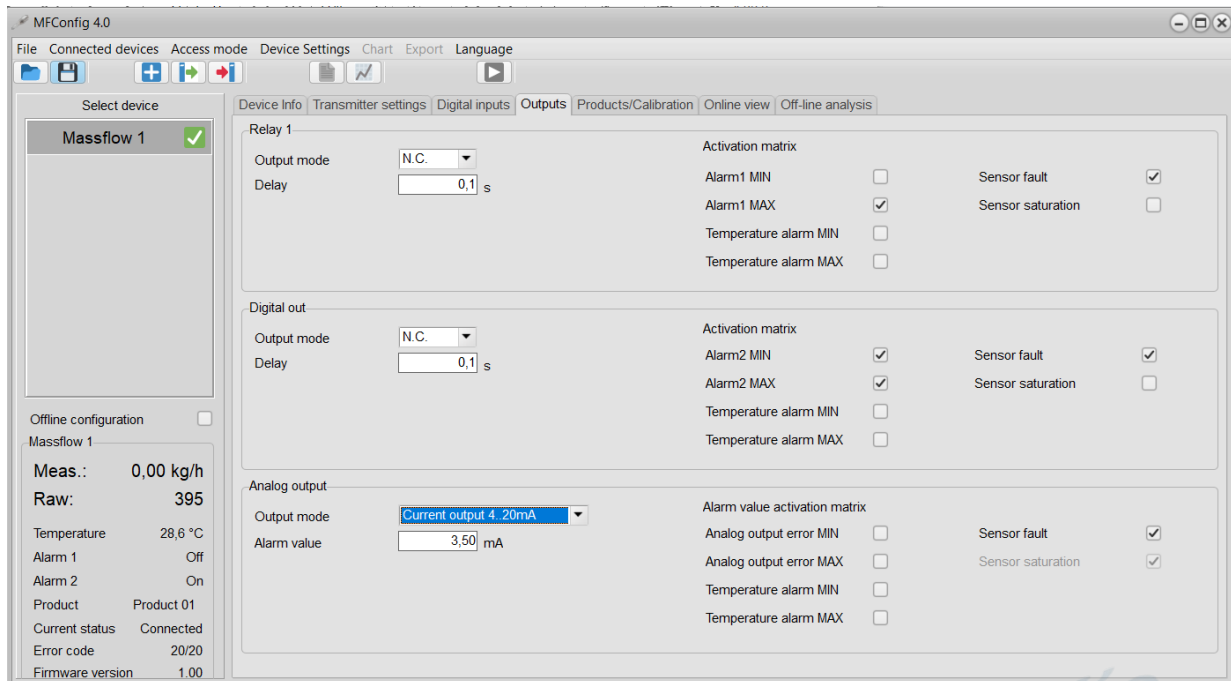

Output mode:	Direction of action of the alarm output
Delay:	Switching delay time of the output value
Activation matrix:	Selection of the available alarm value (mass flow rate min/max, sensor over/under temperature, sensor error)
Analog output:	Configuration of the analog output
Output mode:	Selection of current (4...20mA) or voltage output (0...10V)
Alarm value:	Definition of the output value when an alarm is detected
Alarm value activation matrix:	Configuration of alarm states for the analog output (mass flow rate min/max, sensor over/under temperature, sensor error). In the event of an alarm, the configured alarm value is output

15.2.4 Products/Calibration (additional functions)

The following additional functions are enabled in expert mode:

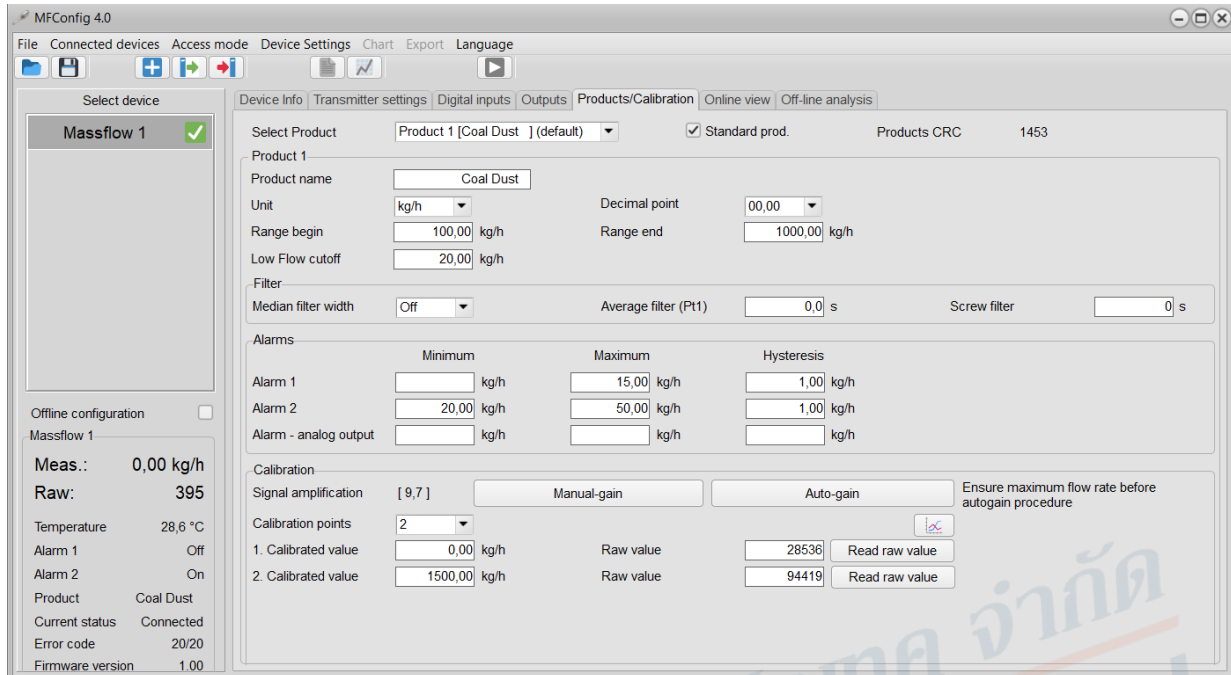

- Screw filter: Special filter for eliminating periodic interference peaks (0...10s).
- Alarms: The alarm thresholds can be set individually for each product.
- Alarm 1 / 2 min: Lower limit of the measuring range for critical mass throughput based on digital output value
- Alarm 1 / 2 Max: Upper limit of measuring range for critical mass throughput based on digital output value
- Alarm–
Analog output min: Lower limit of measuring range for critical mass flow rate relative to analog output value
- Alarm–
Analog output max: Upper limit of measuring range for critical mass flow rate relative to analog output value
- Hysteresis: Adjustable hysteresis relative to the switching point

15.3 Read/write parameters



Changes to parameters or calibration curves are initially stored temporarily and must be saved to the transmitter's memory after each change in the "Device settings" ► "Write configuration" menu or by clicking on the symbol 

After changing parameters and switching to another menu or exiting the program, a prompt to save the parameters appears.

After changing parameters and switching to another menu or exiting the program, a prompt appears asking you to save the parameters.

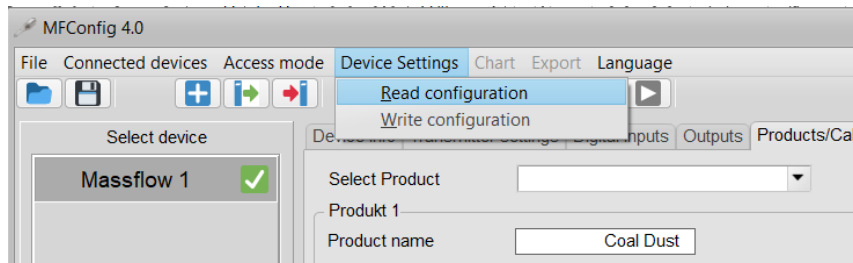



The parameters of a device are transferred to the PC in the 'Device settings' ► 'Load configuration' menu or by clicking on the  and can then be changed.

15.4 Save/load software configuration

When replacing a transmitter or for service purposes, the transmitter parameters can be saved on the PC and loaded into another transmitter.

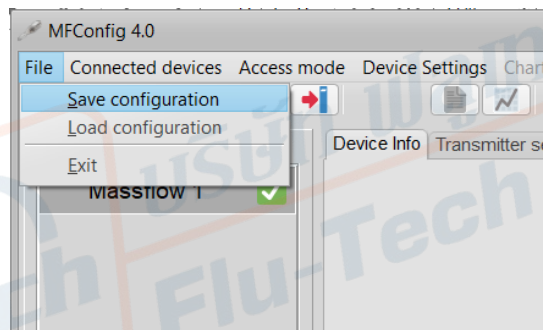
The current configuration is *saved* in the 'File' ► 'Save configuration' menu or with the diskette icon 



An existing configuration is loaded in the 'File' ► 'Load configuration' menu or with the folder icon 

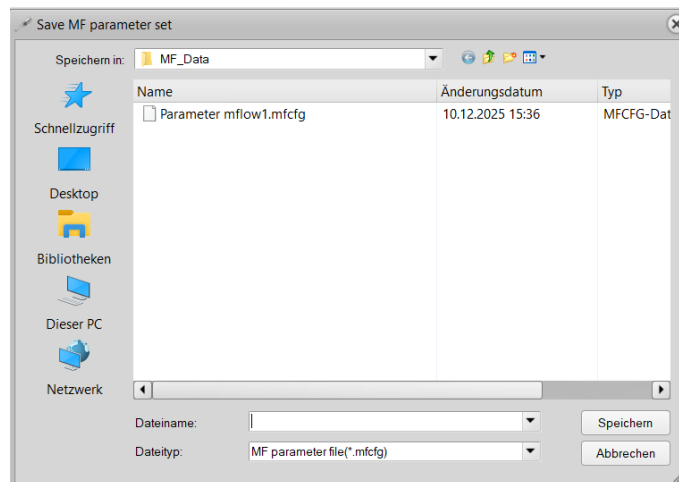

16 Calibration

Good and accurate calibration is essential to achieve high measurement accuracy. First, the number of calibration points must be specified. In most cases, 2 calibration points are sufficient, assuming linear behavior. A maximum of 5 calibration points can be selected.

Example of successful 2-point calibration with linear product behavior

2-point calibration, linear behavior

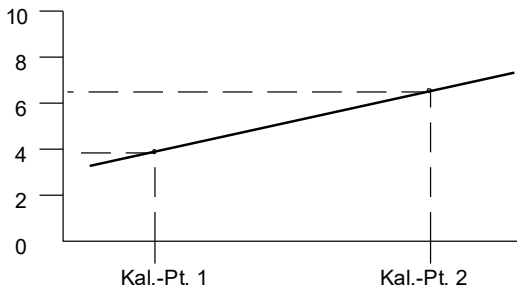

Measurement Results

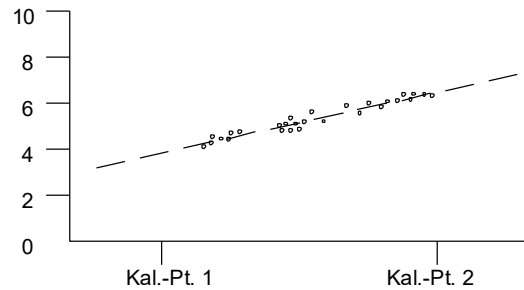

Example of successful 3-point calibration with non-linear product behavior

3-point calibration, non-linear behavior

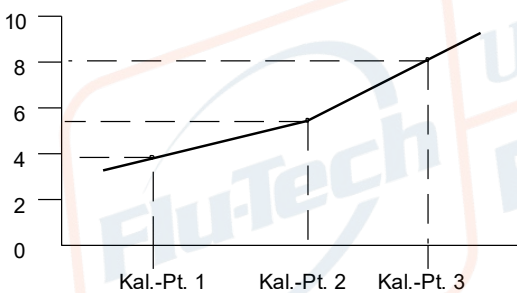

Measurement Results

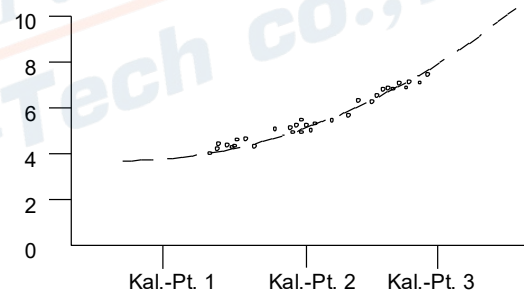

The calibration time (time during which raw values are recorded) varies depending on the process. A long calibration time can be selected for stable processes. The measured values queried by the sensor are integrated during the calibration time, and the mean value of the integrated values is stored as the raw value for the calibration point.

16.1 Product selection for calibration

Up to 24 products can be stored in the transmitter. An individual calibration curve can be stored for each product.

First, select a product from the "Select product" list and select the unit for the mass flow display. The name of the product can be freely defined. By activating the "Current product" check box, the mass flow is calculated using the stored calibration curve.

The resolution of the analog output is increased by limiting the mass flow rate range.

Example:

The expected mass flow rate is between 10 and 1000 kg/h. Recommended setting for scaling the analog output: 5 kg/h (range start 4mA) – 1100 kg/h (range end 20mA).

16.2 Number of calibration points

A calibration curve can be created with a minimum of 2 and a maximum of 5 calibration points, depending on the accuracy requirement. In most cases, a 2-point calibration is sufficient. The calibration menu is described in **section 15.3**.

16.3 Start of calibration

Once the number of calibration points has been determined and the process is stable (constant mass flow rate and conveyor speed), the first step is to adjust the signal gain to the process.

Press the auto gain button in the calibration menu.

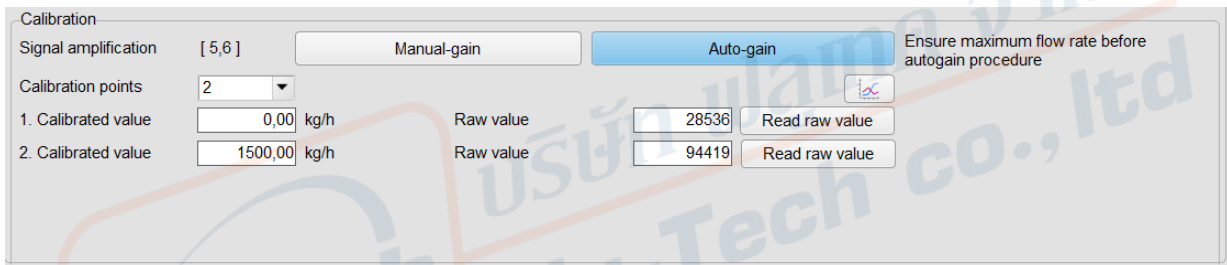

Calibration			
Signal amplification	[5,6]	Manual-gain	Auto-gain
Calibration points	2	Ensure maximum flow rate before autogain procedure	
1. Calibrated value	0,00 kg/h	Raw value	28536
2. Calibrated value	1500,00 kg/h	Raw value	94419

A window opens showing the current gain factor and an indicator for setting the gain factor (green bar). The setting takes about one minute. The green bar indicates whether sufficient data is available for this step.

As soon as the "Accept" button is no longer grayed out and is active, it can be pressed and the new gain factor saved. This automatically sets the gain factor of the preamplifier to the maximum range. This helps to increase the resolution and measurement accuracy. Auto gain should therefore be performed for each new material. The gain factor is stored in the transmitter together with the calibration data.

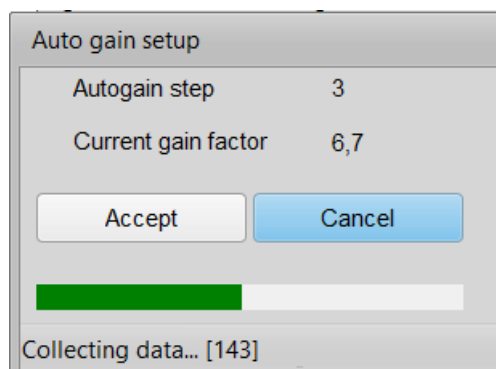

Auto gain setup	
Autogain step	3
Current gain factor	6,7
Accept	Cancel
Collecting data... [143]	

Optionally, the gain factor can also be set manually. Press the Manual Gain button in the calibration menu. A window opens in which the gain can be set using a slider.

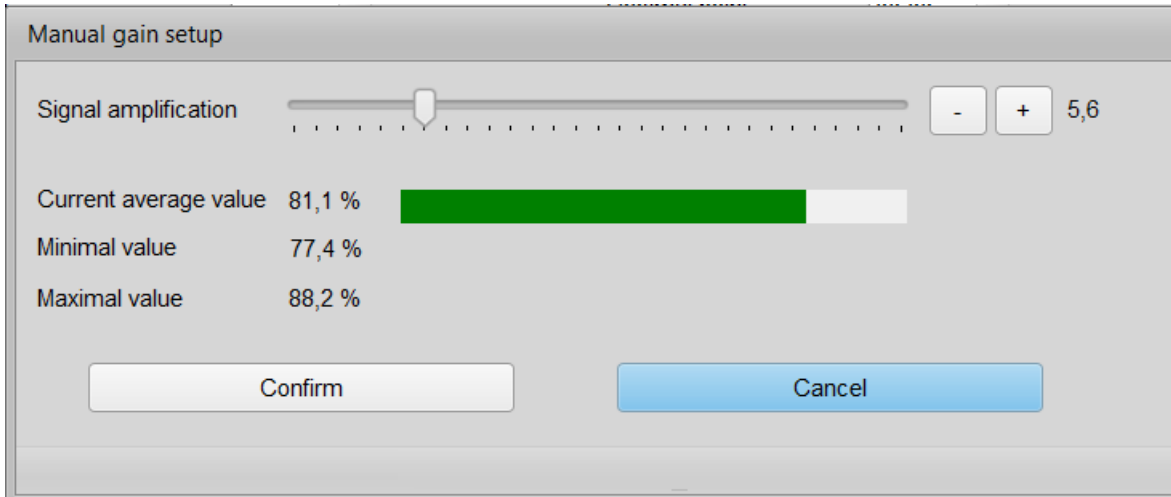

In the example above, a gain factor of 5,6 was selected. The current average value (green bar in the example above) shows the averaged raw value taking into account the current gain. If the current average value is below the saturation limit, the bar is displayed in yellow. A blue bar indicates that the gain must be increased. If the saturation limit is exceeded, the bar is displayed in red. The gain factor must then be reduced.

The gain factor must be selected manually so that the display is in the green range. The minimum and maximum values show the fluctuations of the last measurements. Clicking on the "Confirm" button applies and saves the gain factor setting.



The gain must be selected so that the measured value is not overdriven (saturation). When the saturation limit is reached, the scaled measured value and the raw value are colored orange. If the limit is exceeded, the measured values are colored red and the scaled value is replaced with the word "Saturation." In this case, reduce the gain.

You can then begin the actual calibration. Start the calibration by pressing the "Record raw value" button in the "Calibration" section. The window below opens and the calibration begins:

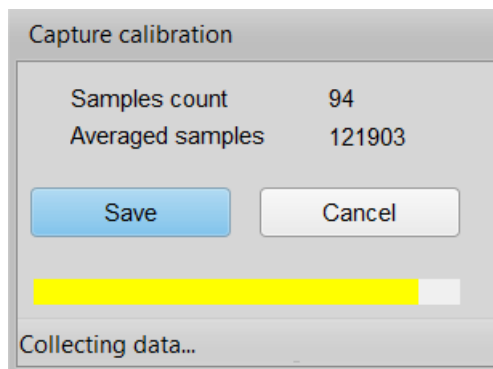

End the recording of the raw value by pressing the "Save" button. The raw value is then averaged over the number of samples. The calibration time should not be less than 30 seconds.

The bar indicates the signal strength of the current measured value.

16.4 Notes on calibration

- The sensor must be calibrated to at least two different throughput values. More than three calibrations are required for very accurate measurements.
- It is essential that the flow rate is kept constant during calibration.
- The accuracy of the subsequent continuous measurement of the system depends significantly on the accuracy of the reference values and thus on the calibration.
- If the sensor position, material type, shape, and speed are changed, the calibration may need to be repeated. Removal and reinstallation may also require recalibration.
- The actual mass throughput must be determined accurately for input into the calibration function.
- This can be done either by collecting the material in a big bag and weighing it, or by processing a previously weighed quantity from a silo, recording the time in each case.
- For a constant continuous throughput, it must be ensured that the conveyor and dosing systems upstream of the conveyor line (rotary valves, screw conveyors, conveyor belts, etc.) are always filled and conveying evenly.
- In order to minimize possible inaccuracies in the mass throughput determination in the start and end phases of the conveying time, the time window for the throughput measurement should be as large as possible. Furthermore, the start-up and deceleration times (accelerations) of the conveying systems should be minimized.
- The calibration function of the sensor should only be started when the material throughput is constant.

The following diagram shows the different time periods involved in calibrating a mass throughput:

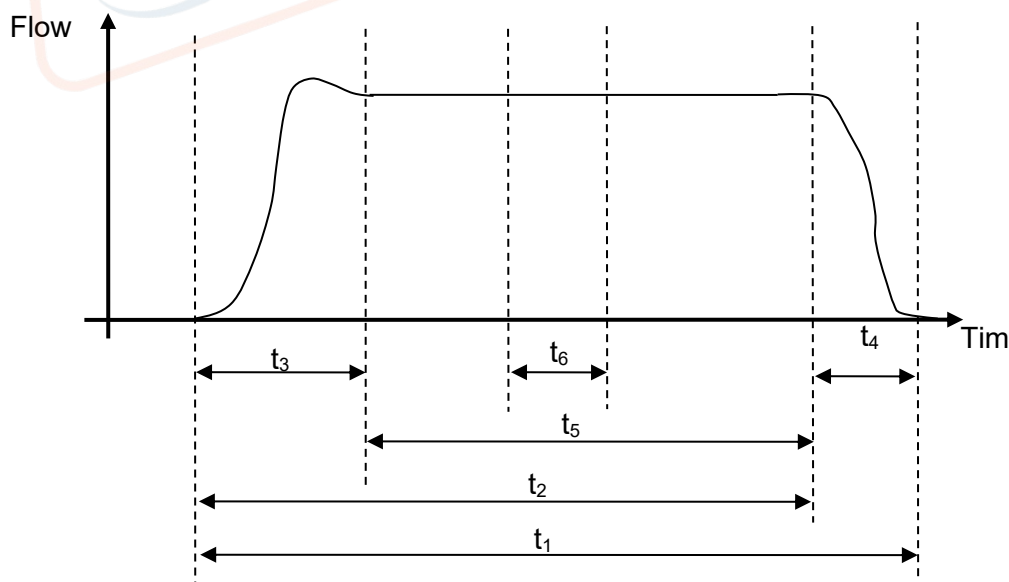

- t1 Period during which the total amount of material that has flowed through the conveyor system is collected for the actual throughput calculation. Includes the run-on of conveyor systems and material quantities in the conveyor system. To record the correct material quantity, the total material throughput over the period t1 must be recorded accurately.
- t2 Period from when the conveyor is switched on to when it is switched off. E.g., switching a rotary valve on and off or opening and closing a slide valve.
- t3 Start phase of conveying with non-constant flow.
- t4 Follow-up period of conveyance with non-constant flow.
- t5 Period during which the mass throughput is constant. This period should be several times longer than the start period and follow-up period in order to minimize inaccuracies from the start and follow-up.
- t6 Period during which the calibration of the MF3001 is started and performed. This period must be within t5. During this period, the mass flow rate is constant.

16.5 Completion of calibration

The recording of the raw value for the first calibration point is completed by pressing the 'Save' button and the average value is saved. The result of the material weighing or the calculation of the mass throughput based on this can be entered at a later point in time. A minimum recording time of 30–60 seconds is recommended.



The parameters must be saved after each calibration. (shortcut button).



The second calibration point is determined in the same way.

Plausibility check:

Clicking the button  opens an X/Y diagram of the calibration values. This allows the calibration to be checked for plausibility. The measurement points should lie on a straight line if possible.

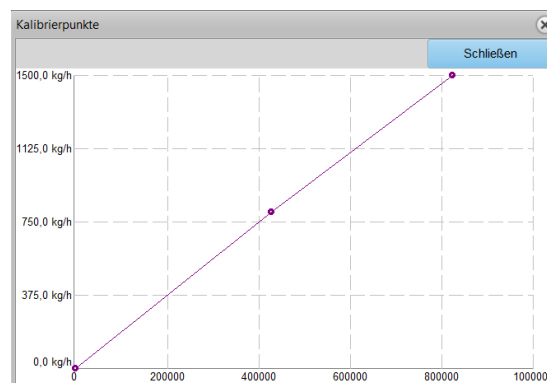

16.6 Determining the optimal filter value

The software offers various filter algorithms for smoothing the digital and analog output signal. A combination of a median filter for eliminating outliers and a mean filter for smoothing the signal is recommended. The following procedure is recommended for determining and setting the optimal filter values:

- 1) Set the optimal filter values in the online view (e.g., by double-clicking on the display channel of the raw value).
- 2) Transferring the filter values to the "Products/Calibration" menu
- 3) Program the parameters in the transmitter

Raw signal without filter settings:

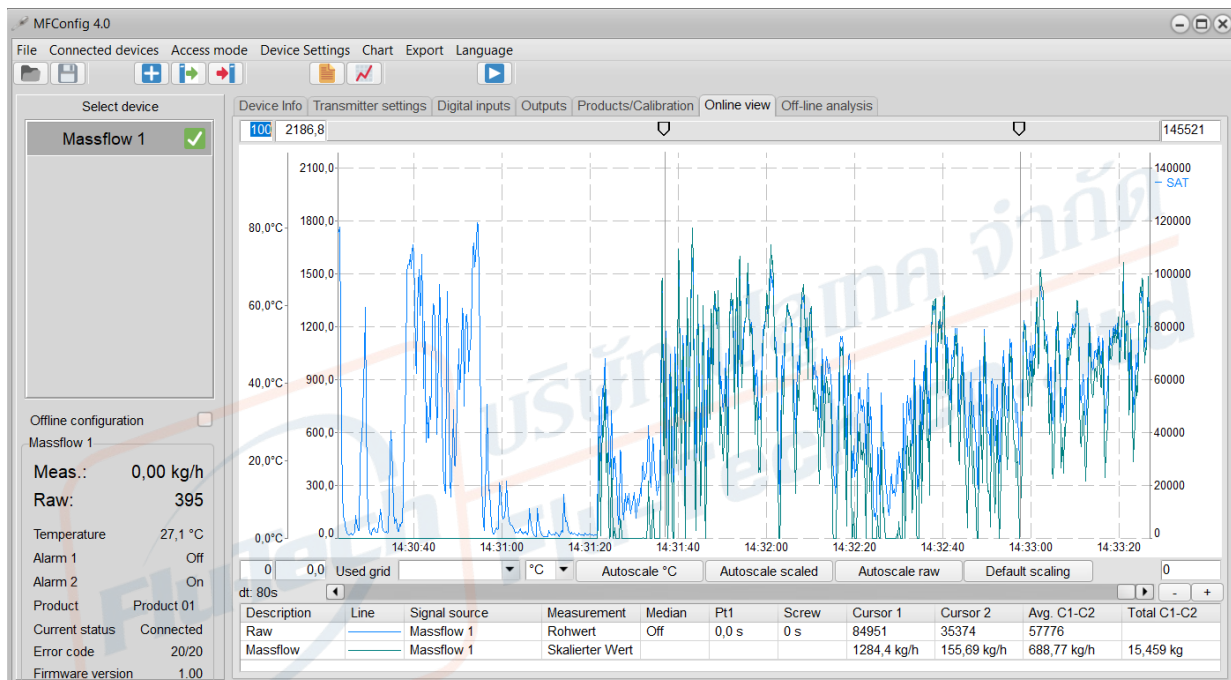

Raw signal with median filter activated over 7 measured values:

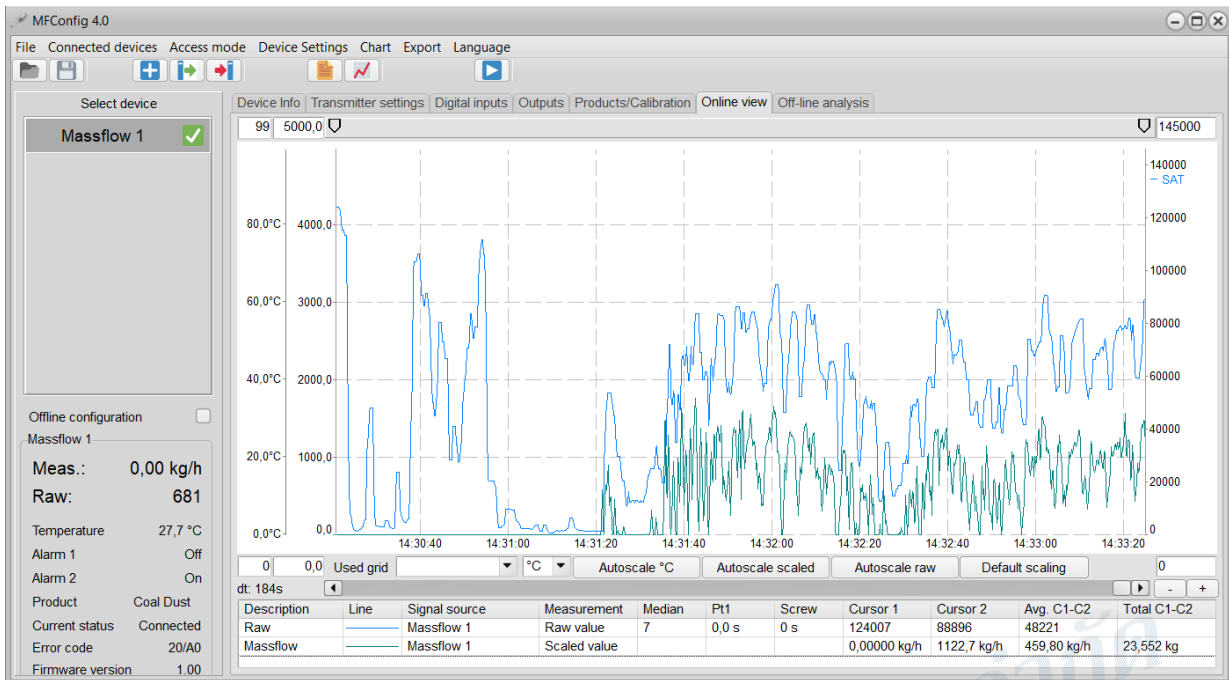

Raw signal with median filter activated over 7 measured values and mean value filter PT1 (filter length 5s):

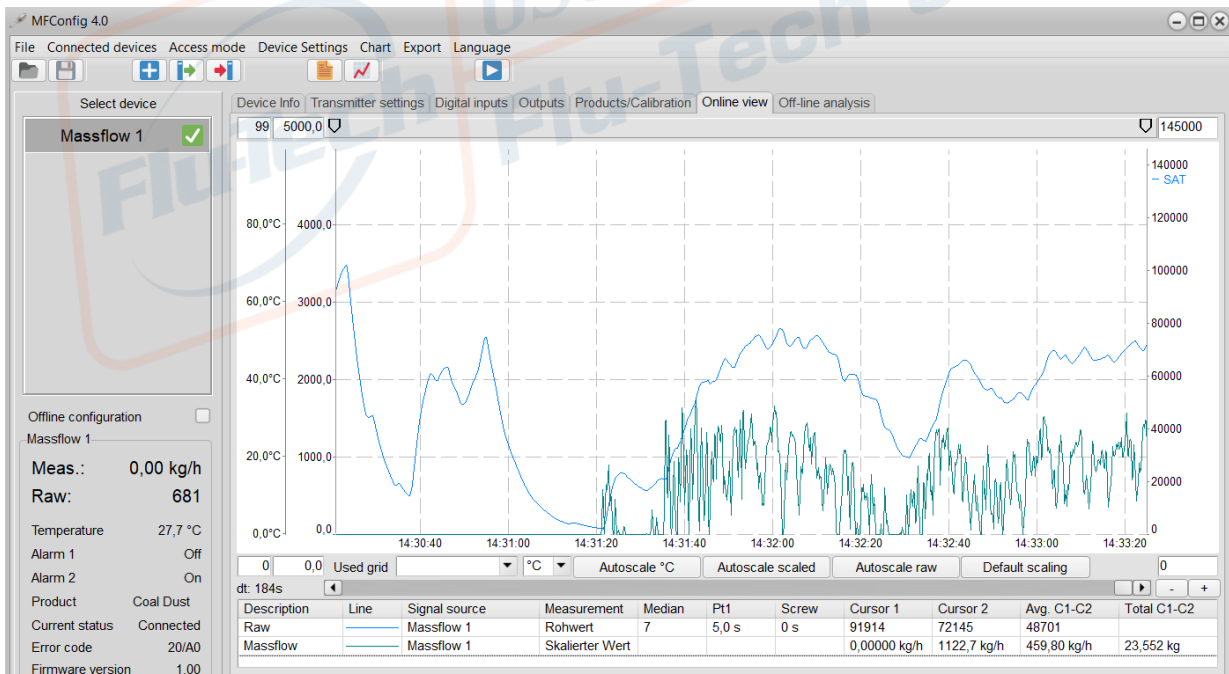

A large time constant of the median filter results in optimal smoothing of the signal, but sudden changes in the signal curve are registered with a time delay. Therefore, a combination of a median filter and subsequent smoothing using a PT1 average filter is recommended, e.g., a median filter of 3 or 5 measured values combined with an average filter of up to 30 seconds.



The filter values only have an active effect on the analog output after the parameters have been programmed on the transmitter (button )

16.7 Graphical determination of a calibration point

As an alternative to automatic detection of the raw value, a calibration point can also be determined graphically in the online view. To do this, position the cursor on the desired value range. Right-click on the measured value 'Avg. C1-C2' of the raw value and select the desired calibration point.

In the following example, the mass throughput was determined by weighing at 1500 kg/h. The average value between the cursors is 67878 digits. Select 'Mass flow 1 – Calibration point 2 – 1500 kg/h' to apply the raw value for calibration. The second calibration point can be determined graphically in the same way.

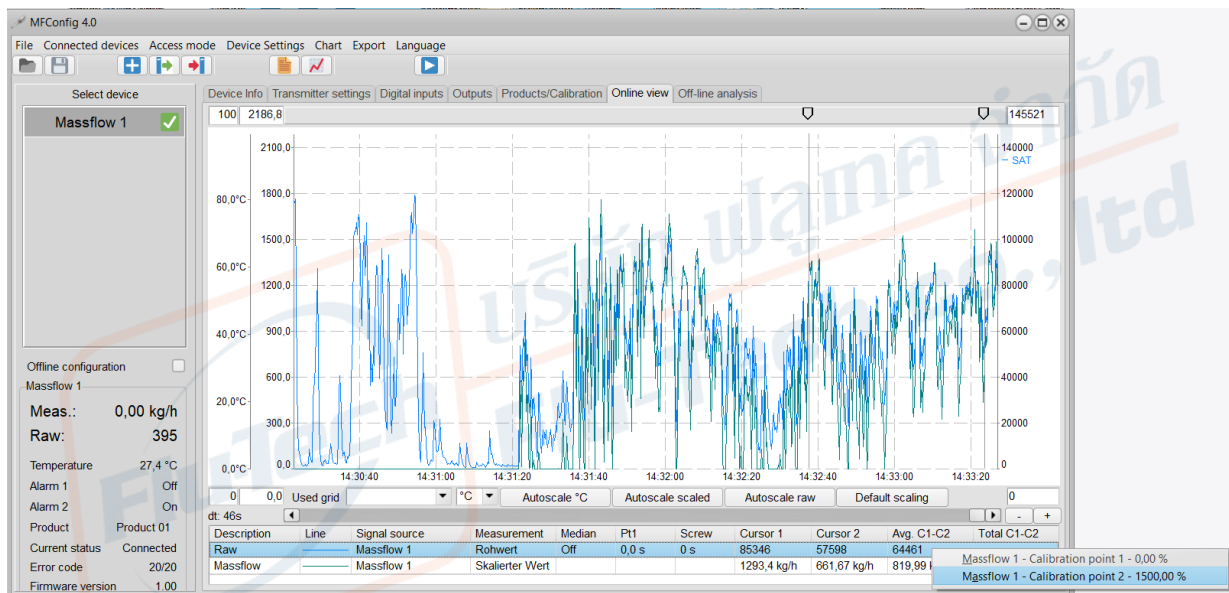

16.8 Offline calibration

Similar to the graphical determination of a calibration point, calibration can also be performed using historical data. This allows the mass throughput to be determined at any point during the ongoing process, which is then later assigned to a historical raw value.

Example:

A mass throughput was determined on June 3, 2025, at 12:41 p.m. In the offline analysis, a new measurement channel is created with the raw values from June 3, 2025, and the cursor is placed in the corresponding time range. The average value between the cursors can be transferred directly from the diagram as a calibration point.

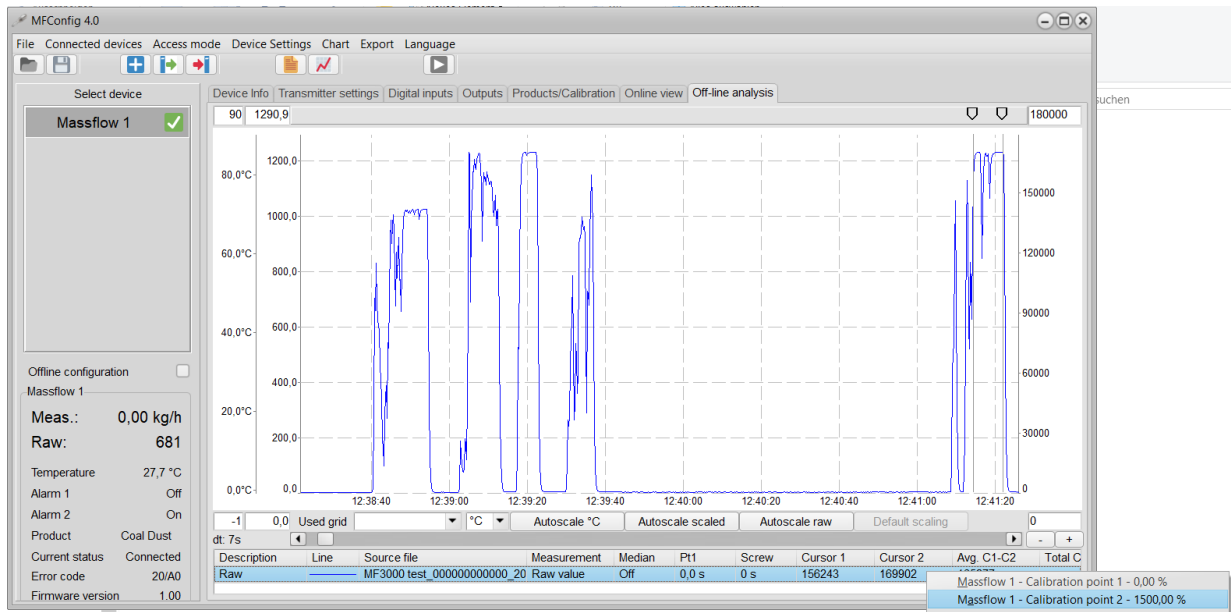

The determined raw value assigned to the mass throughput appears in the "Products/Calibration" configuration tab.

Product 1 [Coal Dust] (default) Standard prod.

Product name: Coal Dust

Unit: kg/h | Decimal point: 00,00

Range begin: 100,00 kg/h | Range end: 1000,00 kg/h

Low Flow cutoff: 20,00 kg/h

Filter: Median filter width: Off | Average filter (Pt1): 0,0 s

Calibration

Signal amplification: [5,6] | Manual-gain | Auto-gain | Ensure maximum flow rate before autogain procedure





Calibration points: 2

1. Calibrated value	0,00 kg/h	Raw value	2800	Read raw value
2. Calibrated value	1500,00 kg/h	Raw value	165277	Read raw value

17 Troubleshooting

The following table contains a list of possible causes of errors when using the mass throughput system. If the error is not resolved, please contact Mütec Instruments technical support:

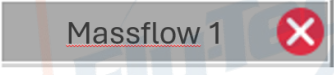
17.1 Software or hardware-related causes of errors

Error pattern	Possible cause	Action
Parameters are not displayed, device is grayed out, data is being recorded. Software signaling: 	Parameters not loaded after starting the software	Select and click on the device to be parameterized
Measured value is not displayed, no data recording, yellow status LED on transmitter is not lit. Software signaling: 	Communication between PC and transmitter interrupted	Check the USB connection to the transmitter, check the interface parameters, check the virtual COM port in Device Manager. Reinstall the driver for the virtual COM port
Measured value is not displayed, no data recording, yellow status LED and green power LED on the transmitter are not lit. Software signaling: 	Power supply interrupted	Check power supply
Measured value is not displayed, no data recording, yellow status LED on transmitter does not light up. Software signaling: 	Device not active	Activate device in the menu (Device management ► Device active ► "Device name")
Measured value is not updated, red LED on transmitter is lit, software signaling: 	Connection from sensor to transmitter interrupted	Check connection cable from sensor and wiring
Analog output remains at max. value	Current mass flow rate is greater than end of range in the product menu	Check the scaling of the current output in the "Products/Calibration" menu
Measured value is not displayed in the PLC	<ul style="list-style-type: none"> - Analog output defective - PLC analog input card incorrectly configured 	<ul style="list-style-type: none"> - Measure analog output value with multimeter on transmitter

17.2 Process-related causes of error

Error pattern	Possible cause	Action
Measuring system outputs incorrect value	<ul style="list-style-type: none"> - Calibration incorrect - Conductive deposits on the sensor surface 	<ul style="list-style-type: none"> - Recalibrate the system - Incorrect calibration curve used - Check whether calibration points are plausible (menu "Products/Calibration" -> press button for plausibility check) - Remove deposits on the sensor
Significant fluctuations in measured values	<ul style="list-style-type: none"> - Product speed changes - Bulk density changes (air pockets, large particles) - Significant moisture fluctuations in the product - Uneven product distribution - Strongly pulsating product conveyance - Vibrations - Influence of microwave measurement by moving parts near the sensor - Sensor not grounded or shield of measuring cable not connected 	<ul style="list-style-type: none"> - Measurement at constant product speed - Use individual calibration curves for different products - Check the installation position or location of the sensor - Ensure sufficient infeed and outfeed distances - Ensure sufficient distance from screw conveyors and rotary valves - Check grounding and shielding

18 Disposal

The device must be disposed of in accordance with environmental regulations. It must be ensured that a defective device cannot be reused.