

HUMY 301

Continuous inline moisture measurement of bulk goods



Application

Moisture in solids is an important parameter that influences the quality of a product and the economic efficiency of production. Nevertheless, in many companies the product moisture is only determined in the laboratory. These random sample measurements are time-consuming and the results are only available with a delay.

The HUMY 301 inline moisture measurement system is the better alternative. Its real-time measurement enables an immediate response to moisture changes in the process. The measurement results can be used to control a dryer or automatic humidification or to continuously monitor the process.

Industries

Building materials
Carbon
Chemical industry
Fertilizers
Food
Metal processing
Paper
Pet food
Pharma Plastic
Power generation
Recycling
Steel

Tobacco
Wood
etc.



Advantages

- Real-time monitoring of product moisture
- No laboratory samples necessary
- The maximum permissible water content of a product can be safely maintained; this increases quality and reduces costs
- Saves energy by controlling the drying process
- Very accurate measurement results (up to 0.1 % accuracy, depending on the material)
- Measures the total water content, not just the surface
- Robust design, suitable for extreme environmental conditions
- Encapsulated sensor, protected against humidity and vibrations
- Highest ATEX classification (dust: zone 20; gas: zone 0)
- Simple installation and retrofitting, e.g. on conveyor belts, screw conveyors, pipes and chutes

Measuring principle

The HUMY 301 is a capacitive measuring system. This offers numerous advantages, e.g. in comparison to NIR sensors (sensitive to ambient light and contamination) and microwave sensors (limited at high humidity). The basic principle of the measurement is simple: The sensor of the HUMY 301 generates an electromagnetic field. During the measurement, the dielectric constant and the high-frequency attenuation of the solid are measured in the high-frequency wave range. As the permittivity of water and most bulk solids are very different, the water content of a material can be indirectly derived from this.

The HUMY 301 measures moisture in real time. The result represents the total water content of a material -

not only from its surface. The sensor's field lines penetrate up to 200 mm deep into the material. To achieve optimum results, the measurement should be taken in contact with the material as it flows past the sensor.

The measurement result has an accuracy of up to 0.1 % - depending on the bulk material. It is not influenced by changes in electrical conductivity, pH value, surface structure, color, steam, dust or extraneous light. On the other hand, the bulk density, height and speed of the material should be kept as constant as possible. Several calibrations for different materials or material properties improve the measurement results.

New functions

- Detailed analysis options through graphical user interface
- User-friendly calibration and parameterization
- Extended batch mode function
- Additional digital inputs, e.g. for product switching, up to 16 products
- Faster data acquisition thanks to new microprocessor
- Long-term data storage for offline analysis and offline calibration
- Simultaneous display of 8 measured values / measuring systems

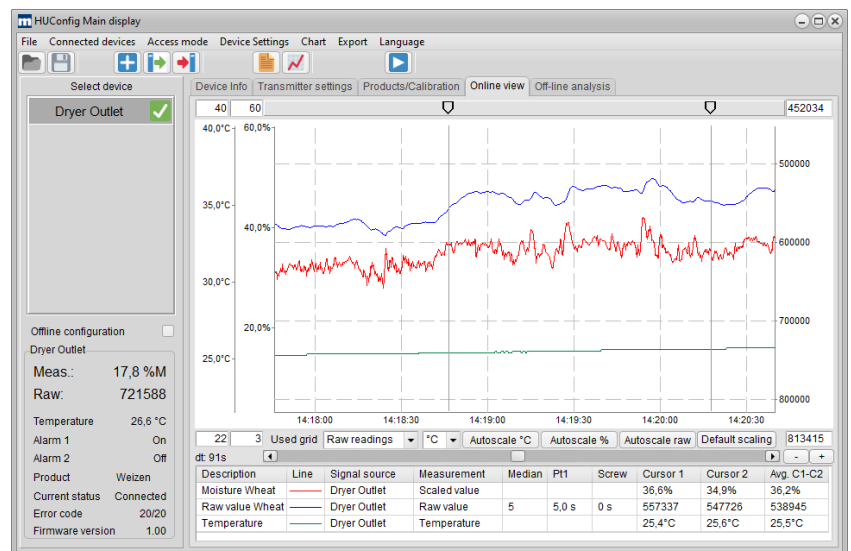

Properties

The sensor of the HUMY 301 is very robust and can be used flexibly. Sensor surfaces made of POM, Teflon and ceramic are available to process abrasive or aggressive materials. A high temperature option and an ATEX option for Zone 20 or Zone 0 are available. The device is equipped with an analog output and an RS485 Modbus interface. Windows software is used for calibration and analysis. Up to 24 calibration data sets can be stored, sixteen of which can be selected directly via digital inputs.

The HUMY is optimized for reliability and a long service life. Each sensor is sealed and tested under extreme temperatures. A self-monitoring function continuously checks the functionality of the device. It is therefore not surprising that HUMYs are used in extreme environments, e.g. in vibration channels.

Successful installations (excerpt)



Wheat / Maize

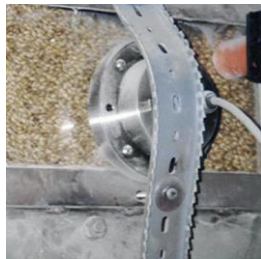

Malt



Sugar beet



Gelatine



Milk powder



Animal feed



Cement



Sand



Limestone



Fertilizer



Wood pellets



Cellulose



Plastic pellets



Coal and coke



Aluminum oxide

Technical data sensor

Stainless steel housing material	(1.4301 or 1.4307 as an option)
Surface of the sensor	K = POM C = Ceramic (optional) T = Teflon (optional) S = Ceramic+Teflon (optional)
Environment Temperature	0°C to +70°C (K/C version) 0°C to +80°C (T/S version)
Process temperature	0°C to +90°C (non-ATEX) 0°C to +120°C (non-ATEX with high temperature option) 0°C to +70°C (ATEX with K/C) 0°C to +90°C (ATEX with T/S)
Process pressure	6 bar (temporarily 10 bar)
Protection class	IP67
Outputs	RS485 for connection with the transmitter
Length of the cable	Shielded 4-pole cable, 3 meters as standard, lengths up to 500 meters on Request
Dimensions and Weight	T100 mm x 51.5 mm, 1300 g

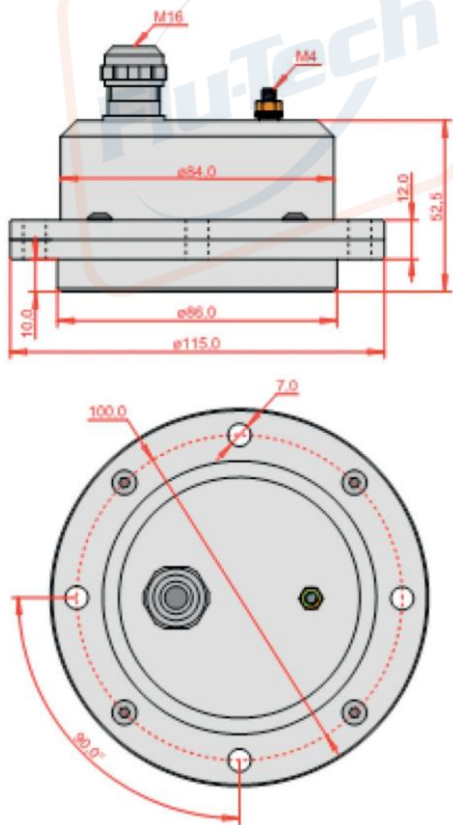

Technical data transmitter

Measured Moisture	0-85 % residual moisture or 15-100 % dry matter (TR)
Accuracy	Up to 0.1 % (depending on product)
Calibration can be saved	Up to 24 calibration curves
Supply voltage	24 VDC with +/- 25 %; max. 1.5 W
Inputs	1x RS485 (from FMS 410 sensor), 4x digital input (8 - 36 VDC; 2 - 14 mA)
Outputs	1x analog output for humidity value (0/4-20 mA; 0-10 V), 1x transistor output for various alarm values 1x relay output for various alarm values 1x USB 2.0 for programming 1x RS485 with MODBUS-Protocol for connection to a PLC
Electrical connection	TE-1 to TE-24: Screw-/Plug connection with 2.5 mm ² TE-B1 to TE-B5: TBUS-connection with 2.5 mm ²
Dimensions and weight	22.5 x 114.5 x 99 mm without clamps; 250 g

