

Operating instructions

FSI410iD FMS410iD-*

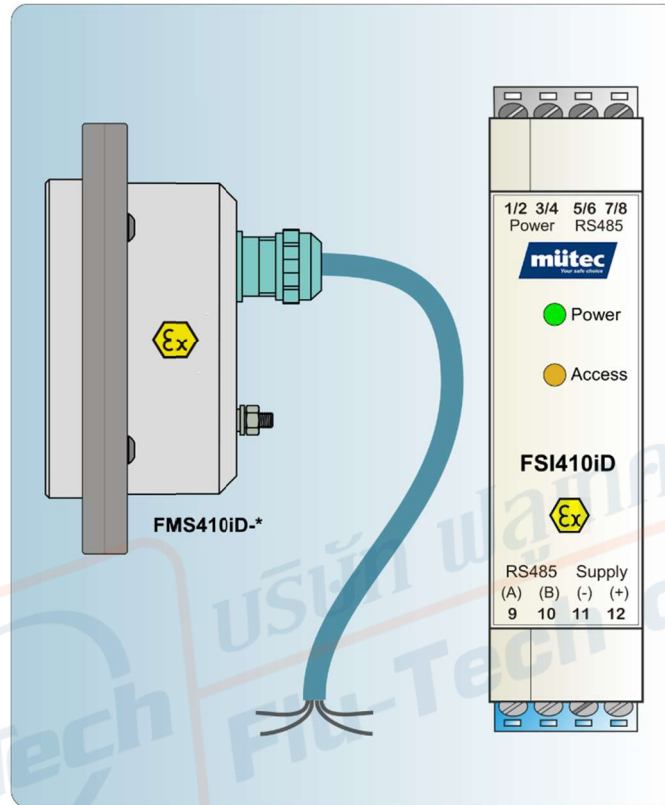

Variants:

- Moisture sensor **FMS410iD-K** Sensor in POM cup with POM measuring orifice plate
- Moisture sensor **FMS410iD-C** Sensor in POM cup with ceramic measuring orifice plate
- Moisture sensor **FMS410iD-T** Sensor in Teflon cup with PTFE measuring orifice plate
- Moisture sensor **FMS410iD-S** Sensor in Teflon cup with ceramic measuring orifice plate

Operating instructions for:

Moisture sensor interface FSI410iD

Moisture sensor FMS410iD-*

Publication no.: BA 332

Issue date: 2/2024

Manufacturer:

Mütec Instruments GmbH
Bei den Kämpen 26
21220 Seevetal
Germany

Tel: +49 (0) 4185 8083-0

Fax: +49 (0) 4185 808380

e-mail: info@muetec.deInternet: www.muetec.de**License, trademark and copyright notices**

Modbus™ is a registered trademark of Modicon Inc.

Windows™ is a registered trademark of Microsoft Corp.

Copyright © Mütec Instruments GmbH 2024 All rights reserved

This document is protected by copyright. It supports the user in the safe and efficient use of the device. This document may not be passed on or reproduced, nor may its contents be utilized or communicated, unless expressly permitted. Infringements will result in compensation for damages. The software described in this document is licensed and may only be used and copied in accordance with the license conditions.
All rights reserved.

Disclaimer

We have checked the contents of this publication for conformity with the hardware and software described. However, deviations cannot be ruled out, so that we cannot guarantee complete conformity. The information in this publication is checked regularly. Corrections and additions will be made in the following version. We are grateful for any suggestions for improvement.

Subject to technical changes

Table of Contents

Table of contents	3
Safety regulations and installation instructions.....	4
Classification of the safety instructions	5
General information	6
1 General information for installation and operation	7
2 ATEX relevant data	9
3 Technical data of the moisture sensor interface.....	11
4 Technical data of the moisture sensors	12
5 Block diagram of the FSI410iD with FMS410iD-*	14
6 Block diagram of the FSI410iD in the field housing FGA160 with FMS410iD-*	14
7 Terminal assignment of the FSI410iD in the FGA160 field housing	14
8 Cable connection of the moisture sensor FMS410iD-*	15
9 Field housing FGA160 with FSI410iD	15
10 Type plates of the moisture sensors FMS410iD-*	16

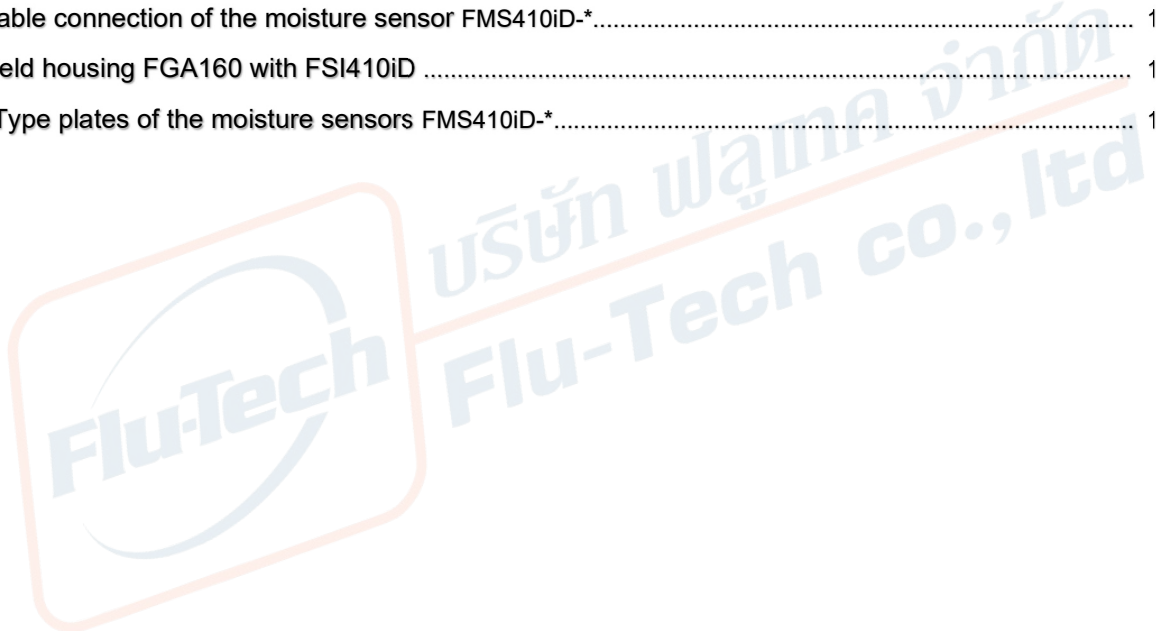

Safety regulations and instructions

Follow the instructions for installation:



Note: Installation, operation and maintenance may only be carried out by qualified personnel.

The applicable safety guidelines (including the national safety guidelines), accident prevention regulations and general technical regulations must be observed when installing and operating the appliance.



Note: The circuits in the appliance must not be accessed.

Do not repair the appliance yourself, but replace it with an equivalent appliance. Repairs may only be carried out by the manufacturer.



Note: The device is suitable for protection class IP20 if:

- It is installed outside potentially explosive atmospheres
- The environment is clean and dry

Install the device in a suitable housing with a suitable degree of protection in accordance with IEC/EN 60079-0 to protect it from mechanical and electrical damage.

The safety-relevant data can be found in the operating instructions and in the ATEX certificate (EU type examination certificate or other certificates, if necessary).

Safety regulations for installation in potentially explosive atmospheres and Regulations for intrinsically safe circuits:



Warning: Explosion hazard

When carrying out measurements on the intrinsically safe side, the relevant regulations regarding the connection of intrinsically safe electrical equipment must be observed.

Only use approved devices for use in intrinsically safe circuits.



Warning: Explosion hazard

If the device has previously been used in non-intrinsically safe circuits, it must not be used for intrinsically safe circuits may no longer be used.

Clearly mark the device as no longer intrinsically safe.

Installation in areas with a risk of dust explosions:



Warning: Explosion hazard

The appliance is not approved for installation in areas where there is a risk of dust explosions.

Only interconnect intrinsically safe circuits in potentially explosive dust in zones 20, 21 or 22 if the equipment connected to these circuits is approved for this zone (e.g. category 1D, 2D or 3D).

Classification of the instructions

This manual contains instructions that you must observe for your personal safety and to prevent damage to property. The instructions are highlighted by a warning triangle and shown as follows, depending on the degree of danger.



DANGER

means that death or serious bodily injury will occur, if the appropriate precautions are not taken.



WARNING

means that death or serious bodily injury may occur, if the appropriate precautions are not taken.



CAUTION

with a warning triangle means that minor bodily injury may occur, if the appropriate precautions are not taken.

CAUTION

without a warning triangle means that material damage may occur, if the appropriate precautions are not taken.



ATTENTION

means that an undesirable result or condition may occur, if the corresponding notice is not observed.



NOTE

is important information about the product, the handling of the product or the part of the documentation to which particular attention is drawn. and compliance with which is recommended.

In addition to these instructions in this publication, the generally applicable safety and accident prevention regulations must be observed.

If the information contained in this brochure is not sufficient in any case, our telephone service is at your disposal for further information.

Please read this document carefully before installation and commissioning.

CE mark

This product complies with the specifications of the EMC Directive 2014/30/EU and the Low Voltage Directive 2014/35/EU.

General information

This appliance has left the factory in a technically safe condition. In order to maintain this condition and to ensure safe operation of the appliance, the instructions and warnings given in these operating instructions must be observed by the user.

ATTENTION

For reasons of clarity, these instructions do not contain all detailed information on all types of the product and cannot take into account every conceivable case of installation, operation or maintenance.

Should you require further information, or should particular problems arise that are not covered in sufficient detail in the instructions, you can request the necessary information by telephone.

Furthermore, we would like to point out that the contents of the instructions are not part of a previous or existing agreement, promise or legal relationship or are intended to change these. All obligations of Mütec Instruments GmbH arise from the respective purchase contract, which also contains the complete and solely valid warranty provisions. These contractual warranty provisions are neither extended nor limited by the explanations in the instructions.

The content reflects the technical status at the time of printing. We reserve the right to make technical changes in the course of further development.

WARNING

Devices with the "intrinsic safety" type of protection lose their approval as soon as they are operated on circuits that do not comply with the values specified in the test certificate. The correct and safe operation of this appliance requires proper transportation, storage, installation and assembly as well as careful operation and maintenance. The appliance may only be used for the purposes specified in these operating instructions.

DISCLAIMER

All modifications to the appliance, unless expressly mentioned in the operating instructions, are the responsibility of the user.

Qualified PERSONNEL

are persons who are familiar with the installation, assembly, commissioning and operation of the product and who have the appropriate qualifications for their work, e.g:

- Training or instruction or authorization to operate and maintain devices/systems in accordance with the safety engineering standard for electrical circuits, high pressures and aggressive and hazardous media.
- For devices with explosion protection: training or instruction or authorization to carry out work on electrical circuits for potentially explosive systems.
- Training or instruction according to the standard of safety engineering in the care and use of appropriate safety equipment.

CAUTION

Electrostatic sensitive modules can be destroyed by voltages that are far below the threshold of human perception. These voltages already occur when you touch a component or electrical connections of an assembly without being electrostatically discharged. The damage that occurs to a module due to an overvoltage cannot usually be detected immediately, but only becomes noticeable after a long period of operation



1 General information for installation and operation

Labeling according to Directive 2014/34/EU:

Checkpoint	0158		II (2) G
Device group			
Associated equipment with external circuits for connection to category 2 devices for explosive mixtures of air and flammable substances Gases, vapors or mists			

Marking of the type of protection:

	[Ex ia Ga] IIC
associated electrical operating Medium according to European standard	
Type of protection	
EPL (Equipment Protection Level)	
Equipment group	

Safety instructions

The interface or the measuring sensor must be taken out of operation and secured against unintentional operation if it must be assumed that safe operation is no longer possible. Reasons for this assumption may be

- Visible damage to the device
- Failure of the electrical function
- Longer storage at temperatures above 85 °C
- Heavy transportation stress

Before the appliance is put back into operation, a professional routine test must be carried out in accordance with DIN EN 61010, Part 1. This test should always be carried out by the manufacturer. Repair work on Ex devices may only be carried out in accordance with §9 of the Ex Ordinance (Elex V).

Devices with intrinsically safe circuits must never be operated on non-intrinsically safe circuits. If Ex devices are to be operated on non-intrinsically safe circuits, they must be specially labeled and the Ex markings must be removed so that these devices are not used for intrinsically safe circuits at a later date. Subsequent testing of the devices for compliance with the conditions for explosion protection is only possible at a disproportionately high cost, even for the manufacturer, and is therefore generally rejected.

Intended use

The FSI410iD moisture sensor interface is used for the intrinsically safe supply and intrinsically safe interface connection to the FMS410iD-* moisture sensor.

The power supply circuit at terminals KT11 + KT12 and the RS485 interface at terminals KT 9 + KT10 of the top-hat rail housing comply with the "intrinsic safety" type of protection of category "ia".

The maximum ambient temperature range of -20 °C to +60 °C must not be exceeded or undershot.

The FSI410iD moisture sensor interface, optionally also installed in a field housing (FGA160), is an associated piece of electrical equipment with circuits of ignition protection type Ex ia IIC and must always be operated outside potentially explosive atmospheres. Only the intrinsically safe supply or interface circuit may be routed into the potentially explosive area and connected to the FMS410iD-* moisture sensor. Before commissioning, the correct connection of the intrinsically safe circuits to the FMS410iD-* must be checked.

The FMS410iD-* moisture sensor is used for inline measurement of the relative product moisture in bulk materials and solids. It may be operated as safe equipment in areas up to zone 20.

Installation and commissioning

The FSI410iD moisture sensor interface must be installed in such a way that the clearances from bare parts of intrinsically safe circuits to metallic housing parts are at least 3 mm and to the bare parts of non-intrinsically safe circuits at least 6 mm.

Connecting parts for the external intrinsically safe circuits must be arranged in such a way that the bare parts are at least 50 mm away from connecting parts or bare conductors of non-intrinsically safe circuits in accordance with section 6.2.1 of EN 60079-11.

The terminal assignment of the FSI410iD DIN rail housing with the intrinsically safe and non-intrinsically safe circuits is clearly marked on the type plate. In addition, the 4-pole terminals of the intrinsically safe circuits are blue.

In the FGA160 field housing, the terminal compartment is divided by a partition wall into an area for the intrinsically safe and non-intrinsically safe connections.



For safe operation of the FMS410D-*, it is strongly recommended that it is firmly connected to the equipotential bonding system by means of a protective conductor connection to the marked 4 mm threaded bolt on the rear of the sensor housing.

The solid screw connection enables the connection of cable cross-sections up to a maximum of 4 mm² with an appropriate cable lug.

Assembly/disassembly, installation, operation and maintenance may only be carried out by qualified personnel in the sense of the automation industry in compliance with the relevant regulations and these operating instructions. During installation, the technical data and the value of the supply voltage for the FSI410iD must be observed.

2 ATEX relevant data

Moisture sensor interface FSI410iD

Certificate	IBExU 18 ATEX 1064 Edition 1			
		II (1)G [Ex ia] IIC		
		II (1)D [Ex ia] IIIC Da		
Conformity	EN IEC 60079-0:2018	General requirements		
	EN 60079-11:2012	Intrinsic safety "I"		
Supply circuit (terminals 1/2 and 3/4)				
Rated voltage		DC	18 ... 30	V
max. voltage	To	AC	250	V
RS485 interface circuit (terminals 5/6 and 7/8)				
Rated voltage		DC	6	V
Rated current			100	mA
max. voltage	To	DC	48	V
Intrinsically safe output circuit (terminals 11 and 12)				
Tension	U _o	DC	19,4	V
Amperage	I _o			81
mA				
power (trapezoidal characteristic curve)	P _o		712	mW
internal capacitance to GND	C _{GND}		56	nF
Perm. external capacity	C _o		84	nF
Perm. external inductance	L _o		260	µH
Intrinsically safe interface circuit (terminals 9 and 10)				
Tension	U _o	DC	7,2	V
Amperage	I _o		77	mA
Power (trapezoidal characteristic curve)	P _o		147	mW
Perm. external capacity	C _o		84	nF
Perm. external inductance	L _o		300	µH
Ambient temperature range	T _{amb}		-20 °C to +60 °C	

Moisture sensor FMS410iD-K

Ex certificate	IBExU 18 ATEX 1064 Edition 1			
		II 1G Ex ia IIC T6 Ga		
		II 1D Ex ia IIIC T80 °C Da		
		0 °C ≤ Ta ≤ +70 °C		
Conformity	EN IEC 60079-0:2018	General requirements		
	EN 60079-11:2012	Intrinsic safety "I"		
Intrinsically safe supply circuit cable core 3(+) and 4(-)				
Tension	U _i	DC	19,4	V
Amperage	I _i		81	mA
Performance	P _i		712	mW
Effective internal capacity	C _i		160	pF/m
Effective internal inductance	L _i		520	nH/m
Intrinsically safe interface circuit (cable core 1(B) and 2(A))				
Tension	U _i	DC	7,3	V
Amperage	I _i		86	mA
Performance	P _i		199	mW
Effective internal capacity	C _i		160	pF/m
effective internal inductance	L _i		520	nH/m

Ambient temperature range	$T_{(amb)ient}$	0 °C to +70 °C
Process temperature range	$T_{processt}$	0 °C to +70 °C

Moisture sensor FMS410iD-C

Ex certificate IBExU 18 ATEX 1064 Edition 1

II 1G Ex ia IIB T6 Ga



II 2G Ex ia IIC T6 Gb

II 1D Ex ia IIIC T80 °C Da

0 °C ≤ Ta ≤ +70 °C

Conformity EN IEC 60079-0:2018 General requirements
EN 60079-11:2012 Intrinsic safety "i"

Intrinsically safe supply circuit (cable core 3(+) and 4(-))

Tension	U_i	DC	19,4	V
Amperage	I_i		81	mA
Performance	P_i		712	mW
Effective internal capacity	C_i		160	pF/m
effective internal inductance	L_i		520	nH/m

Intrinsically safe interface circuit (cable core 1(B) and 2(A))

Tension	U_i	DC	7,3	V
Amperage	I_i		86	mA
Performance	P_i		199	mW
Effective internal capacity	C_i		160	pF/m
effective internal inductance	L_i		520	nH/m

Ambient temperature range	$T_{ambient}$	0 °C to +70 °C
Process temperature range	$T_{processt}$	0 °C to +70 °C

Moisture sensors FMS410iD-T and FMS410iD-S

Ex certificate IBExU 18 ATEX 1064 Edition 1

II 1G Ex ia IIB T4 Ga



II 2G Ex ia IIC T4 Gb

II 1D Ex ia IIIC T135 °C Da

0 °C ≤ Ta ≤ +80 °C

Conformity EN IEC 60079-0:2018 General requirements
EN 60079-11:2012 Intrinsic safety "i"

Intrinsically safe supply circuit (cable core 3(+) and 4(-))

Tension	U_i	DC	19,4	V
Amperage	I_i		81	mA
Performance	P_i		712	mW
Effective internal capacity	C_i		160	pF/m
effective internal inductance	L_i		520	nH/m

Intrinsically safe interface circuit (cable core 1(B) and 2(A))

Tension	U_i	DC	7,3	V
Amperage	I_i		86	mA
Performance	P_i		199	mW
Effective internal capacity	C_i		160	pF/m
effective internal inductance	L_i		520	nH/m

Ambient temperature range	$T_{ambient}$	0 °C to +80 °C
Process temperature range	$T_{processt}$	0 °C to +90 °C

3 Technical data of the moisture sensor interface

Moisture sensor RS485 interface [Ex ia IIC]

Galvanic isolation from the power supply and all other inputs/outputs!

Protocol:	MODBUS, RTU mode
RS485:	Half-duplex, terminated
Baud rate:	19200 bps

Moisture sensor supply circuit [Ex ia IIC]

Galvanic isolation from the power supply and all other inputs/outputs!

DC supply:	20 V, 25 mA
------------	-------------

Auxiliary energy

Supply circuit:	24 VDC +/- 25 %
Power consumption:	max. 2 W

Conformity

Ex directive (ATEX):	EN IEC 60079-0:2018, EN 60079-11:2012
EMC Directive 2014/30/EU:	EN 61000-6-2, EN 61000-6-4, EN 61326-1

General data

Galvanic isolation

Input/output/ Supply:	300 Vrms (rated insulation voltage, overvoltage protection) Category II, pollution degree 2, safe isolation according to EN 61010, EN 50178); 2.5 kV AC test voltage (50 Hz, 1 min.);
Input/output:	375 V (peak value according to EN 60079-11)
Input/supply:	375 V (peak value according to EN 60079-11)

Electrical connection

KL-1 to KL-8:	Screw connector/gray with 2.5 mm ²
KL-B1 to KL-B5:	TBUS connector with 2.5 mm ²

Housing

Material:	PBT
Protection class:	IP20
Flammability class:	V0 according to UL
Dimensions (WxLxH):	22.5 mm x 114.5 mm x 99 mm without terminals
Weight:	250 g
Design:	Terminal housing for DIN rail mounting
Mounting/installation position:	any

Ambient conditions

Permissible temperature:	-20 °C ... +60 °C
Storage/transport:	-20 °C ... +70 °C
Perm. moisture during operation:	10 % ... 95 % r.h. without condensation

Assembly

The appliance may only be installed outside a potentially explosive atmosphere!

The ME-MAX housing can be combined with a 5-pin TBUS connector/ DIN rail connector. The RS485 interface and the supply voltage can be conveniently wired through via the TBUS connector snapped into the top-hat rail. The TBUS connection is set up automatically in the grid of the devices involved. Time-consuming pre-planning or reworking of the TBUS connection on site is therefore a thing of the past.

Technical data:

5-pin connector with 3.81 mm pitch; 8 A maximum contact load; high contact quality due to gold plating; Mounting in NS 35/7.5 or NS 35/15 top-hat rails;



Only snap device onto/from TBUS connector without power. Or separate them!

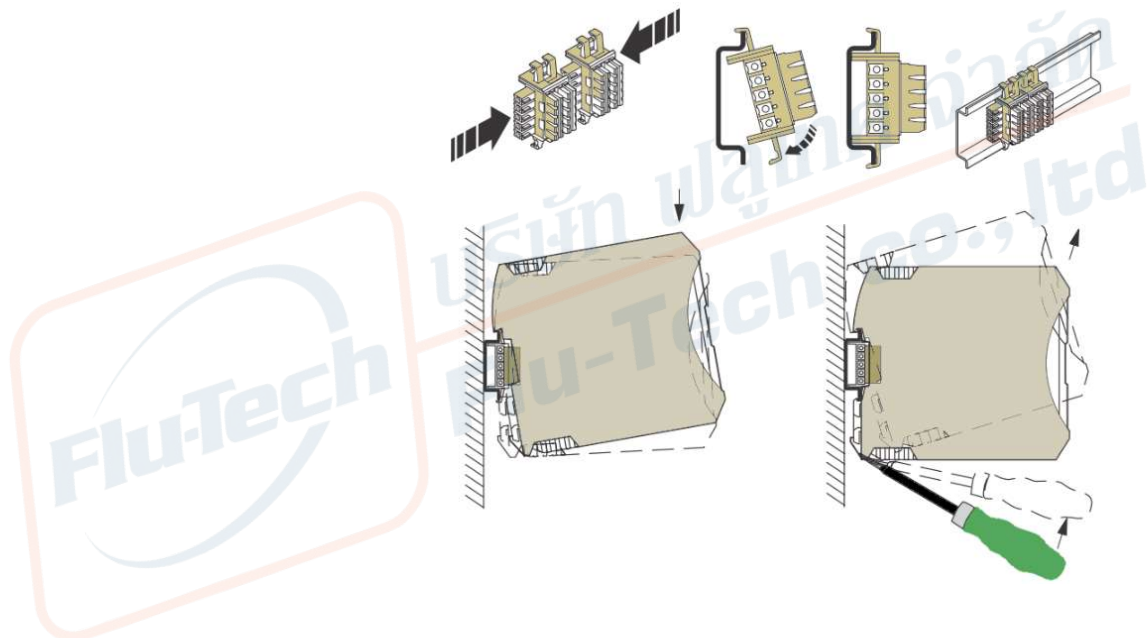

4 Technical data of the moisture sensors

Moisture sensor RS485 interface [Ex ia IIC]

Voltage:	< 20 V
Current:	< 50 mA
RS485 interface:	Half-duplex
Baud rate/device address:	19200 bps, 1
Power consumption:	≤ 500 mW

Mechanical data

Housing:	Stainless steel 1.4301
Protection class:	IP 67 according to EN 60529
Weight:	approx. 1050 g
Response time:	approx. 1 second
Connection cable:	Shielded cable, 4-core, min. 0.5 mm ²
Cable length:	as required up to max. 250 m

Material of the measuring surface

FMS410iD-K:	POM
FMS410iD-T:	PTFE
FMS410iD-C/S:	Ceramic

Limit values

Pressure resistance: min. 0.8 bar, max. 1.1 bar

FMS410iD-C and FMS410iD-K

Ambient temperature (housing): 0°C to +70°C

Process temperature (measuring orifice): 0°C to +70°C

FMS410iD-T and FMS410iD-S

Ambient temperature (housing): 0°C to +80°C

Process temperature (measuring orifice): 0°C to +90°C

Storage temperature: -10 to 80°C

Dimensions

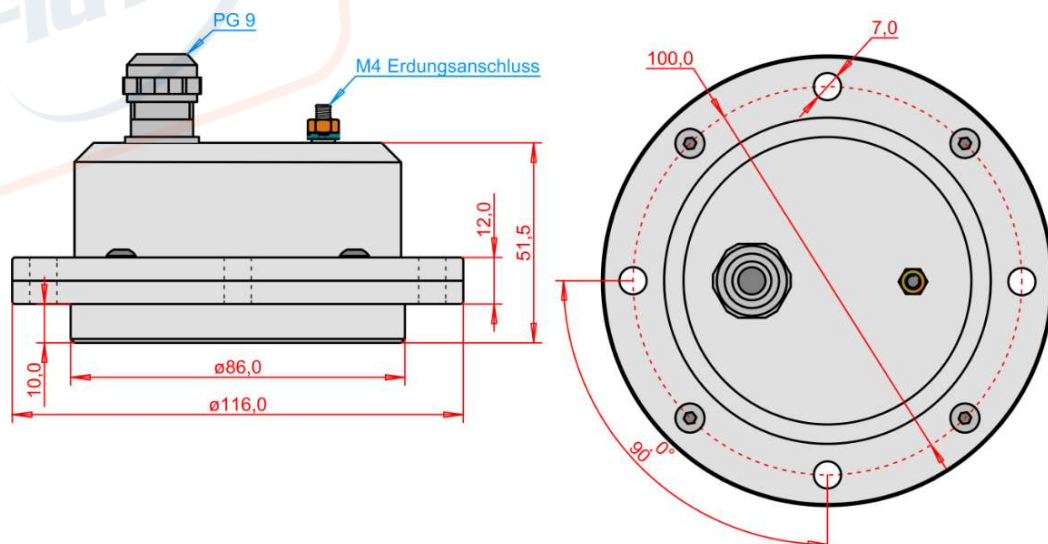

5 Block diagram of the FSI410iD with FMS410iD-*

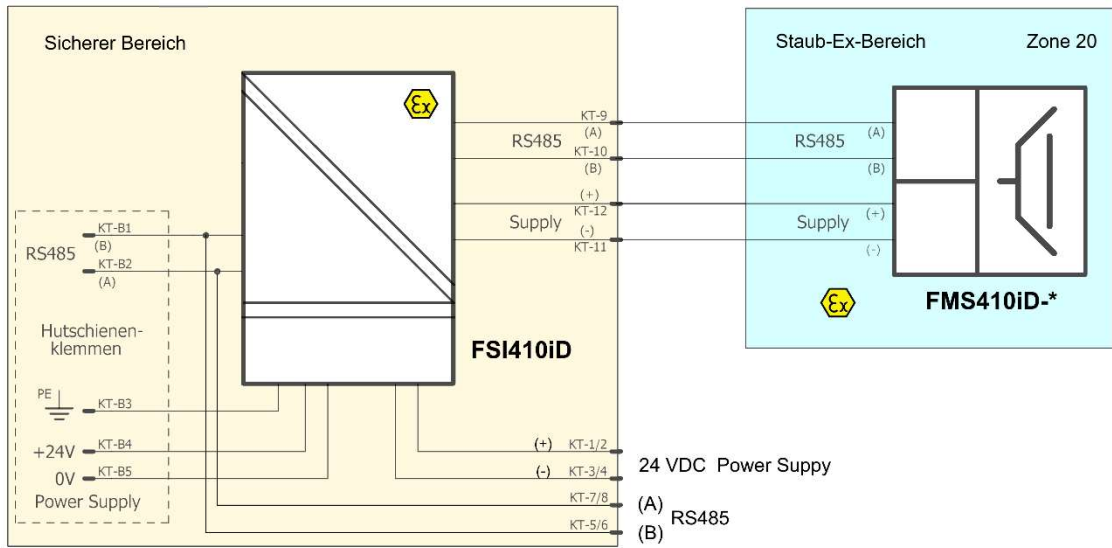

6 Block diagram of the FSI410iD in the FGA160 field housing with FMS410iD-*

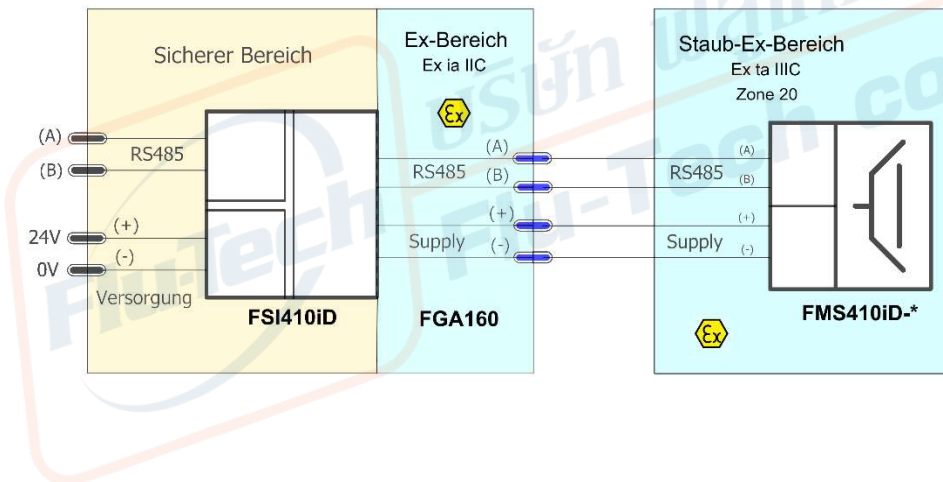

7 Terminal assignment of the FSI410iD in the field housing FGA160

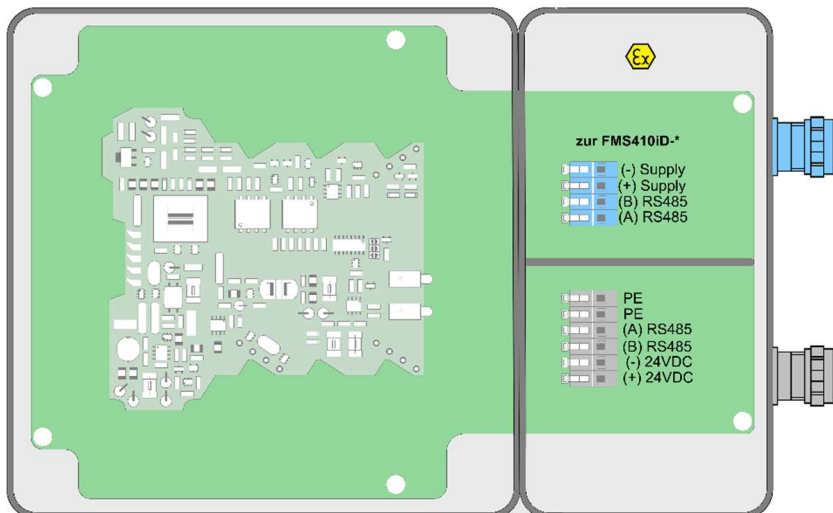

8 Cable connection of the FMS410iD-* moisture sensor

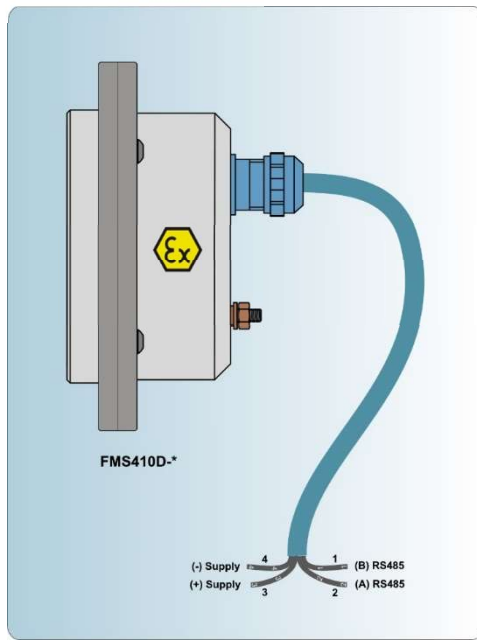

The cable shield is in the sensor closed at the earthing contact. If the cable shield is also earthed at the other end of the cable and there is a potential difference between the two earthing points, this can result in a more or less large equalizing current via the cable shield.

9 Field housing FGA160 with FSI410iD

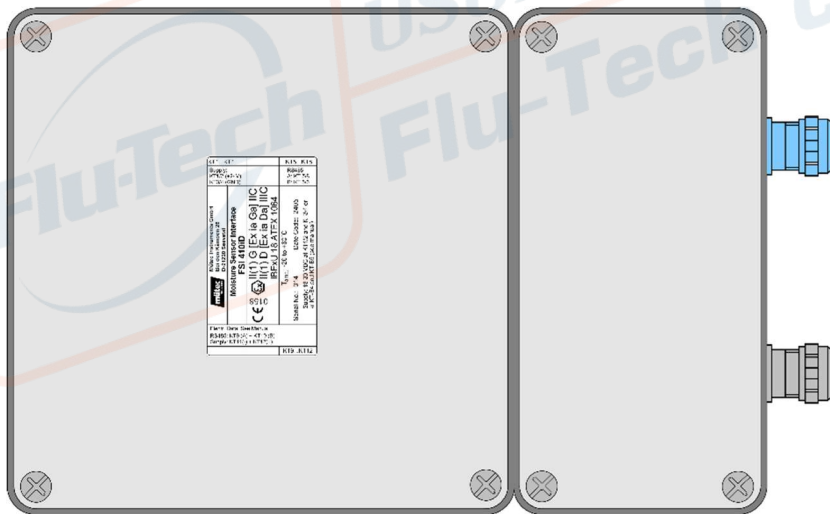

Dimensions (LxWxH):
240 x 160 x 103 mm

10 Type plates of the FMS410iD-* moisture sensors

 Mütec Instruments GmbH Bei den Kämpen 26 D-21220 Seevetal	
Type: FMS 410iD-C $T_{amb.}$: 0 to +70°C	
CE 0158  II 1 G Ex ia IIB T6 Ga II 2 G Ex ia IIC T6 Gb II 1 D Ex ia IIIC T80 °C Da IBExU 18 ATEX 1064	
Range: 580T to 750T Dgt. Temp.: 15°C to 45°C	Date.: 2404 SN: 131201

 Mütec Instruments GmbH Bei den Kämpen 26 D-21220 Seevetal	
Type: FMS 410iD-K $T_{amb.}$: 0 to +70°C	
CE 0158  II 1 G Ex ia IIC T6 Ga II 1 D Ex ia IIIC T80 °C Da IBExU 18 ATEX 1064	
Range: 580T to 750T Dgt. Temp.: 15°C to 45°C	Date.: 2404 SN: 131201

 Mütec Instruments GmbH Bei den Kämpen 26 D-21220 Seevetal	
Type: FMS 410iD-S $T_{amb.}$: 0 to +80°C, $T_{proc.}$: to +90°C	
CE 0158  II 1 G Ex ia IIB T4 Ga II 2 G Ex ia IIC T4 Gb II 1 D Ex ia IIIC T135 °C Da IBExU 18 ATEX 1064	
Range: 580T to 750T Dgt. Temp.: 15°C to 45°C	Date.: 2404 SN: 131201

 Mütec Instruments GmbH Bei den Kämpen 26 D-21220 Seevetal	
Type: FMS 410iD-T $T_{amb.}$: 0 to +80°C, $T_{proc.}$: to +90°C	
CE 0158  II 1 G Ex ia IIB T4 Ga II 2 G Ex ia IIC T4 Gb II 1 D Ex ia IIIC T135 °C Da IBExU 18 ATEX 1064	
Range: 580T to 750T Dgt. Temp.: 15°C to 45°C	Date.: 2404 SN: 131202
TAG No.:	

