

OPERATING AND MAINTENANCE MANUAL

TRANSMITTER WITH DISPLAY

SE 56

MAN 1000185580 ML Version: B Status: RL (released | freigegeben) printed: 11.09.2025



Release number: MASE56_DisplayFlow_EN_BU_R10_3.91.0XXX.docx – The characters of file name in bolt type indicate the software version which the manual refers to; it is visualized at the instrument start up, or by specific function on DIAGNOSTIC menu.



Email: sales@flutech.co.th Website: <https://flutech.co.th>

Tel: 02-384-6060, 086-369-5871-3 Fax: 02-384-5701 LINE OA: @flutech.co.th

Address (HQ): 845/3-4, Moo 3, Theparak Rd., T. Theparak, A. Mueang Samut Prakan, Samut Prakan, 10270, Thailand

INDEX

Introduction	4
Safety informations	4
Safety conventions	5
Technical characteristics	6
Electric characteristics	6
Environmental use conditions	6
Ambient temperature	6
Flame plate	6
Overall dimensions	7
Electrical connections	8
Grounding instructions	8
Transmitter power supply	8
Compact/wall-mount version M1 terminal block	9
Panel-mount version M1 terminal block	9
Transmitter to sensor electrical connections	10
Optional modules	11
Inputs/outputs	13
Digital input	13
Input operation stage (generic functions)	14
Operation stage on input 1 or 2 (batch function)	15
Operation stage on input 1 and 2 (batch function)	16
Output wirings	17
Transmitter access	18
Flags and led interpretation	18
Keyboard	19
Blind version	19
Start-up visualization pages	20
Low rate visualization	21
Access codes	22
Block dip-switch	22
Quick start menu	23
Access to the configuration menu	24
Examples	25
Configuration functions	27
Functions description	30
Batch function configuration	38
Alarm messages	40
Appendix: Display rotation procedure	41
Conformity declaration	42

INTRODUCTION

These operating instructions and description of device functions are provided as part of the scope of supply. They could be modified without prior notice. The improper use, possible tampering of the instrument or parts of it and substitutions of any components not original, renders the warranty automatically void.

The transmitter is to be used only to be coupled with a sensor device to realize a measuring device, flow meter, that is to be used for measuring the flow of conductive liquids in closed pipes with conductivity greater than $5\mu\text{S}/\text{cm}$.

The transmitter could be coupled directly on the sensor (compact version) or coupled to the sensor by cable supplied with it (remote version).

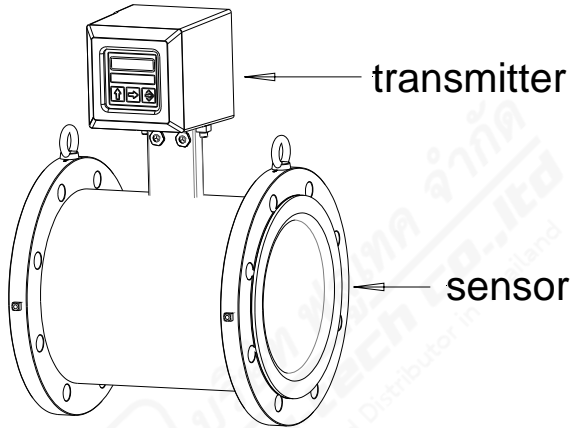

The reproduction of this manual and any supplied software is strictly forbidden.

SAFETY INFORMATIONS

Any use other than described in this manual affects the protection provided by the manufacturer and compromises the safety of people and the entire measuring system and is, therefore, not permitted.

The manufacturer is not liable for damaged caused by improper or non-designated use.

- 1) Transport the measuring device to the measuring point in the original packaging. Do not remove covers or caps until immediately before installation. In case of cartons packaging it is possible to place one above the other but no more than three cartons. In case of wooden packaging do not place one above the other.
- 2) Disposal of this product or parts of it must be carried out according to the local public or private waste collection service regulations.
- 3) The transmitter must only be installed, connected and maintained by qualified and authorized specialists (e.g. electrical technicians) in full compliance with the instructions in these Operating Instructions, the applicable norms, legal regulations and certificates (depending on the application).
- 4) The specialists must have read and understood these Operating Instructions and must follow the instructions it contains. The Operating Instructions provide detailed

1000185580 ML Version: B Status: RL (released | freigegeben)

information about the transmitter. If you are unclear on anything in these Operating Instructions, you must call the service.

- 5) The transmitter should only be installed after have verified technical data provided in these operating instructions and on the name plate.
- 6) Specialists must take care during installation and use personal protective equipment as provided by any related security plan or risk assessment.
- 7) Never mount or wire the transmitter while it is connected to the power supply and avoid any liquid contact with the instrument's internal components. To connect remove the terminals from the terminal block.
- 8) Before connecting the power supply check the functionality of the safety equipment.
- 9) Repairs may only be performed if a genuine spare parts kit is available and this repair work is expressly permitted.
- 10) For the cleaning of the device use only a damp cloth, and for the maintenance/repairs contact the service center.

Before starting up the equipment please verify the following:

- Power supply voltage must correspond to that specified on the name plate
- Electric connections must be completed as described
- Ground (earth) connections must be completed as specified

Verify periodically (every 3-4 months):

- The power supply cables integrity, wiring and other connected electrical parts
- The transmitter housing integrity
- The suitable tightness of the sealing elements
- The front panel integrity (display and keyboard)
- The mechanical fixing of the transmitter to the pipe or wall stand.

SAFETY CONVENTIONS



DANGER

Warning indicates an action or procedure which, if not performed correctly, can result in injury or a safety hazard. Comply strictly with the instructions and proceed with care.



WARNING

Caution indicates an action or procedure which, if not performed correctly, can result in incorrect operation or destruction of the device. Comply strictly with the instructions.



NOTES

Note indicates an action or procedure which, if not performed correctly, can have an indirect effect on operation or trigger an unexpected response on the part of the device.

TECHNICAL CHARACTERISTICS



ELECTRIC CHARACTERISTICS

Instrument classification: class I, IP67 for compact/wall-mount version, IP54 for panel-mount version (IP65 with optional transparent frontal cover), installation category II, rated pollution degree 2.

Power supply versions	Power supply voltage	Power supply frequency	Pmax
HV	100-240V AC	44-66Hz	25VA
LV	18-45V AC		
	LLV	18-45V DC	//
10-35V DC			

- Voltage variations must not exceed $\pm 10\%$ of the nominal one.
- All instrument versions can be equipped with all power supply versions.
- Input/output are insulated up to 500V.
- The output 4-20 mA (optional) and the output 24V DC are electrically connected.



ENVIRONMENTAL USE CONDITIONS

- The instrument can be installed inside or outside buildings
- Altitude: from -200m to 2000m (from -656 to 6560 feet)
- Humidity range: 0-100% (IP 67), 0-90% without condensation (IP54) for panel-mount version

AMBIENT TEMPERATURE

	Min. *	Max
°C	-20	60
°F	-4	140

If the transmitter is supplied in compact version to the sensor, consider the ambient temperatures more restrictive, otherwise refer to the respective manuals.

* For discontinuous use, a thermostat heat source installation may be necessary.

Name plate

On the name plate there is some technical information:

- **MODEL:** Transmitter Model
- **SERIAL N:** Serial Number of the transmitter
- **P.S.:** Power Supply
- **POWER:** Maximum power consumption
- **HZ:** Frequency (AC)
- **T:** Ambient temperature, device active
- **IP:** Protection grade
- **COUPLING:** Serial number of sensor coupled
- **ITEM:** free for user

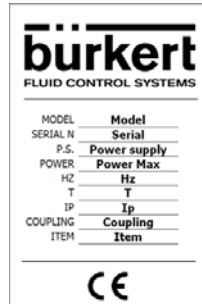

OVERALL DIMENSIONS

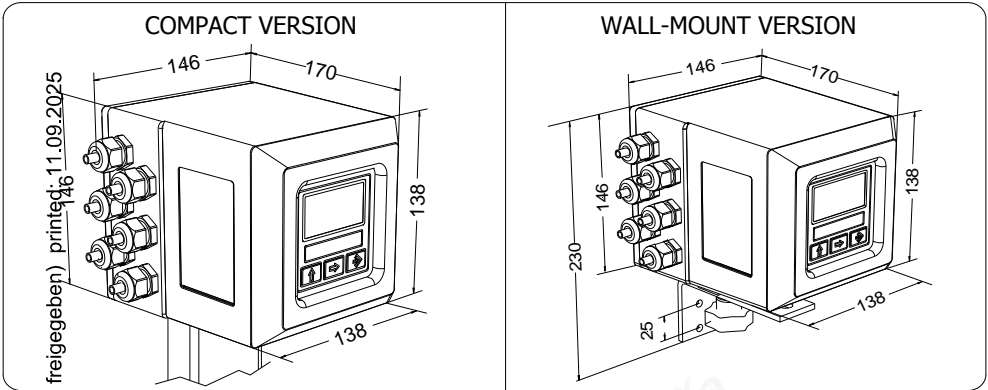

WEIGHT

	Compact	Wall-mount
INOX AISI 304	3kg	3.5kg
Alluminium	2.5kg	3kg

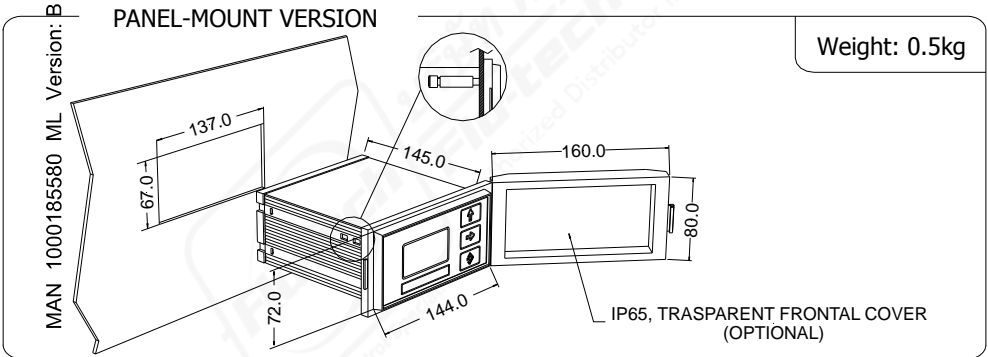

TORQUES

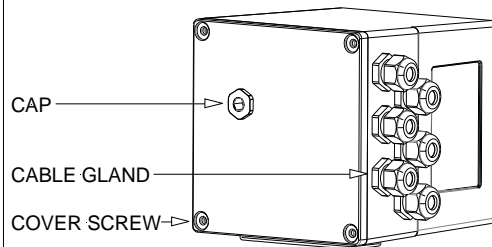

To guarantee the compact/wall-mount housing's IP degree the following torques are required:

- cover screws: 1.5Nm
- cable glands: 4Nm (in reference conditions)
- cap: 4Nm

ELECTRICAL CONNECTIONS

GROUNDING INSTRUCTIONS



ALWAYS ensure that the transmitter and the sensor are grounded (earthed) correctly. The grounding of the sensor and transmitter ensures that the equipment and liquid are equipotential.

MAN 1000185580 ML Version: B Status: RL (released | freigegeben) | printed: 10081525



TRANSMITTER POWER SUPPLY

Compact/wall-mount

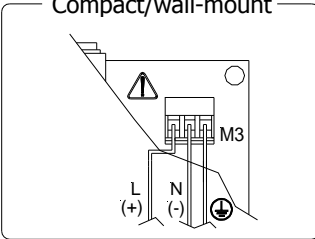

Panel-mount

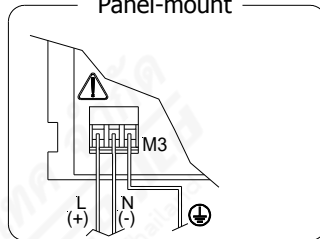

- Before connecting the power supply, verify that the mains voltage is within the limits indicated on name plate.
- For the connections use only approved conductors, with fire-proof properties, whose section varies from 0.25mm² to 2.50mm², based on distance/power; additionally fix the power supply wires with a additional fastening system located close to the terminal.
- The power supply line must be equipped with an external protection for overload current (fuse or automatic line breaker).
- Provide close to the transmitter a circuit breaker easily accessible for the operator and clearly identified; whose symbols must conform to the electrical safety and local electrical requirements.
- Ensure that the component complies with the requirements of the standard for electrical safety distance.
- Check chemical compatibility of materials used in the connection security systems in order to minimize electrochemical corrosion.
- The sensor, hardwired inputs and outputs are connected to the transmitter through a terminal blocks located inside the transmitter.
- To locate the compact/wall-mounted version terminal block loosen the 4 screws on the rear cover. When the front cover is lifted, the terminal block is visible. The terminal block allows the hardwire connection of the transmitter to external equipment, including the sensor.

The following pages give informations on the terminal block numbering, and the respective connecting of the sensor cables, and inputs/outputs.

COMPACT/WALL-MOUNT VERSION M1 TERMINAL BLOCK

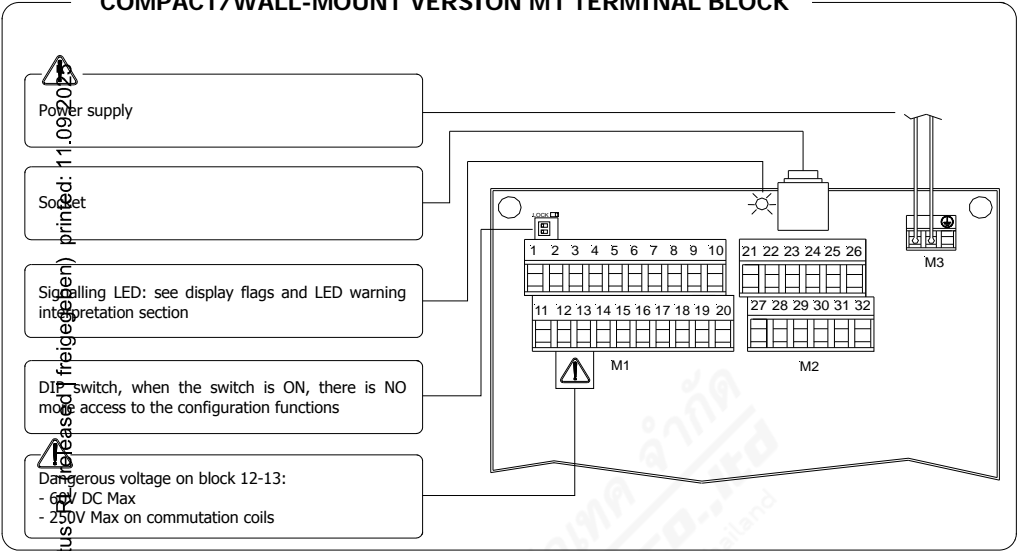

PANEL-MOUNT VERSION M1 TERMINAL BLOCK

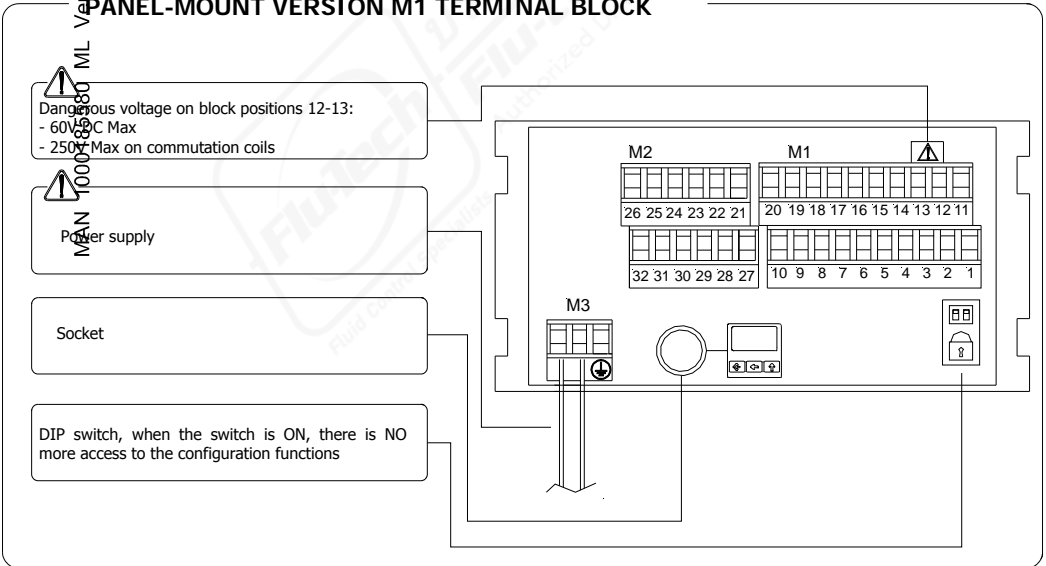

TRANSMITTER TO SENSOR ELECTRICAL CONNECTIONS

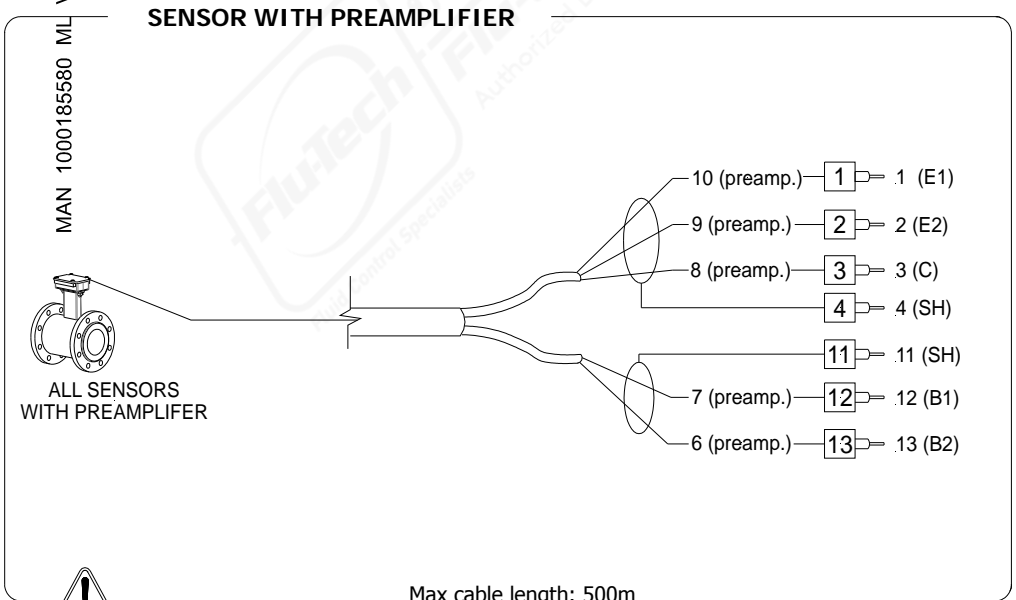
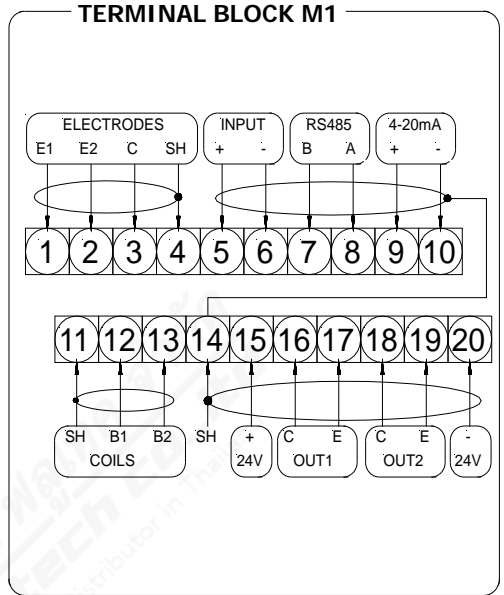
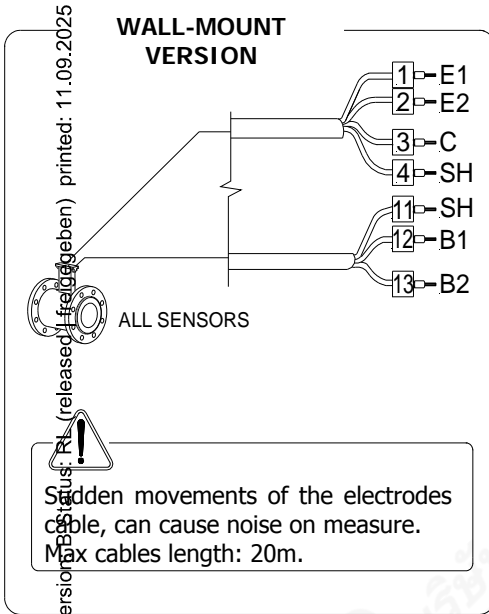

OPTIONAL MODULES

OPTIONAL MODULES (NO RELÈ MODULES)

- ❑ **ME200:** 2 configurable on/off outputs + 1 on/off input
- ❑ **ME201:** 1 configurable on/off output + 1 high frequency output + 1 on/off input
- ❑ **ME202:** 1 4-20mA output + 2 configurable on/off output + 1 on/off input
- ❑ **ME203:** 1 RS232 port + 2 configurable on/off outputs + 1 on/off input
- ❑ **ME204:** 1 RS232 port + 2 configurable on/off outputs + 1 4-20mA output + 1 on/off input
- ❑ **ME220, ME221, ME222:** data logger, see the related manual
- ❑ **PROFIBUS DP, HART and Modbus,** see the related manuals

LEGEND

- SH:** Cable shield, electrically connected to ground and to the housing
- CTS:** Input terminal of the signal "CLEAR TO SEND" of the RS232 port
- RD:** Input terminal of the signal "RECEIVE DATA" RS232 port
- TD:** Output terminal of the signal "TRANSMIT DATA" of the RS232 port
- SG:** Terminal "SIGNAL GROUND" common to all signals of the RS232 port
- C:** Terminal connected with the on/off output transistor COLLECTOR
- E:** Terminal connected with the on/off output transistor EMITTER

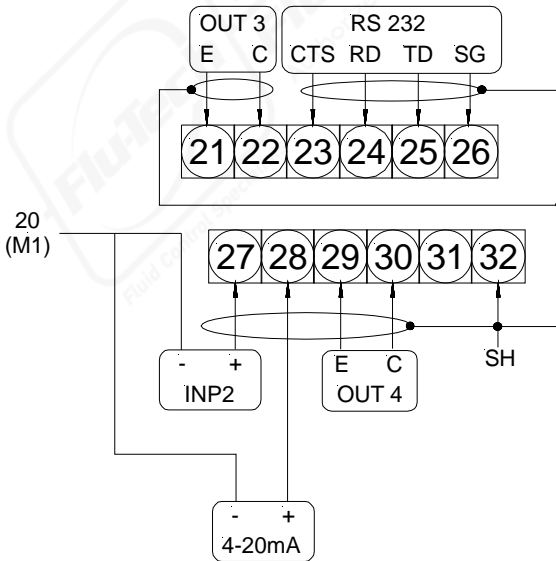

MAN 1000185580 ML Version: B Status: RL (released | freigegeben) printed: 11.09.2025

OPTIONAL RELÉ MODULES

LEGEND

MAN 1000185580 ML Version: B Status: RL (released | freigegeben) printed: 01.09.2025

ME205: 2 relay outputs with 1 NO contact + 1 NC contact each, 2A 60V AC, 60W/125VA

ME207: 2 relay outputs with 1 NO contact + 1 NC contact each, 2A 250V AC, 60W/125VA

- ❑ **SH:** Cable shield, electrically connected to ground and to the housing
- ❑ **C:** Relay – common
- ❑ **NC:** Normally closed contact
- ❑ **NO:** Normally open contact

Terminal block on compact/wall-mount version

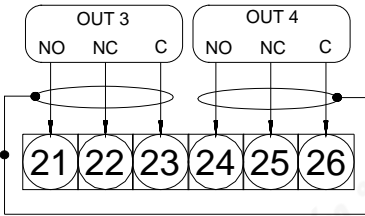

M2 position on compact/wall-mount version

Terminal block on panel-mount version

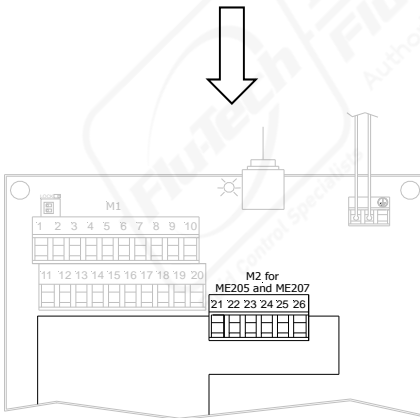
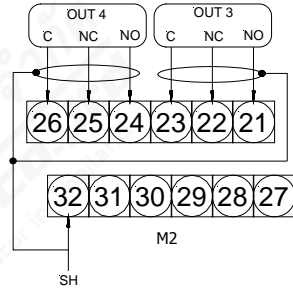

NOTE: On panel-mount version the terminal block **M2** is the same as with the other modules.

INPUTS/OUTPUTS

DIGITAL INPUT

External power supply

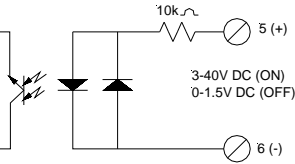

Internal power supply

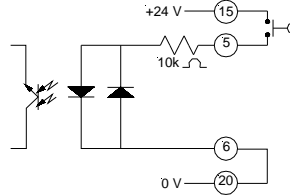

The functions referring to the inputs could be divided in three groups:

- 1) only assignable functions to the input 1
- 2) functions that act directly on the inputs independently from the select input
- 3) only assignable functions to the input 1 and only to the input 2 which interact between them

For details see the following pages.

Remember that the activation of any functions of batch automatically disable the other. The list of such functions is suitable in the table of the batch function configuration section.

MAN 1000185580 | freigegeben | printed: 11.09.2025 | Status: RL (released) | Version: B

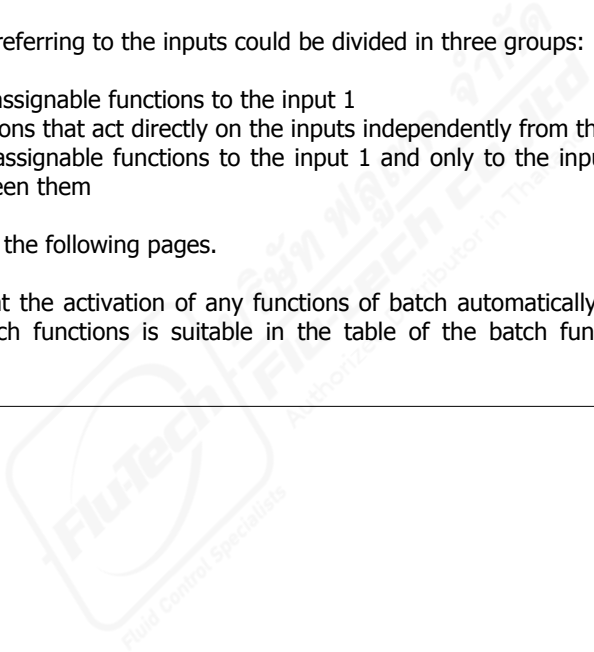

OPERATION ON INPUT ON/OFF INPUT OPERATION STAGE (GENERIC FUNCTIONS)

Auto-calibration

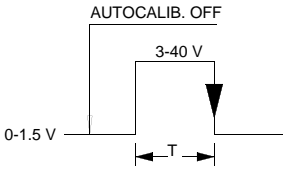

$T_{min} < T < 1sec.$ = autocalibration
 $T > 1 sec.$ = Auto zero

Necessary conditions for enabling the function

POS. 5.8 ENABLED (Autozero calibration external command)

POS. 5.10 DISABLED (batch on input 1)

POS. 5.11 DISABLED (batch functions assign to input 2 (optional))

Reset totalizers

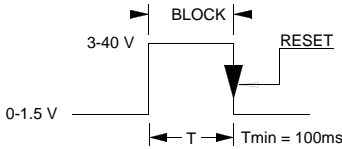

Necessary conditions for enabling the function

POS. 5.1 to 5.4 ENABLED (partial positive or reverse flow totalizers reset enable).

N.B.: This function is even assignable to the input 2

Block totalizers

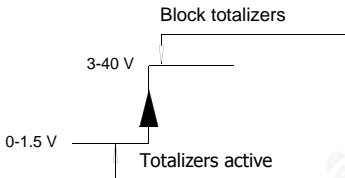

Necessary conditions for enabling the function

POS. 5.6 ENABLED (totalizers counting lock command)

POS. 12.5 DISABLED (auto-batch)

POS. 12.7 DISABLED (batch consent)

Range change

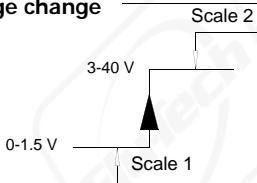

Necessary conditions for enabling the function

POS. 5.9 ENABLED (range change)

POS. 5.10 DISABLED (batch on input 1)

POS. 5.11 DISABLED (batch functions assign to input 2 (optional))

POS. 6.1-4 DISABLED (end-batch functions assign to output 2)

Measure lock

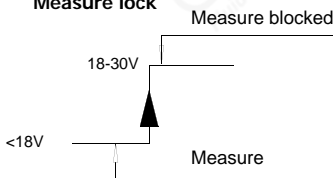

Necessary condition for enabling the function

POS. 5.7 ENABLED (measure lock)

Sample

Tmin

Sample	Tmin
10Hz	220ms
20Hz	110ms
50Hz	45ms
80Hz	30ms
150Hz	15ms



ATTENTION: time T must be \geq to Tmin



Note: THE FUNCTIONS ABOVE ARE ENABLED ONLY ON INPUT 1

OPERATION STAGE ON INPUT 1 OR 2 (BATCH FUNCTION)

Start batch from remote input

printed: 11.09.2025

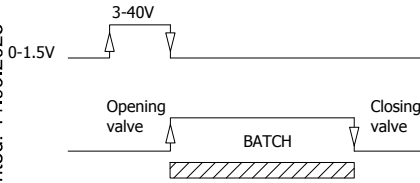

INPUT
OUTPUT

Necessary conditions for enabling the function

- POS. 5.10 or POS. 5.11 ENABLED on batch
- POS. 6.1 to 6.4 on end batch

Start batch from consent (remote)

freigegeben

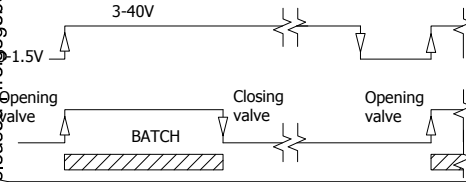

INPUT
OUTPUT

Necessary conditions for enabling the function

- POS. 5.10 ENABLED or POS. 5.11 on batch
- POS. 6.1 to 6.4 on batch
- POS. 12.7 ENABLED (Consent mode)

Start batch from remote input with auto-batch enabled

Version: B Status: RL

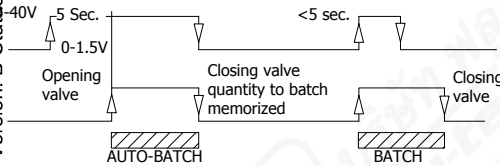

INPUT
OUTPUT

Necessary conditions for enabling the function

- POS. 5.10 or POS. 5.11 ENABLED on BATCH
- POS. 6.1 to 6.4 on END BATCH
- POS. 12.5 ENABLED (auto-batch)
- POS. 12.7 DISABLED (consent mode)

Start batch from remote input with automatic selection of formula 00/03

MAN 1000185580

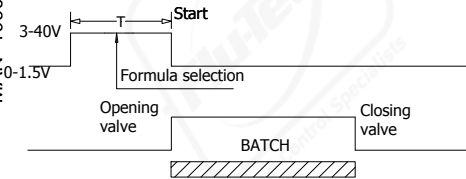

INPUT
OUTPUT

T= 100ms ±50ms for select the formula 00
T= 200ms ±50ms for select the formula 01
T= 300ms ±50ms for select the formula 02
T= 400ms ±50ms for select the formula 03
In case of stop batch from remote input the time of input

Necessary conditions for enable the function

- POS. 5.10 ENABLED on BATCH or POS.5.11
- POS. 6.1 to 6.4 on END BATCH
- POS. 12.6 ENABLED (automatic selection of formula)
- POS. 12.7 DISABLED (consent mode)
- POS. 5.11 DISABLED selection function for the formula 00/01 assigned to input 2 (optional)

Start batch from remote input 1 reset p+ enabled on remote input 1

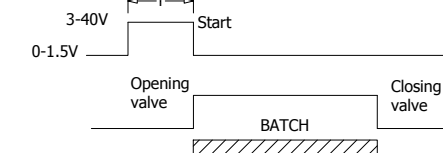

INPUT
OUTPUT

T BETWEEN 1 AND 4 = RESET TOTALIZER
T<1 = START AND RESET TOTALIZER

Necessary conditions for enabling the function

- POS. 5.10 ENABLED (Batch on input 1)
- POS. 6.1 - 6.4 on BATCH
- POS. 5.2 ENABLED (reset P+)



N.B.: THE ACTIVATION OF BATCH FUNCTIONS ON INPUT 2 PREVENTS THE ACTIVATION OF BATCH FUNCTIONS ON INPUT 1

OPERATION STAGE ON INPUT 1 AND 2 (BATCH FUNCTION)

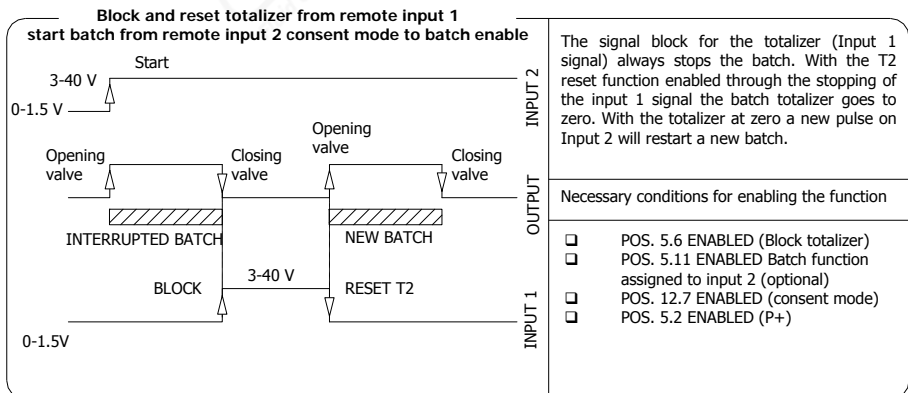
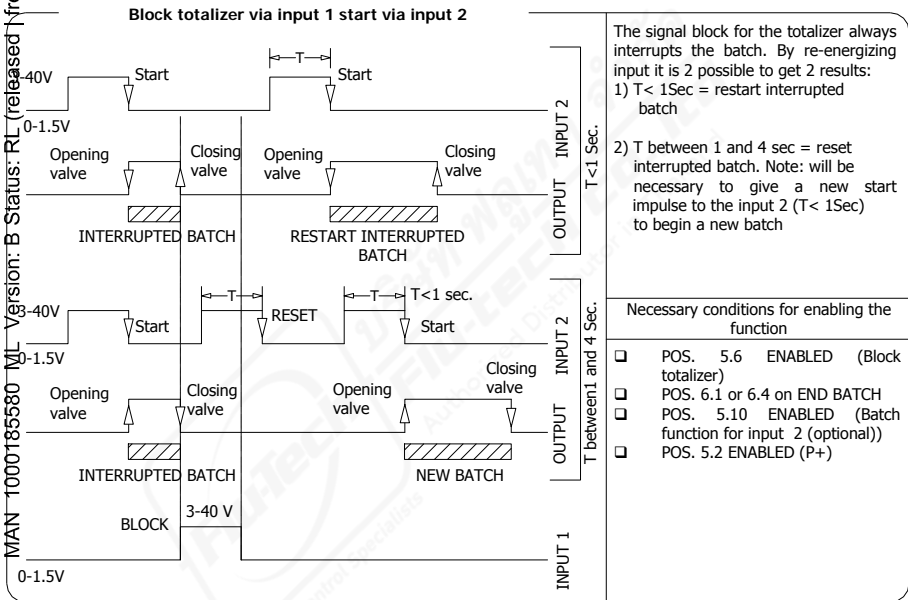
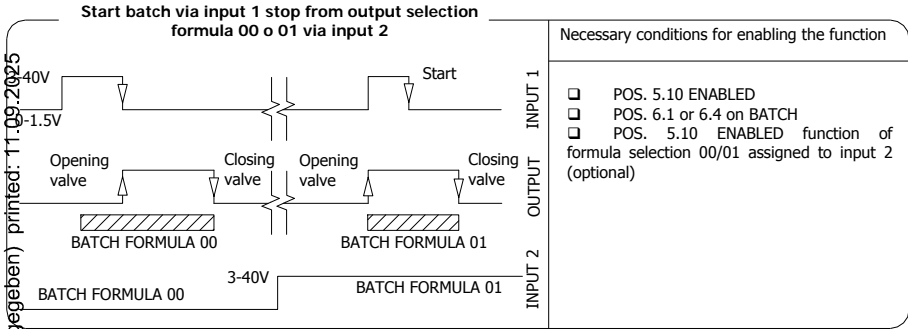

OUTPUT WIRINGS

Output on/off 1250Hz

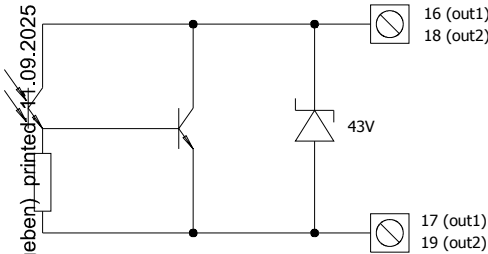

- Opto-insulated output with collector and emitter terminals floating and freely connectable
- Maximum switching voltage: 40V DC
- Maximum switching current: 100mA
- Maximum saturation voltage between collector and emitter at 100mA: 1.2V
- Maximum switching frequency (load on the collector or emitter, $R_L=470\Omega$, $V_{OUT}=24V$ DC): 1250Hz
- Maximum reverse current bearable on the input during and accidental polarity reversion (VEC): 100mA
- Insulation from other secondary circuits: 500V DC

OUTPUT 1/2 standard - OUTPUT 3/4 with modules

Output on/off 12500 Hz

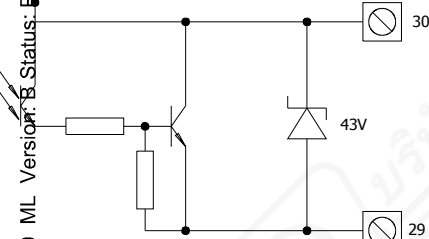

- Opto-insulated output with collector and emitter terminals floating and freely connectable. In order to get the maximum speed performances it is necessary to connect the emitter to the common terminal of the outputs (0V), while the load has to be on the collector. This output is internally connected to the power supply source 24V DC available on the terminal block.
- Maximum switching voltage: 40V DC
- Maximum switching current: 100mA
- Maximum saturation voltage between collector and emitter 100mA, load on the collector and internal power supply: 0.3V
- Maximum saturation voltage between collector and emitter 100mA, load on the emitter and internal power supply: 3V
- Maximum switching frequency, load on the collector and internal power supply: ($R_L=470\Omega$, $V_{OUT}=24V$ DC): 12500Hz
- Maximum switching frequency, load on the emitter or external power supply: ($R_L=470\Omega$, $V_{OUT}=24V$ DC): 2500Hz
- Insulation from the other secondary circuits (except 24V and 4-20mA outputs): 500V DC

Only with ME 201 module

4-20mA output

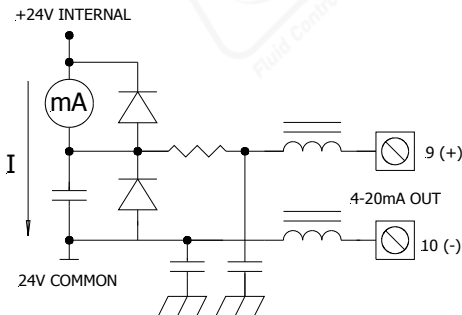

- Opto-insulated output
- Maximum load 1000 Ω
- Maximum voltage without load 27V DC
- Refresh frequency equal to the sample frequency of the connected sensor
- Protected against persistent over voltages up to 30V DC

The transmitter detects a loss of load on the 4 to 20mA output; to disable this function set the value "mA val. fault" to 0 (Pos. 4.6)

NOTE: shielded cables are recommended for inputs and outputs wiring.

TRANSMITTER ACCESS

FLAGS AND LED INTERPRETATION

MAN 1000185580 ML Version: B Status: RL (released | freigegeben) printed: 11.09.2025

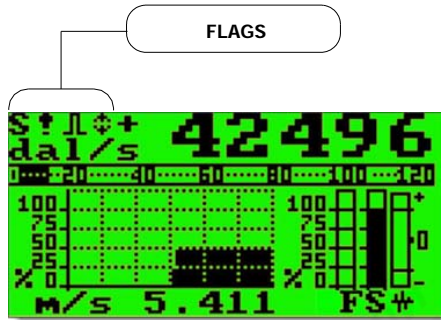

FLAGS INTERPRETATION	
FLAG	DESCRIPTION
↕	Alarm max/min activated - Interruption coils circuit
!	- Signal error - Empty pipe
C	Calibration running
S	Simulation
	Pulse output saturation (reduce TIME of the PULSE)

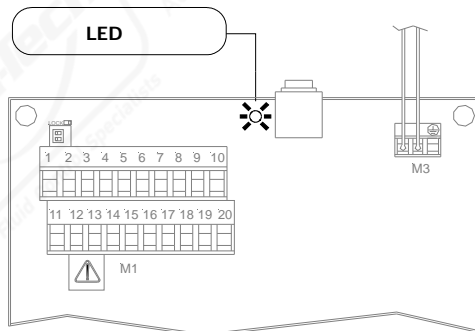

LED INTERPRETATION
PERMANENT LIGHT: initialization
FLASHING LIGHT (1 sec.): normal function
FLASHING LIGHT (<1 sec.): alarm active
The LED signals the real alarm status only if the display visualizes one of the visualization pages
ATTENTION: The LED is not visible in the panel-mounted version of the transmitter

KEYBOARD

MAN 1000185580 ML Version: B Status: RL (released | freigegeben) printed: 11.09.2025



SHORT PRESSING (< 1 SECOND):

Increases the numeric figure or the parameter selected by the cursor
Returns to the previous item on the menu
Batch start/stop (when enabled)

LONG PRESSING (> 1 SECOND):

Decreases the numeric figure or the parameter selected by the cursor.
Proceeds to the next item on the menu



SHORT PRESSING (< 1 SECOND):

Moves/positions the cursor rightward on the input field
Proceeds to the following item of the menu
Change the display of the process data

LONG PRESSING (> 1 SECOND):

Moves/positions the cursor leftward on the input field
Returns to the previous item on the menu

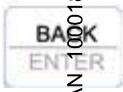

SHORT PRESSING (< 1 SECOND):

Enter/leave the selected function
Enables the main menu for the instrument configuration
Cancels the selected function under progress

LONG PRESSING (> 1 SECOND):

Leaves the current menu
Enables the totalizer reset request (when enabled)
Confirms the selected function

CONFIGURATION of a device without display

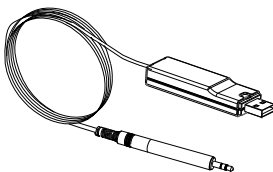

For the transmitters without display, the configuration is made through ISOCON (cable and software needed).

As the housing will be opened by the installer, the IP degree may be compromised, so follow the torques mentioned.

START-UP VISUALIZATION PAGES

The direct exposure of the transmitter to the solar rays, could damage the liquid crystal display. For the contrast set see pos. 8.3

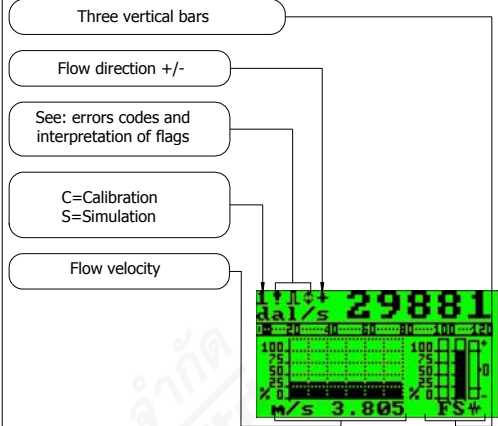
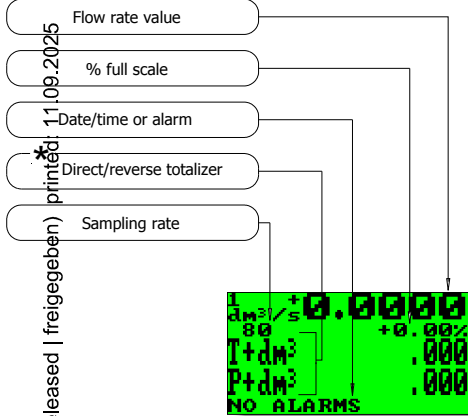

The three vertical bars represent the filters behaviors: first bar, "F", is the FAST filter, second bar, "S", is the "SLOW" filter and the third bar represents the variation of the new measure samples respect to the averaged value. It can give an indication about the total noise of the measure.

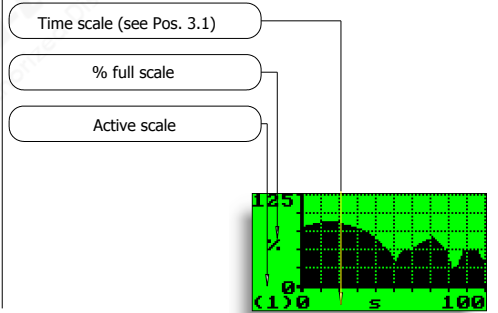
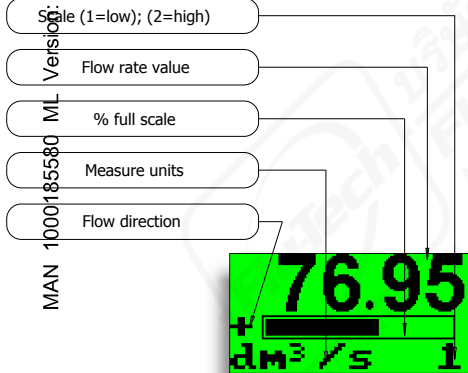

* The maximum digits shown by the totalizer is 999999999 independently from the number of selected decimals. Beyond this value the totalizers are reset.

TRANSMITTER VISUALIZATION PAGE WITH CURRENCY FUNCTION ENABLE

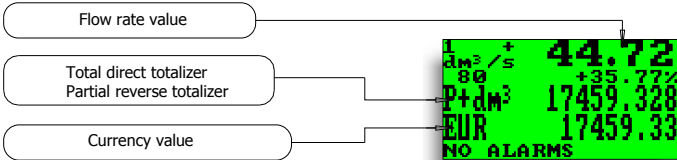

NOTE

The visualization of the pages can be changed in respect to some functions enabled or disabled (Pos. 8.4÷7÷8 and batch functions)



FLOW RATE VISUALIZATION

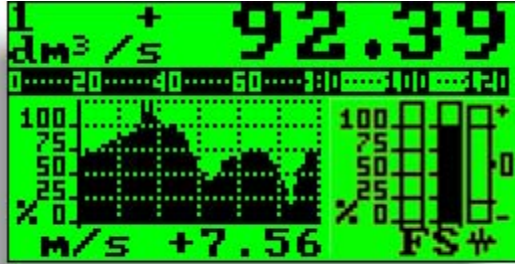

The transmitter can show a 5 digit character display for flow rate values; therefore the maximum flow rate value that can be represented on the display is **99999** (no matter the positioning of the decimal point). The minimum is **0.0025**.

The representable measure unit depends from sensor flow rate and diameter; the permitted units are those, set with the instrument full scale value, allow to be represented with a numerical field which the maximum value do not exceed **99999**.

Example for DN 300:

Full scale value: 3m/s

PERMITTED measure unit (example): l/s (216.00); m³/h (777.60); m³/s (0.2160)

NOT PERMITTED measure unit (example): l/h (777600)..

ACCESS CODES

Functions in the transmitter main menu are enabled by the access codes. The information in this manual is related to all the functions available with the L2 level. All the functions available through higher level are protected and reserved to the service.

Description of the L2 access code (menu "11 Internal data" pos. 11.1)

with code L2 = 000000 (only with this code) you can disable the L2 code request

* **with L2 customized** (freely chosen by the user) you can configure all the functions up to L2 security level, entering this code whenever you enter the Main menu.

*** ATTENTION:** take careful note of the customized code, since there is no way for the user to retrieve or reset it if lost.

Factory preset access codes

The transmitter is delivered with the default L2 (level 2) access code:

111111

BLOCK DIP-SWITCH

The block DIP-switch **disables** the access to the transmitter's functions.

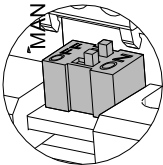

To activate this block move both switch to the ON position

NOTE: with block enabled it is possible to view all visualization pages pressing the key 

Factory pre-setting: DIP-SWITCH OFF

QUICK START MENU

The user has immediate access to the Quick Start menu when the transmitter is powered up by pressing the **Enter** key. If access to the quick start menu does not occur, then it has been disabled through the function 8.6

```

1.09.2025
- QUICK START
F1=dm³/s 4.0000
F2=dm³/s 4.0000
T.MU=dm³ 1.000
P1=dm³ 0.00002
P2=dm³ 1.00000
I1s1=ms 0050.00
I1s2=ms 0050.00
Damping= OFF
M=mm 00025
S mulation= OFF
C ntrast= 7
L nguage= EN
Main menu
    
```

See configuration functions section

Access to all functions

MAN 1000185580 ML Version: B Status: Release 1.09.2025

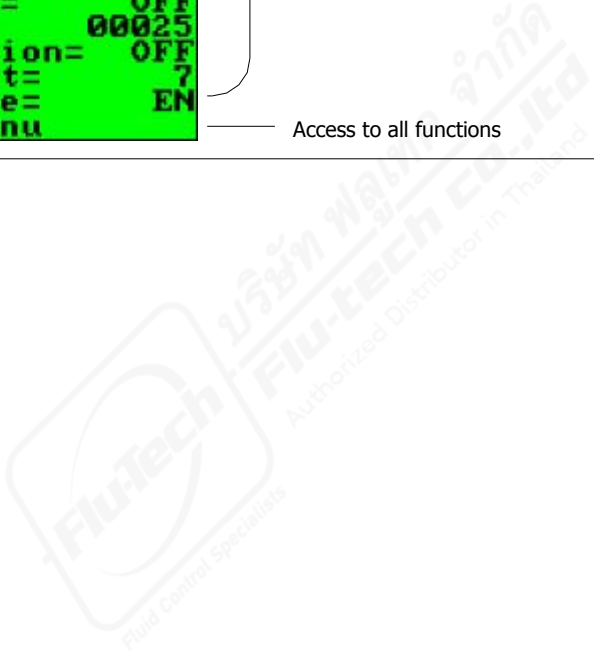

ACCESS TO THE CONFIGURATION MENU

The transmitter configuration menu can be accessed in two different ways:

- 1) by **ISOCON** interface
- 2) by **keyboard** of transmitter

ACCESS TO THE CONFIGURATION MENU BY ISOCON INTERFACE

MAN 1000185580 ML Version: B Status: RL (released | freigegeben) - printed: 11.09.2015

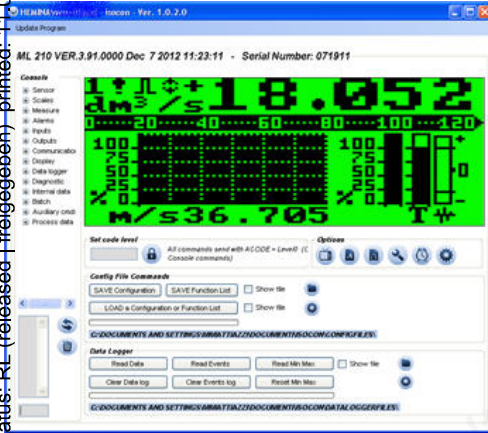

Isocon is a Windows® software that allows to set all the transmitter functions and personalize the menu (IF2 is required), see suitable manual for details

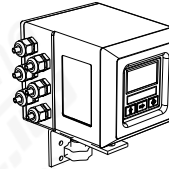

ACCESS TO THE CONFIGURATION MENU BY THE KEYBOARD

Functions can be accessed by the keyboard in two different ways:

- The **Quick start menu** makes direct access possible to a range of principal functions for setting the scale reading and display characteristics of the sensor. Quick start menu can be enabled by function 8.6 (menu display)



Factory pre-setting: QUICK START MENU=ON

- Through the **Main menu** it is possible to access functions with the access code level 2. These control the sensor's monitoring, data processing, input/output as well further display options.

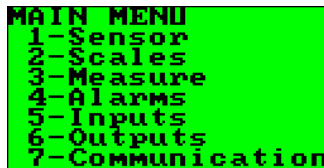

The following example shows how to change the Full scale by Quick Start menu; the second illustrates how to change the function by the Main menu.

MAN 1000185580 ML Version: B Status: RL (released | freigegeben) - printed: 11.09.2025

EXAMPLE: modifying the full scale value from 4dm³/s to 5dm³/s, from the "Quick start menu"

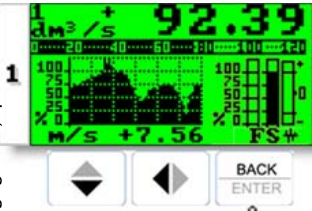

Enter in the "Quick start menu"



Access to the function "Fs1"



Repeatedly



Change the value

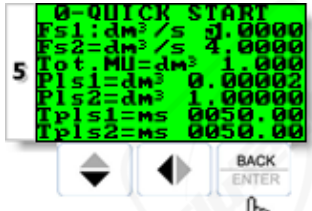

Confirm the new value

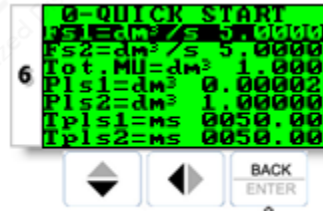

Long push



Main page

EXAMPLE: modifying the full scale value from 4dm³/s to 5dm³/s, from the "Main Menu" (quick start menu enabled)

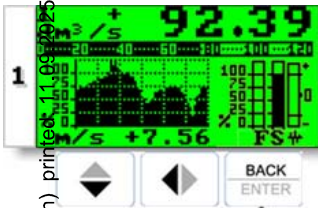

1 Enter in the "Quick start menu"



2 Move cursor down to Main menu



3 Access to the "Main Menu"



4 B Status: RL

X 6 TIMES



5 Confirm the keycode

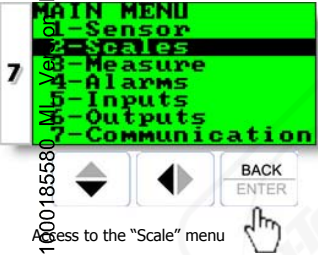
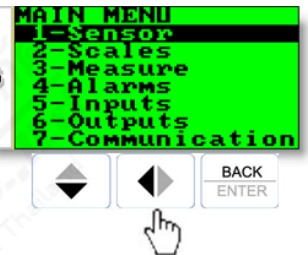

7 Access to the "Scale" menu

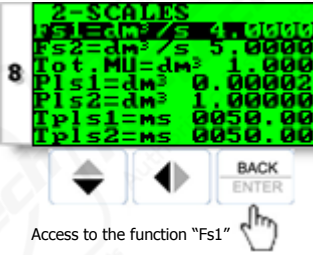

8 Access to the function "Fs1"

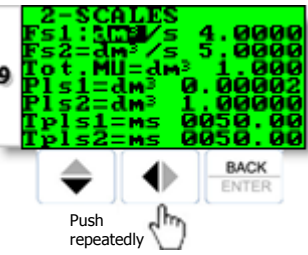

9 Push repeatedly

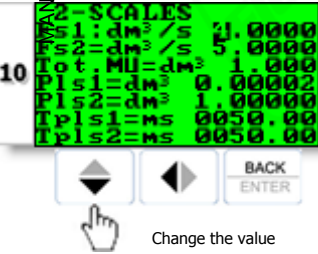

10 Change the value

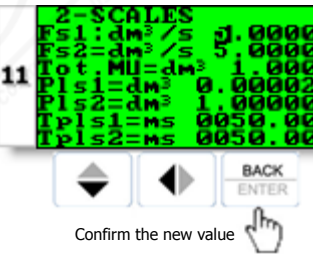

11 Confirm the new value

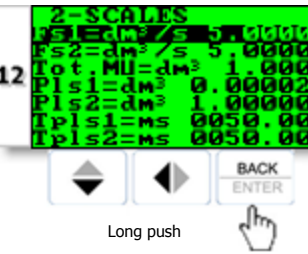

12 Long push

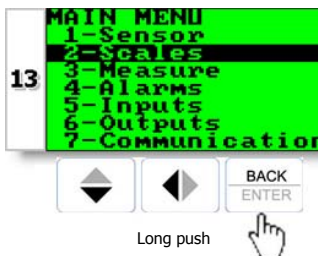

13 Long push



14 Main page

CONFIGURATION FUNCTIONS

(functions with access code < 3, those with symbol "*" see the next section)

Attention: The menu functions in grey colour are visualized on display only with other active functions or with optional modules

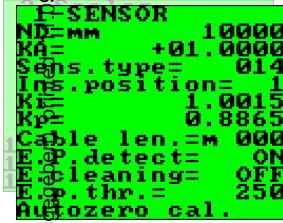

- 1.1 Insert ND (diameter size) of sensor (0-3000mm)
- 1.2 Sensor calibration data, visualized on sensor's label
- 1.3 Type of sensor: Enter the first two characters of the sensor serial number (see sensor label)
- 1.4 Position for insertion sensors: 0=1/8DN, 1=1/2DN, 2=7/8DN
- 1.5 Factory parameters automatically calculated (ONLY for insertion sensors)
- 1.6 Length of the cable connecting the sensor to the transmitter
- 1.7 Enables the empty pipe detection feature
- 1.8* Electrodes cleaning
- 1.9* Value of sensibility for empty pipe detection
- 1.10* Enables the automatic procedure of zero calibration

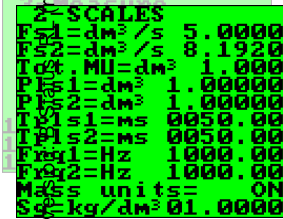

- 2.1* Full scale value set for range N.1
- 2.2* Full scale value set for range N.2
- 2.3* Unit of measure and number of decimal place
- 2.4* Pulse value on channel 1
- 2.5* Pulse value on channel 2
- 2.6* Duration of the pulse generated on channel 1
- 2.7* Duration of the pulse generated on channel 2
- 2.8 Full scale freq. for channel 1 (0.1Hz-1000.0Hz) (0.1Hz-10000Hz with opt. module)
- 2.9 Full scale freq. for channel 2 (0.1Hz-1000.0Hz) (0.1Hz-10000Hz with opt. module)
- 2.10 Enable/disable the selection of mass units on full scale set
- 2.11 Specific gravity set in kg/dm³



- 3.1* Measure filter
- 3.3 Low flow cut off threshold: 0-25% of full scale value
- 3.4 Enable every hour an internal cycle of calibration. Measurement stopped for 8-15 sec.
- 3.5* Automatic change of measurement range



- 4.1 Maximum value alarm set for direct flow rate
- 4.2 Maximum value alarm set for reverse flow rate
- 4.3 Minimum value alarm set for direct flow rate
- 4.4 Minimum value alarm set for reverse flow rate
- 4.5 Hysteresis threshold set for the minimum and maximum flow rate alarms
- 4.6* Current output value in case of failure
- 4.7* Frequency output value in case of failure
- 4.8* Batch safety timer

```

3-Measure
4-Alarms
5-Inputs
5-INPUTS
T+ reset= ON
P+ reset= ON
T- reset= OFF
P- reset= ON
Puls reset= OFF
Count lock= ON
Meas lock= OFF
Calibration= OFF
Range change=OFF
Batch= ON
Imp. 2= OFF
    
```

- 5.1* Total direct (positive) flow totalizers reset enable
- 5.2* Partial direct (positive) flow totalizers reset enable
- 5.3* Total reverse (negative) flow totalizers reset enable
- 5.4* Partial reverse (negative) flow totalizers reset enable
- 5.5 Reset totalizers of pulse from digital input (see page 14)
- 5.6 Totalizers counting lock command (see page 14)
- 5.7* Block measures command
- 5.8* Autozero calibration external command
- 5.9 Range change external command (see function 3.5)
- 5.10 Batch start/stop external command (see batch functions)
- 5.11*Functions assigned to input 2

```

4-Alarms
5-Inputs
6-Outputs
6-OUTPUTS
Out1= #1 IMP+
Out2= SIGN
Out3= OFF
Out4= #2 IMP+
Out1 MA1= 4:33
Out2 MA2= 4:33
    
```

- 6.1* Output 1 functions
- 6.2* Output 2 functions
- 6.3* Output 3 functions
- 6.4* Output 4 functions
- 6.5* Choice of the function and the range of current output n.1
- 6.6* Choice of the function and the range of current output n.2

```

6-Outputs
7-Communication
7- COMMUNICATION
IF2 pr.= DPP
RS232 pr.= DPP
RS485 bps= 19200
RS232 bps= 19200
Print= OFF
Print batch= OFF
Print data= OFF
Print events=OFF
Print delay=ms 20
Parity= NONE
Address= 000
Rev. addr.= 000
Remote u.conn.
    
```

- 7.1 Choice of the communication protocol for the IF2 device
- 7.2 Choice of the communication protocol for the RS232 port
- 7.3 Speed of the RS485 output (possible choices: 4800, 9600, 19200, 38400 bps)
- 7.4 Speed of the RS232 output (possible choices: 4800, 9600, 19200, 38400 bps)
- 7.5 Print function enable (optional)
- 7.6 Print of the performed batch
- 7.7 Print of the data process on regular intervals
- 7.8 Print of events
- 7.9 Instrument answer delay
- 7.10 RS485 parity
- 7.11 Address value of converter (range 0 - 255)
- 7.12 Address of a further converter connected like a terminal
- 7.13 Start remote connection to the terminal. Connection interrupted after 10sec. of inactivity

```

8-DISPLAY
Language= EN
D.rate=Hz 1
Contrast= 7
F. totaliz.= ON
Date/time= OFF
Quick start= OFF
Net total.= OFF
Currency= ON
Curr.decim.= 2
EUR/dm+= 1.00000
EUR/dm-= 1.00000
Reset video= OFF
I+ reset
P+ reset
T- reset
P- reset
    
```

- 8.1 Choice of the language: EN= English, IT=italian, FR= French, SP= Spanish, DE=German
- 8.2 Display updating frequency: 1-2-5-10 Hz
- 8.3* Display contrast
- 8.4 Partial totalizer visualization (with batch enable the function is always on)
- 8.5 Date and time visualization with data logger enable
- 8.6 Quick start menu visualization
- 8.7 Enable the page of net totalizer (difference between direct and reverse)
- 8.8 Visualizes the values of the partial totalizers in the unit of selected currency
- 8.9 Choice of the numbers of decimals for the visualization currency value: From 0 to 3
- 8.10* Value of conversion/currency for direct totalizer
- 8.11* Value of conversion/currency for reverse totalizer
- 8.12 Reset the processor of the display (useful in case of particular badly operations of the display)
- 8.13* Total direct (positive) flow totalizer reset
- 8.14* Partial direct (positive) flow totalizer reset
- 8.15* Total reverse (negative) flow totalizer reset
- 8.16* Partial reverse (negative) flow totalizer reset

```

9-Data logger
10-Diagnostic
11-Internal data
12-Batch
    
```

<pre> 9-DATA LOGGER 19/02/05/10 15:03 Interval= ON Interval-h 24 Display data Display events Disp.min/max Clear data Clear events Reset min/max </pre>	<ul style="list-style-type: none"> 9.1* Date and time set 9.2 Automatic data logger enable 9.3 Interval time for the data logging function: 1, 2, 3, 6, 8, 12, 24, 48 hours 9.4 Displaying of the data stored in the data logger 9.5 Displaying of the last 64 alarms stored in the data logger 9.6 Visualization function of minimum and maximum peak of flow rate 9.7 Logged data cancel function 9.8 Reset all alarm events 9.9 Reset all minimum and maximum peak of flow rate stored
--	--

<pre> MAIN MENU 10-DIAGNOSTIC Calibration Self test Simulation= OFF Firmware rev. </pre>	<ul style="list-style-type: none"> 10.1* Calibration of the transmitter 10.2* Autotest transmitter 10.3* Flow rate simulation enabling 10.4 Firmware revision/version
--	---

<pre> MAIN MENU 11-INTERNAL DATA L2 keycode=00000 Load fact.pres. Load user pres. Save user pres. Ignore cal.err= OFF Ks coefficient +1.0000 </pre>	<ul style="list-style-type: none"> 11.1 Level 2 access code enter 11.2 Load factory data pre-set 11.3 Load user data saved 11.4 Save user data 11.5 Ignore the calibration error during the switch on test 11.6 Ks coefficient (only for service purposes)
---	--

Menu 12: Menu visualized only with batch active
(see batch function in configuration section)

<pre> 12-BATCH N.samples= 000 Diff.thr=% 010 U.com=dm³ 00.000 U.pre=dm³ 00.000 Auto batch= OFF BM auto sel= OFF Cons.mode= OFF </pre>	<ul style="list-style-type: none"> 12.1* Number of batch cycles to define the value of compensation. Value 0=OFF 12.2* % limit of compensation threshold 12.3* Compensation value 12.4* Prebatch value 12.5* Auto-batch 12.6* Automatic selection of batch formula 12.7* Static signal starting batch
---	--

FUNCTIONS DESCRIPTION

(description of the functions with access code < 3)

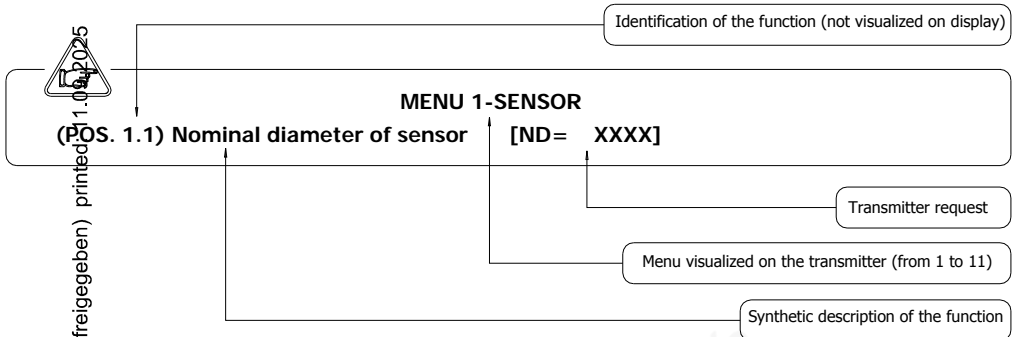

The following pages give a description of the most important functions and how they can be changed or enabled/disabled by the user

MENU 1 - SENSOR

(POS. 1.8) Electrodes cleaning

[El. cleaning=MIN]

Selectable options: OFF, minimum, average and maximum. It is not recommended to use this function (let OFF) when the liquid has a conductivity less than 100µS/cm.

(POS. 1.9) Empty pipe threshold

[E.P. thr.=XXX]

This value represents the threshold at which the measurement value is set to zero in case of empty pipe condition; the span function is 20-250. Since the sensibility of empty pipe detection could be changed by the liquid conductivity, ground connections, type of lining, in case of needed it is possible to adjust manually the preset threshold. It is recommended to check periodically its proper functioning. Value increasing means sensibility decreasing.

(POS. 1.10) Autozero calibration

[Autozero cal.]

This function activates the zero calibration automatic system. To perform this operation, it is necessary for the sensor to be full of liquid, and the liquid be perfectly still. Even minimal movement of the liquid may affect the result, and consequently, the accuracy of the system. Once you are sure the above conditions have been fulfilled (and the percentage flow rate value is stable) press long the key **↵** and automatically activates the zeroing procedure, after which it is necessary to check that the percentage value showed goes to zero, repeat the operation otherwise. When the value is stable at zero, then press the key **Enter**.

MENU 2 - SCALES

(POS. 2.1-2) Full scale n° 1-2

[Fs1-2=dm³/S X.XXXX]

The full scale is used to indicate to the maximum meter's flow rate; a volume per time is required. The full scale should be chosen carefully as it's parameters are used for several other parameters (Pls1-2, and 3 Measure). There are four fields to fill in order to set this parameter, from left to right: 1) volume unit of measure, 2) type of unit, 3) time unit of measure and 4) numeric value. The selection is made by positioning the cursor on the field to modify. To change the type of unit of measure (metric, British or American, mass or volume) the cursor has to be positioned on the symbol " / " (field N. 2). When the nominal diameter is set to zero it is possible to modify only the numeric field, since the unit of measure stays at m/sec. The following tables show the units of measure available and the conversion factor by comparison with 1dm³ and 1kg. The transmitter accepts any kind of combination of units of measure satisfying both the following conditions:

- Numeric field value ≤ 99999
- 1/25 fs_{max} ≤ numeric field value ≤ fs_{max}

where $f_{s,max}$ is the maximum full scale value corresponding to the sensor, equal to a 10m/s liquid speed. The measure units are shown as appear on the display. The British and American units are diversified by using capital and small characters.

cm³	Cubic centimetre
ml	Millilitre
l	Liter
dm³	Cubic decimeter
dal	Decalitre
hl	Hectolitre
m³	Cubic metre

in³	Cubic inch
Gal	American gallon
GAL	British gallon
ft³	Cubic foot
Bbl	Standard barrel
BBL	Oil barrel
yd³	Cubic yard
kgl	KAmerican gallon
KGL	KBritish gallon

G	Gram
Kg	Kilogram
T	Ton

Oz	Ounce
Lb	Pound
Ton	short tons

When a measure mass unit is set, the specific gravity function is automatically enabled by the system. Please, note that the mass measure is heavily affected by the temperature. With certain liquids this may cause significant measurement errors. The following measure of time units can be selected: **s** = second, **m** = minute, **h** = hour, **d** = day.

(POS. 2.3) Measure unit and decimal totalizers number [Tot.MU:dm³X.XXX]

Setting the measure unit and decimals number for visualized totalizers or the volumes to batch. Setting the measure unit and decimals places number displayed for the volumes. To set the measure unit position the cursor on field of the measure unit. To set the unit type, position the cursor on the blank space between the measure unit and the numeric value; the number decimal places can be selected by placing the cursor on numeric field and choosing one of the possible combinations: 1000-01.00-001.0-00001.

(POS. 2.4-5) Pulse value channel 1-2 and unit of measure of tot. [Pls1-2=dm³X.XXXXX]

This function allows the user to set a signal (a pulse) to be given from the transmitter when a defined amount of liquid has passed through the sensor. To set the parameter, complete the three fields, from left to right: 1) measure unit, 2) unit type and 3) numeric value. The selection is performed by positioning the cursor in the field to be modified. To change the unit type (metric, British or American, mass or volume) position the cursor on the blank space between the measure unit and the numeric value. When the nominal diameter is set to zero it is possible to modify only the numeric field since the measure unit stays at meters (m) or feet (ft). Only those units described above are available to be selected.

(POS. 2.6-7) Pulse duration channel 1-2 [Tpls1-2=msXXXX.XX]

With the liquid volume to generate the pulse value (pos 2.4-5) set by the user. The user must set the corresponding duration of the pulse to be outputted. This value is expressed in milliseconds and has to be between 0.4 and 9999.99. When the high frequency output is present, then the minimum value can type of device is connected to the transmitter, the user must verify that the set pulse duration is compatible with the external device processing such pulses. If, for example, an electro-mechanical pulse counter is connected, one of be set to a minimum of 0.04 milliseconds. ATTENTION: since the transmitter can not detect which two problems may occur; firstly, if the pulse is too long the coils may burn out, secondly, if the pulse is too short, the counter may not be able to function, with the possibility of causing damage of the output.

MENU 3 - MEASURE

(POS. 3.1) Damping

[Damping=OFF/SMART X / (time)]

This section of the manual is extremely important. The correct filter settings ensures a proper response of the instrument to the measured flow rate. The available dampening filter values range between no damping (damping=OFF) and maximum damping based of 1000 seconds (Damping=1000).

The three diagrams below demonstrate the instrument behavior with different dampening settings with flow rate changes in the range of 1-100%.

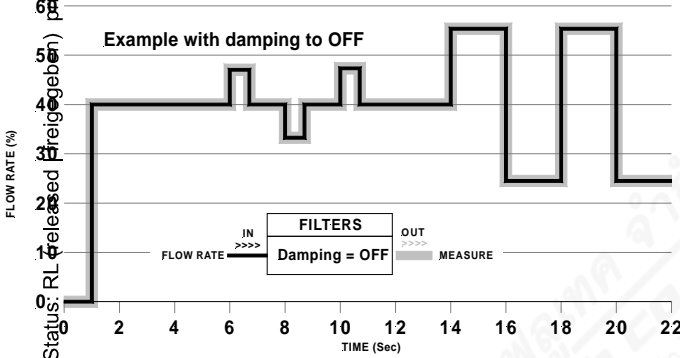

Damping function(OFF). the meter follows the trend of fast changes in flow

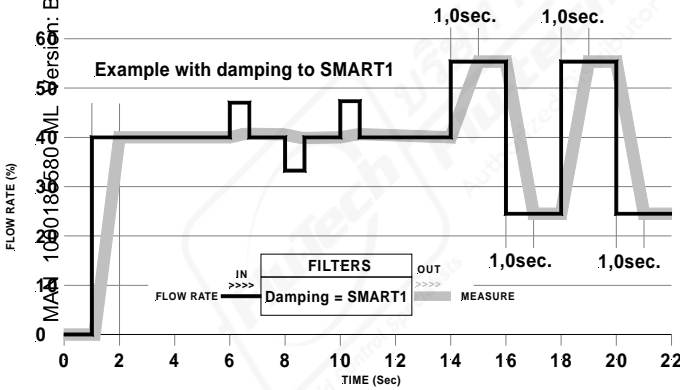

Damping (Smart 1,2,4): these settings effect a predefined filter dampening of the noise and sudden change in flow rate on the rise.

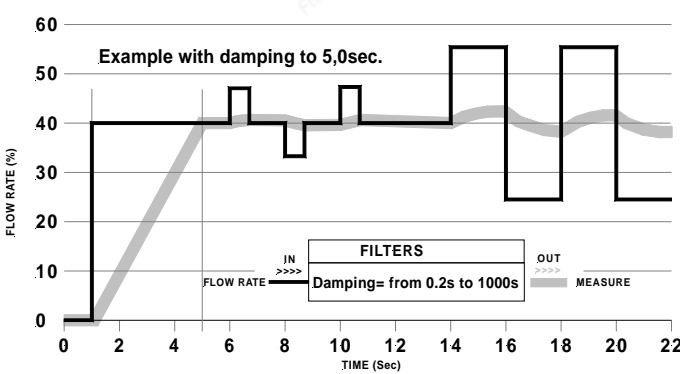

Damping mode based on time (from 0.2s to 1000s) The measure is averaged over a number of samples determined by the value assigned to the dampening function. When the damping parameter is expressed in seconds, the filter works dampening the measurement noise and sudden change of flow rate. Increasing the parameter of damping increases the stability of the measurement.

(POS. 3.5) Automatic scale change enable

[Autorange=ON/OFF]

Enables the automatic change of scale. The meter may have two different working ranges in order to suit to the variable process conditions. In order to get the best results out of this function it is important range N.2 (Fs2) if enabled is bigger than N.1 (Fs1). When the flow rate increases and reaches the 100% of the full scale 1, then the meter automatically switches to scale 2. When the flow rate decreases again reaching a value on scale 2 equal to the 90% of full scale N.1, then the active scale is 1 again. Allowed values for this parameter: ON/OFF. **Note:** the autorange does not allow using the manual change of range (pos. 5.8)

MENU 4 - ALARMS

(POS. 4.6) Current output value in case of failure

[mA V.fault =% XXX]

The output current signal can be specified by the user in case of failure of either, empty pipe, coils interrupted, or ADC error. The signal current is set as a percentage (0 to 120%) of the 0/4-20mA current. 120% corresponds to 24mA and does not depend on the selected range (0-20/4-20mA). The NAMUR NE43 recommendation asks for a alarms signalling value for the current output lower than 3.6mA (<18%) or bigger than 21mA (>105%). It would then be preferable to set the value of this function at the 10%, so that the current value in case of the a.m. cases would be 2 mA, allowing the following diagnostics:

- current < 2mA - 5%: line interrupted, power supply failure or faulty transmitter;
- 2mA - 5% ≤ current ≤ 2mA + 5%: hardware alarm;
- 4mA ≤ current ≤ 20mA: normal working range;
- 0mA < current ≤ 22mA: out of range, measure above 100% f.s.

Note: To set this parameter to zero disables the alarm

(POS. 4.7) Frequency output value in case of failure

[Hz V.fault=%XXX]

To set the frequency value assigned to the on/off output in one or more of the following failure cases:

- Empty pipe; Coils interrupted; ADC error

Allowable range is from 0 to 125% of the frequency full scale value.

Although there are no specific rules regulating cases such as these, it would be convenient to use the following information as follows:

- 0% Hz ≤ frequency ≤ 100% f.s.: normal working range;
- 100% f.s. < frequency ≤ 110% f.s.: overflow, measure above the 100% of the f.s.;
- 115% f.s. ≤ frequency ≤ 125% f.s.: hardware alarm condition.

(POS. 4.8) Batch safety timer

[Timeout =s XX.X]

With this function is possible to set a maximum time for the batch ; over this time will be generate an alarm.

This function is useful when you need control one or both of the following conditions:

- batch valve open and flow rate is zero
- batch valve closed and flow rate different to zero

When this alarm is activate, the batch operation and power supply to the value is halted. The allowed values of function are from 0 (disable) to 25.5 seconds and is active only if one or more of the batch functions are enabled.

MENU 5 - INPUTS

(POS. 5.1-4) Reset totalizer enable [T/P +/--RESET=ON/OFF]

When one of this function is enabled, the related totalizer may be reset through the on/off input.

(POS. 5.7) "Block measures" command block measures enable [Meas. lock=ON/OFF]

When this function is active (ON), applying a voltage on the on input terminals, the measurement is stopped, the meter will display zero flow.

(POS. 5.8) "Autozero" calibration external command enable [Calibration=ON/OFF]

When this function is active, applying a voltage on the on/off input terminals the meter performs a autozero calibration cycle. ATTENTION: If the voltage pulse is less than 1 sec., the meter performs a calibration cycle to for compensate possible thermal drifts. If the voltage pulse is more than 1 sec, the meter performs a zero calibration measure. This function enables/disables the automatic zero calibration of the system. To perform the calibration it is absolutely necessary for the sensor to be full of liquid and that the liquid is perfectly staying still. Even very small movement of the liquid may affect the result of the calibration, and, consequently, the accuracy of the system.

(POS. 5.11) Functions assigned to input 2 [Inp.2=XXXXXX]

Allows to choose the function associated to input 2. The functions are listed in the table below.

FUNCTIONS FOR INPUT 2

- OFF: DISABLE
- T+ RESET: RESET TOTAL DIRECT TOTALIZER FOR DIRECT FLOW RATE (+)
- P+ RESET: RESET PARTIAL DIRECT TOTALIZER FOR DIRECT FLOW RATE (+)
- T- RESET: RESET TOTAL REVERSE TOTALIZER FOR REVERSE FLOW RATE (-)
- P- RESET: RESET PARTIAL REVERSE TOTALIZER FOR REVERSE FLOW RATE (-)
- BATCH: START/STOP BATCH
- BM SELECTION: STATIC SELECTION OF FORMULA

MENU 6 - OUTPUTS

(POS. 6.1-4) Function corresponding to on/off output 1-2-3-4 [OUT1=XXXXXX]

Choice of the function corresponding to digital outputs. The functions are listed in the table below.

The output 3-4 are optional and the output 4 is the only output, which can reach a 12.5 kHz frequency.

FUNCTIONS ASSOCIATED TO THE OUTPUTS 1, 2, 3, 4

- OFF: DISABLED
- #1 IMP+: PULSE ON CHANNEL 1 FOR POSITIVE FLOW RATE
- #1 IMP-: PULSE ON CHANNEL 1 FOR NEGATIVE FLOW RATE
- #1 IMP: PULSE ON CHANNEL 1 FOR POSITIVE AND NEGATIVE FLOW RATE
- #2 IMP+: PULSE ON CHANNEL 2 FOR POSITIVE FLOW RATE
- #2 IMP-: PULSE ON CHANNEL 2 FOR NEGATIVE FLOW RATE
- #2 IMP: PULSE ON CHANNEL 2 FOR POSITIVE AND NEGATIVE FLOW RATE
- #1 FREQ+: FREQUENCY CHANNEL 1 FOR POSITIVE FLOW RATE
- #1 FREQ-: FREQUENCY CHANNEL 1 FOR NEGATIVE FLOW RATE
- #1 FREQ: FREQUENCY CHANNEL 1 FOR POSITIVE AND NEGATIVE FLOW RATE
- #2 FREQ+: FREQUENCY CHANNEL 2 FOR POSITIVE FLOW RATE
- #2 FREQ-: FREQUENCY CHANNEL 2 FOR NEGATIVE FLOW RATE
- #2 FREQ: FREQUENCY CHANNEL 2 FOR POSITIVE AND NEGATIVE FLOW RATE
- SIGN: FLOW DIRECTION OUTPUT (ENERGIZED = -)
- RANGE: RANGE INDICATION OUTPUT (ENERGIZED = SCALE 2)
- MAX AL.+ : MAX DIRECT FLOW RATE OUTPUT(ENERGIZED = AL. OFF)
- MAX AL.-: MAX REVERSE FLOW RATE OUTPUT(ENERGIZED = AL. OFF)
- MAX AL.: MAX DIRECT/REVERSE FLOW RATE OUTPUT(ENERGIZED = AL. OFF)
- MIN AL.+ : MIN DIRECT FLOW RATE OUTPUT(ENERGIZED = AL. OFF)
- MIN AL.-: MIN REVERSE FLOW RATE OUTPUT(ENERGIZED = AL. OFF)
- MIN AL.: MIN DIRECT/REVERSE FLOW RATE OUTPUT(ENERGIZED = AL. OFF)
- MAX+MIN: MAX AND MIN FLOW RATE ALARM OUTPUT (ENERGIZED = AL. OFF)
- P. EMPTY: EMPTY PIPE ALARM OUTPUT (ENERGIZED = FULL PIPE)
- OVERFLOW: OUT OF RANGE ALARM OUTPUT (ENERGIZED = FLOW RATE OK)
- HARDW AL.: CUMULATIVE ALARM OUTPUT interrupt coils, empty pipe, measure error (ENERGIZED = NO ALARMS)
- BATCH AL.: BATCH ALARM
- EXT. COMM.: ONLY AVAILABLE WITH DATA LOGGER MODULE
- BATCH SYN.: AT THE AND OF BATCH THE OUTPUT CHANGE STATUS
- END BATCH.: END BATCH OUTPUT (ENERGIZED =BATCH IN PROGRESS)
- PREBATCH.: PREBATCH OUTPUT (ENERGIZED = PREBATCH IN PROGRESS)

MAN 1000185500 | Version: B Status: RL (released) | Page 10 of 10

(POS. 6.5-6) Function and the range of current output n.1-2 [Out mA1-2=X÷XX+]

The function associated to the signal current on output N.1-2. The current output N.1 is optional and it is mounted on the main board. There are three fields to modify for this function:

- Scale zero: 4 or 0mA;
- Full scale: 20 or 22mA
- Field: + = positive, - = negative, blank = both, -0+ = central zero scale

The values corresponding to the scale points are shown in the following chart:

POSSIBLE FIELD	CURRENT VALUES IN mA ASSOCIATE TO THE % VALUE OF FULL SCALE				
	REVERSE FLOW VALUE		ZERO	DIRECT FLOW VALUE	
	≤ -110%	-100%	0%	+100%	≥+110%
OutmA = 0 + 20 +	0	0	0	20	20
OutmA = 0 + 22 +	0	0	0	20	22
OutmA = 4 + 20 +	4	4	4	20	20
* OutmA = 4 + 22 +	4	4	4	20	22
OutmA = 0 + 20 -	20	20	0	0	0
OutmA = 0 + 22 -	22	20	0	0	0
OutmA = 4 + 20 -	20	20	4	4	4
OutmA = 4 + 22 -	22	20	4	4	4
OutmA = 0 + 20	20	20	0	20	20
OutmA = 4 + 22	22	20	0	20	22
OutmA = 4 + 20	20	20	4	20	20
OutmA = 4 + 22	22	20	4	20	22
OutmA = 0 + 20 -0+	0	0	10	20	20
OutmA = 0 + 22 -0+	0	1	11	21	22
** OutmA = 4 + 20 -0+	4	4	12	20	20
OutmA = 4 + 22 -0+	4	4.8	12.8	20.8	22

In hardware alarm conditions "HARDW AL." (interrupted coils, empty pipe, measure error) the current value is configured by the function "mA v.fault" (pos. 4.6) and it is expressed as percentage of a fixed current range, where: 0% = 0mA and 110% = 22mA.

Example 1: out 4-22 +

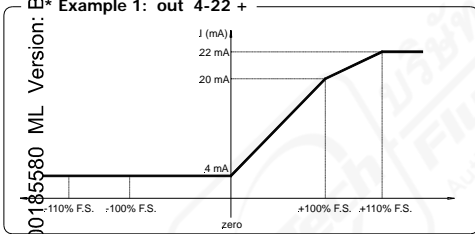

** Example 2: out 4-20 -0+

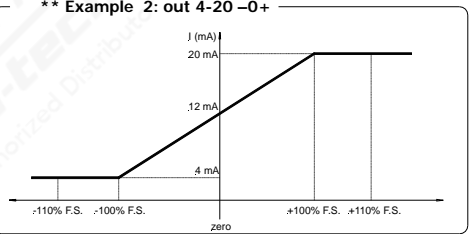

MENU 8 - DISPLAY

(POS. 8.3) Display contrast set

[Contrast=X]

Visual display contrast set. The contrast can change according to the room temperature. The set values are from 0 to 15. The entered value has effect only when leaving the function itself. **WARNING** >10 is a dark screen and obscures writing on the display

Contrast also can be set from visualization pages pushing the key  for 8 seconds or more. In this way the contrast set that will be visualized at release of the key.

(POS. 8.10-11) Conversion factor for flow rate totalizers

[EUR/dm³ +/- =X]

Setting of the conversion/currency value for direct (and reverse) flow totalizers. There are three setting fields for this parameter, from left to right: 1) monetary symbol, 2) default/personalized monetary symbol, 3) conversion coefficient. To modify, set the cursor over the required field. Setting the monetary symbol can be achieved in two ways:

1. Choosing one of the 7 predetermined monetary symbols (standard ISO 4217-REV81): EUR=Euro; USD=USA dollar; CAD=Canadian dollar; AUD=Australian dollar; GBP=English pound; CHF=Swissfranc; JPY=Japanese yen.
2. Entering a three character (numbers or letters) personalized currency. To change the characters, the cursor must be set on the symbol "/" (second field)

MAN 1000185580 ML Version: B Stäubli ML (released | freigegeben) printed: 11.09.2025

(POS. 8.13-16) Total/partial totalizers reset

[T/P/-/+ reset]

Activates the reset of total and partial flow totalizer. These functions are activated by pressing the key **Enter** during the visualization of the function itself. When "EXECUTE?" is required, press long **Enter** to proceed. Press any other key to cancel the operation.

MENU 9 - DATA LOGGER

(POS. 9.1) Date and time set

[☉ = dd/mm/yy hh:mm]

Date and time set. If the real time clock optional module is present, then the time setting is kept when the transmitter power supply is off, otherwise the clock is frozen until the power supply to the transmitter is resumed. For example, if the power supply has been off for one hour, when switched on the transmitter will be one hour behind actual time. The calendar is valid till year 2091.

MENU 10 - DIAGNOSTIC

(POS. 10.1) Meter calibration

[Calibration]

Enables the calibration of the meter. The activation of this function happens pressing the key **Enter** during the visualization of the function. The following message will be visualised on the screen: "EXECUTE?" press long the key **Enter** to proceed. Press any other key to cancel the operation.

(POS. 10.2) Autotest function

[Self test]

Meter autotest function. This function stops the normal functions of the meter and performs a complete test cycle on the measure input circuits and on the excitation generator. To activate this function, after select it, push key **Enter**, at the question: "EXECUTE?" push long the same key for start autotest, or any other key for delete operation. The result of the test is shown on the display. At the end of operation the transmitter will revert to one of the initial visualization pages. This function is automatically performed when switching on the device.

(POS. 10.3) Flow rate simulation

[Simulation=ON/OFF]

Flow rate simulation enabling. With this function it is possible to generate an internal signal that simulates the flow rate, allowing the outputs and all the connected instruments test. After enabling it, a **S** appears in the top left of the screen and the flow rate simulation can be:

- Set:** by pushing the key **Enter** from one of visualization pages, to set the required % flow rate (Fl.rate=%) and the same key to confirm the value;
- Finished:** by pushing the key **Enter** from visualization pages and then by long pushing the same Key.

The batch functions allow the user to set the transmitter to measure a defined volume of fluid and control outputs. An example is opening and closing a valve after a predefined volume has passed the sensor. The user sets the volume and the control parameters by the transmitter through the following functions (Main menu function group 12 'Batch')

MENU 12 - BATCH

Menu visualized only with batch active (output on batch and/or pos. 5.9 enable or 5.10 on batch)

(POS. 12.1) Number of batch samples [N.samples=XXX]

Number of batch cycles to be completed to define the value of compensation. This function allows the transmitter to automatically determine the average value for the automatic compensation of the system delay (pos. 12.3). Set the value to ZERO to manually introduce the compensation value.

(POS. 12.2) % limit of compensation [Diff.thr=%XXX]

This value defines the percentage of maximum difference between the compensation value set (see pos. 12.3) and the average compensation value defined with the function 12.1. Over this threshold the new compensation value will be automatically set (if number of batch samples is different from zero)

(POS. 12.3) Compensation value [V.com.=XX.XXX]

This value is expressed in the units of measure selected. The compensation value is the difference between the batch value set and the actual system delays due to closing valves, stop pumps, stop motors, etc. To set the compensation value manually, preset to ZERO the number of batch samples (pos. 12.1)

(POS. 12.4) Prebatch value [V.pre=XX.XXX]

This sets the volume of liquid at which the Pre-batch is enabled. When the pre-batch volume (V.pre) is reached the output (if enabled) is deactivated. This value is constant for all quantities to be batched and must be set in current volume unit of measure. The pre-batch function is useful when you need fast and accurate dosages.

(POS. 12.5) Enable/disable auto-batch function [Auto batch=ON/OFF]

By applying a voltage to the on/off input terminals for more than 5 second opens the value controlled by the transmitter. When the required flow volume has passed, the input voltage is removed, closing the valve. The transmitter memorizes the volume supplied in the current batch memory. (see "Batch Functions"). The volume set in this procedure will be the batch volume supplied in every following activation of the batch function. In order to modify this value, repeat the operations described above. This procedure set the safety timer at a value 1.25 times greater than the time used to reach the batched quantity; after that the counter will be reset.

(POS. 12.6) Automatic selection of batch formula [BM auto sel=ON/OFF]

The function allows the automatic selection of the first 4 formulas depending on the duration of the pulse of the batch start (see page 15 "Operation stage on input 1 or 2"). This function is active only if the function Cons. mode (pos. 12.7) has not enabled (OFF). With the 'Static consent of batch', the automatic compensation of the batch volume is excluded (additionally the value of the parameter "N.samples" (pos. 12.1) will be automatically be set to zero). However the manual compensation is possible by inserting an appropriate value on the parameter "V.com" (pos. 12.3)

(POS. 12.7) Static consent of batch [Cons. mode=ON/OFF]

This function enables the start and stop of the batch dosing using a static signal, instead of an impulse, applied to the input (see page 13 "Digital inputs"), this signal has to be constantly applied throughout the batch. This function automatically disables the functions 'BM auto sel' (pos. 12.6) and 'Auto batch' (pos. 12.5).

BATCH FUNCTION CONFIGURATION

ENABLE BATCH

Select one of the following functions to enable and configure the batch on the transmitter:

- POS. 5.9-5.10: START/STOP batch from input
- POS. 6.1-6.2: assign one of the functions outputs one and/or two

Some examples of operation of such functions are visualized from page 14.

VISUALIZATION PAGE WITH BATCH FUNCTION ENABLED

released | freigegeben) printed: 11.09.2025

Configuring formula n°

Product Name

Batch in progress

Visualizations:
 1) batch off: n° batch effected
 2) batch on: decrease safety timer
 3) configuration: safety timer indefinite if timer=0 timer disabled

Configuration of batch quantity

Visualization batched product

Vertical bars behavior

- First bar: volume that is distributing, 100% represents the volume to be delivered, identified by the "drop" symbol
- Second bar: dosing timer, 100% represents the security maximum time set for the batch, "T" symbol
- Third bar: remains deviation measure, as a normal flow measure

From the visualization pages

MAN 1000185580 ML

Long push

Input key code

Choose the formula number for associate quantity batch (between 00 and 15)

Input quantity product for each batch

Long push

Enter product name for batch (max 8 characters)

Enter maximum time for batch

If timer = 0, safety timer disabled max time set = 6000 sec.

Note: If one of the outputs has a batch alarm assigned. Upon the completion of the batch or an interruption, an alarm is activated.

CONFIGURATION of A BATCH

For each formula you can associate:

- Product quantity
- Product name
- Maximum time for batch (safety time for each formula)

After activating the batch function from visualization page, proceed as illustrated and described in the aside example.

START STOP BATCH



START: it is possible to activate the start of batch in two different ways:



1. **From remote input:** assigning the functions of start/stop batch to the input 1 (pos. 5.9) or input 2 (pos. 5.10) and using the inputs like visualized from page 14.
2. **From keyboard:** short pressing of the key .
N.B.: The start of batch from keyboard is always initiated on the release of the key. The function is not available with the batch consent (pos. 12.7) function enabled.

STOP: A batch may stop (be stopped) due to three events:

1. **Keyboard or remote input** (manual stop): short pressing of the key .
2. **End of batch:** In this case the batch will be stopped once the batch quantity has been achieved and a signal given
3. **Maximum time of batch:** If a maximum batch time has been set, and is exceeded, the batch in progress is stopped independently from the batched quantity.

Notes:

 during the batch the symbol of the active batch  and the name of the formula are visualized on display.

 When the batch outputs are enabled, pushing the key  for more than 5 seconds will energize the outputs until the key is released. On the display, In place of the CT and ST totalizers the following message will appear:

!! VALVE !!
!! OPENED !!

IMPORTANT NOTES

The start of the batch disables any function listed in the table below:

MAN 100185580 ML * using Input 1 * value set to zero		POS 12.5	POS 12.6	POS 5.6	POS 12.1	POS 5.9	POS 3.5-5.8	POS 3.6	POS 5.7
		AUTO BATCH	BM AUTO SEL	BLOCK TOTALIZER	N. SAMPLES	INPUT 1 ON START/STOP BATCH	AUTO RANGE CHANGE OR FROM INPUT	ENERGY SAVING	CALIBRATION
POS 12.5	AUTO BATCH			*DISABLE					
POS 12.6	BM AUTO SEL				** DISABLE				
POS 12.7	CONS. MODE	DISABLE	DISABLE	* DISABLE					
POS 5.9	INPUT 1 ON START/STOP BATCH						DISABLE	DISABLE	DISABLE
POS 5.10	INPUT 2 ON START/STOP BATCH					DISABLE	DISABLE	DISABLE	DISABLE
POS 5.10	INPUT 2 on BM SELECT		DISABLE		** DISABLE				
POS 6.1-4	OUTPUT ON END BATCH							DISABLE	

To optimize the performances of the meter used as a batch instrument (batch time < 5s), it is recommended to set it as prompt as possible according to the plant requirements, choosing the **batching setup** for the automatic parameter optimization of the quick start menu. It is also recommended to disactivate the function 3.1, AC filter.

ALARM MESSAGES

CAUSES AND ACTIONS TO BE TAKEN

Messages	ERRORS	ACTION TO TAKE
NO ALARMS	All works regularly	-----
MAX ALARM	The flow rate is higher than the maximum threshold set	Check the maximum flow rate threshold set and the process conditions
MIN ALARM	The flow rate is lower than the minimum threshold set	Check the minimum flow rate threshold set and the process conditions
FLOW RATE >FS	The flow rate is higher than the full scale value set on the instrument	Check the full scale value set on the instrument and the process conditions
PULSE/REQ>FS	The pulse generation output of the device is saturated and cannot generate the sufficient number of impulses	Set a bigger unit of volume or, if the connected counting device allows it, reduce the pulse duration value
EMPTY PIPE	The measuring pipe is empty or the detection system has not been properly calibrated	Check whether the pipe is empty or repeat the empty pipe calibration procedure
BATCH ALARM	Batch interrupted for the followings condition: <input type="checkbox"/> Timer batch expired before the end of the batch <input type="checkbox"/> Batch valve open and flow rate to zero for a time longer to the safety timer set <input type="checkbox"/> Batch valve closed and flow rate different from zero for a time longer than the safety timer set	Verify: <input type="checkbox"/> Presetting <input type="checkbox"/> System conditions
INPUT NOISY	The measure is strongly effected by external noise or the cable connecting the transmitter to the sensor is broken	Check the status of the cables connecting the sensor, the grounding connections of the devices and the possible presence of noise sources
EXCITATION FAIL	The coils or the cable connecting the sensor are interrupted	Check the connecting cables to the sensor
CURRENT LOOP OPEN	The 4-20mA output on board or the optional one are not correctly closed on a valid load	Verify the load is applied to the output (max 1000 ohm). To disable the alarm, set the "mA V.fault" value (menu alarm) to 0.
P.SUPPLY FAIL	Power supply different from that indicated on the label.	Verify that the power supply is with in the specifications indicated on the label

ERROR CODES

CODES	ERROR DESCRIPTIONS	ACTION TO TAKE
0001	Problem with watch-dog circuit	ADDRESSING TO SERVICE
0002	Wrong configuration work data in eeprom	
0004	Wrong configuration safety data in eeprom	
0008	Defective eeprom	
0010	Defective keyboard (one or more key are pushed during the test)	
0020	Power supply voltage (+3.3) is out of range	
0040	Power supply voltage (+13) is too low (<10V)	
0080	Power supply voltage (+13) it's too high (>14V)	
0200	Timeout calibration input (input circuit is broken)	
0400	Gain input stage is out of range	
0800	Interruption on the coils circuit	Check the status of the cables connecting the sensor to the transmitter
0C00	Cumulative alarm 0800 + 0400	See single codes 0800 and 0400 above.

APPENDIX: DISPLAY ROTATION PROCEDURE

Fixing screw of board
printed: 11.09.2016
freigegeben

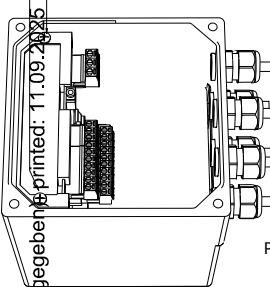

Pic.1

- ❑ Unscrew the screw as indicated in pic. 1

MAN 1000185580 ML Version: B Status: RL (release)

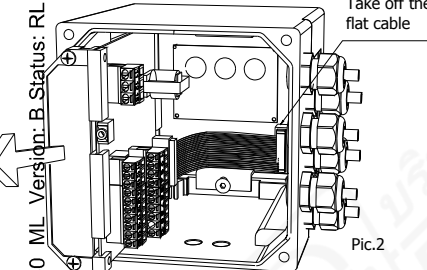

Pic.2

- ❑ Lift the board, remove the flat cable from the display (pic. 2) and completely extract the board from the box

4 mm hex spanner Display

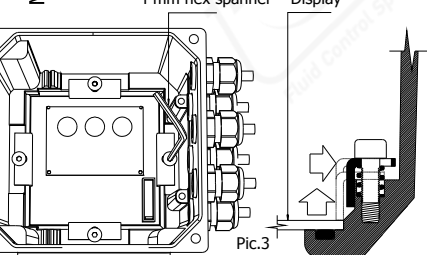

Pic.3

- ❑ Partially unscrew the screw fixing the display to allow the angular shift and extraction of the display

Note: Do not unscrew entirely the screw
Note: the display is rotatable ONLY in the aluminum IP67 version.

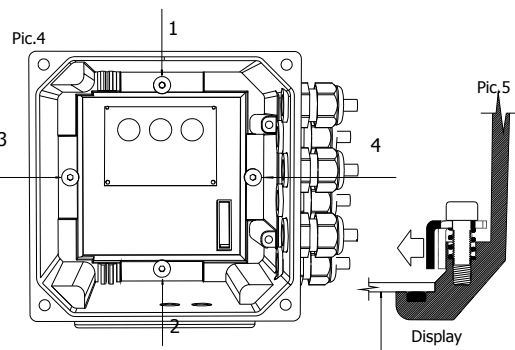

Pic.4

Pic.5

- ❑ Rotate the display to the desired location, verify the correct set of the seal, the cleaning of the contact surfaces it set the display housing.
- ❑ Place the fixing angles in the suitable positions (pic. 5) and screw down firmly until they make contact with the display housing.
- ❑ Screw up tightly the 4 screws (1, 2, 3, 4) indicated in pic. 4

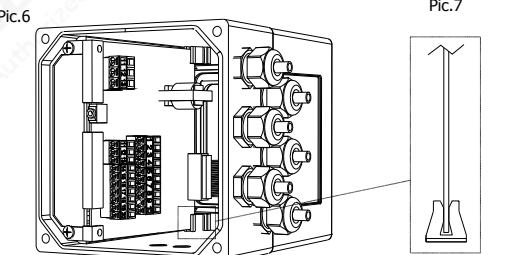

Pic.6

Pic.7

- ❑ Restore the flat cable connection to the display
- ❑ Verify the board is set correctly in the fixing clip (pic. 7)
- ❑ Fix the board to the box to complete the assembly process.