



Direct-acting 2/2-way plunger valve

- Gas valve with DVGW approval acc. to DIN EN 161, Class B
- Compact design
- Up to DN 25 and 150 mbar
- Body in brass
- Dirt filter in the inlet



Product variants described in the data sheet may differ from the product presentation and description.

Type description

Type 0293 switches without pressure difference from zero bar. The valve is especially good for switching low-pressure combustible gases. The direct-acting solenoid valve is delivered with circuit function A. It is normally closed. Upon switching, the magnetic core is tightened against the spring and the valve opens. A filter is built-in to the inlet. A dirt trap $\leq 500 \mu\text{m}$ (example our type TFU001) needs to be installed before the valve when using DN 25. This dirt trap needs to be accessible for maintenance.

FLU-TECH CO. LTD.



LINE OA WEBSITE

Email: sales@flutech.co.th **Website:** <https://flutech.co.th>

Tel: 02-384-6060, 086-369-5871-3 **Fax:** 02-384-5701 **LINE OA:** @flutech.co.th

Address (HQ): 845/3-4, Moo 3, Theparak Rd., T. Theparak, A. Mueang Samut Prakan, Samut Prakan, 10270, Thailand

Table of contents

1. General technical data	3
2. Circuit functions	3
3. Approvals and conformities	4
3.1. General notes	4
3.2. Conformity	4
3.3. Standards	4
3.4. Others	4
Fuel gases	4
4. Dimensions	5
5. Performance specifications	5
5.1. Power consumption	5
6. Ordering information	6
6.1. Bürkert eShop	6
6.2. Bürkert product filter	6
6.3. Bürkert Product Enquiry Form	6
6.4. Ordering chart	7
6.5. Ordering chart accessories	7
Cable plug Type 2518, form A according to DIN EN 175301 - 803 Note:	7
Strainer	7

DTS 1000204244 EN Version: G Status: RL (released | freigegeben | valide) printed: 24.01.2025



1. General technical data

Product properties	
Dimensions	Further information can be found in chapter "4. Dimensions" on page 5.
Material	
Seal	NBR
Body	Brass
Valve inner parts	Stainless steel
Special feature	Sieve in inlet, for DN 25 it is necessary to install a dirt filter, (max. 500 um) upstream of the valve, which is accessible during maintenance work, e.g. Type TFU001
Orifice	DN 20...DN 25
Circuit function	A Further information can be found in chapter "2. Circuit functions" on page 3.
Thermal insulation class of solenoid coil	Epoxy coil class H
Performance data	
Duty cycle	100 % continuous operation
Electrical data	
Operating voltage	230 V 50 Hz, 230 V UC
Voltage tolerance	± 10 %
Medium data	
Operating medium (for NBR)	Fuel gases of the 1st, 2nd and 3rd gas families
Medium temperature (for NBR)	- 15 °C...+ 60 °C
Process/Port connection & communication	
Electrical connection	Plug contacts according to DIN EN 175 301 - 803 form A for cable plug Type 2518 ▶ Further information can be found in chapter "Cable plug Type 2518, form A according to DIN EN 175301 - 803 Note:" on page 7 (supplied as standard).
Port connection	Threaded ports G 3/4 and G 1
Approvals and conformities	
Degree of protection	IP65 with cable plug
Others	Further information can be found in chapter "3.4. Others" on page 4.
Environment and installation	
Installation position	As required, preferably with actuator upright
Ambient temperature	- 15 °C...+ 60 °C
Accessories	
Strainer	Brass body Further information can be found in chapter "6.5. Ordering chart accessories" on page 7.

2. Circuit functions

Symbol	Description
	Circuit function A (CF A) 2/2-way solenoid valve Direct-acting Normally closed

3. Approvals and conformities

3.1. General notes

- The approvals and conformities listed below must be stated when making enquiries. This is the only way to ensure that the product complies with all required specifications.
- Not all available versions can be supplied with the below mentioned approvals or conformities.

3.2. Conformity

In accordance with the Declaration of Conformity, the product is compliant with the EU Directives.

3.3. Standards

The applied standards which are used to demonstrate compliance with the EU Directives are listed in the EU-Type Examination Certificate and/or the EU Declaration of Conformity.

3.4. Others

Fuel gases

Conformity	Description
	Fuel gases (valid for the variable code PO17) The products comply with: <ul style="list-style-type: none"> • Regulation (EU) 2016/426 – Appliances burning gaseous fuels and • DVGW DIN EN 161 (Automatic shut-off valves for gas burners and gas appliances)
	Optional: DIN EN 549:2023 - 07 certification The wetted valve seals are compliant with DIN EN 549:2023 - 07 (Rubber materials for seals and diaphragms for gas appliances and gas equipment) for medium temperatures of - 15 °C...+ 60 °C.

DTS 1000204244 EN Version: G Status: RL (released | freigegeben | valide) printed: 24.01.2025

4. Dimensions

Note:

Dimensions in mm

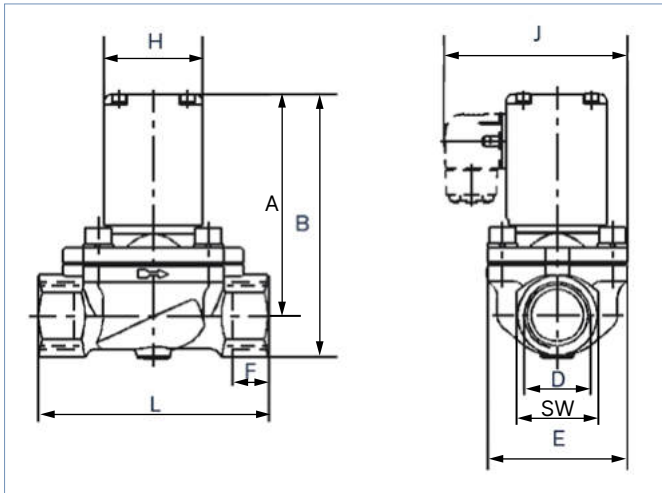

DN	D	A	B	E	F	H	J	L	SW
20	G 3/4	106	122	60	16	49	86.5	100	32
25	G 1	110.5	131	70	18	49	91.5	115	41

5. Performance specifications

5.1. Power consumption

Orifice [mm]	Port connection	K _v value water ¹⁾ [m ³ /h]	Weight [kg]	Pressure range ²⁾ [mbar]	Closing				Switching times ³⁾	
					Inrush		Hold		Opening [ms]	Closing [ms]
					AC [VA]	UC [W]	AC [VA/W]	UC [W]		
20	G 3/4	5.0	1.3	0...150	100...120	100	25/16	9	130...250	120...150
25	G 1	10.0	1.7	0...150	100...120	100	25/16	9	130...250	120...150

1.) Measurement at +20 °C, 1 bar pressure at valve inlet and free outlet

2.) Pressure data: overpressure to atmospheric pressure

3.) Measurement at +20 °C, 150 mbar at the valve inlet and free outlet, opening: pressure build-up 0...90 %, closing: pressure reduction 100...10 %
With UC coil, depending on duty cycle and ambient temperature max. 15 switchings/min.

DTS 1000204244 EN Version: G Status: RL (released | freigegeben | validé) printed: 24.01.2025

6. Ordering information

6.1. Bürkert eShop



Bürkert eShop – Easy ordering and quick delivery

You want to find your desired Bürkert product or spare part quickly and order directly? Our online shop is available for you 24/7. Sign up and enjoy all the benefits.

[Order online now](#)

6.2. Bürkert product filter



Bürkert product filter – Get quickly to the right product

You want to select products comfortably based on your technical requirements? Use the Bürkert product filter and find suitable articles for your application quickly and easily.

[Try out our product filter](#)

6.3. Bürkert Product Enquiry Form

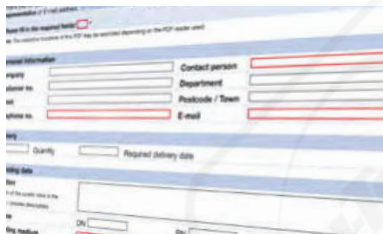

Bürkert Product Enquiry Form – Your enquiry quickly and compactly

Would you like to make a specific product enquiry based on your technical requirements? Use our Product Enquiry Form for this purpose. There you will find all the relevant information for your Bürkert contact. This will enable us to provide you with the best possible advice.

[Fill out the form now](#)

DTS 1000204244 EN Version: G Status: RL (released | freigegeben | validé) printed: 24.01.2025

6.4. Ordering chart

Note:

- Further versions are available on request.
- All of the following valves are valves with brass bodies and cable plugs.

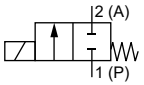
Circuit function	Port connection	Orifice	Q _{Nn} value air	K _v value water	Voltage/ frequency	Pressure range	Seal material	Weight	Remarks	Article no.
		[mm]	[l/min]	[m ³ /h]	[V/Hz]	[mbar]		[kg]		
CF A 2/2-way solenoid valve Direct-acting Normally closed 	G 3/4	20.0	5400	5.0	230/50	0...150	NBR	230/50	–	279478 ☞
	G 3/4	20.0	5400	5.0	230/UC ¹⁾	0...150	NBR	230/UC ¹⁾	noise reduced	279479 ☞
	G 1	25.0	10800	10.0	230/50	0...150	NBR	230/50	–	256321 ☞
	G 1	25.0	10800	10.0	230/UC ¹⁾	0...150	NBR	–	noise reduced	279480 ☞

1.) Electric versions (UC) with integrated rectifier

6.5. Ordering chart accessories

Cable plug Type 2518, form A according to DIN EN 175301 - 803 Note:

- Dimensions in mm
- For further versions see data sheet **Type 2518** ▶

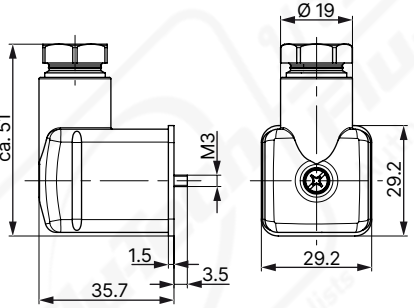
Cable plug	Dimensions	Version	Voltage	Article no.
		Without circuitry (AC/DC)	0...250 V AC/DC	314802 ☞
		With LED (AC/DC)	12...24 V AC/DC	314812 ☞
		With LED and varistor (AC/DC)	12...24 V AC/DC	314820 ☞
		With rectifier, LED and varistor	12...24 V AC/DC	314816 ☞
		Without circuitry (AC/DC) with silicone seal for higher ambient temperature, e.g. steam version (NA07)	0...250 V AC/DC	361687 ☞

Strainer

Note:

The dirt trap prevents malfunctions and extends the service life of downstream valves, see **data sheet Type TFU001** ▶.

Port connection	Orifice	K _v value flow range	Pressure level PN	Sieve	Article no.
	[mm]	[m ³ /h]	[bar]	[µm]	
G 3/4	20.0	7.85	20	400	783673 ☞
G 1	25.0	11.08	20	400	783674 ☞

DTS 1000204244 EN Version: G Status: RL (released | freigegeben | validé) printed: 24.01.2025