

SDL1 Liquid Leakage Sensor



Introduction

The leakage sensor uses the principle of light reflection to detect leakages, and comprises of infrared luminous parts, infrared light receiving parts, and prisms. It can detect leakages on stainless steel plates, plastic plates, and wooden boards. It is small, reacts fast, highly sensitive, and retracts immediately after contacting the liquid.

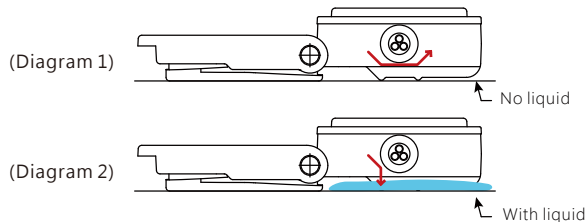

Diagram 1, the medium is air (no liquid).
The light is completely reflected to the sensor.
Diagram 2, the medium is liquid.
The light penetrates the plastic.

Application

Semiconductor process equipment, exposure devices, lithography machines, cleaning equipment, medical equipment, printing machines, etc.

Product Features

- The optical type can measure a variety of liquids and is unaffected by external ambient light.
- Easy installation with a base and lock mechanism.
- Easier to maintain compared to resistive detection tape or paper-absorbing type. Simply dry the detection surface and re-install it back.
- PFA material can be used, suitable for acid, alkali, liquid medicine, pure water, and other liquids.
- The product has an indicator light, which can immediately signal the action status.
- Complete output type selection, NPN or PNP type.
- Comply with IP67.
- Comply with lead-free standards and CE certified.
- Comply with UL certification.

Specifications

Model	Normal type	UL certification (E324746)
Detection method	Infrared optical	
Standard detection object	water	
Power supply	12 ~ 24 VDC	
Current consumption	Max.30 mA(No Load);Max 80mA(Full Load)	
Output type	3-wire NPN	
	3-wire PNP	
Action type	NO when normal, NC when leakage is detected.	
	NC when normal, NO when leakage is detected.	
Max. current output	50 mA	
Max. voltage output	30 VDC,With 3-Wire NPN	
	24VDC With 3-Wire PNP	
Residual voltage output	Max. 1V @ 50 mA	
Circuit protection	Power supply reverse connection protection, short circuit protection	

Model	Normal type	UL certification (E324746)
Indicator light	The green light is on when normal. The red light is on when leakage is detected.	
Operating temp.	-20 ~ 80 °C (no freezing)	-20 ~ 60 °C (no freezing)
Working humidity	30 ~ 85%RH (no freezing)	
Storage temp.	-40 ~ 80 °C (no freezing)	
Storage humidity	30 ~ 85%RH (no freezing)	
Protection level	IP67	IP67(Not UL certificated)
Connection method	Outlet type, 3-core cable, length 2.2m or more	
Material	Body: PFA. Cable: PFA-coated. Mounting base: PFA. PFA: Suitable for acid, alkaline liquid, IPA (isopropanol), pure water.	
	Body: PP. Cable: PVC/XLPE Mounting base: PP.	Body: PP. Cable: XLPE Mounting base: PP.
Fixed method	You can choose the configuration according to the material requirements (PP, PFA...etc.)	

Ordering Instructions

SDL 1 0 0 07 08 - **0** 10 11 12 13 14 15 16 17 18 19

⑦⑧ Certification
 00: None
 3A: UL

⑩ Output
 P: 3-wire PNP, 12~24VDC
 N: 3-wire NPN, 12~24VDC

⑪ Contact
 A: NO
 B: NC

⑫⑬ Body Material
 14: PFA
 18: PP

⑭⑮ Cable Cover
 00: No coating
 14: PFA casing

⑯⑰⑱ Total Length

Code	Cable Length
2200	2200 mm

External Size

(Unit:mm)

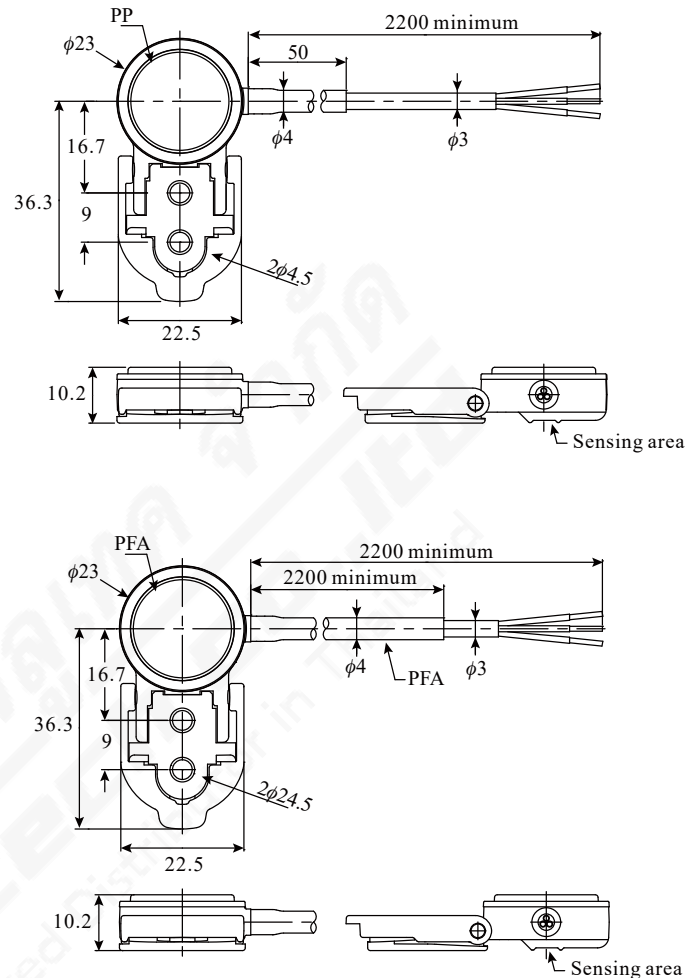

※ Comply with UL certification.

Mounting base or fastening ring

Code	Material	Material	Note
SDLAM1P-B118C00001	PP	Type A Mounting base 23.1*21.9	With PP main body
SDLAM1P-B218C00001	PP	Type A fastening ring 26.6*22.5	With PP main body
SDLAM1P-B114C00001	PFA	Type B Mounting base 23.1*21.9	With PFA main body
SDLAM1P-B214C00001	PFA	Type B fastening ring 26.6*22.5	With PFA main body



FLU-TECH CO. LTD.

Email: sales@flutech.co.th Website: <https://flutech.co.th>

Tel: 02-384-6060, 086-369-5871-3 Fax: 02-384-5701 LINE OA: @flutech.co.th

Address (HQ): 845/3-4, Moo 3, Theparak Rd., T. Theparak, A. Mueang Samut Prakan, Samut Prakan, 10270, Thailand