



Radar filling level meter for liquids and bulk solids

- Suitable for simple applications such as water treatment, storage tanks and small silos
- Continuous filling level measurement up to 20 m, 4...20 mA, 2-wire
- Available process connections: thread (G, NPT, R 1½")
- Excellent radar signal focusing and high measurement dynamics
- Adjustable via Bluetooth

Product variants described in the data sheet may differ from the product presentation and description.

Can be combined with

| | | |
|---|---|---|
|  | Type 8619 multiCELL – multi-channel/ multi-function transmitter/ controller | ▶ |
|  | Type 8692 Digital electro-pneumatic positioner for integrated mounting on process control valves | ▶ |
|  | Type 8647 AirLINE SP – electropneu- matic automation system | ▶ |
|  | Type ME44 I/O module, IP 20 | ▶ |

Type description

The device Type 8131 is a non-contact radar level meter, ideal for continuous level measurement of liquids and bulk solids in basic applications. It is particularly suitable for storage tanks, water treatment applications (open channel measurement) as well as through plastic tanks. For solids, it can be used in small silos or open tanks.

The radar level meter, available in 1½" with G, NPT or R connection, is equipped with a plastic housing and a plastic integrated antenna.

The excellent focus of the radar signal and the high measurement dynamics allow excellent measurement results even in small, narrow and high containers, as the risk of signal interference by installations, constructions and vessel walls is significantly reduced. Signal damping, e.g. due to signal length, foaming or low dielectric constant values of liquids, becomes much less important.



Table of contents

| | |
|--|-----------|
| 1. General technical data | 3 |
| <hr/> | |
| 2. Approvals and conformities | 6 |
| 2.1. General notes | 6 |
| 2.2. Conformity | 6 |
| 2.3. Standards | 6 |
| 2.4. Explosion protection..... | 6 |
| 2.5. North America (USA/Canada) | 7 |
| 2.6. Foods and beverages/Hygiene | 7 |
| <hr/> | |
| 3. Materials | 7 |
| 3.1. Bürkert resistApp | 7 |
| <hr/> | |
| 4. Dimensions | 8 |
| <hr/> | |
| 5. Performance specifications | 9 |
| 5.1. Measurement deviation diagram | 9 |
| Variant 0...10 m | 9 |
| Variant 0...20 m | 9 |
| <hr/> | |
| 6. Product installation | 9 |
| <hr/> | |
| 7. Product operation | 10 |
| 7.1. Measuring principle | 10 |
| 7.2. Product operation notes..... | 10 |
| Operating techniques | 10 |
| <hr/> | |
| 8. Product accessories | 11 |
| <hr/> | |
| 9. Ordering information | 12 |
| 9.1. Bürkert eShop | 12 |
| 9.2. Bürkert product filter | 12 |
| 9.3. Ordering chart | 12 |

DTS 1000646693 EN Version: B Status: RL (released | freigegeben | validé) printed: 28.02.2025

1. General technical data

Product properties

Material

Make sure the device materials are compatible with the fluid you are using.
Further information can be found in chapter [“3.1. Bürkert resistApp” on page 7.](#)

Non-wetted parts

| | |
|---------|--|
| Cover | PBT (polyester) |
| Housing | PBT (polyester) |
| Seal | Between housing and cover: silicone O-ring Cable gland seal: EPDM |

| | |
|-------------|----|
| Cable gland | PA |
| Blind plug | PA |

Wetted parts

| | |
|--------------------|-----------|
| Process connection | PVDF |
| Antenna | PVDF |
| Seal ¹⁾ | FKM, EPDM |

Dimensions Further information can be found in chapter [“4. Dimensions” on page 8.](#)

Weight Approx. 0.7 kg

Measured quantity Distance between the end of the sensor antenna and the product surface. The edge of the antenna is also the measurement reference level.

Beam angle²⁾ 8°

Measuring range

- 0...10 m depending on application and medium (recommended measuring range 0...5 m with bulk solids)
- 0...20 m depending on application and medium (recommended measuring range 0...10 m with bulk solids)

Damping (63 % of the input variable) 0...999 s, adjustable

Operating mode The configurable operating mode depends on the country in which the device is used.

- Mode 1: EU, Albania, Andorra, Azerbaijan, Australia, Belarus, Bosnia and Herzegovina, Canada, Liechtenstein, Moldavia, Monaco, Montenegro, New Zealand, Northern Macedonia, Norway, San Marino, Saudi Arabia, Serbia, South-Africa, Switzerland, Turkey, Ukraine, United Kingdom, USA
- Mode 2: South Korea, Taiwan, Thailand
- Mode 3: India, Malaysia
- Mode 4: Russia, Kazakhstan

Performance data

Blocking distance Depending on the operating conditions

- Operating mode 1, 2 and 4: 0 mm
- Operating mode 3: ≥ 250 mm

Measuring range resolution 1 mm

Measurement deviation According to EN 60770-1

- Variant 0...10 m: ≤ 5 mm for liquids (measuring distance > 0.25 m)
- Variant 0...20 m: ≤ 2 mm for liquids (measuring distance > 0.25 m)

Further information can be found in chapter [“5.1. Measurement deviation diagram” on page 9.](#)

Non-repeatability³⁾

- Variant 0...10 m: ≤ 5 mm
- Variant 0...20 m: ≤ 2 mm

Measuring frequency W-Band (80 GHz technology)

Measuring cycle time⁴⁾ ≤ 250 ms

Step response time^{4) 5)} ≤ 3 s

Temperature drift $< 0.03\%/10K$ or max. 0.3 % related to the 16.7 mA span

Electrical data

Operating voltage (U_n) 12...35 V DC
Connection to main supply: permanent

| | |
|--|---|
| Power source (not supplied) | Limited energy circuit (power max. 100 W) according to IEC 61010-1, e.g.: <ul style="list-style-type: none"> • Class 2 power supply unit (according to UL1310) • SELV power supply unit (safety extra-low voltage) with suitable internal or external limitation of the output current • PELV power supply unit (protective low voltage) with suitable internal or external limitation of the output current |
| DC reverse polarity protection | Yes |
| Residual ripple (at DC) | <ul style="list-style-type: none"> • For $12\text{ V} < U_n < 18\text{ V}$: $\leq 0.7 V_{\text{eff}}$ (16...400 Hz) • For $18\text{ V} < U_n < 35\text{ V}$: $\leq 1.0 V_{\text{eff}}$ (16...400 Hz) |
| Overvoltage category according to IEC 61010-1 | Category III |
| Protection class according to IEC 61010-1 | Class III |
| Starting current | $\leq 3.6\text{ mA}$; $\leq 10\text{ mA}$ for 5 ms after switching on |
| Load resistor | $(U_n - U_{\text{min}})/0.022\text{ A}$ |
| Output | <ul style="list-style-type: none"> • Variant 0...10 m: 4...20 mA • Variant 0...20 m: 4...20 mA/HART |
| Output signal range | <ul style="list-style-type: none"> • Variant 0...10 m: 3.8...20.5 mA (default setting) • Variant 0...20 m: 3.8...20.5 mA/HART (default setting) |
| Signal resolution | 0.3 μA |
| Output current | Max. 22 mA |
| Fault signal | Current output: mA value unchanged, $\geq 21\text{ mA}$ or $\leq 3.6\text{ mA}$ (adjustable) |
| Voltage supply cable | <ul style="list-style-type: none"> • Cable diameter: 4.5...9 mm • Wire cross-section: <ul style="list-style-type: none"> – Massive wire, stranded wire: 0.2 mm² (AWG 24)...2.5 mm² (AWG 14) – Stranded wire with end sleeve: 0.2 mm² (AWG 24)...1.5 mm² (AWG 16) |
| Medium data | |
| Process temperature ^{6.)} | <ul style="list-style-type: none"> • Variant 0...10 m: - 40...+ 60 °C (- 40...+ 140 °F) • Variant 0...20 m: - 40...+ 80 °C (- 40...+ 176 °F) |
| Process pressure ^{6.)} | Vessel pressure: - 1...3 bar (- 100...300 kPa/- 14.5...43.5 psig) |
| Process/Pipe connection and communication | |
| Process connection | G, NPT or R 1½" thread |
| Electrical connection | Cable gland M20 × 1.5 |
| Wireless communication: Bluetooth | |
| Communication interface | Bluetooth radio V5.0, downward compatible with V4.0 |
| System requirements | <ul style="list-style-type: none"> • For smartphone/tablet: <ul style="list-style-type: none"> – Operating system: iOS 13 or newer – Operating system: Android 5.1 or newer – Bluetooth: 4.0 LE or newer • For PC/notebook <ul style="list-style-type: none"> – Operating system: Windows 10 or newer – DTM Collection: 10/2020 or newer – Bluetooth: 4.0 LE or newer |
| Frequency | 2.402...2.480 GHz |
| Emitted power | Max. + 2.2 dBm |
| Number of participants | Max. 1 |
| Typical effective range | 25 m (82 ft) ^{7.)} |
| Approvals and conformities | |
| Directives | |
| CE directive | Further information on the CE Directive can be found in chapter "2.3. Standards" on page 6. |
| NAMUR recommendation | <ul style="list-style-type: none"> • NE21 - Electromagnetic compatibility of equipment • NE43 - Signal level for fault information from measuring transducers • NE53 - Compatibility of field devices and display/adjustment components • NE107 - Self-monitoring and diagnosis of field devices |
| Explosion protection | ATEX/IECEx ^{8.)} (only variant 0...20 m): EN IEC 60079-0:2018, IEC 60079-26:2015, EN 60079-11:2012 Further information can be found in chapter "2.4. Explosion protection" on page 6. |

DTS 1000646693 EN Version: B Status: RL (released | freigegeben | validé) printed: 28.02.2025

| | |
|-----------------------------|---|
| North America (USA/Canada) | On request <ul style="list-style-type: none"> • CSA ordinary location • FM (Factory Mutual) ordinary location Further information can be found in chapter "2.5. North America (USA/Canada)" on page 7. |
| Foods and beverages/Hygiene | On request <ul style="list-style-type: none"> • FDA declaration of conformity^{8.)} • 1935/2004/EC declaration^{8.)} Further information can be found in chapter "2.6. Foods and beverages/Hygiene" on page 7. |
| Others | Radio licenses ^{8.)} : Europe (in EC declaration), New Zealand, USA, South Korea, Australia, Canada, Brazil, Malaysia, Serbia, Japan, Thailand, India, Taiwan, Morocco, Ukraine, South Africa |

Environment and installation

| | |
|--|---|
| Ambient temperature | <ul style="list-style-type: none"> • Operation: <ul style="list-style-type: none"> – Variant 0...10 m: - 40...+ 60 °C (- 40...+ 140 °F) – Variant 0...20 m: - 40...+ 70 °C (- 40...+ 176 °F) • Storage and transport: - 40...+ 80 °C (- 40...+ 176 °F) |
| Relative air humidity | Max. 95 % |
| Height above sea level | Max. 5000 m |
| Degree of protection according to IEC/EN 60529 | IP66/IP67 with M20 × 1.5 cable plug mounted and tightened |
| Pollution degree | Degree 4 (when used with fulfilled housing protection) |

- 1.) Only with G thread, EPDM on equipment with food/pharmaceutical certificate
- 2.) Outside the specified beam angle, the energy level of the radar signal is 50 % (- 3 dB) less.
- 3.) Already included in the measurement deviation
- 4.) With operating voltage $U_n \approx 24$ V DC
- 5.) Time span after a sudden measuring distance change from 1...5 m, until the output signal has taken for the first time 90 % of the final value (IEC 61298-2).
- 6.) Observe the specifications on the type label. It indicates the respective lowest value to be applied.
- 7.) Depending on the local conditions
- 8.) Approval of VEGAPULS 11 or VEGAPULS 21 product range from VEGA

DTS 1000646693 EN Version: B Status: RL (released | freigegeben | validé) printed: 28.02.2025

2. Approvals and conformities

2.1. General notes

- The approvals and conformities listed below must be stated when making enquiries. This is the only way to ensure that the product complies with all required specifications.
- Not all available versions can be supplied with the below mentioned approvals or conformities.



2.2. Conformity

In accordance with the Declaration of Conformity, the product is compliant with the EU Directives.

2.3. Standards

The applied standards which are used to demonstrate compliance with the EU Directives are listed in the EU-Type Examination Certificate and/or the EU Declaration of Conformity.

2.4. Explosion protection

| Approval | Description |
|---|---|
|   | <p>Optional: Explosion protection¹⁾ Ex marking of the components according to:</p> <p>ATEX: KIWA 19ATEX0028X</p> <ul style="list-style-type: none"> • II 1G, 1/2G Ex ia IIC T4 Ga, Ga/Gb <p>IECEx: IECEx KIWA 19.0015X</p> <ul style="list-style-type: none"> • Ex ia IIC T4...T1 Ga or Ga/Gb <p>UKEx: UL21UKEX2284X Rev. 1</p> <ul style="list-style-type: none"> • II 1G, 1/2G Ex ia IIC T4 Ga or Ga/Gb <p>c-FM-us: FM20CA0003X</p> <ul style="list-style-type: none"> • CI I, Div 1, Gp ABCD T4; CI I, Zn 0, 0/1 Ex ia IIC T4 Ga or Ga/Gb <p>c-CSA-us: Certificate: 80000123</p> <ul style="list-style-type: none"> • Class I, Division 1, Groups A, B, C, D; Class II, Division 1, Groups E, F, G; Class III T4 Ex ia IIC T4 Ga, GaGb Class I, Zone 0, 0/1 AEx ia IIC T4 Ga, Ga/Gb <p>Any unauthorized modifications made to the device will invalidate the Ex-certification.</p> |

1.) Approval of VEGAPULS 11 or VEGAPULS 21 product range from VEGA

DTS 1000646693 EN Version: B Status: RL (released | freigegeben | validé) printed: 28.02.2025

2.5. North America (USA/Canada)

| Approval | Description |
|----------|---|
| | <p>Optional: CSA ordinary location¹⁾ for Canada and the USA The products are CSA approved for Canada and the USA according to:</p> <ul style="list-style-type: none"> • CAN/CSA-C22.2 No. 61010-1-12 • UL 61010-1 (ELECTRICAL EQUIPMENT FOR MEASUREMENT, CONTROL, AND LABORATORY USE – Part 1: General Requirements) <p>Certificate: 80001942</p> |
| | <p>Optional: FM (Factory Mutual) ordinary location¹⁾ The products are FM approved for the USA and Canada according to:</p> <ul style="list-style-type: none"> • FM Class 3810, ANSI/UL 61010-1, ANSI/UL 50E and ANSI/IEC 60529:R Certificate: FM19NUS0009 • CAN/CSA-C22.2 No. 61010-1, CSA-C22.2 No. 94.2 and CAN/CSA-C22.2 No. 60529 Certificate: FM19NCA0004 <p>The products are suitable for use in ordinary (non-hazardous) locations, indoor and outdoor, with degree of protection IP66/67 or IP66/68 (IPX8@ 3 bar, 24 hr) as well as Type 4X and Type 6P.</p> |

1) Approval of VEGAPULS 11 or VEGAPULS 21 product range from VEGA

2.6. Foods and beverages/Hygiene

| Conformity | Description |
|------------|--|
| <p>FDA</p> | <p>FDA¹⁾ – Code of Federal Regulations The devices comply in their composition with the Code of Federal Regulations published by the FDA (Food and Drug Administration, USA).</p> |
| | <p>EC Regulation 1935/2004¹⁾ of the European Parliament and of the Council All wetted materials are compliant with EC Regulation 1935/2004 according to the manufacturer's declaration.</p> |

1) Approval of VEGAPULS 11 or VEGAPULS 21 product range from VEGA

3. Materials

3.1. Bürkert resistApp

Bürkert resistApp – Chemical resistance chart

You want to ensure the reliability and durability of the materials in your individual application case? Verify your combination of media and materials on our website or in our resistApp.

Start chemical resistance check

DTS 1000646693 EN Version: B Status: RL (released | freigegeben | validé) printed: 28.02.2025

4. Dimensions

Note:

Dimensions in mm, unless otherwise stated

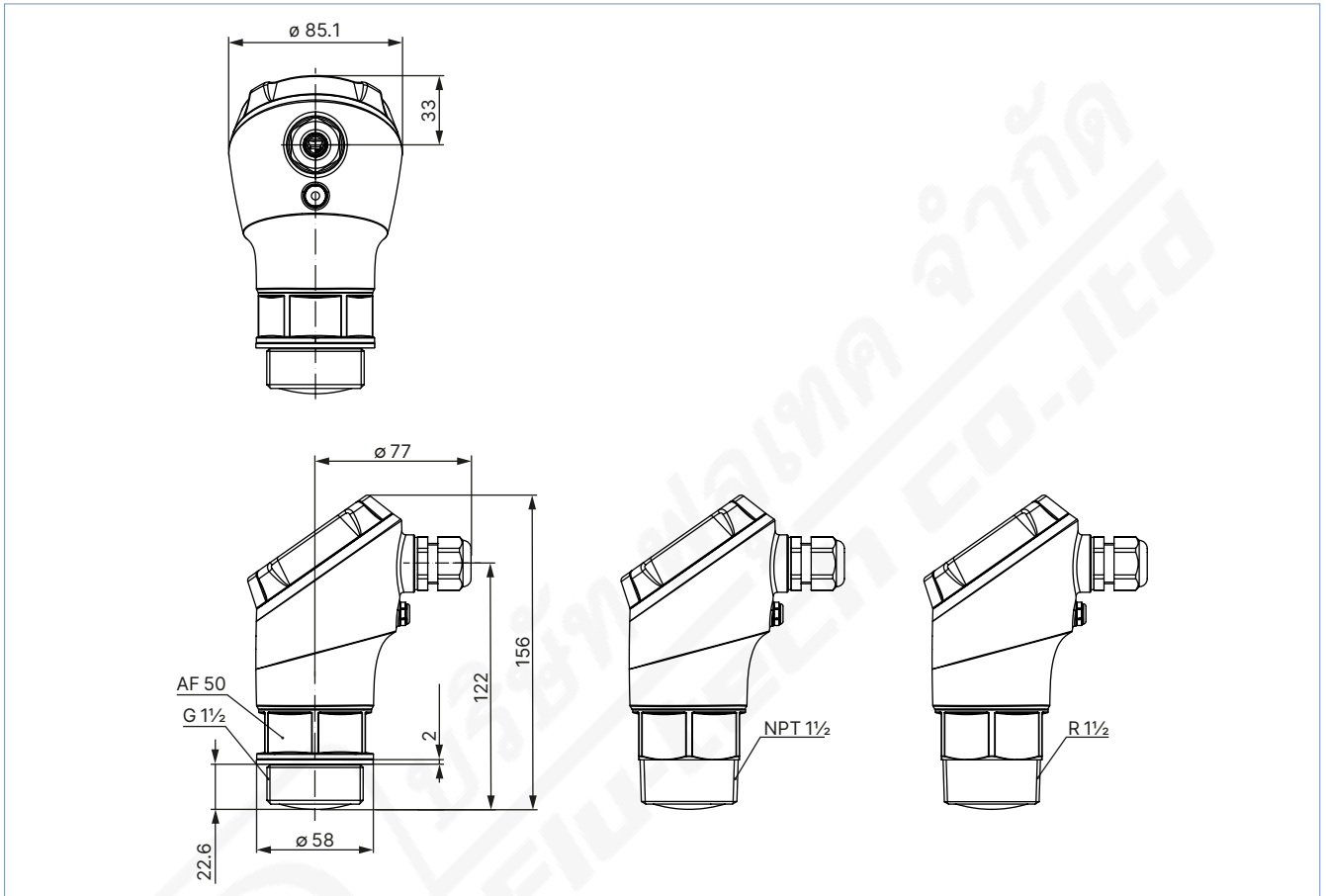

5. Performance specifications

5.1. Measurement deviation diagram

The following drawings show the measurement deviation of Type 8131 according to the variant under the following process reference conditions according to EN 61298-1:

- Temperature: + 18...+ 30 °C (+ 64...+ 86 °F)
- Relative humidity: 45...75 %
- Air pressure: 860...1060 mbar
- Installation reference conditions:
 - Distance to installations: > 200 mm
 - Reflector: flat plate reflector
 - False reflections: biggest interfering signal, 20 dB smaller than the useful signal

In case of deviations from reference conditions, the installation-related offset can be up to ± 4 mm. This offset can be compensated by the adjustment.

Variant 0...10 m

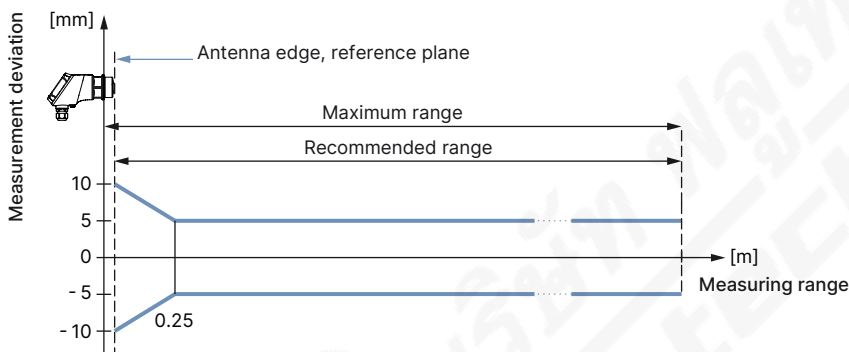

Variant 0...20 m

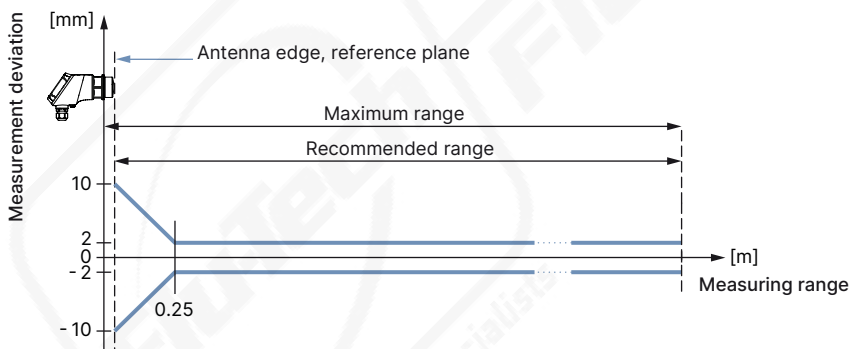

6. Product installation

The Type 8131 level meter can be screwed directly onto a tank. However, threaded flanges, weld-on threaded connections or hygienic threaded adapters for simple adaptation to the process connection of the device with threaded connection are available as accessories. Adjustable brackets or swivel-head brackets are also available, allowing the instrument to be easily mounted on a wall or ceiling. Particularly in the case of open channels, this is a simple and effective way of aligning the sensor with the liquid surface.

Further information on accessories can be found in chapter **“8. Product accessories”** on page 11.

7. Product operation

7.1. Measuring principle

The radar measuring device for the measurement of liquid or bulk solids levels consists of a housing with electronics and a process connection with antenna. The lens-shaped antenna of the radar sensor emits a continuous, frequency-modulated radar signal. This is reflected by the liquid or bulk solids surface and received by the antenna as an echo. Radar waves propagate at the speed of light. The frequency difference between the transmitted and received signal is determined by special algorithms in the sensor electronics. The filling level is calculated, converted into a corresponding output signal and transmitted as a measured value.

The measuring range of the radar level measuring device Type 8131 begins physically at the end of the antenna.

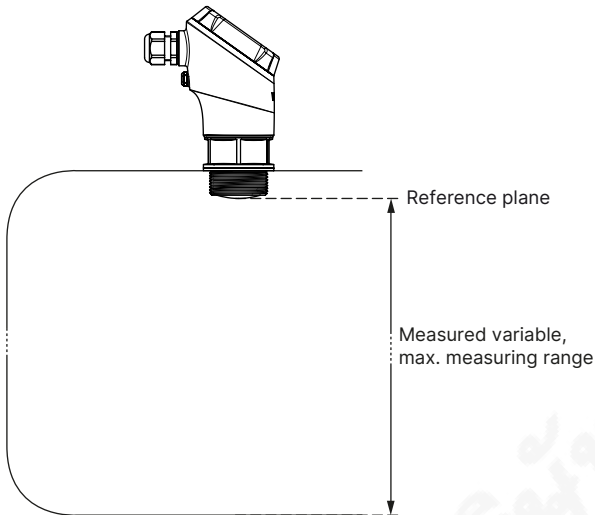

7.2. Product operation notes

Operating techniques

Devices with integrated Bluetooth module can be adjusted wirelessly via standard adjustment tools:

- Smartphone/tablet (iOS or Android operating system)
- PC/notebook with Bluetooth USB adaptor (Windows operating system)



| Wireless connection to standard operating devices | Description |
|---|---|
| | 1 Radar filling level meter |
| | 2 Smartphone/tablet |
| | 3 PC/notebook with Bluetooth USB adaptor |
| Operation is via a free app from the "Apple App Store", the "Google Play Store" or the "Baidu Store". Alternatively, adjustment can also be carried out via PACTware/DTM and a Windows PC. | |

DTS 1000646693 EN Version: B Status: RL (released | freigegeben | validé) printed: 28.02.2025

8. Product accessories

Note:

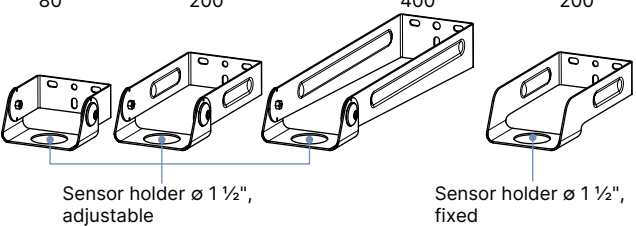
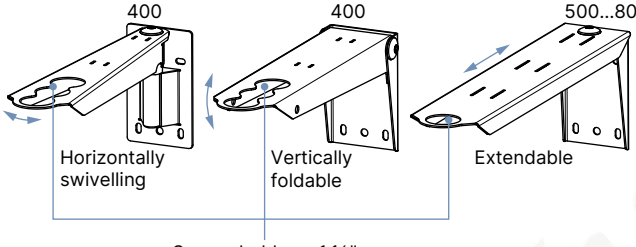
The following accessories are available on request. Contact your Bürkert sales office.

| Accessory | Description |
|---|--|
| <p>Length [mm] to sensor center:</p> <p>80 200 400 200</p>  | <p>Mounting bracket for wall mounting:</p> <ul style="list-style-type: none"> length 80 or 200 mm, with Ø 1½" adjustable sensor holder length 200 mm, with Ø 1½" fixed sensor holder |
| <p>Length [mm] to sensor center:</p> <p>400 400 500...800</p>  | <p>Mounting bracket for wall mounting with Ø 1½" sensor holder:</p> <ul style="list-style-type: none"> horizontally swivelling, length 400 mm vertically foldable, length 400 mm extendable, length 500...800 mm |
|  | <p>Adaptor flange</p> <ul style="list-style-type: none"> DN 50 PN 10 DN 80 PN 6 DN 100 PN 6 |
|  | <p>Hygienic adaptor (G 1½")</p> <ul style="list-style-type: none"> Clamp 2", 2½", 3", 4" DIN 32676, ISO 2852 Aseptic DN 50, DN 65, DN 80 PN 2 DIN 11851 |

DTS 1000646693 EN Version: B Status: RL (released | freigegeben | validé) printed: 28.02.2025

9. Ordering information

9.1. Bürkert eShop



Bürkert eShop – Easy ordering and quick delivery

You want to find your desired Bürkert product or spare part quickly and order directly? Our online shop is available for you 24/7. Sign up and enjoy all the benefits.

[Order online now](#)

9.2. Bürkert product filter



Bürkert product filter – Get quickly to the right product

You want to select products comfortably based on your technical requirements? Use the Bürkert product filter and find suitable articles for your application quickly and easily.

[Try out our product filter](#)

9.3. Ordering chart

| Measuring range [m] | Operating voltage [V DC] | Process connection | Output | Approvals and conformities | | | Electrical connection | Article no. |
|------------------------|-----------------------------|--------------------|---------------------|----------------------------|-----|--------------|-----------------------|-------------|
| | | | | Ex protection | FDA | ECR1935/2004 | | |
| 0...10 | 12...35 V DC | G 1½ | 4...20 mA (2 wires) | No | No | No | Cable gland M20 × 1.5 | 575830 |
| | | NPT 1½ | | | | | | 575831 |
| | | R 1½ | | | | | | 575832 |
| 0...20 | 12...35 V DC | G 1½ | 4...20 mA (2 wires) | No | No | No | Cable gland M20 × 1.5 | 575833 |
| | | NPT 1½ | | | | | | 575834 |
| | | R 1½ | | | | | | 575835 |
| | | G 1½ | Yes | No | No | 575836 | | |
| | | NPT 1½ | | | | 575837 | | |
| | | R 1½ | | | | 575838 | | |
| | | G 1½ | No | Yes | Yes | 575839 | | |
| | | NPT 1½ | | | | 575840 | | |
| | | R 1½ | | | | 575841 | | |

Further variants on request

| | |
|--|--|
| | <p>Approval</p> <ul style="list-style-type: none"> • CCOE/NEPSI/KTL/TIIS • INMETRO/IA • NSF/ANSI/CAN61/WRAS for variant with measuring range of 0...20 m |
|--|--|

DTS 1000646693 EN Version: B Status: RL (released | freigegeben | validé) printed: 28.02.2025