



บริษัท ฟลูเทค จำกัด  
**Flu-tech co.,ltd**  
Authorized Distributor in Thailand



# The ROSS<sup>®</sup> Coaxial Valve

CV10

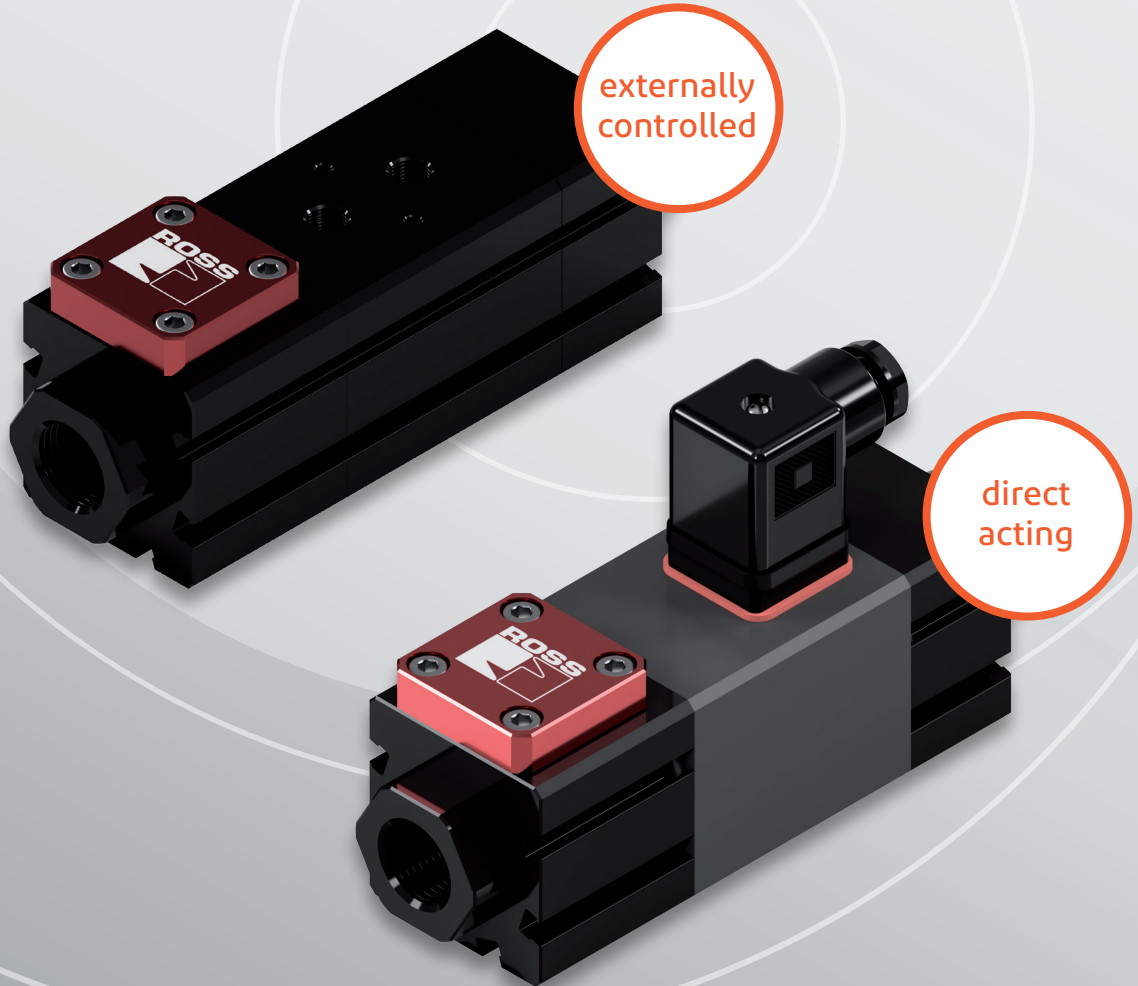

COAXIAL VALVES

# Coaxial Valve

## The valve for increased requirements

For decades, coaxial valves have been used successfully in many industrial sectors when it comes to implementing increased requirements in the field of fluid technology.

The main function of a coaxial valve is characterized by the fact that a control tube is moved in an horizontal direction by compressed air or magnetic force, thereby opening or closing the valve seat.

The ROSS coaxial valve includes direct operated Models in pressure and electrically controlled designs, 2/2 way and 3/2 way function.

### MAIN FEATURES

- 1 40% HIGHER FLOWRATE**
- 2 UP TO 4 TIMES LONGER LIFESPAN**
- 3 VALVE SEAT REPLACEMENT IN INSTALLED CONDITION**
- 4 APPLICATION AT INCREASED PRESSURE AND TEMPERATURE RANGE**

The special valve construction shows further advantages of the ROSS coaxial valve:

### BENEFITS

- fast opening and closing times
- very high flowrate
- insensitiv to dirt
- extremely durable and low-maintenance
- Valve seat replacement when installed, thus less production downtime
- variable use for all neutral gases, liquid, highly viscous, gelatinous and contaminated
- ROSS coaxial valves are also available as manifolds
- ROSS coaxial valves are available as special design



Model Series CV10 | COAXIAL VALVE

# The technology of the ROSS® coaxial valve in detail

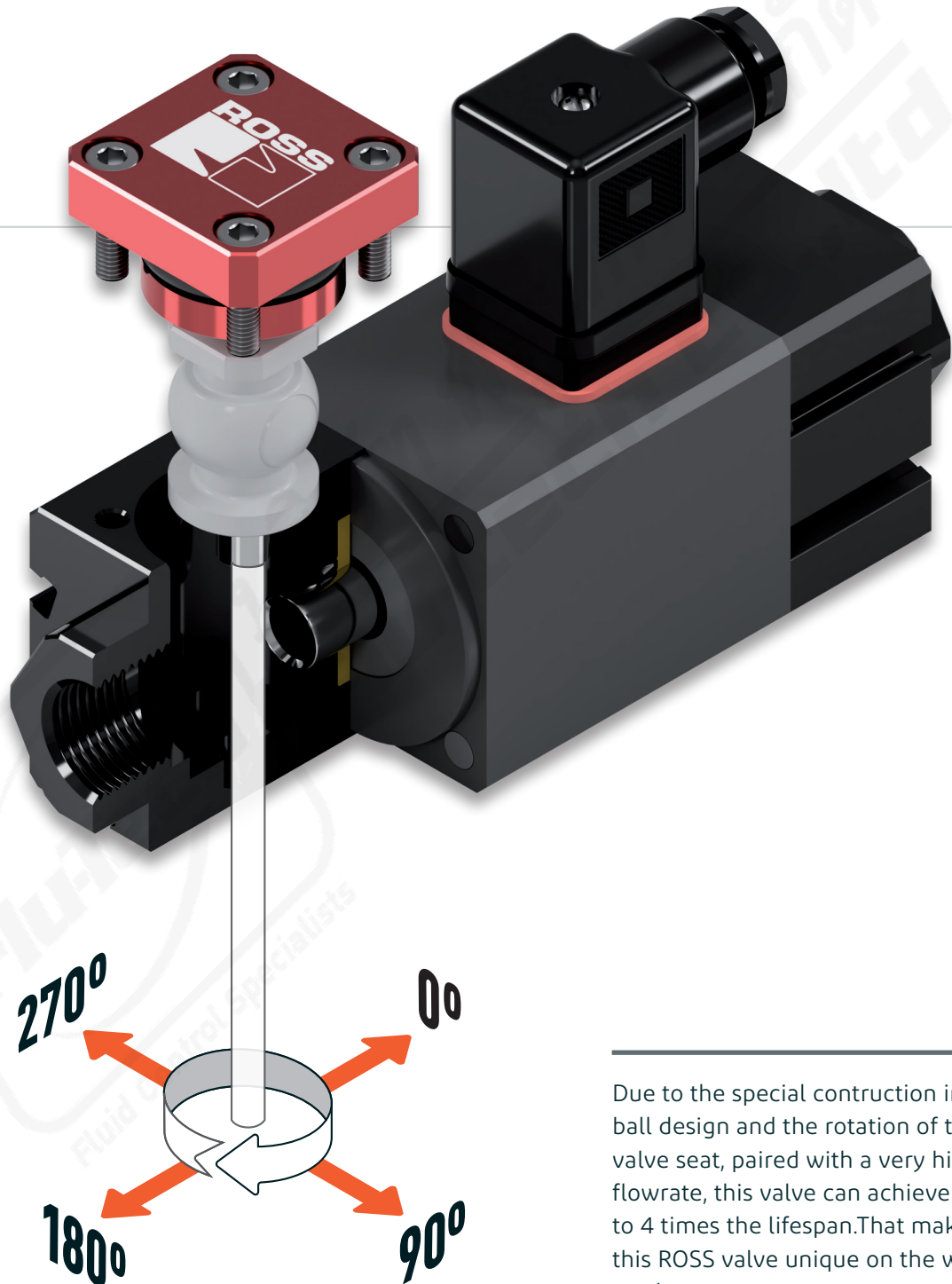

Due to the special construction in ball design and the rotation of the valve seat, paired with a very high flowrate, this valve can achieve up to 4 times the lifespan. That makes this ROSS valve unique on the world market.

COAXIAL VALVE | Model Series CV10

# THE PRODUCT FAMILY OF THE ROSS® COAXIAL VALVES

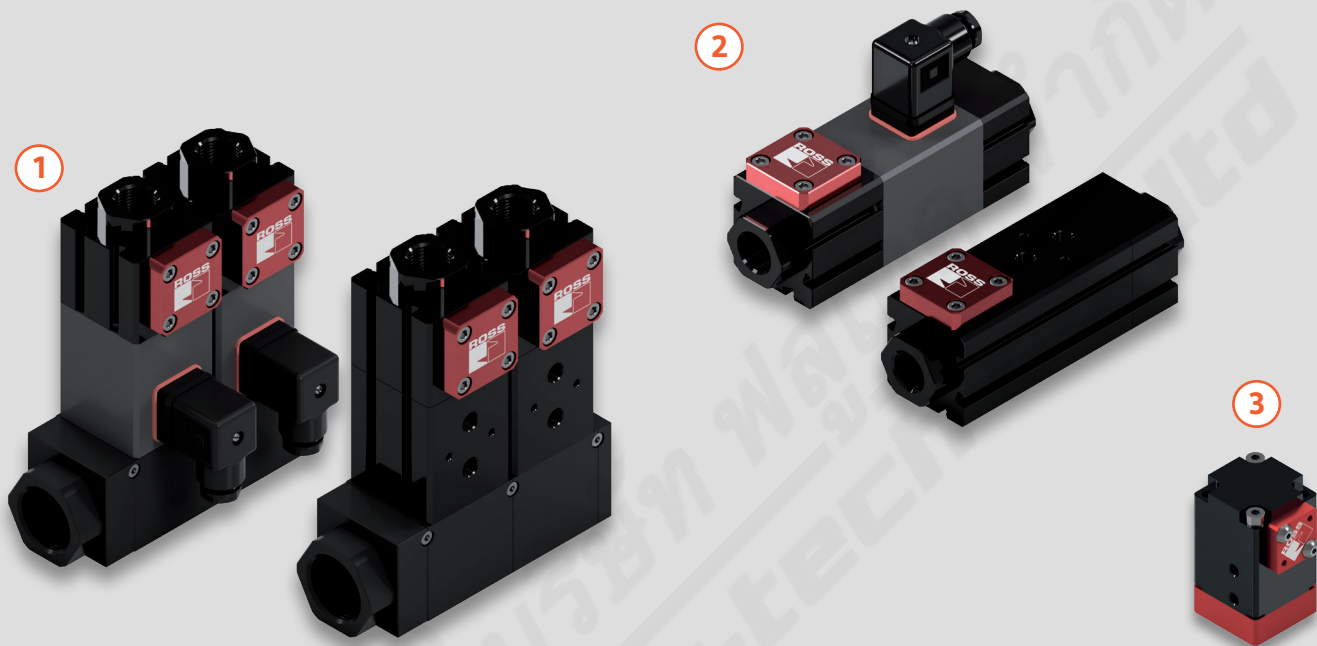

**1 COAXIAL VALVE MANIFOLD**  
(Pressure and electrically operated)

**2 COAXIAL VALVE**  
(Pressure and electrically operated)

**3 COAXIAL VALVE**  
(Special design)



**Address (HQ):** 845/3-4, Moo 3, Theparak Rd., T. Theparak, A. Mueang Samut Prakan, Samut Prakan, 10270, Thailand

**FLU-TECH CO. LTD.**

**Email:** sales@flutech.co.th **Website:** <https://flutech.co.th>

**Tel:** 02-384-6060, 086-369-5871-3 **Fax:** 02-384-5701 **LINE OA:** @flutech.co.th