



Direct-acting 3/2-way plunger valve

- Direct-acting and compact small valve up to DN 1.6
- Slipped over coil system
- Banjo fitting for direct mounting on pneumatic valves
- Simple and fast push-in, flange or manifold mounting
- Explosion-proof variants

Product variants described in the data sheet may differ from the product presentation and description.

Type description

The 7012 valve is a direct-acting plunger valve. The stopper and the core guide tube are welded together to increase pressure resistance and leak-tightness. Various housing and seal material combinations are available depending on the actual application. A Bürkert-specific flange variant (SFB) enables the space-saving arrangement of valves on a multiple manifold. The range is supplemented by explosion-proof variants. Push-in fittings can be selected for a flexible hose connection. A banjo fitting with banjo bolt is the ideal solution for easy direct mounting on a pneumatic actuator. Optional manual override enables quick start-up and optimal maintenance. In combination with a plug to industry standard shape B or DIN EN 17301-803 shape C, the valves satisfy degree of protection IP65.

FLU-TECH CO. LTD.

Email: sales@flutech.co.th **Website:** <https://flutech.co.th>

Tel: 02-384-6060, 086-369-5871-3 **Fax:** 02-384-5701 **LINE OA:** @flutech.co.th

Address (HQ): 845/3-4, Moo 3, Theparak Rd., T. Theparak, A. Mueang Samut Prakan, Samut Prakan, 10270, Thailand

LINE OA

WEBSITE



Table of contents

1. General technical data	4
1.1. Standard and banjo version.....	4
1.2. ATEX/IECEX cable version	5
2. Circuit functions	5
3. Approvals and conformities	6
3.1. General notes.....	6
3.2. Conformity	6
3.3. Standards.....	6
3.4. Explosion protection	6
3.5. North America (USA/Canada)	6
3.6. Drinking water	6
3.7. Foods and beverages/Hygiene	7
4. Materials	7
4.1. Bürkert resistApp	7
4.2. Material specifications	7
Standard version	7
ATEX/IECEX cable version	8
Banjo version	9
5. Dimensions	10
5.1. Standard version.....	10
Threaded version	10
Flange version.....	10
Flange pattern.....	11
5.2. ATEX/IECEX cable version	11
Threaded version	11
Flange version.....	12
Flange pattern.....	12
5.3. Coil versions.....	13
Versions according to industry standard form B	13
Further electrical connections.....	13
5.4. Banjo version	14
5.5. Single manifold	14
5.6. Multiple manifold.....	15
Manifolds for valves with 20 mm coil (SG2).....	15
Manifolds for valves with 24.5 mm coil (SG3).....	15
6. Device/Process connections	16
6.1. Pin assignment	16
7. Performance specifications	17
7.1. Power consumption	17
Standard version, coil size 24.5 mm	17
Standard version, coil size 20 mm.....	17
8. Ordering information	18
8.1. Bürkert eShop	18
8.2. Bürkert product filter.....	18
8.3. Bürkert Product Enquiry Form	18
8.4. Ordering chart.....	19

	Standard version according to industry standard form B, coil size 24.5 mm.....	19
	Standard version according to industry standard form B, coil size 20 mm.....	21
	Banjo version	23
	ATEX/IECEX cable version	24
	Additional options	25
8.5.	Ordering chart accessories.....	25
	Single manifold	25
	Multiple manifold.....	25
	Accessories for manifolds.....	25
	Cable plug Type 2516, form C according to DIN EN 175301 - 803.....	26
	Cable plug Type 2507, form B according to industry standard	26

DTS 1000446517 EN Version: H Status: RL (released | freigegeben | validé) printed: 08.02.2024



1. General technical data

1.1. Standard and banjo version

Product properties	
Dimensions	Further information can be found in chapter "5. Dimensions" on page 10.
Material	
Seal	FKM, EPDM
Body	Brass, polyamide (PA), stainless steel 1.4305/303
Manual override	Optional, standard for Type 7012 banjo version
Weight	
Standard version 24.5 mm solenoid coil	146 g (with G 1/8)
Standard version 20 mm solenoid coil	120 g (with G 1/8)
Banjo version	135 g
Orifice	DN 1.2...DN 2.0
Circuit function	C and D
Thermal insulation class of solenoid coil	Further information can be found in chapter "2. Circuit functions" on page 5. Epoxy coil class H
Performance data	
Nominal operating mode	
Single valve	Continuous operation 100 % ED resp. 50 % ED
For block mounting on multiple manifold	With 4 W/5 W solenoid coil 100 % ED (at max. 55 °C)
Switching time^{1.)}	
Standard version	Orifice 1.2...1.6 mm: opening 8...12 ms, closing 8...12 ms
Banjo version	Orifice 1.2 mm: opening 7...12 ms, closing 7...12 ms
Electrical data	
Operating voltage	24 DC, 24 V/50 Hz, 24 V/60 Hz, 110 V/50 Hz, 120 V/60 Hz, 230 V/50 Hz, 240 V/60 Hz
Power consumption	Further information can be found in chapter "7. Performance specifications" on page 17.
Voltage tolerance	± 10 %
Medium data	
Operating medium	Neutral gases and liquids (e.g. compressed air, water, hydraulic oil, technical vacuum)
Medium temperature	
Standard version	- 10 °C...+ 100 °C
Banjo version	- 10 °C...+ 60 °C
Viscosity	Max. 21 mm ² /s
Process/Port connection & communication	
Electrical connection	<ul style="list-style-type: none"> • Acc. to DIN EN 175301 - 803 form C for cable plug Type 2516 • Acc. to industry standard form B for cable plug Type 2507 • Flat pin terminal as protection class III device • Flying leads connection on request for coil size 20 mm
Port connection	
Standard version	M5, G 1/8, NPT 1/8, Flange
Banjo version	G 1/8, G 1/4, NPT 1/8, NPT 1/4 and hose connector Ø 6 mm
Approvals and conformities	
Degree of protection	IP65 with cable plug and ATEX/IECEx cable version
North America (USA/Canada)	Further information can be found in chapter "3.5. North America (USA/Canada)" on page 6.
Drinking water	Further information can be found in chapter "3.6. Drinking water" on page 6.
Foods and beverages/Hygiene	Further information can be found in chapter "3.7. Foods and beverages/Hygiene" on page 7.
Environment and installation	
Installation position	As required, preferably with actuator upright
Ambient temperature	
Standard version	Max. +55 °C resp. 75 °C (depending on power level)
Banjo version	- 10 °C...+ 55 °C resp. 75 °C (depending on power level)

1.) Measurement at +20 °C, 6 bar at the valve outlet acc. to DIN ISO 12238:2001, opening: pressure build-up 0...10 %, closing: pressure reduction 100...90 %

1.2. ATEX/IECEX cable version

Product properties	
Material	
Seal	FKM, EPDM
Body	Brass, stainless steel 1.4305/303
Circuit function	A and B Further information can be found in chapter "2. Circuit functions" on page 5.
Available coil size	SG3 (24.5 mm width)
Performance data	
Operating pressure	Up to 34 bar (depending on orifice and coil power)
Medium data	
Operating medium	Neutral gases and liquids (e.g. compressed air, water, hydraulic oil, technical vacuum)
Medium temperature ^{1.)}	
FKM	- 10 °C...+ 100 °C
EPDM	- 30 °C...+ 100 °C
Process/Port connection & communication	
Electrical connection	ATEX/IECEX cable version with 3 m moulded-in cable
Port connection	
Thread	G 1/8, NPT 1/8, RC1/8, M5, UNF 10-32
Flange	Flange "FK01"
Approvals and conformities	
Degree of protection	IP65 with cable plug and ATEX/IECEX cable version
Explosion protection	Further information can be found in chapter "3.4. Explosion protection" on page 6.
Environment and installation	
Ambient temperature ^{1.)}	
FKM	- 10 °C...+ 55 °C (max. + 60 °C on request)
EPDM	- 30 °C...+ 55 °C (max. + 60 °C on request)

1.) The minimum temperature depends on the seal material.

2. Circuit functions

Symbol	Description
	Circuit function C (CF C) 3/2-way solenoid valve Direct-acting Normally closed
	Circuit function D (CF D) 3/2-way solenoid valve Direct-acting Normally open

DTS 1000446517 EN Version: H Status: RL (released | valide) | freigegeben | validé) printed: 08.02.2024

3. Approvals and conformities

3.1. General notes

- The approvals and conformities listed below must be stated when making enquiries. This is the only way to ensure that the product complies with all required specifications.
- Not all available versions can be supplied with the below mentioned approvals or conformities.



3.2. Conformity

In accordance with the Declaration of Conformity, the product is compliant with the EU Directives.

3.3. Standards

The applied standards which are used to demonstrate compliance with the EU Directives are listed in the EU-Type Examination Certificate and/or the EU Declaration of Conformity.

3.4. Explosion protection

Approval	Description
 	<p>Optional: Explosion protection (valid for coils with fixed cable outlet)</p> <p>ATEX: EPS 21 ATEX 1 128 X II 2G Ex mb IIC T4 Gb II 2D Ex mb IIIC T130 °C Db</p> <p>IECEX: IECEX EPS 21.0045X Ex mb IIC T4 Gb Ex mb IIIC T130 °C Db</p> <p>Fixed cable is halogen-free according to IEC 60754 - 1</p>

3.5. North America (USA/Canada)

Approval	Description
	<p>Valid for coils:: UL Recognized for the USA and Canada</p> <p>The coils are UL Recognized for the USA and Canada according to:</p> <ul style="list-style-type: none"> • UL 429 (electrically operated valves) • CAN/CSA-C22.2 No. 139

3.6. Drinking water

Conformity	Description
	<p>Suitable for use in drinking water applications</p> <p>The materials comply with the assessment principles (UBA) for materials in contact with drinking water (TrinkwasserV).</p> <p>PA body: PF36: Suitable for products with a maximum temperature of 60 °C (warm water)</p> <p>PPS/brass/stainless steel body: PF39: Suitable for products with a maximum temperature of 85 °C (hot water)</p>

DTS 1000446517 EN Version: H Status: RL (released | freigegeben | validé) printed: 08.02.2024

3.7. Foods and beverages/Hygiene

Conformity	Description
FDA	FDA – Code of Federal Regulations (valid for the variable code PL02, PL03) All wetted materials are compliant with the Code of Federal Regulations published by the FDA (Food and Drug Administration, USA) according to the manufacturer’s declaration.
USP	United States Pharmacopeial Convention (USP) (valid for the variable code PL04) All wetted materials are biocompatible according to the manufacturer’s declaration.
	EC Regulation 1935/2004 of the European Parliament and of the Council (valid for the variable code PL01, PL02) All wetted materials are compliant with EC Regulation 1935/2004/EC according to the manufacturer’s declaration.

4. Materials

4.1. Bürkert resistApp

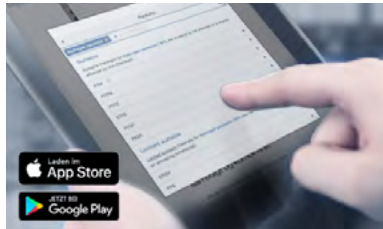

Bürkert resistApp – Chemical resistance chart

You want to ensure the reliability and durability of the materials in your individual application case? Verify your combination of media and materials on our website or in our resistApp.

[Start chemical resistance check](#)

4.2. Material specifications

Standard version

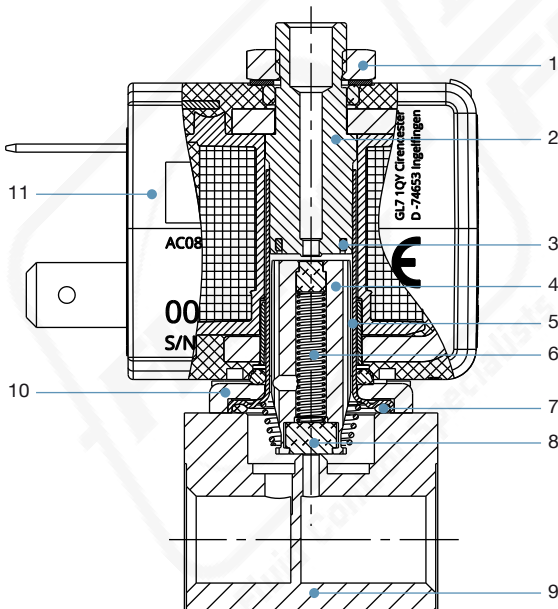

No.	Element	Material
1	Locknut	DIN 176 Surface finish thick film passivated KOSA0101
2	Stopper	Stainless steel 1.4113/434
3	Shading ring	Copper (silver optional)
4	Core	Stainless steel 1.4113/434
5	Core guide tube	Stainless steel 1.4303/305L
6	Spring	Stainless steel 1.4310/301
7	O-ring	FKM/EPDM
8	Seal	FKM/EPDM
9	Valve body	Brass, stainless steel 1.4305/303 PA (polyamide)
10	Flange	<ul style="list-style-type: none"> Surface finish thick film passivated KOSA0101 (brass version) Nickel-plated surface (stainless steel version)
11	Coil	Epoxy

ATEX/IECEX cable version

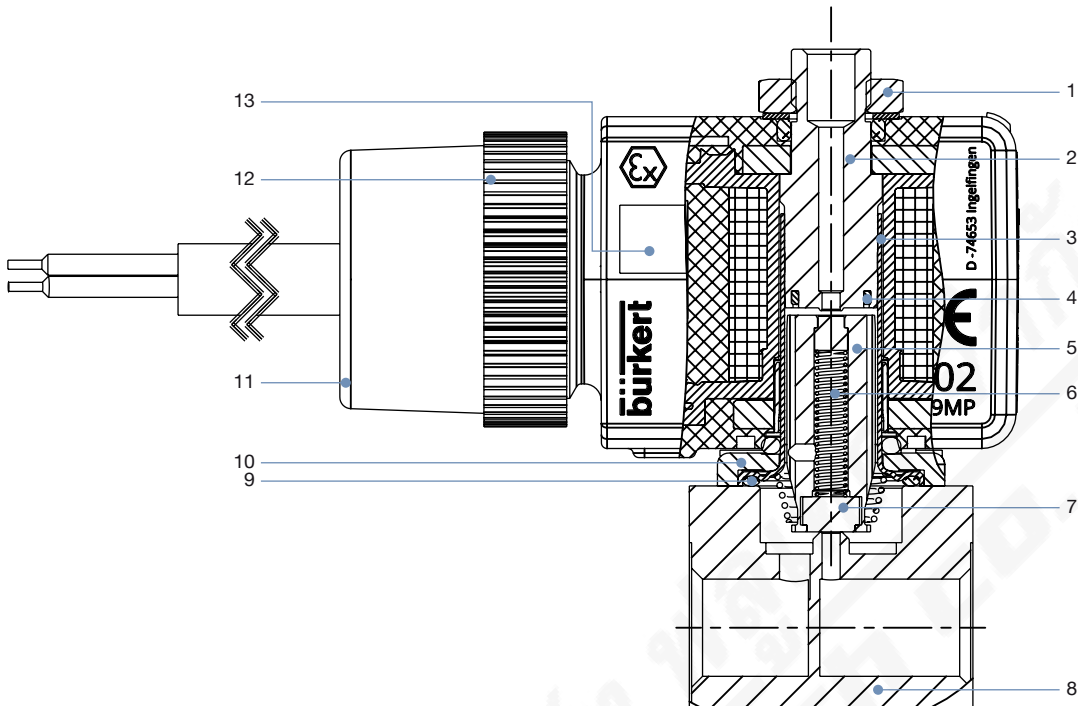

No.	Element	Material
1	Locknut	DIN 176 Surface finish thick film passivated KOSA0101
2	Stopper	Stainless steel 1.4113/434
3	Core guide tube	Stainless steel 1.4303 ST/305L
4	Shading ring	Copper (optional silver)
5	Core	Stainless steel 1.4113/434
6	Spring	Stainless steel 1.4310/301
7	Seal	FKM/EPDM
8	Valve body	Brass, stainless steel 1.4305/303 PA (polyamide)
9	O-Ring	FKM/EPDM
10	Flange	<ul style="list-style-type: none"> • Surface finish thick film passivated KOSA0101 (brass version) • Nickel-plated surface (stainless steel version)
11	Sealing ring	Silicone
12	Union nut	PA (Polyamide)
13	Coil	Epoxy

DTS 1000446517 EN Version: H Status: RL (released | freigegeben | validé) printed: 08.02.2024

Banjo version

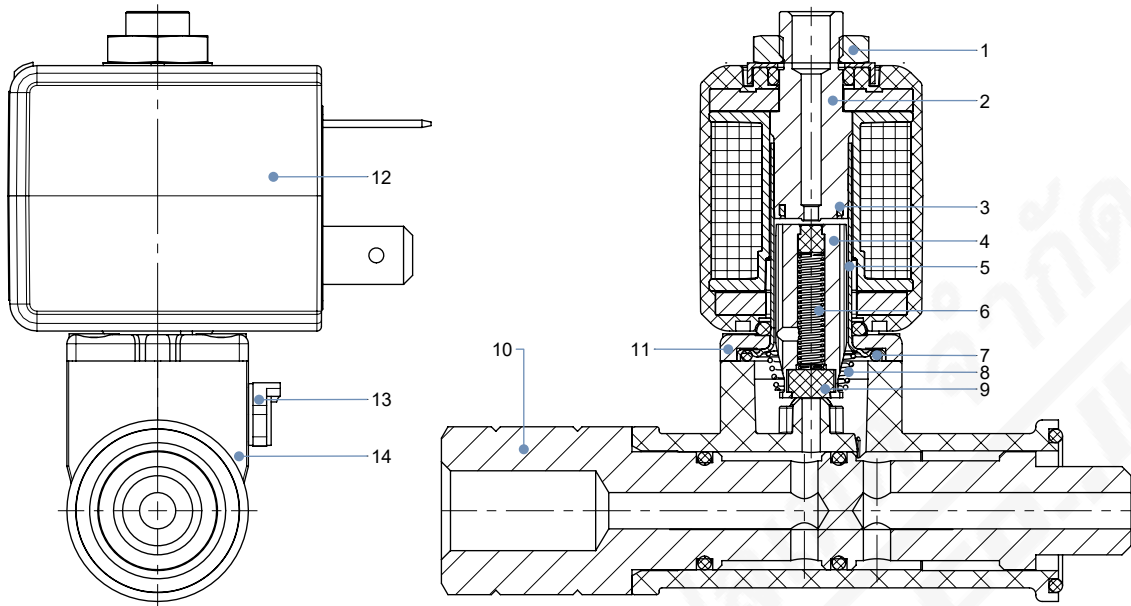

No.	Element	Material
1	Locknut	DIN 176 Surface finish thick film passivated KOSA0101
2	Stopper	Stainless steel 1.4113
3	Shading ring	Copper (silver optional)
4	Core	Stainless steel 1.4113
5	Core guide tube	Stainless steel 1.4303 ST
6	Spring	Stainless steel 1.4310
7	O-ring	FKM
8	Spring	Stainless steel 1.4310
9	Seal	FKM
10	Banjo bolt	Nickel-plated brass
11	Flange	<ul style="list-style-type: none"> • Surface finish thick film passivated KOSA0101 (brass version) • Nickel-plated surface (stainless steel version)
12	Coil	Epoxy
13	Manual override	Durethan
14	Body	PPS (polyphenylene sulphide)

DTS 1000446517 EN Version: H Status: RL (released | freigeben | validé) printed: 08.02.2024

5. Dimensions

5.1. Standard version

Threaded version

Note:

- Dimensions in mm
- Versions according to industry standard form B

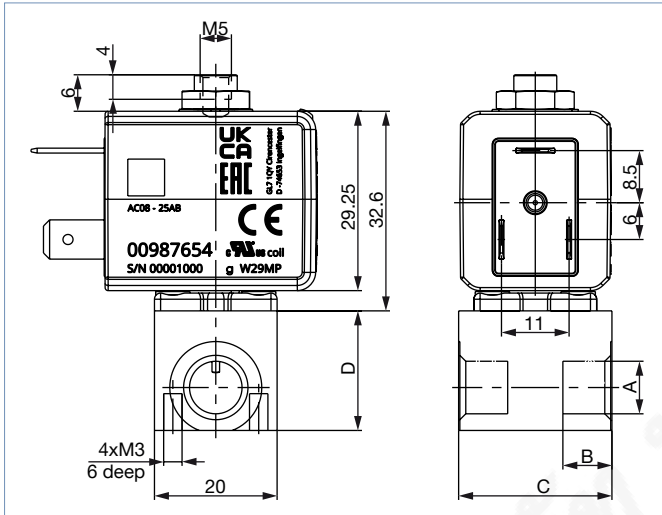

Port connection	A	B [mm]	C [mm]	D [mm]
Thread	M5	5	20	14
	G 1/8	8	25	19.5
	NPT 1/8	7	25	19.5

Flange version

Note:

- Dimensions in mm
- Versions according to industry standard form B

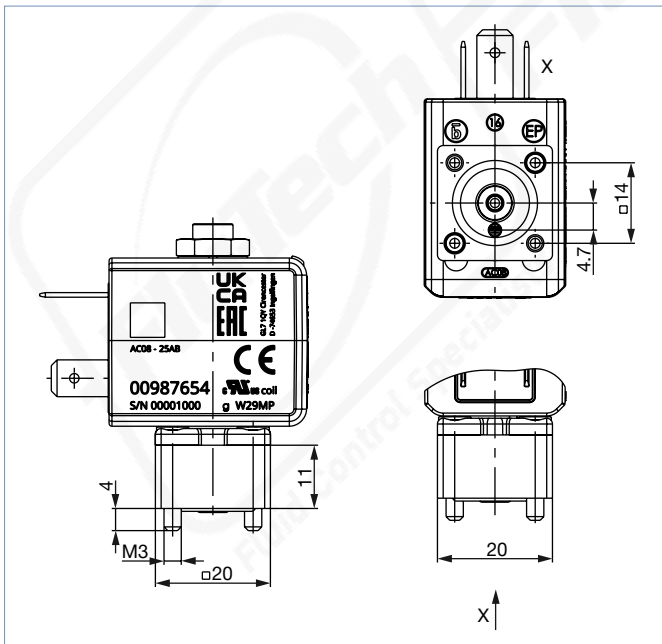

DTS 1000446517 EN Version: H Status: RL (released | freigeben | validé) printed: 08.02.2024

Flange pattern

Note:

- Dimensions in mm
- On the connection side, the geometries are to be realised as shown in the following drawing.
- Flange version (FK01) according to FST 1000225877

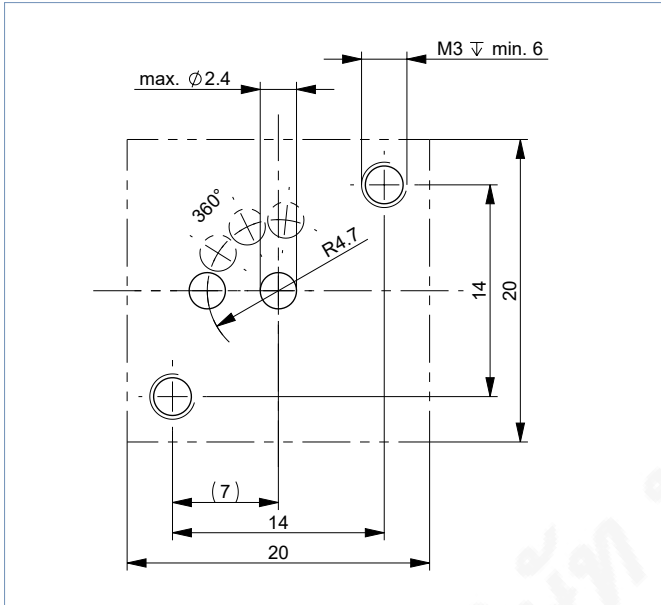

5.2. ATEX/IECEx cable version

Threaded version

Note:

Dimensions in mm

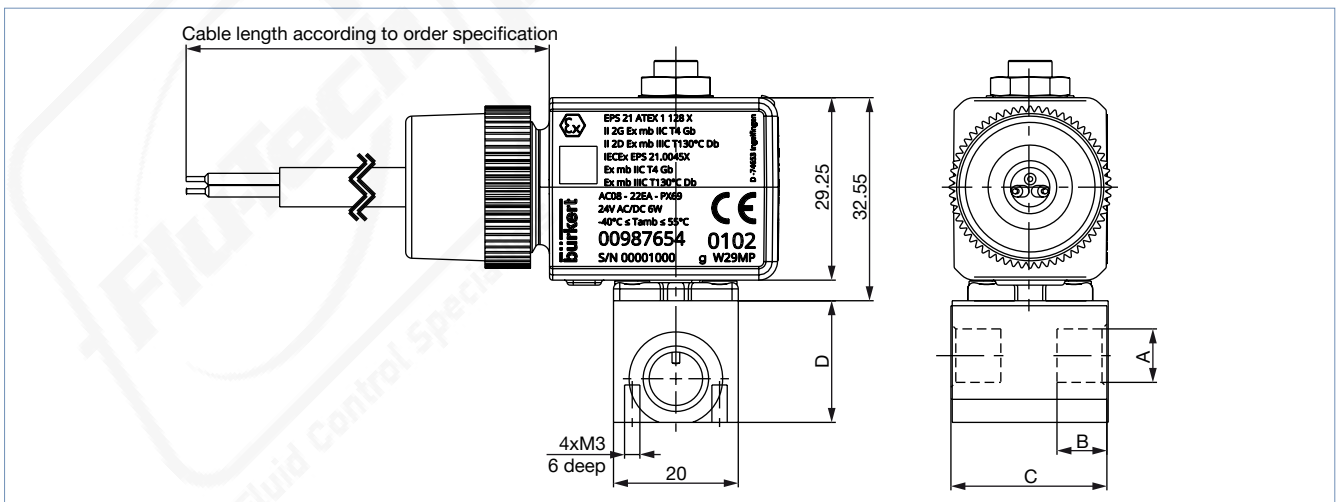

Port connection	A	B	C	D
		[mm]	[mm]	[mm]
Thread	M5	5	20	14
Thread	G 1/8	8	25	19.5

Flange version

Note:

Dimensions in mm

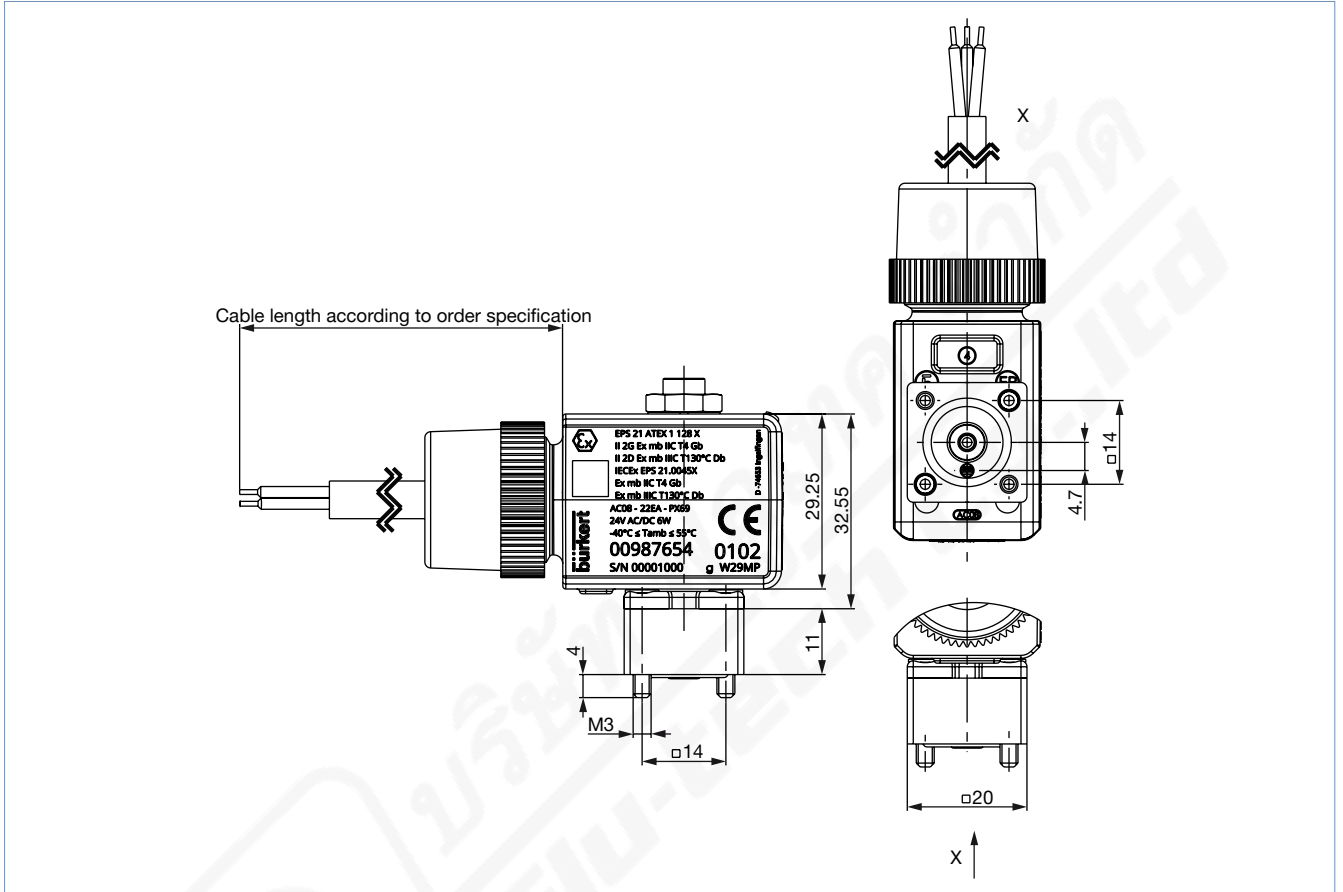

Flange pattern

Note:

- Dimensions in mm
- On the connection side, the geometries are to be realised as shown in the following drawing.
- Flange version (FK01) according to FST 1000225877

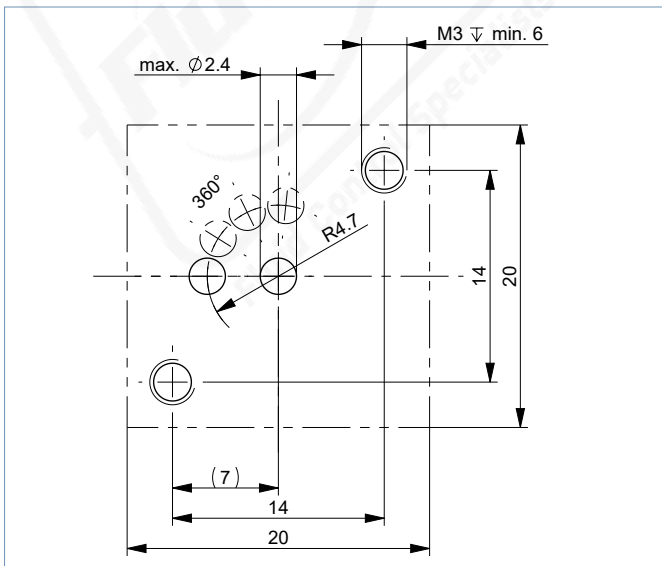

5.3. Coil versions

Versions according to industry standard form B

Note:

Dimensions in mm

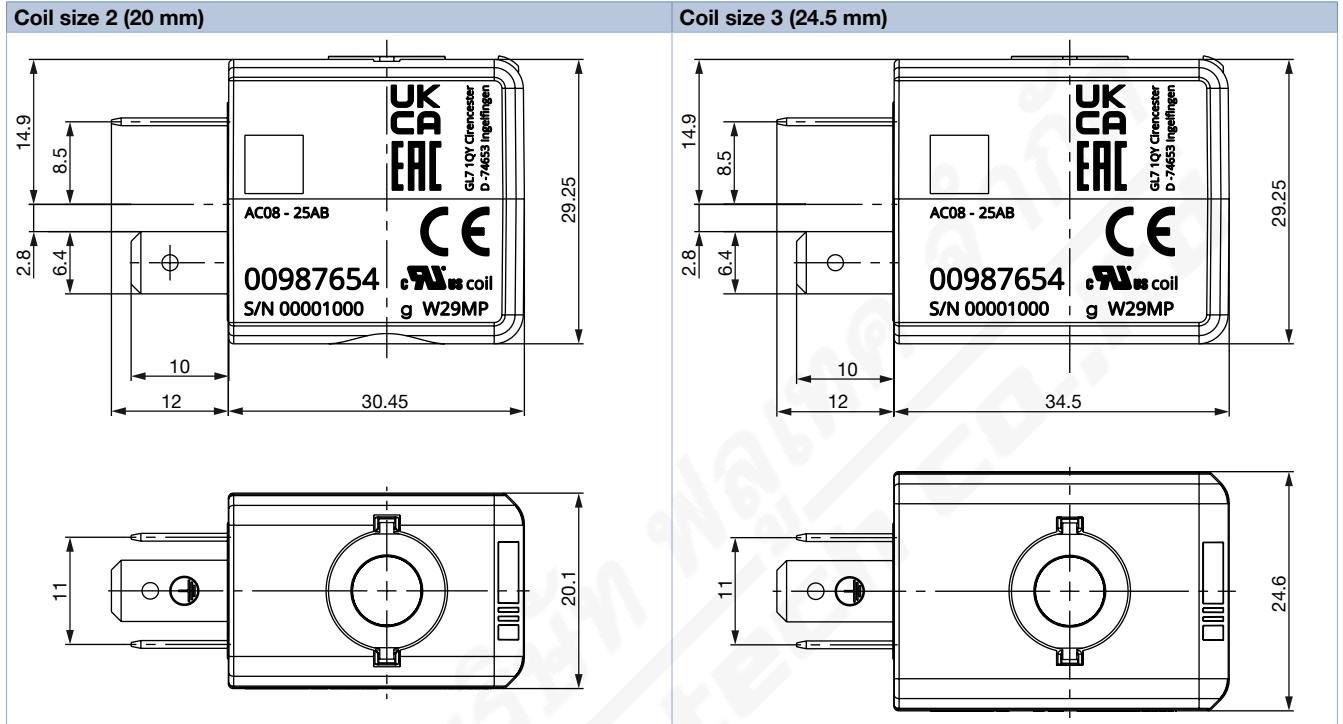

Further electrical connections

Note:

- Dimensions in mm
- Specifications apply to coil sizes 20 mm and 24.5 mm

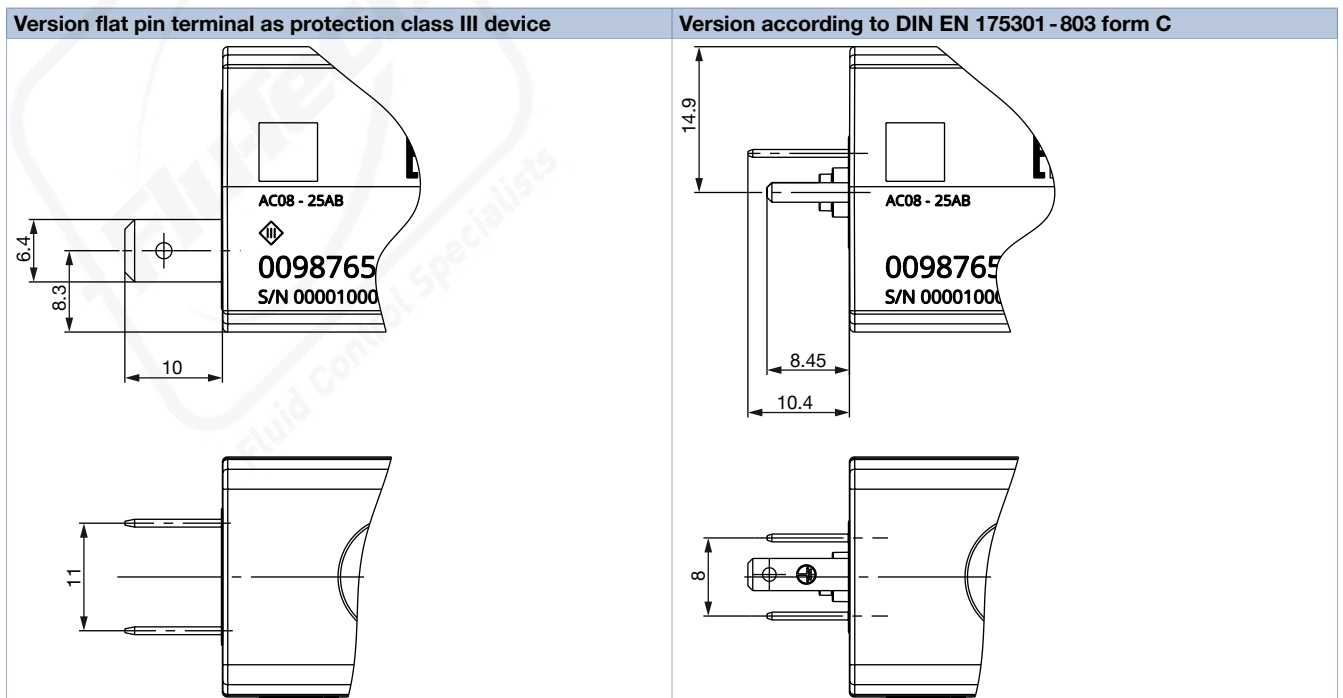

DTS 1000446517 EN Version: H Status: RL (released | freigegeben | validé) printed: 08.02.2024

5.4. Banjo version

Note:

- Dimensions in mm
- Coil size 24.5 mm
- Plug connection for compressed air: Pressure port P can be continuously rotated through 360°.
- Available orifices: 1.6 mm and 2.0 mm

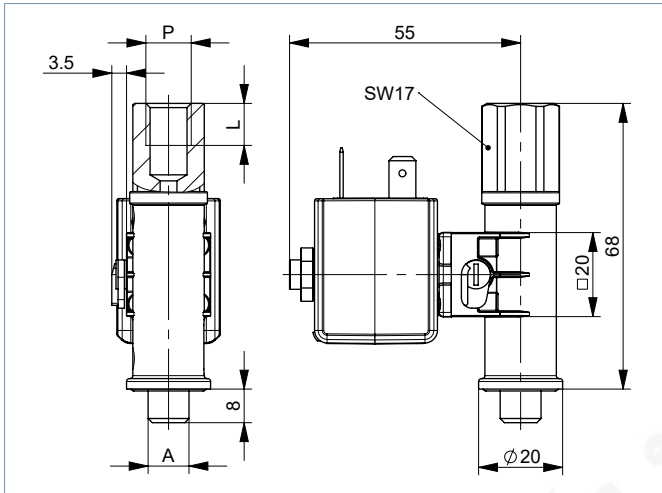

Version	P [Zoll]	A [Zoll]	L [mm]
BJ01	G 1/8	G 1/8	8
BJ02	G 1/4	G 1/4	12
BJ03	NPT 1/4	G 1/8	12.9
BJ04	NPT 1/4	G 1/4	12.9
BJ05	G 1/4	G 1/8	12
BJ06	G 1/8	G 1/4	8
BJ07	NPT 1/8	G 1/8	8.9

5.5. Single manifold

Note:

- Dimensions in mm
- Can only be combined with valves with coil size 20 mm
- Manifolds with valves of coil size 24.5 mm on request

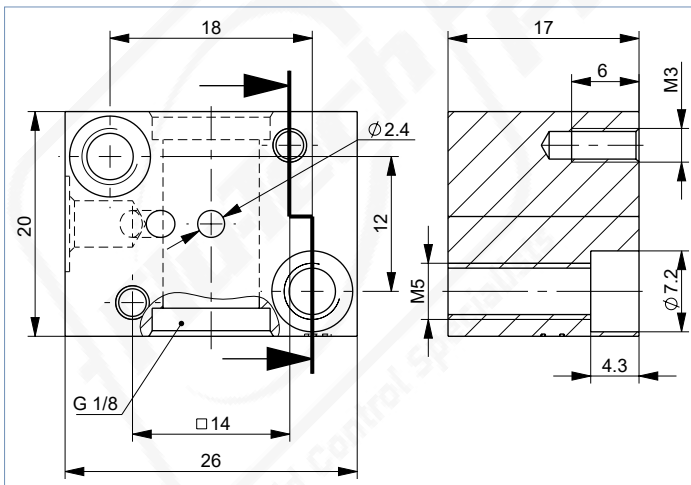

Quantity of valve places	A [mm]	B [mm]	C [mm]	Article no.
1	20	12	-	005312

DTS 1000446517 EN Version: H Status: RL (released | freigegeben | validé) printed: 08.02.2024

5.6. Multiple manifold

Manifolds for valves with 20 mm coil (SG2)

Note:

- Dimensions in mm
- Can only be combined with Type 7012 valves with coil size 20 mm

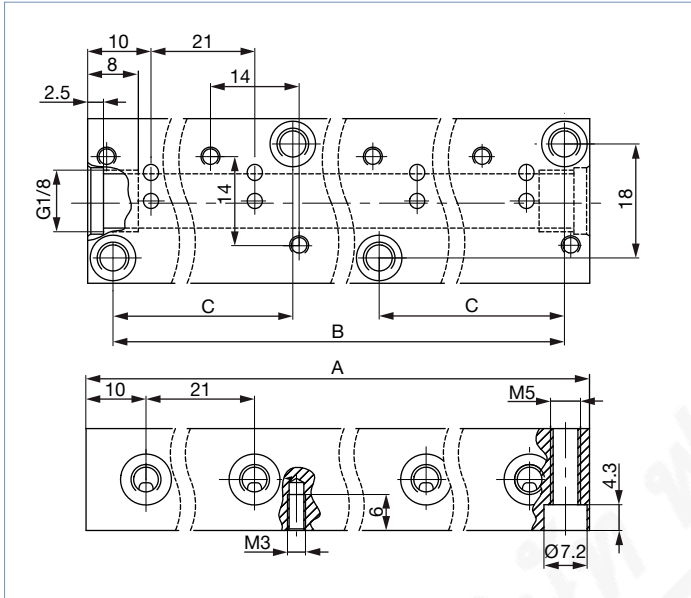

Quantity of valve places	A [mm]	B [mm]	C [mm]	Article no.
2	41	33	-	005355
3	62	54	-	005313
4	83	75	-	005314
5	104	96	-	005315
6	125	117	-	005316
7	146	138	-	005893
8	167	159	54	005166
9	188	180	54	005241
10	209	201	75	005819
11	230	222	75	005242
12	251	243	96	005222

Manifolds for valves with 24.5 mm coil (SG3)

Note:

- Dimensions in mm
- Can only be combined with Type 7012 valves with coil size 24.5 mm

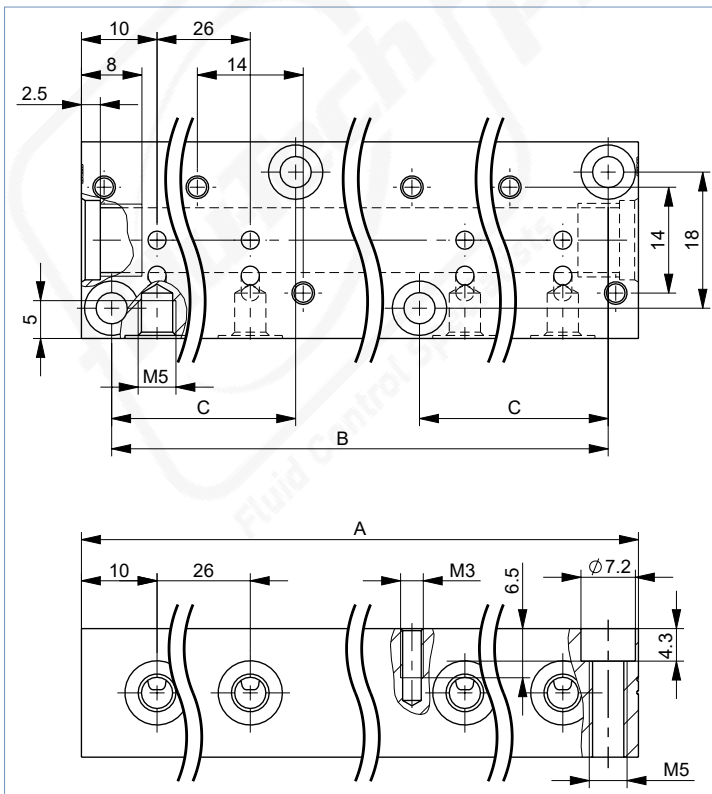

Quantity of valve places	A [mm]	B [mm]	C [mm]	Article no.
2	46	38	-	60021427
3	72	64	-	60021342
4	98	90	-	60021429
5	124	116	-	60021428
6	150	142	-	60021442
7	176	168	-	20060327
8	202	194	64	20060338
9	228	220	64	20060341
10	254	246	90	20015744
11	280	272	90	20060374
12	306	298	116	20060376

DTS 1000446517 EN Version: H Status: RL (released | freigegeben | validé) printed: 08.02.2024

6. Device/Process connections

6.1. Pin assignment

For the positions marked with *, ** or *** in the drawing, the connections are marked with the letters shown in the table above, depending on the circuit function. Unused connections in circuit functions A or B will be closed off with a blanking plug or cap nut.

Circuit function	Connection Type			Threaded version	Flange version
	*	**	***		
A	P	to lock	A		
B	to lock	B	P		
C	P	R	A		
D	R	P	B		
T	P	R	A		



7. Performance specifications

7.1. Power consumption

Standard version, coil size 24.5 mm

Coil	Orifice [mm]	Electrical power					Switching times ^{1.)}	
		Inrush AC [VA]	Hold AC		DC		Opening [ms]	Closing [ms]
			[VA]	[W]	Cold [W]	Hot [W]		
24 V/DC/7 W	1.2	–	–	–	7	5.5	8...12	8...12
	1.6							
	2.0							
24 V/DC/5.5 W	1.2	–	–	–	5.5	4.5		
	1.6							
	2.0							
24 V/50 Hz/4 W	1.2	12	6.5	4	–	–		
	1.6							
	2.0							
230 V/50 Hz/4 W	1.2	12	6.5	4	–	–		
	1.6							
	2.0							

1.) Measurement at +20 °C, 6 bar^{2.)} at the valve outlet acc. to DIN ISO 12238:2001, opening: pressure build-up 0...10%, closing: pressure reduction 100...90%
 2.) Pressure data: overpressure to atmospheric pressure and air as a medium

Standard version, coil size 20 mm

Coil	Orifice [mm]	Electrical power					Switching times ^{1.)}	
		Inrush AC [VA]	Hold AC		DC		Opening [ms]	Closing [ms]
			[VA]	[W]	Cold [W]	Hot [W]		
24 V/DC/6.5 W	1.2	–	–	–	6.5	5	8...12	8...12
	1.6							
	2.0							
24 V/50 Hz/6 W	1.2	11	7	6	–	–		
	1.6							
	2.0							
230 V/50 Hz/6 W	1.2	11	7	6	–	–		
	1.6							
	2.0							
24 V/DC/5 W	1.2	–	–	–	5	4		
	1.6							
	2.0							
24 V/50 Hz/4 W	1.2	9	5	4	–	–		
	1.6							
	2.0							
230 V/50 Hz/4 W	1.2	9	5	4	–	–		
	1.6							
	2.0							

1.) Measurement at +20 °C, 6 bar^{2.)} at the valve outlet acc. to DIN ISO 12238:2001, opening: pressure build-up 0...10%, closing: pressure reduction 100...90%
 2.) Pressure data: overpressure to atmospheric pressure and air as a medium

DTS 1000446517 EN Version: H Status: RL (released | freigegeben | validé) printed: 08.02.2024

8. Ordering information

8.1. Bürkert eShop



Bürkert eShop – Easy ordering and quick delivery

You want to find your desired Bürkert product or spare part quickly and order directly? Our online shop is available for you 24/7. Sign up and enjoy all the benefits.

[Order online now](#)

8.2. Bürkert product filter



Bürkert product filter – Get quickly to the right product

You want to select products comfortably based on your technical requirements? Use the Bürkert product filter and find suitable articles for your application quickly and easily.

[Try out our product filter](#)

8.3. Bürkert Product Enquiry Form

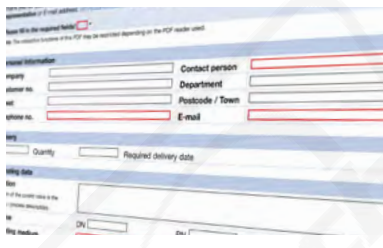

Bürkert Product Enquiry Form – Your enquiry quickly and compactly

Would you like to make a specific product enquiry based on your technical requirements? Use our Product Enquiry Form for this purpose. There you will find all the relevant information for your Bürkert contact. This will enable us to provide you with the best possible advice.

[Fill out the form now](#)

DTS 1000446517 EN Version: H Status: RL (released | freigegeben | validé) printed: 08.02.2024

8.4. Ordering chart

Standard version according to industry standard form B, coil size 24.5 mm

Note:

All valves are delivered without a cable plug.

Circuit function	Port connection	Orifice [mm]	K _v value water ¹⁾ [m ³ /h]	Voltage/ Frequency/ Power [V/Hz/W]	Maximum duty cycle	Pressure range ²⁾³⁾		Article no.		
						Ambient temperature 75 °C Air + water [bar]	Ambient temperature 55 °C Air + water [bar]	Brass body	Stainless steel body	
								FKM seal		
CF C 3/2-way solenoid valve Direct-acting Normally closed 	M5	1.2	0.045	24/DC/7	100 % ED	–	0...13	380922	381000	
				24/DC/5.5		0...11.5	390256	390258		
				24/50/4		0...13	380924	381002		
				230/50/4		0...13	380927	381004		
		1.6	0.060	24/DC/7	100 % ED	–	0...7.5	380932	381021	
				24/DC/5.5		0...6	390265	390267		
				24/50/4		0...7.5	380931	381023		
				230/50/4		0...7.5	380928	381025		
		2.0 ⁴⁾	0.110	24/DC/7	100 % ED	–	0...7	o. r.	o. r.	
				24/DC/5.5		0...5	o. r.	o. r.		
				24/50/4		0...6	o. r.	o. r.		
				230/50/4		0...6	o. r.	o. r.		
	G 1/8	1.2	0.045	0.045	24/DC/7	100 % ED	–	0...13	379906	380132
					24/DC/5.5		0...11.5	390269	390271	
					24/50/4		0...13	379928	380139	
					230/50/4		0...13	380116	380217	
		1.6	0.060	0.060	24/DC/7	100 % ED	–	0...7.5	379915	380137
					24/DC/5.5		0...6	390275	390273	
					24/50/4		0...7.5	379930	380141	
					230/50/4		0...7.5	380118	380218	
		2.0 ⁴⁾	0.110	0.110	24/DC/7	100 % ED	–	0...7	o. r.	o. r.
					24/DC/5.5		0...5	o. r.	o. r.	
					24/50/4		0...6	o. r.	o. r.	
					230/50/4		0...6	o. r.	o. r.	
Flange (FK01)	1.2	0.045	0.045	24/DC/7	100 % ED	–	0...13	380943	390301	
				24/DC/5.5		0...11.5	390348	390351		
				24/50/4		0...13	380942	381029		
				230/50/4		0...13	380940	390353		
	1.6	0.060	0.060	24/DC/7	100 % ED	–	0...7.5	380934	390355	
				24/DC/5.5		0...6	390358	390360		
				24/50/4		0...7.5	380936	390362		
				230/50/4		0...7.5	380938	389484		
	2.0 ⁴⁾	0.110	0.110	24/DC/7	100 % ED	–	0...7	o. r.	o. r.	
				24/DC/5.5		0...5	o. r.	o. r.		
				24/50/4		0...6	o. r.	o. r.		
				230/50/4		0...6	o. r.	o. r.		

DTS 1000446517 EN Version: H Status: RL (released | freigegeben | valide) printed: 08.02.2024

Circuit function	Port connection	Orifice	K _v value water ¹⁾	Voltage/Frequency/Power	Maximum duty cycle	Pressure range ²⁾³⁾		Article no.	
						Ambient temperature 75 °C	Ambient temperature 55 °C	Brass body	Stainless steel body
		[mm]	[m ³ /h]	[V/Hz/W]	Air + water [bar]	Air + water [bar]	FKM seal		
CF D 3/2-way solenoid valve Direct-acting Normally open 	M5	1.2	0.045	24/DC/5.5	100 % ED	0...10	0...10	390363	390365
				24/50/4		0...10	0...10	390367	390382
				230/50/4		0...10	0...10	390385	390384
		1.6	0.060	24/DC/5.5	100 % ED	0...6	0...6	390390	390392
				24/50/4		0...6	0...6	390396	390398
				230/50/4		0...6	0...6	390400	390401
		2.0 ⁴⁾	0.110	24/DC/5.5	100 % ED	0...8	0...8	o. r.	o. r.
				24/50/4		0...7	0...7	o. r. ⁵⁾	o. r. ⁵⁾
				230/50/4		0...7	0...7	o. r. ⁵⁾	o. r. ⁵⁾
	G 1/8	1.2	0.045	24/DC/5.5	100 % ED	0...10	0...10	385475	390402
				24/50/4		0...10	0...10	390406	390409
				230/50/4		0...10	0...10	390438	390439
		1.6	0.060	24/DC/5.5	100 % ED	0...6	0...6	390440	390442
				24/50/4		0...6	0...6	390444	390446
				230/50/4		0...6	0...6	390448	390449
		2.0 ⁴⁾	0.110	24/DC/5.5	100 % ED	0...8	0...8	o. r.	o. r.
				24/50/4		0...7	0...7	o. r. ⁵⁾	o. r. ⁵⁾
				230/50/4		0...7	0...7	o. r. ⁵⁾	o. r. ⁵⁾
	Flange (FK01)	1.2	0.045	24/DC/5.5	100 % ED	0...10	0...10	390450	390452
				24/50/4		0...10	0...10	390456	393085
				230/50/4		0...10	0...10	390459	390460
		1.6	0.060	24/DC/5.5	100 % ED	0...6	0...6	390462	390464
				24/50/4		0...6	0...6	390468	390466
				230/50/4		0...6	0...6	390470	390471
2.0 ⁴⁾		0.110	24/DC/5.5	100 % ED	0...8	0...8	o. r.	o. r.	
			24/50/4		0...7	0...7	o. r. ⁵⁾	o. r. ⁵⁾	
			230/50/4		0...7	0...7	o. r. ⁵⁾	o. r. ⁵⁾	

o. r.: on request

- 1.) Measurement at +20 °C, 1 bar²⁾ at the valve inlet and free outlet
- 2.) Pressure data: overpressure to atmospheric pressure and air as a medium
- 3.) Number of switching cycles under laboratory conditions (FKM seal, oiled air, unpressurised, DC): 5 million. Please note that an increase in switching pressure can limit the life of the seat seal.
- 4.) Limited swelling compensation
- 5.) Can also be feasible with coil size 2

DTS 1000446517 EN Version: H Status: RL (released | freigegeben | validé) printed: 08.02.2024

Standard version according to industry standard form B, coil size 20 mm

Note:

All valves are delivered without a cable plug.

Circuit function	Port connection	Orifice	K _v value water ¹⁾	Voltage/ Frequency/ Power	Maximum duty cycle	Pressure range ²⁾³⁾		Article no.	
						Ambient temperature 75 °C	Ambient temperature 55 °C	Brass body	Stainless steel body
		[mm]	[m ³ /h]	[V/Hz/W]	Air + water [bar]	Air + water [bar]	FKM seal		
CF C 3/2-way solenoid valve Direct-acting Normally closed 	M5	1.2	0.045	24/DC/6.5	100 % ED	–	0...11	o. r.	o. r.
				24/50/6		–	0...13	o. r.	o. r.
				230/50/6		–	0...13	o. r.	o. r.
				24/DC/5		0...10	0...10	o. r.	o. r.
				24/50/4		0...11	0...11	o. r.	o. r.
				230/50/4		0...11	0...11	o. r.	o. r.
		1.6	0.060	24/DC/6.5	100 % ED	–	0..6	o. r.	o. r.
				24/50/6		–	0...7.5	o. r.	o. r.
				230/50/6		–	0...7.5	o. r.	o. r.
				24/DC/5		0...5.5	0...5.5	o. r.	o. r.
				24/50/4		0...6	0...6	o. r.	o. r.
				230/50/4		0...6	0...6	o. r.	o. r.
	2.0 ⁴⁾	0.110	24/DC/6.5	100 % ED	–	0..5	o. r.	o. r.	
			24/50/6		–	0..6	o. r.	o. r.	
			230/50/6		–	0..6	o. r.	o. r.	
			24/DC/5		0..4	0..4	o. r.	o. r.	
			24/50/4		0...5.5	0...5.5	o. r.	o. r.	
			230/50/4		0...5.5	0...5.5	o. r.	o. r.	
	G ½	1.2	0.045	100 % ED	24/DC/6.5	–	0...11	o. r.	o. r.
					24/50/6	–	0...13	o. r.	o. r.
					230/50/6	–	0...13	o. r.	o. r.
					24/DC/5	0...10	0...10	o. r.	o. r.
					24/50/4	0...11	0...11	o. r.	o. r.
					230/50/4	0...11	0...11	o. r.	o. r.
1.6		0.060	100 % ED	24/DC/6.5	–	0..6	o. r.	o. r.	
				24/50/6	–	0...7.5	o. r.	o. r.	
				230/50/6	–	0...7.5	o. r.	o. r.	
				24/DC/5	0...5.5	0...5.5	o. r.	o. r.	
				24/50/4	0...6	0...6	o. r.	o. r.	
				230/50/4	0...6	0...6	o. r.	o. r.	
2.0 ⁴⁾	0.110	100 % ED	24/DC/6.5	–	0..5	o. r.	o. r.		
			24/50/6	–	0..6	o. r.	o. r.		
			230/50/6	–	0..6	o. r.	o. r.		
			24/DC/5	0..4	0..4	o. r.	o. r.		
			24/50/4	0...5.5	0...5.5	o. r.	o. r.		
			230/50/4	0...5.5	0...5.5	o. r.	o. r.		
Flange (FK01)	1.2	0.045	100 % ED	24/DC/6.5	–	0...11	o. r.	o. r.	
				24/50/6	–	0...13	o. r.	o. r.	
				230/50/6	–	0...13	o. r.	o. r.	
				24/DC/5	0...10	0...10	o. r.	o. r.	
				24/50/4	0...11	0...11	o. r.	o. r.	
				230/50/4	0...11	0...11	o. r.	o. r.	

DTS 1000446517 EN Version: H Status: RL (released | freigegeben | validé) printed: 08.02.2024

Circuit function	Port connection	Orifice	K _v value water ^{1.)}	Voltage/Frequency/Power	Maximum duty cycle	Pressure range ²⁾³⁾		Article no.						
						Ambient temperature 75 °C Air + water	Ambient temperature 55 °C Air + water	Brass body	Stainless steel body					
		[mm]	[m ³ /h]	[V/Hz/W]	[bar]	[bar]	FKM seal							
CF C 3/2-way solenoid valve Direct-acting Normally closed 	Flange (FK01)	1.6	0.060	24/DC/6.5	100 % ED	–	0...6	o. r.	o. r.					
				24/50/6		–	0...7.5	o. r.	o. r.					
				230/50/6		–	0...7.5	o. r.	o. r.					
				24/DC/5		0...5.5	0...5.5	o. r.	o. r.					
				24/50/4		0...6	0...6	o. r.	o. r.					
				230/50/4		0...6	0...6	o. r.	o. r.					
		2.0 ⁴⁾	0.110	24/DC/6.5	100 % ED	–	0...5	o. r.	o. r.					
				24/50/6		–	0...6	o. r.	o. r.					
				230/50/6		–	0...6	o. r.	o. r.					
				24/DC/5		0...4	0...4	o. r.	o. r.					
				24/50/4		0...5.5	0...5.5	o. r.	o. r.					
				230/50/4		0...5.5	0...5.5	o. r.	o. r.					
				CF D		M5	1.2	0.045	24/DC/5	100 % ED	0...10	0...10	o. r.	o. r.
									24/50/4		0...10	0...10	o. r.	o. r.
230/50/4	0...10	0...10	o. r.	o. r.										
		1.6	0.060	24/DC/5	100 % ED	0...6	0...6	o. r.	o. r.					
				24/50/4		0...6	0...6	o. r.	o. r.					
				230/50/4		0...6	0...6	o. r.	o. r.					
		2.0 ⁴⁾	0.110	24/DC/6.5	100 % ED	–	0...8	o. r.	o. r.					
				24/DC/5		0...6	0...6	o. r.	o. r.					
				24/50/4		0...7	0...7	o. r.	o. r.					
				G 1/8	0.045	24/DC/5	100 % ED	0...10	0...10	o. r.	o. r.			
						24/50/4		0...10	0...10	o. r.	o. r.			
						230/50/4		0...10	0...10	o. r.	o. r.			
				1.6	0.060	24/DC/5	100 % ED	0...6	0...6	o. r.	o. r.			
						24/50/4		0...6	0...6	o. r.	o. r.			
						230/50/4		0...6	0...6	o. r.	o. r.			
2.0 ⁴⁾	0.110			24/DC/6.5	100 % ED	–	0...8	o. r.	o. r.					
				24/DC/5		0...6	0...6	o. r.	o. r.					
				24/50/4		0...7	0...7	o. r.	o. r.					
				Flange (FK01)	0.045	24/DC/5	100 % ED	0...10	0...10	o. r.	o. r.			
						24/DC/5.5		0...6	0...6	o. r.	o. r.			
						24/50/4		0...10	0...10	o. r.	o. r.			
		1.6	0.060	24/DC/5	100 % ED	0...6	0...6	o. r.	o. r.					
				24/50/4		0...6	0...6	o. r.	o. r.					
				230/50/4		0...6	0...6	o. r.	o. r.					
		2.0 ⁴⁾	0.110	24/DC/6.5	100 % ED	–	0...8	o. r.	o. r.					
				24/DC/5		0...6	0...6	o. r.	o. r.					
				24/50/4		0...7	0...7	o. r.	o. r.					
				230/50/4		0...7	0...7	o. r.	o. r.					

o. r.: on request

1.) Measurement at +20 °C, 1 bar²⁾ at the valve inlet and free outlet

2.) Pressure data: overpressure to atmospheric pressure and air as a medium

3.) Number of switching cycles under laboratory conditions (FKM seal, oiled air, unpressurised, DC): 5 million. Please note that an increase in switching pressure can limit the life of the seat seal.

4.) Limited swelling compensation

DTS 1000446517 EN Version: H Status: RL (released | freigeben | validé) printed: 08.02.2024

Banjo version

Note:

- All valves are delivered without a cable plug.
- Coil size 24,5 mm
- Orifices 1.6 mm and 2.0 mm on request.

Circuit function	Port connection	Orifice	Q _{Nn} value air	Voltage/Frequency/ Power	Maximum duty cycle	Medium pressure ¹⁾²⁾ Ambient temperature max. +55 °C resp. +75 °C ³⁾	Article no.	
		[mm]	[l/min]	[V/Hz/W]		Air [bar]	FKM seal	
CF C 3/2-way solenoid valve Direct-acting Normally closed 	BJ01 P: G 1/8 A: G 1/8	1.2	35	24/DC/7	100 % ED	0...13	20077509	
				24/DC/5.5		0...11.5	20070693	
				24/50/4		0...13	20077511	
				230/50/4		0...13	20070709	
		1.6	48	24/DC/7		100 % ED	0...7.5	o. r.
				24/DC/5.5			0...6	o. r.
				24/50/4			0...7.5	o. r.
				230/50/4			0...7.5	o. r.
		2.0	75	24/DC/7		100 % ED	0...7	o. r.
				24/DC/5.5			0...5.5	o. r.
				24/50/4			0...6	o. r.
				230/50/4			0...6	o. r.
	BJ02 P: G 1/4 A: G 1/4	1.2	35	24/DC/7	100 % ED	0...13	20077512	
				24/DC/5.5		0...11.5	20077514	
				24/50/4		0...13	20077516	
				230/50/4		0...13	20077519	
		1.6	48	24/DC/7		100 % ED	0...7.5	o. r.
				24/DC/5.5			0...6	o. r.
				24/50/4			0...7.5	o. r.
				230/50/4			0...7.5	o. r.
		2.0	75	24/DC/7		100 % ED	0...7	o. r.
				24/DC/5.5			0...5.5	o. r.
				24/50/4			0...6	o. r.
				230/50/4			0...6	o. r.
BJ03 P: NPT 1/4 A: G 1/8	1.2	35	24/DC/7	100 % ED	0...13	20077523		
			24/DC/5.5		0...11.5	20077564		
			24/50/4		0...13	20077570		
			230/50/4		0...13	20077574		
	1.6	48	24/DC/7		100 % ED	0...7.5	o. r.	
			24/DC/5.5			0...6	o. r.	
			24/50/4			0...7.5	o. r.	
			230/50/4			0...7.5	o. r.	
	2.0	75	24/DC/7		100 % ED	0...7	o. r.	
			24/DC/5.5			0...5.5	o. r.	
			24/50/4			0...6	o. r.	
			230/50/4			0...6	o. r.	

DTS 1000446517 EN Version: H Status: RL (released | freigeben | validé) printed: 08.02.2024

Circuit function	Port connection	Orifice	Q _{Nn} value air	Voltage/Frequency/Power	Maximum duty cycle	Medium pressure ¹⁾²⁾	Article no.
						Ambient temperature max. +55 °C resp. +75 °C ³⁾	
		[mm]	[l/min]	[V/Hz/W]		Air	FKM seal
						[bar]	
CF C 3/2-way solenoid valve Direct-acting Normally closed 	BJ05 P: G ¼ A: G ½	1.2	35	24/DC/7	100 % ED	0...13	20077596 ☒
				24/DC/5.5		0...11.5	20077598 ☒
				24/50/4		0...13	20077604 ☒
				230/50/4		0...13	20077609 ☒
		1.6	48	24/DC/7	100% ED	0...7.5	o. r.
				24/DC/5.5		0...6	o. r.
				24/50/4		0...7.5	o. r.
				230/50/4		0...7.5	o. r.
		2.0	75	24/DC/7	100% ED	0...7	o. r.
				24/DC/5.5		0...5.5	o. r.
				24/50/4		0...6	o. r.
				230/50/4		0...6	o. r.
	BJ07 P: NPT ¼ A: G ½	1.2	35	24/DC/7	100 % ED	0...13	20077610 ☒
				24/DC/5.5		0...11.5	20077615 ☒
				24/50/4		0...13	20077618 ☒
				230/50/4		0...13	20077626 ☒
		1.6	48	24/DC/7	100% ED	0...7.5	o. r.
				24/DC/5.5		0...6	o. r.
				24/50/4		0...7.5	o. r.
				230/50/4		0...7.5	o. r.
		2.0	75	24/DC/7	100% ED	0...7	o. r.
				24/DC/5.5		0...5.5	o. r.
				24/50/4		0...6	o. r.
				230/50/4		0...6	o. r.

o. r.: on request

1.) Pressure data: overpressure to atmospheric pressure and air as a medium

2.) Number of switching cycles under laboratory conditions (FKM seal, oiled air, unpressurised, DC): 5 million. Please note that an increase in switching pressure can limit the life of the seat seal.

3.) Depending on the performance level

4.) For P1: 6 bar absolute and P2: 5 bar absolute

ATEX/IECEX cable version

Note:

- The maximum medium temperature may never exceed the permissible temperature class (T4 135 °C) minus 5K.
- Only single mounting permissible
- With 3 m cable as standard. Other lengths on request.

Circuit function	Port connection	Orifice	K _v value water ¹⁾	Voltage/Frequency/Power	Maximum duty cycle	Pressure range ²⁾	Article no.	
						Ambient temperature +55 °C	Brass body	Stainless steel body
		[mm]	[m³/h]	[V/Hz/W]		Air + water	FKM seal	
						[bar]		
CF C 3/2-way solenoid valve Direct-acting Normally closed 	G ½	1.2	0.045	24/AC/DC/6	100 % ED	0...8	20017950 ☒	20053187 ☒
				230/AC/DC/6		0...8	20017953 ☒	20053193 ☒
				24/AC/DC/6		0...11	20017952 ☒	20077468 ☒
				230/AC/DC/6		0...11	20077471 ☒	20077470 ☒
		1.6	0.060	24/AC/DC/6	100 % ED	0...4	20017954 ☒	20053195 ☒
				230/AC/DC/6		0...4	20017958 ☒	20053196 ☒
				24/AC/DC/6		0...5.5	20017957 ☒	20077485 ☒
				230/AC/DC/6		0...5.5	20077475 ☒	20077478 ☒
		2.0	0.110	24/AC/DC/6	100 % ED	0...3	20017961 ☒	20053197 ☒
				230/AC/DC/6		0...3	20010156 ☒	20053199 ☒
				24/AC/DC/6		0...4	20017959 ☒	20077490 ☒
				230/AC/DC/6		0...4	20025746 ☒	20077492 ☒

1.) Measurement at +20 °C, 1 bar²⁾ at the valve inlet and free outlet

2.) Pressure data: overpressure to atmospheric pressure and air as a medium

Additional options

Note:

Available on request

Option	Variable Code	Description
Oxygen versions	NL02	Suitable for applications with oxygen (non-metal materials that are in contact with the medium are tested and approved according to BAM)
Increased purity requirements e.g. oil, grease and silicone-free	NL50/NL05	Wetted parts are specially cleaned and packaged in accordance with the valves
Increased tightness requirements	PC05	Leakage rate *less than 10^{-4} mbar l/sec
	PC08	Leakage rate *less than 10^{-5} mbar l/sec
	PC06	Leakage rate *less than 10^{-6} mbar l/sec
Vacuum version	on request	–

8.5. Ordering chart accessories

Single manifold

Note:



Further ordering information can be found in chapter “5.5. Single manifold” on page 14.

Multiple manifold

Note:

Further ordering information can be found in chapter “5.6. Multiple manifold” on page 15.

Accessories for manifolds

Accessory	Features	Article no.
Screw plug	With sealing ring, G $\frac{1}{8}$	005041 
Cover plate	For unoccupied valve position	005100 

Cable plug Type 2516, form C according to DIN EN 175301 - 803

Note:

- Dimensions in mm
- Delivery of cable plug includes a flat seal and a fixing screw.
- For further versions see data sheet **Type 2516** ▶.

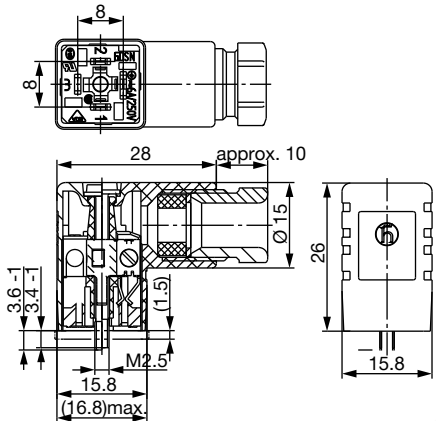
Cable plug	Dimensions	Version	Voltage	Article no.
		Without circuitry	0...250 V AC/DC	303141
		With LED	12...24 V AC/DC	303145
		With LED and varistor	12...24 V AC/DC	303148
		With rectifier, LED and varistor	12...24 V AC/DC	303142

Cable plug Type 2507, form B according to industry standard

Note:

- Dimensions in mm
- Delivery of cable plug includes a flat seal and a fixing screw.
- Refer to data sheet **Type 2507** ▶ for more information about the cable plug.

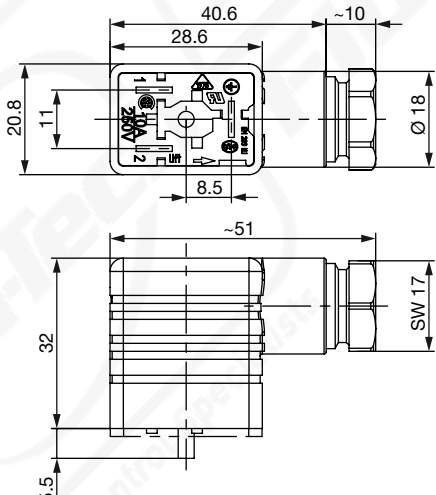
Cable plug	Dimensions	Version	Voltage	Article no.
		Without circuitry (standard)	2...250 V AC/DC	423845
		With LED	24 V AC/DC	423849
		With LED and free-wheeling diode	12...24 V AC/DC	423851
		With rectifier, LED and varistor	2...250 V AC/DC	423854
			12...24 V AC/DC	423853

DTS 1000446517 EN Version: H Status: RL (released | freigegeben | validé) printed: 08.02.2024