



Inline positive displacement (PD) flowmeter

- High accuracy
- Medium with high viscosity
- Mounting and dismounting of the electronics by a quarter-turn
- Connection to Bürkert devices in remote variants

Product variants described in the data sheet may differ from the product presentation and description.

Can be combined with

| | | |
|---|---|---|
|  | Type 8619 multiCELL - transmitter/controller | ▶ |
|  | Type 8025 Flow transmitter or remote batch controller | ▶ |
|  | Type 8611 eCONTROL - Universal controller | ▶ |
|  | Type 8022 Flow transmitter / Pulse divider | ▶ |
|  | Type 8801 ELEMENT On/Off Valve Systems with decentralized automation - overview | ▶ |
|  | Type 8802 ELEMENT continuous control valve systems - overview | ▶ |
|  | PLC | |

Type description

This positive displacement flowmeter Type SE30 + S077 is specially designed for continuous flow measurement of highly viscous fluids like glue, honey or oil.

The device is made up of a compact Inline sensor-fitting with oval gears (Type S077) and a transmitter with display (Type SE30). The device is quickly and easily assembled thanks to a bayonet mounting and locking system. The Bürkert "Inline quarter-turn" technology ensures a leakage-free operation.

The Bürkert designed sensor-fitting system ensures simple installation of the devices into all pipelines from DN 15...DN 100.

The flowmeter produces frequency signal (pulse), proportional to the flow rate, which can easily be transmitted and processed by a Bürkert transmitter (Type 8025, Type 8022, Type 8611, Type 8619...) oder a PLC.

DTS 1000285777 EN Version: H Status: RL (released | freigegeben | valide) printed: 13.12.2023

FLU-TECH CO. LTD.

Email: sales@flutech.co.th **Website:** https://flutech.co.th

Tel: 02-384-6060, 086-369-5871-3 **Fax:** 02-384-5701 **LINE OA:** @flutech.co.th

Address (HQ): 845/3-4, Moo 3, Theparak Rd., T. Theparak, A. Mueang Samut Prakan, Samut Prakan, 10270, Thailand



Table of contents

| | |
|---|----------|
| 1. General technical data | 3 |
| 2. Product versions | 5 |
| 3. Approvals and conformities | 5 |
| 3.1. Conformity | 5 |
| 3.2. Standards..... | 5 |
| 3.3. Pressure Equipment Directive (PED)..... | 5 |
| Device used on a pipe | 5 |
| 4. Materials | 6 |
| 4.1. Bürkert resistApp | 6 |
| 4.2. Material specifications | 6 |
| 5. Dimensions | 6 |
| 5.1. Transmitter Typ SE30 | 6 |
| 5.2. Transmitter Type SE30 mounted in an Inline sensor-fitting Type S077..... | 7 |
| 6. Product installation | 7 |
| 6.1. Installation notes | 7 |
| 7. Product operation | 8 |
| 7.1. Measuring principle..... | 8 |
| 8. Product design and assembly | 8 |
| 8.1. Product assembly | 8 |
| 9. Networking and combination with other Bürkert products | 9 |
| 10. Ordering information | 9 |
| 10.1. Bürkert eShop..... | 9 |
| 10.2. Recommendation regarding product selection..... | 9 |
| 10.3. Bürkert product filter..... | 10 |
| 10.4. Ordering chart..... | 10 |
| Flow transmitter Type SE30 | 10 |
| 10.5. Ordering chart accessories..... | 10 |

DTS 1000285777 EN Version: H Status: RL (released | freigegeben | validé) printed: 13.12.2023

1. General technical data

Note:

If the device is mounted in a humid environment or outside, then the maximum voltage allowed is **35 V DC** instead of 36 V DC.

Product properties

Material
 Make sure the device materials are compatible with the fluid you are using.
 Further information can be found in chapter **“4.1. Bürkert resistApp”** on page 6.

Further information on the materials can be found in chapter **“4.2. Material specifications”** on page 6.

Non wetted parts

| | |
|-------------------------|---|
| Cover (male fixed plug) | PC |
| Housing | PC |
| Screw | Stainless steel |
| Bayonet system | PC |
| Female cable plug | <ul style="list-style-type: none"> • Body, contact holder and cable gland in PA • Cable gland seal and flat seal in NBR |

Wetted parts

| | |
|---------------------|--|
| Axis | Stainless steel 316L (1.4401) |
| Oval gear | Stainless steel 316L (1.4401) |
| Sensor-fitting body | Aluminium, stainless steel 316L (1.4401) |
| Cover | Aluminium, stainless steel 316L (1.4401) |
| Seal | FKM or FEP/PTFE encapsulated |
| Compatibility | Any pipe from DN 15...DN 100 which is fitted with Bürkert S077 Inline sensor-fitting. For the selection of the nominal diameter of the Inline sensor-fittings, see data sheet Type S077 ▶. |
| Pipe diameter | DN 15...DN 100 |
| Dimensions | Further information can be found in chapter “5. Dimensions” on page 6. |
| Measuring principle | Oval gear |
| Measuring range | <ul style="list-style-type: none"> • Viscosity > 5 mPa.s: 2...1200 l/min (0.53...320 gpm) • Viscosity < 5 mPa.s: 3...616 l/min (0.78...320 gpm) |

Performance data

| | |
|-----------------------|--|
| Measurement deviation | <ul style="list-style-type: none"> • Teach-in or specific K factor, engraved on the Inline sensor-fitting: ±0.5 % of the measured value at Teach-In flow rate value • Standard K factor: ± 1 % of the measured value |
| Repeatability | ± 0.03 % of the measured value ¹⁾ |

Electrical data

| | |
|--------------------------------|--|
| Operating voltage | <ul style="list-style-type: none"> • Hall variant: 12...36 V DC ± 10 %, filtered and regulated Connection to main supply: permanent (through external SELV (Safety Extra Low Voltage) and LPS (Limited Power Source) power supply) • Hall “Low Power” variant: via the connected Bürkert transmitter |
| Power source (not supplied) | Limited power source according to UL/EN 62368-1 standards or limited energy circuit according to UL/EN 61010-1 paragraph 9.4 |
| DC reverse polarity protection | Yes |
| Current consumption | With sensor <ul style="list-style-type: none"> • Hall variant: ≤ 30 mA • Hall “Low Power” variant: ≤ 0.8 mA |

DTS 1000285777 EN Version: H Status: RL (released | freigegeben | valide) printed: 13.12.2023

| | |
|--------|---|
| Output | <ul style="list-style-type: none"> • Hall variant: <ul style="list-style-type: none"> – 2 transistors, pulse output – NPN and PNP, open collector – max. 100 mA – frequency: 0...300 Hz – NPN output: 0.2...36 V DC – PNP output: supply voltage – duty cycle (pulse duration/period): $\frac{1}{2} \pm 10\%$ • Hall “Low Power” variant: <ul style="list-style-type: none"> – 1 transistor, pulse output – NPN, open collector – max. 10 mA – frequency: 0...300 Hz – duty cycle (pulse duration/period): $\frac{1}{2} \pm 10\%$ |
|--------|---|

| | |
|----------------------|---|
| Voltage supply cable | <ul style="list-style-type: none"> • Cable with maximum operating temperature greater than 80 °C • Max. 50 m length, shielded • External diameter of wire: 5...8 mm • Cross section of wires: 0.25...1.5 mm² |
|----------------------|---|

Medium data

| | |
|-------------------|--|
| Fluid temperature | <p>With Inline sensor-fitting Type S077 in:</p> <ul style="list-style-type: none"> • Aluminium: -20...+80 °C (-4...+176 °F) • Stainless steel: -20...+120 °C (-4...+248 °F) <p>See data sheet Type S077 ▶ for more information.</p> |
|-------------------|--|

| | |
|----------------|--|
| Fluid pressure | <p>With Inline sensor-fitting Type S077 with:</p> <ul style="list-style-type: none"> • DN 15: max. 55 bar (798.05 PSI) (threaded process connection) • DN 25: max. 55 bar (798.05 PSI)¹⁾ • DN 40 or DN 50: max. 18 bar (261.18 PSI) • DN 80: max. 12 bar (174.12 PSI) • DN 100: max. 10 bar (145.1 PSI) <p>See data sheet Type S077 ▶ for more information.</p> |
|----------------|--|

| | |
|-----------|---------------------------------|
| Viscosity | Max. 1 Pa.s (higher on request) |
|-----------|---------------------------------|

| | |
|-------------------------|----|
| Rate of solid particles | 0% |
|-------------------------|----|

Process/Pipe connection & communication

| | |
|-----------------|---|
| Pipe connection | <p>With Inline sensor-fitting Type S077 with:</p> <ul style="list-style-type: none"> • Thread: $\frac{1}{2}$", 1", 1½", 2" or 3" (G or NPT) • Flange: <ul style="list-style-type: none"> – 25, 40, 50, 80 or 100 mm DIN PN 16 flange – 1", 1½", 2", 3" or 4" ANSI 150LB flange <p>See data sheet Type S077 ▶ for more information.</p> |
|-----------------|---|

| | |
|-----------------------|--|
| Electrical connection | Female cable plug according to DIN EN 175301-803 |
|-----------------------|--|

Approvals and conformities

Directives

| | |
|------------------------------|--|
| CE directive | Further information on the CE Directive can be found in chapter “3.2. Standards” on page 5. |
| Pressure equipment directive | Complying with article 4, paragraph 1 of 2014/68/EU directive Further information on the pressure equipment directive can be found in chapter “3.3. Pressure Equipment Directive (PED)” on page 5. |

Environment and installation

| | |
|------------------------|---|
| Ambient temperature | Operation and storage: 0...+60 °C (+32...+140 °F) |
| Relative air humidity | ≤80 %, without condensation |
| Height above sea level | Max. 2000 m |
| Operating condition | Continuous |
| Equipment mobility | Fixed |
| Application range | Indoor and outdoor Protect the device against electromagnetic interference, ultraviolet rays and, when installed outdoors, against the effects of climatic conditions. |

DTS 1000285777 EN Version: H Status: RL (released | freigegeben | validé) printed: 13.12.2023

| | |
|--|--|
| Degree of protection according to IEC/EN 60529 | IP65 under the following simultaneous conditions: <ul style="list-style-type: none"> • device wired • cable plug mounted and tightened |
| Installation category | Category I according to UL/EN 61010-1 |
| Pollution degree | Degree 2 according to UL/EN 61010-1 |

1.) Or in accordance to the value of the used flanges

2. Product versions

The flowmeter is available with frequency output in two variants:

- **Hall variant** with two transistor outputs NPN and PNP.
The flowmeter requires an external power supply of 12...36 V DC. The output signal is designed for connection to any system with open collector NPN or PNP frequency input.
This variant is intended, for example, for connection to Universal flow transmitters or batch controller Type 8025, to pulse divider Type 8022, to eCONTROL universal controller Type 8611 or to multiCELL transmitter/controller Type 8619.
See [data sheet Type 8025](#) ▶, [data sheet Type 8022](#) ▶, [data sheet Type 8611](#) ▶, [data sheet Type 8619](#) ▶ for more information.
- **Hall “Low Power” variant** with one NPN transistor “Low Power” output.
The flowmeter requires an external power supply of 12...36 V DC, provided by the connected Bürkert transmitter.
This variant is **only** intended for connection to the Bürkert device Type 8025 in its flow transmitter for “Low Power” flowmeters Type 8025 or to 4...20 mA flow transmitter Type 8022.
See [data sheet Type 8025](#) ▶, [data sheet Type 8022](#) ▶ for more information.

In a 3-wire system, the signal can be connected to a display or processed directly. The electrical connection is provided via a cable plug according to DIN EN 175301-803.

3. Approvals and conformities

3.1. Conformity

In accordance with the Declaration of Conformity, the product is compliant with the EU Directives.

3.2. Standards

The applied standards which are used to demonstrate compliance with the EU Directives are listed in the EU-Type Examination Certificate and/or the EU Declaration of Conformity.

3.3. Pressure Equipment Directive (PED)

The device conforms to article 4, paragraph 1 of the Pressure Equipment Directive (PED) 2014/68/EU under the following conditions:

Device used on a pipe

Note:

- The data in the table is independent of the chemical compatibility of the material and the fluid.
- PS = maximum admissible pressure (in bar), DN = nominal diameter of the pipe

| Type of fluid | Conditions |
|--|-------------------------------------|
| Fluid group 1, article 4, paragraph 1.c.i | DN ≤ 25 |
| Fluid group 2, article 4, paragraph 1.c.i | DN ≤ 32 or PS*DN ≤ 1000 |
| Fluid group 1, article 4, paragraph 1.c.ii | DN ≤ 25 or PS*DN ≤ 2000 |
| Fluid group 2, article 4, paragraph 1.c.ii | DN ≤ 200 or PS ≤ 10 or PS*DN ≤ 5000 |

DTS 1000285777 EN Version: H Status: RL (released | freigegeben | validé) printed: 13.12.2023

4. Materials

4.1. Bürkert resistApp

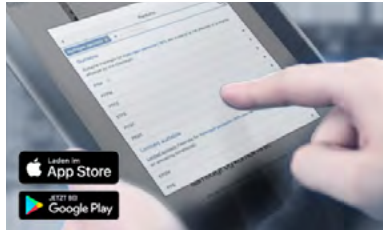

Bürkert resistApp – Chemical resistance chart

You want to ensure the reliability and durability of the materials in your individual application case? Verify your combination of media and materials on our website or in our resistApp.

[Start chemical resistance check](#)

4.2. Material specifications

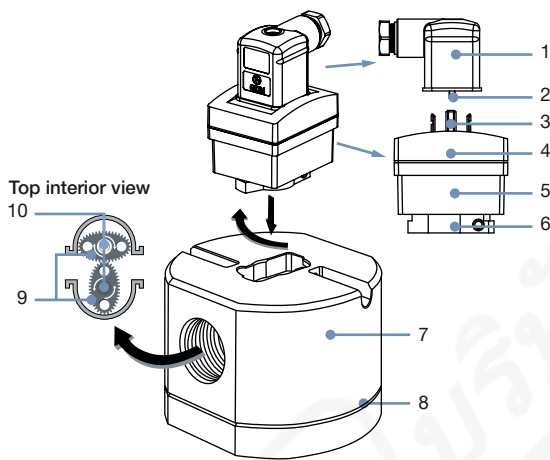

| No. | Element | Material |
|-----|---------------------------------------|---|
| 1 | Female cable plug (DIN EN 175301-803) | <ul style="list-style-type: none"> Body, contact holder and cable gland in PA Cable gland seal and flat seal in NBR |
| 2 | Screws | Stainless steel |
| 3 | Electrical contact | Sn |
| 4 | Cover (male fixed plug) | PC |
| 5 | Housing | PC |
| 6 | Quarter turn system | PC |
| 7 | Sensor-fitting body | Aluminium or stainless steel (316L) |
| 8 | Seal | FKM or FEP/PTFE encapsulated |
| 9 | Oval gear | PPS, aluminium or stainless steel (316L) |
| 10 | Axis | Stainless steel (316L) |

5. Dimensions

5.1. Transmitter Typ SE30

Note:

Dimensions in mm, unless otherwise stated

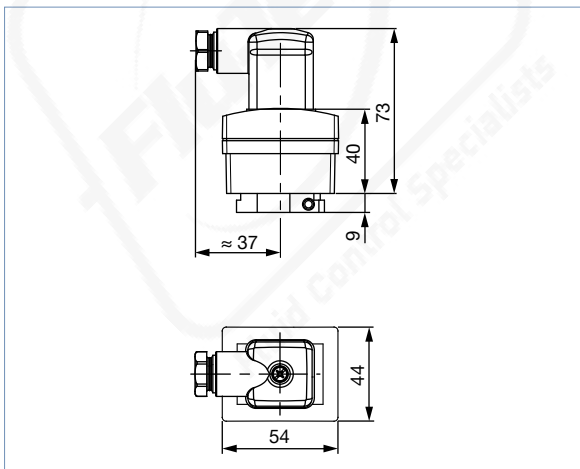

5.2. Transmitter Type SE30 mounted in an Inline sensor-fitting Type S077

Note:

Dimensions in mm, unless otherwise stated

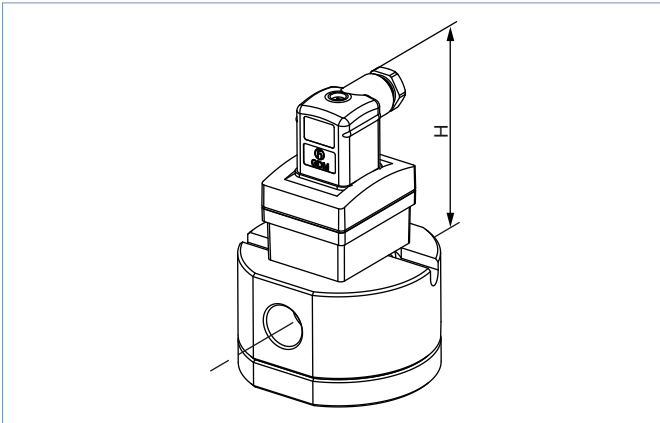

| DN | H |
|-----|-----|
| 15 | 94 |
| 25 | 103 |
| 40 | 115 |
| 50 | 125 |
| 80 | 175 |
| 100 | 191 |

DN 15 DN 25 DN 40 DN 50 DN 80

Threaded connection

DN 25 DN 40 DN 50 DN 80 DN 100

Flanged connection

6. Product installation

6.1. Installation notes

Note:

The device is not suitable for use in gaseous media and steam.

The sensor fitting can be installed in any orientation as long as **the rotor shafts are always in a horizontal plane.**

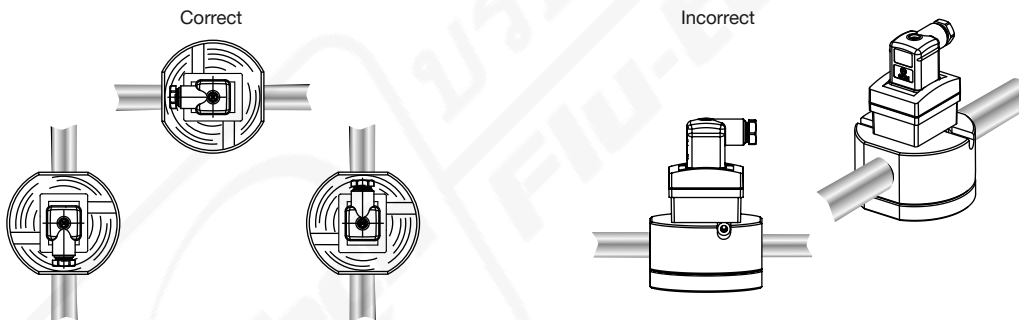

The following installation conditions must also be observed:

- The pipe always has to be filled with fluid at all times near the device.
- The pipe design must be such that no air bubbles or cavitation can form within the medium near the device at any time.
- We recommend the installation of a 250 µm strainer as close as possible to the inlet side of the meter, to prevent damage from particles,
- Air purges can damage the appliance and should therefore be avoided.

7. Product operation

7.1. Measuring principle

When liquid flows through the pipe, the rotors turn. This rotation produces a measuring signal in the associated Hall sensor. The rotation frequency of this signal is proportional to the flow velocity of the fluid. The volume of the fluid being transferred in this way is exactly determined through the sensor geometry.

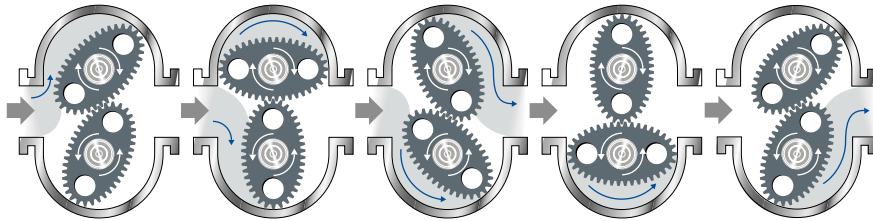

A conversion coefficient, specific to each meter size, enables the conversion of this frequency into a flow rate. The standard K factor depending on the meter size is available in the flowmeter's operating instructions, see **Type S077**. To improve the measurement deviation, a device-specific K factor is given on the device label.

8. Product design and assembly

8.1. Product assembly

Note:

- The device Type SE30 + S077 is made up of a Bürkert Inline sensor-fitting Type S077 equipped with a sensor with oval gears and a transmitter Type SE30.
- The Inline sensor-fitting Type S077 ensures simple installation into pipes from DN 15...DN 100. The transmitter Type SE30 can be mounted on any Inline sensor-fitting Type S077 and fastened with a bayonet catch, see **data sheet Type S077** for more information.

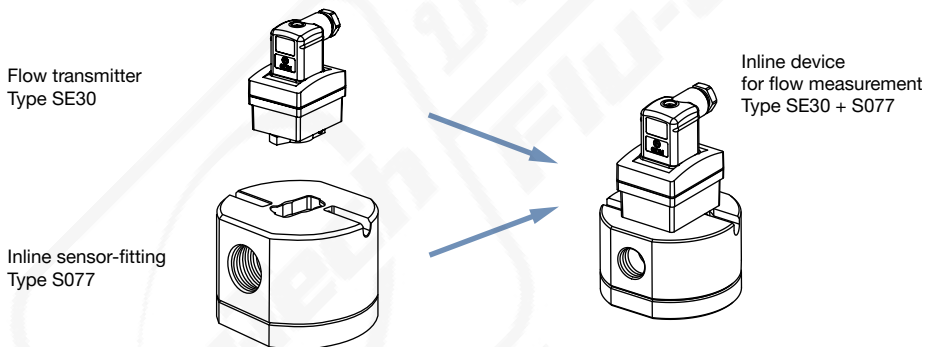

DTS 1000285777 EN Version: H Status: RL (released | freigegeben | validé) printed: 13.12.2023

9. Networking and combination with other Bürkert products

Example:

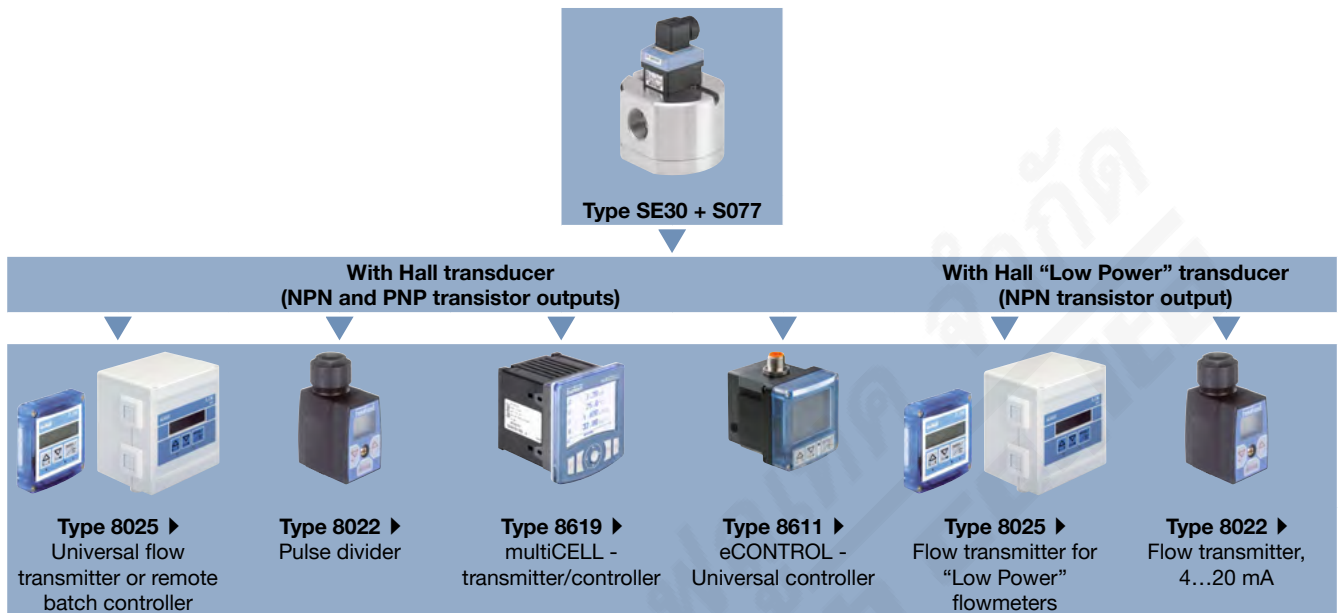

10. Ordering information

10.1. Bürkert eShop



Bürkert eShop – Easy ordering and quick delivery

You want to find your desired Bürkert product or spare part quickly and order directly? Our online shop is available for you 24/7. Sign up and enjoy all the benefits.

[Order online now](#)

10.2. Recommendation regarding product selection

A complete flowmeter Type SE30 + S077 consists of a flow transmitter Type SE30 and an Inline sensor-fitting Type S077.

See **data sheet Type S077** ▶ for more information.

Two different components must be ordered in order to select a complete device. The following information is required:

- **Article no.** of the compact Type SE30 flow transmitter (see chapter “10.4. Ordering chart” on page 10)
- **Article no.** of the selected Type S077 Inline sensor-fitting (see **data sheet Type S077** ▶)

10.3. Bürkert product filter

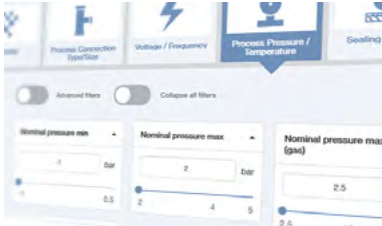

Bürkert product filter – Get quickly to the right product

You want to select products comfortably based on your technical requirements? Use the Bürkert product filter and find suitable articles for your application quickly and easily.

[Try out our product filter](#)

10.4. Ordering chart

Flow transmitter Type SE30

| Description | Operating voltage | Output | Electrical connection | Article no. |
|---|-----------------------------|---|-------------------------------------|-------------|
| Hall variant (connectable to Type 8025 universal transmitter, or batch controller, Type 8619, Type 8611, Type 8022 pulse divider or to a PLC) | 12...36 V DC | Frequency with pulse, transistors PNP and NPN, open collector | Female cable plug DIN EN 175301-803 | 423913 |
| Hall "Low Power" variant (only connectable to the flow transmitter for "Low Power" flowmeters Type 8025 or to the flow transmitter Typ 8022) | From associated transmitter | Frequency with pulse, transistor NPN, open collector | | 423914 |

10.5. Ordering chart accessories

| Description | Article no. |
|--|-------------|
| Female cable plug, 4-pin (3 conductors + protective conductor), form A according to DIN EN 175301-803, with cable gland (Type 2518 ▶) | 572264 |
| Female cable plug 32 mm, 4-pin (3 conductors + protective conductor), form A according to DIN EN 175301-803, with NPT 1/2" reduction without cable gland (Type 2509 ▶) | 162673 |

DTS 1000285777 EN Version: H Status: RL (released | freigegeben | valide) printed: 13.12.2023