







**Flow transmitter to use on Inline sensor-fitting for hazardous areas II 1 G/D - II 3 GD**

- Flowmeter with NAMUR or NPN/PNP output signal
- Mounting, dismounting of electronics by a Quarter-Turn
- Protection-Ex:
  - Intrinsically safe (ignition protection type i) certified NAMUR variant for use in Zone 0, 1, 2 - Gas (G) or 20, 21, 22 - Dust (D)
  - non-sparking (ignition protection type ec) certified NPN/PNP variant for use in Zone 2 - Gas (G) or 22 - Dust (D)3

Product variants described in the data sheet may differ from the product presentation and description.

**Can be combined with**

-  **Type 8619**  
multiCELL - transmitter/controller
-  **Type 8611**  
eCONTROL - Universal controller
-  **Type 8025**  
Flow transmitter or remote batch controller
-  **Intrinsic safety barrier**  
with NAMUR input
-  **PLC**

**Type description**

The flow transmitter Type SE30 Ex for continuous flow measurement is especially designed for use in neutral, slightly aggressive, solid-free liquids, in hazardous environments.

The complete flowmeter is made up of an electronic module and a measuring element, either a Inline sensor-fitting Type S030 with PVDF paddle-wheel or a Inline sensor-fitting Type S077, quickly and easily connected together by a Quarter-Turn.

The electronic module detects the paddle-wheel (Type S030) or oval gear (Type S077) rotation, modulates the current of the power supply line according to NAMUR standard or produces an NPN/PNP output signal (depends on model). To operate the NAMUR signal, an intrinsic safety barrier should be connected to the flowmeter Type SE30 Ex.

The connection to another device in the safe area depends on the used flowmeter model.

DTS 1000049988 EN Version: X Status: RL (released | freigegeben | valide) printed: 21.08.2024

**FLU-TECH CO. LTD.**

**Email:** sales@flutech.co.th **Website:** https://flutech.co.th

**Tel:** 02-384-6060, 086-369-5871-3 **Fax:** 02-384-5701 **LINE OA:** @flutech.co.th

**Address (HQ):** 845/3-4, Moo 3, Theparak Rd., T. Theparak, A. Mueang Samut Prakan, Samut Prakan, 10270, Thailand



## Table of contents

|   |           |
|---|-----------|
| <b>1. General technical data</b>  | <b>3</b>  |
| 1.1. About the device.....  | 3         |
| 1.2. All variants.....  | 3         |
| 1.3. Transmitter with a Namur output signal .....   | 4         |
| 1.4. Transmitter with an NPN/PNP output signal.....   | 5         |
| <b>2. Approvals and conformities</b>  | <b>5</b>  |
| 2.1. Conformity .....   | 5         |
| 2.2. Standards.....   | 5         |
| 2.3. Explosion protection.....  | 5         |
| <b>3. Materials</b>   | <b>6</b>  |
| 3.1. Bürkert resistApp.....   | 6         |
| 3.2. Material specifications.....   | 6         |
| <b>4. Dimensions</b>  | <b>7</b>  |
| 4.1. Transmitter Type SE30 Ex, variant NAMUR.....   | 7         |
| 4.2. Transmitter Type SE30 Ex, variant PNP/NPN.....   | 7         |
| 4.3. Transmitter Type SE30 Ex mounted on a Type S030 sensor-fitting.....                                    | 8         |
| 4.4. Transmitter Type SE30 Ex mounted on a Type S077 sensor-fitting .....                                   | 8         |
| <b>5. Performance specifications</b>  | <b>9</b>  |
| 5.1. Pressure temperature diagram .....   | 9         |
| <b>6. Product installation</b>  | <b>9</b>  |
| 6.1. Installation notes.....  | 9         |
| Installation into Type S030 sensor fitting.....   | 9         |
| Installation into Type S077 sensor fitting .....  | 10        |
| 6.2. Overview of hazardous areas depending on Type SE30 Ex flow transmitter models (according to ATEX)..... | 11        |
| 6.3. Safety instructions - Notice of ATEX instructions.....   | 11        |
| <b>7. Product operation</b>   | <b>13</b> |
| 7.1. Measuring principle .....  | 13        |
| <b>8. Product design and assembly</b>   | <b>13</b> |
| 8.1. Product assembly .....   | 13        |
| <b>9. Product accessories</b>   | <b>14</b> |
| <b>10. Networking and combination with other Bürkert products</b>   | <b>15</b> |
| 10.1. Type SE30 Ex with marking II 1 G/D (NAMUR variant).....   | 15        |
| 10.2. Type SE30 Ex with marking II 3 GD (NPN/PNP variant) .....   | 15        |
| <b>11. Ordering information</b>   | <b>15</b> |
| 11.1. Bürkert eShop .....   | 15        |
| 11.2. Recommendation regarding product selection.....   | 16        |
| 11.3. Bürkert product filter.....   | 16        |
| 11.4. Ordering chart .....  | 16        |
| 11.5. Ordering chart accessories.....   | 16        |
| Cable plug.....   | 16        |
| Intrinsic safety barrier .....  | 16        |

# 1. General technical data

## 1.1. About the device

A complete flowmeter for hazardous areas is available

- either with a Namur output signal (variant NAMUR)
- or with an NPN/PNP output signal (variant NPN/PNP)

and with a wide variety of process connection according to the sensor-fitting Type S030 or Type S077 on which the transmitter Type SE30 Ex is mounted.

Further information can be found in [data sheet Type S030](#) or [data sheet Type S077](#) and further information on the restrictions on the use of sensors can be found in chapter [“6.3. Safety instructions - Notice of ATEX instructions” on page 11.](#)

## 1.2. All variants

The following data applies to all variants.

| Product properties  |   |
|---|---|
| <b>Material</b>   |   |
| Make sure the device materials are compatible with the fluid you are using. Further information can be found in chapter <a href="#">“3.1. Bürkert resistApp” on page 6.</a> |   |
| Further information on the materials can be found in chapter <a href="#">“3.2. Material specifications” on page 6.</a>  |   |
| <b>Non wetted parts</b>   |   |
| Screw   | Stainless steel   |
| Female cable plug   | <ul style="list-style-type: none"> <li>• Body, contact holder and cable gland in PA</li> <li>• Cable gland seal and flat seal in silicone</li> </ul>  |
| <b>Wetted parts</b>   |   |
| Sensor-fitting body   | Depend on the selected sensor-fitting Type. Further information on sensor-fitting can be found in the data sheet of the used Inline sensor-fittings, see <a href="#">data sheet Type S030</a> or <a href="#">data sheet Type S077</a> and restrictions on the use of the sensors can be found in chapter <a href="#">“6.3. Safety instructions - Notice of ATEX instructions” on page 11.</a>   |
| Compatibility   | <ul style="list-style-type: none"> <li>• Any pipe from DN 06...DN 65 which are fitted with Bürkert Type S030 Inline sensor-fitting. For the selection of the nominal diameter and materials of the Inline sensor-fittings, see <a href="#">data sheet Type S030</a>.</li> <li>• Any pipe from DN 15...DN 50 which is fitted with Bürkert Type S077 Inline sensor-fitting. For the selection of the nominal diameter and materials of the Inline sensor-fittings, see <a href="#">data sheet Type S077</a>.</li> </ul> <p>Further information on the restrictions on the use of sensors can be found in chapter <a href="#">“6.3. Safety instructions - Notice of ATEX instructions” on page 11.</a></p> |
| Dimensions  | Further information can be found in chapter <a href="#">“4. Dimensions” on page 7.</a>  |
| Measuring range   | <ul style="list-style-type: none"> <li>• Used with Type S030 sensor-fitting<br/>Flow rate: 0.5...1200 l/min (0.13...317 gpm) with flow velocity: 0.3...10 m/s</li> <li>• Used with Type S077 sensor-fitting<br/>Flow rate: 2...350 l/min (0.53...92.46 gpm) with viscosity &gt; 5 cps or 3...300 l/min (0.79...79.25 gpm) with viscosity &lt; 5 cps</li> </ul>  |
| Performance data  |   |
| Measurement deviation   | <ul style="list-style-type: none"> <li>• Used with Type S030 sensor-fitting:                             <ul style="list-style-type: none"> <li>– Teach-In (via a connected remote transmitter, e.g. Type 8025 ): ± 1% of the measured value<sup>1)</sup> (at Teach-In flow rate value)</li> <li>– Standard K-factor: ± 2.5 % of the measured value<sup>1)</sup></li> </ul> </li> <li>• Used with Type S077 sensor-fitting: ± 0.5 % of the measured value</li> </ul>  |
| Linearity   | ± 0.5 % of full scale <sup>1)</sup>   |
| Repeatability   | <ul style="list-style-type: none"> <li>• Used with Type S030 sensor-fitting: ± 0.4 % of the measured value<sup>1)</sup></li> <li>• Used with Type S077 sensor-fitting: ± 0.3 % of the measured value</li> </ul>   |
| Electrical data   |   |
| Protection against DC polarity reversal   | Yes   |

DTS 1000049988 EN Version: X Status: RL (released | freigegeben | valide) printed: 21.08.2024

|                      |   |
|----------------------|---|
| Voltage supply cable | <ul style="list-style-type: none"> <li>• Cable with maximum operating temperature greater than 80 °C</li> <li>• Max. 50 m length, shielded</li> <li>• External diameter of wire: 5...8 mm</li> <li>• Cross section of wires: 0.5...1.5 mm<sup>2</sup></li> <li>• Cross section the local ground wire: max. 0.75 mm<sup>2</sup></li> <li>• Line impedance of the conductors:&lt; 50 Ω</li> </ul> |
|----------------------|---|

**Medium data**

|                   |                         |
|-------------------|-------------------------|
| Fluid temperature | Max. + 80 °C (+ 176 °F) |
|-------------------|-------------------------|

**Approvals and conformities**

**Directives**

|                      |   |
|----------------------|---|
| CE directive         | Further information on the CE Directive can be found in chapter <b>"2.2. Standards" on page 5.</b>  |
| Explosion protection | ATEX<br>Further information on the ATEX certification can be found in chapter <b>"6.3. Safety instructions - Notice of ATEX instructions" on page 11.</b> |

**Environment and installation**

|   |   |
|---|---|
| Ambient temperature                             | Operation and storage: - 15...+ 60 °C (+ 32...+ 140 °F)   |
| Relative air humidity                           | ≤ 80 %, without condensation  |
| Height above sea level                          | Max. 2000 m   |
| Operating condition                             | Continuous  |
| Equipment mobility                              | Fixed   |
| Application range                               | Indoor and outdoor<br>Protect the device against electromagnetic interference, ultraviolet rays and, when installed outdoors, against the effects of climatic conditions. |
| Degree of protection according to IEC/ EN 60529 | IP67 with connector plugged-in and tightened  |
| Installation category                           | Category I according to UL/EN 61010-1   |
| Pollution degree                                | Degree 2 according to UL/EN 61010-1   |

1.) Under reference conditions i.e. measuring medium = water, ambient and water temperature = + 20 °C (+ 68 °F), observing the minimum the minimum inlet and outlet sections and the appropriate inner diameter of the pipe.

**1.3. Transmitter with a Namur output signal**

**Product properties**

**Material**

**Non wetted parts**

|                         |                             |
|-------------------------|-----------------------------|
| Cover (male fixed plug) | PPS, glass fibre reinforced |
| Housing                 | PPS, glass fibre reinforced |
| Bayonet system          | PPS, glass fibre reinforced |

**Electrical data**

|                                 |  |
|---------------------------------|--|
| Operating voltage <sup>1)</sup> | 8...15 V DC (from connected intrinsic safety barrier)        |
| Current consumption             | With sensor: ≤ 7 mA  |
| Output                          | 2-wire current modulation according to NAMUR (0.5 or 2.5 mA) |

**Connections & communication**

|                       |  |
|-----------------------|--|
| Electrical connection | Cable plug Form A acc. to EN 175301-803 (supplied) |
|-----------------------|--|

**Approvals and conformities**

|        |                     |
|--------|---------------------|
| Others | NAMUR: EN 60947-5-6 |
|--------|---------------------|

1.) To select a suitable power supply for the place of use, see chapter **"6.3. Safety instructions - Notice of ATEX instructions" on page 11.**

DTS 1000049988 EN Version: X Status: RL (released | freigegeben | validé) printed: 21.08.2024

### 1.4. Transmitter with an NPN/PNP output signal

| Product properties              |   |
|---------------------------------|---|
| <b>Material</b>                 |   |
| <b>Non wetted parts</b>         |   |
| Cover (male fixed plug)         | PC  |
| Housing                         | PC  |
| Bayonet system                  | PC  |
| Electrical data                 |   |
| Operating voltage <sup>1)</sup> | 12...36 V DC  |
| Current consumption             | 30 mA   |
| Output                          | NPN/PNP   |
| Connections & communication     |   |
| Electrical connection           | Cable plug Form A acc. to EN 175301-803 with 5 or 12 m cable (not supplied) |

1.) To select a suitable power supply for the place of use, see chapter "6.3. Safety instructions - Notice of ATEX instructions" on page 11.

## 2. Approvals and conformities

### 2.1. Conformity

In accordance with the Declaration of Conformity, the product is compliant with the EU Directives.

### 2.2. Standards

The applied standards which are used to demonstrate compliance with the EU Directives are listed in the EU-Type Examination Certificate and/or the EU Declaration of Conformity.

### 2.3. Explosion protection

| Approval   | Description  |                 |                 |  |  |  |  |
|--|--|-----------------|-----------------|--|--|--|--|
|  | <p><b>Optional: Explosion protection</b><br/>Ex marking of the components according to the following table:</p> <table border="1"> <thead> <tr> <th>NAMUR variant</th> <th>NPN/PNP variant</th> </tr> </thead> <tbody> <tr> <td>As category 1 device suitable for zone 0, 1 and 2/20, 21 and 22.</td> <td>As category 3 device suitable for zone 2/22.</td> </tr> <tr> <td> <p><b>ATEX</b></p> <ul style="list-style-type: none"> <li>• II 1 GD Ex ia IIC T6</li> <li>• Ex iaD 20 IP6X T80 °C</li> </ul> </td> <td> <p><b>ATEX</b></p> <ul style="list-style-type: none"> <li>• II 3 GD</li> <li>• Ex ec IIC T4 Gc</li> <li>• Ex tc IIIC T135 °C Dc IP6Xc</li> </ul> </td> </tr> </tbody> </table> | NAMUR variant   | NPN/PNP variant | As category 1 device suitable for zone 0, 1 and 2/20, 21 and 22. | As category 3 device suitable for zone 2/22. | <p><b>ATEX</b></p> <ul style="list-style-type: none"> <li>• II 1 GD Ex ia IIC T6</li> <li>• Ex iaD 20 IP6X T80 °C</li> </ul> | <p><b>ATEX</b></p> <ul style="list-style-type: none"> <li>• II 3 GD</li> <li>• Ex ec IIC T4 Gc</li> <li>• Ex tc IIIC T135 °C Dc IP6Xc</li> </ul> |
|  | NAMUR variant  | NPN/PNP variant |                 |  |  |  |  |
| As category 1 device suitable for zone 0, 1 and 2/20, 21 and 22.   | As category 3 device suitable for zone 2/22.   |                 |                 |  |  |  |  |
| <p><b>ATEX</b></p> <ul style="list-style-type: none"> <li>• II 1 GD Ex ia IIC T6</li> <li>• Ex iaD 20 IP6X T80 °C</li> </ul>   | <p><b>ATEX</b></p> <ul style="list-style-type: none"> <li>• II 3 GD</li> <li>• Ex ec IIC T4 Gc</li> <li>• Ex tc IIIC T135 °C Dc IP6Xc</li> </ul>   |                 |                 |  |  |  |  |
| <p>Measures to comply with ATEX requirements: refer to</p> <ul style="list-style-type: none"> <li>• chapter "6.3. Safety instructions - Notice of ATEX instructions" on page 11 or</li> <li>• <b>Additional information PX011-PX12-PX13   Use in the explosion-hazardous area</b> ▶ under user manual.</li> </ul> <p>The Ex certification is only valid if the Bürkert device is used as described in the supplement ATEX. If unauthorized changes are made to the device, the Ex certification becomes invalid.</p> |  |                 |                 |  |  |  |  |

DTS 1000049988 EN Version: X Status: RL (released | freigegeben | validé) printed: 21.08.2024

### 3. Materials

#### 3.1. Bürkert resistApp

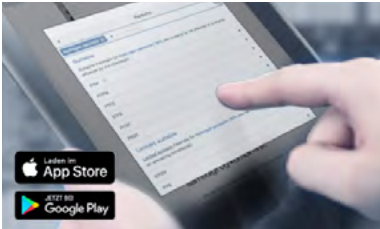

**Bürkert resistApp – Chemical resistance chart**

You want to ensure the reliability and durability of the materials in your individual application case? Verify your combination of media and materials on our website or in our resistApp.

[Start chemical resistance check](#)

#### 3.2. Material specifications

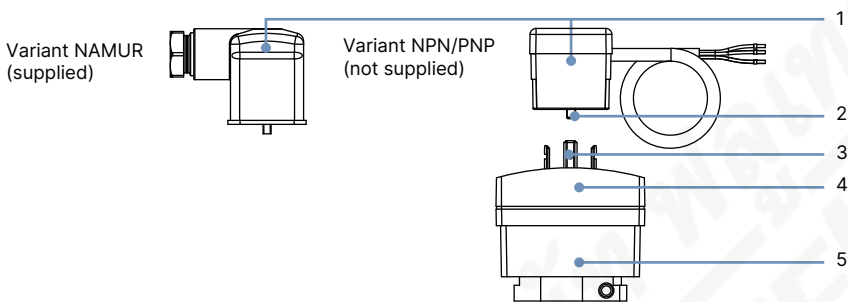

| No. | Description             | Material  |
|-----|-------------------------|---|
| 1   | Female cable plug       | <ul style="list-style-type: none"> <li>Variant Namur: PA with silicone seal</li> <li>Variant PNP/NPN: PA with NBR seal</li> </ul> |
| 2   | Screws                  | Stainless steel   |
| 3   | Electrical contact      | Sn  |
| 4   | Cover (male fixed plug) | PC  |
| 5   | Housing                 | <ul style="list-style-type: none"> <li>Variant Namur: PPS, glass fibre reinforced</li> <li>Variant PNP/NPN: PC</li> </ul>         |

DTS 1000049988 EN Version: X Status: RL (released | freigegeben | validé) printed: 21.08.2024

## 4. Dimensions

### 4.1. Transmitter Type SE30 Ex, variant NAMUR

**Note:**

- Dimensions in mm, unless otherwise stated
- The cable plug (DIN EN 175301-803) is supplied in the scope of delivery.

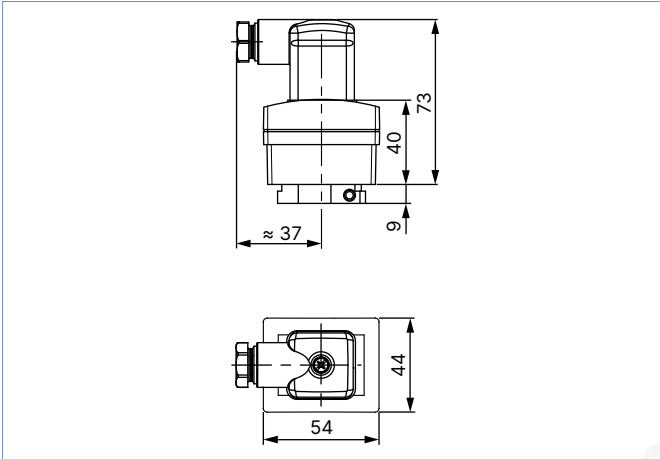

### 4.2. Transmitter Type SE30 Ex, variant PNP/NPN

**Note:**

- Dimensions in mm, unless otherwise stated
- The cable plug Type 2513 with 5 m cable or 12 m cable is not supplied in the scope of delivery and must be ordered separately. The cable outlet is **always oriented perpendicularly** to the pipeline, see **data sheet Type 2513** ▶.

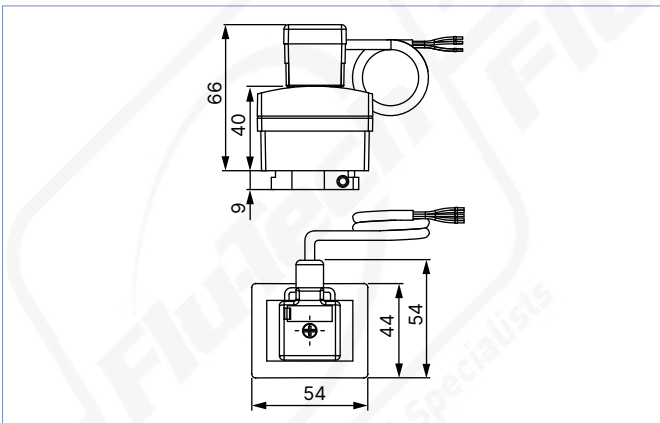

### 4.3. Transmitter Type SE30 Ex mounted on a Type S030 sensor-fitting

**Note:**

- Dimensions in mm, unless otherwise stated
- The cable plug (DIN EN 175301-803) is supplied in the scope of delivery.
- The cable plug Type 2513 with 5 m cable or 12 m cable is not supplied in the scope of delivery and must be ordered separately. The cable outlet is **always oriented perpendicularly** to the pipeline, see **data sheet Type 2513** ▶.

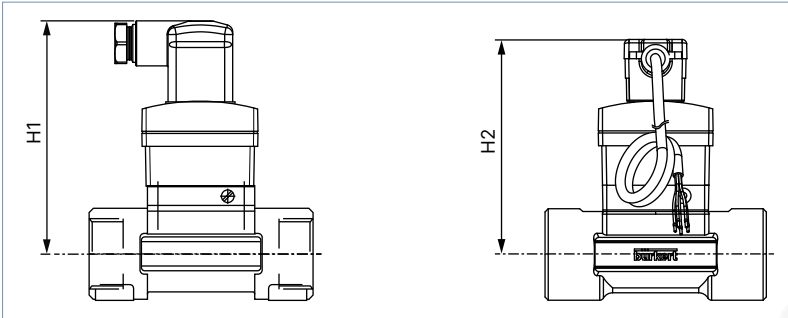

| DN | H1    | H2    |
|----|-------|-------|
| 06 | 102.5 | 95.5  |
| 08 | 102.5 | 95.5  |
| 15 | 107.5 | 100.5 |
| 20 | 105.0 | 98.0  |
| 25 | 105.0 | 98.0  |
| 32 | 109.0 | 102.0 |
| 40 | 112.5 | 105.5 |
| 50 | 117.0 | 112.0 |
| 65 | 117.0 | 112.0 |

### 4.4. Transmitter Type SE30 Ex mounted on a Type S077 sensor-fitting

**Note:**

- Dimensions in mm, unless otherwise stated
- The cable plug (DIN EN 175301-803) is supplied in the scope of delivery.
- The cable plug Type 2513 with 5 m cable or 12 m cable is not supplied in the scope of delivery and must be ordered separately. The cable outlet is **always oriented perpendicularly** to the pipeline, see **data sheet Type 2513** ▶.

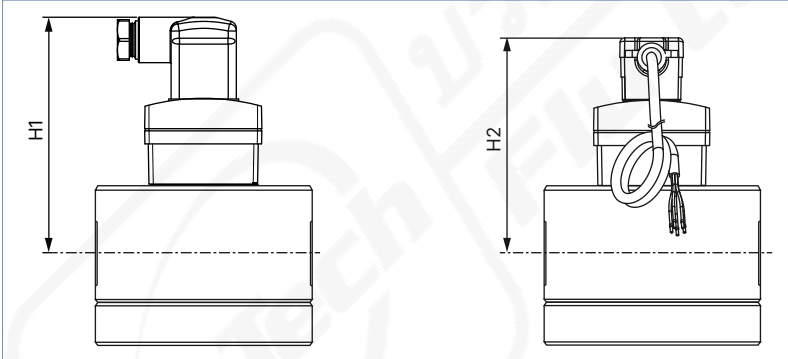

| DN | H1  | H2  |
|----|-----|-----|
| 15 | 94  | 87  |
| 25 | 103 | 96  |
| 40 | 115 | 108 |
| 50 | 125 | 118 |
| 80 | 175 | 168 |

|                     |       |       |       |       |
|---------------------|-------|-------|-------|-------|
| DN 15               | DN 25 | DN 40 | DN 50 | DN 80 |
| Threaded connection |       |       |       |       |
| DN 25               | DN 40 | DN 50 | DN 80 |       |
| Flanged connection  |       |       |       |       |

DTS 1000049988 EN Version: X Status: RL (released | freigegeben | validé) printed: 21.08.2024

FLUTECH  
Fluid Control Specialists



## 5. Performance specifications

### 5.1. Pressure temperature diagram

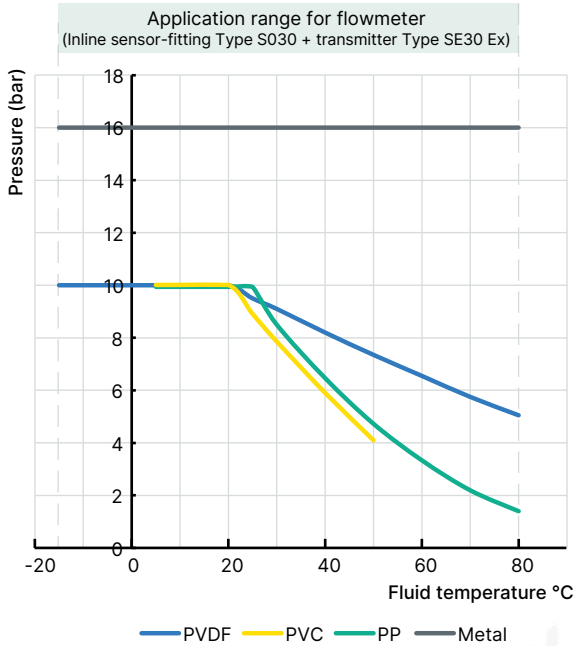

## 6. Product installation

### 6.1. Installation notes

#### Installation into Type S030 sensor fitting

**Note:**

The device is not suitable for use in gaseous media and steam.

Minimum straight distances upstream and downstream of the sensor must be observed. These stabilizing distances depend on the pipe's design. Increasing these distances or installing a flow conditioner may be necessary to obtain the best accuracy. For more information, refer to EN ISO 5167-1.

EN ISO 5167-1 specifies the straight inlet and outlet distances that must be complied with when installing fittings in pipe lines in order to achieve calm flow conditions. The most commonly used elements that could lead to turbulence in the flow are shown below. The related minimum inlet and outlet distances that ensure a calm flow are also specified.

Make sure that the measuring conditions at the point of measurement are calm and problem-free.

DN = Orifice

Fluid direction →

Regulating valve<sup>1)</sup>

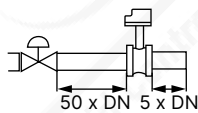

2 x 90° elbow joint

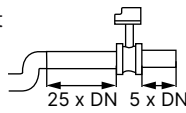

Expansion<sup>2)</sup>

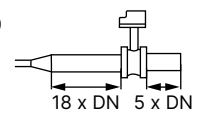

2 x 90° elbow joint  
3 dimensional

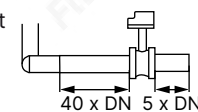

90° elbow joint  
or T-piece

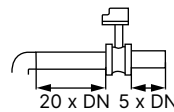

Reduction

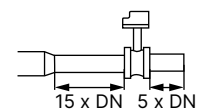

1.) If the valve cannot be mounted after the measuring device, the minimal distances have to be respected.

2.) If an expansion cannot be avoided, the minimal distances have to be respected.  
Please note minimum flow velocity

The device can be installed in either horizontal or vertical pipes, but following additional conditions should be respected:

- The pipe always has to be filled with fluid at all times near the device.

- The pipe design must be such that no air bubbles or cavitation can form within the medium near the device at any time.

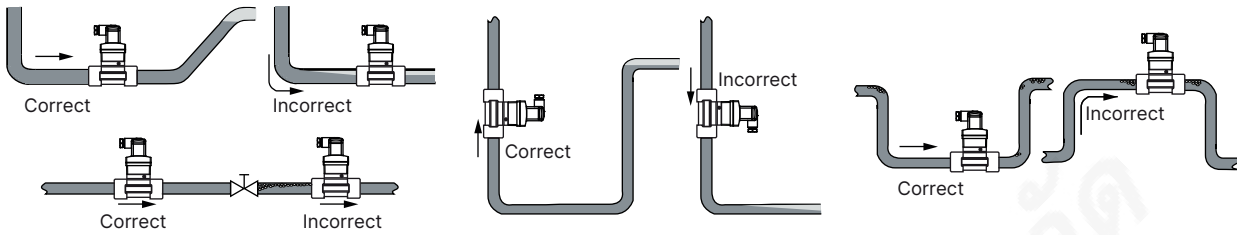

Pressure and temperature ratings must be respected according to the selected fitting material. The suitable pipe size is selected using the diagram in the chapter "Nominal size selection" of the **data sheet Type S030** and further information for using restriction can be found in chapter "6.3. Safety instructions - Notice of ATEX instructions" on page 11.

**Installation into Type S077 sensor fitting**

**Note:**

The device is not suitable for use in gaseous media and steam.

The sensor fitting can be installed in any orientation as long as **the rotor shafts are always in a horizontal plane.**

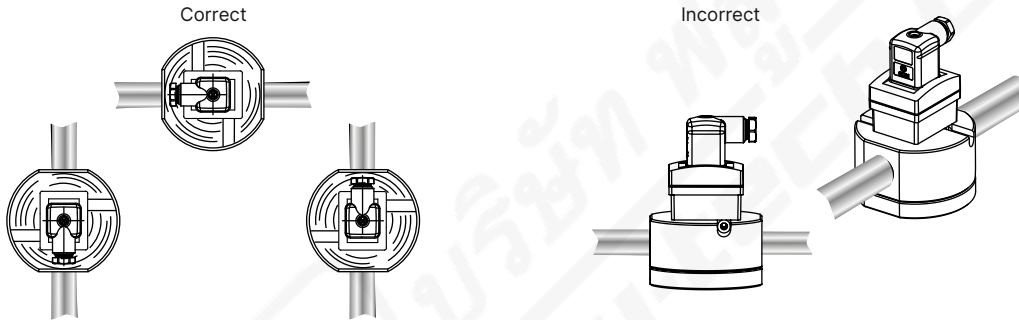

The following installation conditions must also be observed:

- The pipe always has to be filled with fluid at all times near the device.
- The pipe design must be such that no air bubbles or cavitation can form within the medium near the device at any time.
- We recommend the installation of a 250 µm strainer as close as possible to the inlet side of the meter, to prevent damage from particles,
- Air purges can damage the appliance and should therefore be avoided.

DTS 1000049988 EN Version: X Status: RL (released | freigegeben | validé) printed: 21.08.2024

### 6.2. Overview of hazardous areas depending on Type SE30 Ex flow transmitter models (according to ATEX)

This equipment can be installed in some potentially explosive atmospheres (surface industries) and comply with the 2014/34/EU ATEX directives.

| Equipment for explosive atmospheres (surface industries) - GROUP II  |  |  |                     |                     |  |  |
|--|--|--|---------------------|---------------------|--|--|
| Level of protection  | Very high  |  | High                |                     | Normal   |  |
| Zone   | Gas, Zone 0  | Dust, Zone 20                                    | Gas, Zone 1         | Dust, Zone 21       | Gas, Zone 2  | Dust, Zone 22  |
| Explosive atmospheres  | Present continuously, long periods or frequently   | Present continuously, long periods or frequently | Are likely to occur | Are likely to occur | Are unlikely to occur or present only infrequently and for a short period only | Are unlikely to occur or present only infrequently and for a short period only |
| <b>CATEGORY 1</b><br><b>SE30 Ex - NAMUR II 1 G/D</b><br><b>(Article no. 552901)</b><br>EEx ia IIC T6 - IP6X T80 °C<br>associated with sensor fittings made of PVDF, brass, stainless steel or aluminium                      | To use with intrinsic safety barrier with NAMUR input (The open circuit voltage for the NAMUR input must be included between 8 and 15 V).  |  |                     |                     |  |  |
| <b>CATEGORY 3</b><br><b>SE30 Ex - II 3 GD - NPN/PNP</b><br><b>(Article no. 552353)</b><br>Ex ec IIC T4 Gc<br>Ex tc IIIC T135 °C Dc IP6X<br>associated with sensor fittings made of PVDF, brass, stainless steel or aluminium | Not to be used   |  | Not to be used      |                     | to use with a 12...36 V supply source  |  |

### 6.3. Safety instructions - Notice of ATEX instructions

**Note:**

The appropriate Type SE30 Ex flowmeter variant depends on the installation environment.

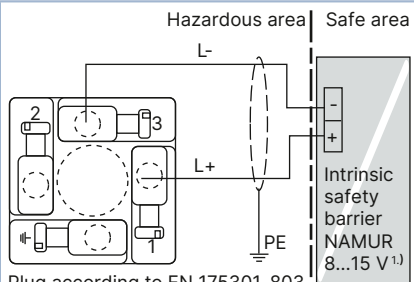
| Flowmeter Type SE30 Ex NAMUR (Article no. 552901) Group II - Category 1 for potentially explosive zones of gas (0, 1 and 2) and dust (20, 21 and 22)   |  |                        |  |           |        |           |         |           |          |           |          |           |     |
|--|--|------------------------|--|-----------|--------|-----------|---------|-----------|----------|-----------|----------|-----------|-----|
| <ul style="list-style-type: none"> <li><b>ATEX marking identification and ATEX installation zones</b></li> </ul> <p>CE 0102  II 1 GD Ex ia IIC T6<br/>                     Ex iaD 20 IP6X T80 °C<br/>                     ambient T: 0 °C ≤ Ta ≤ 60 °C</p> <p><b>LCIE 04 ATEX 6070 X</b></p> <ul style="list-style-type: none"> <li><b>Special conditions for a safe use</b></li> </ul> <p>The device is intrinsic safety certified and may be installed in potentially explosive atmospheres: zones 0, 1 or 2 and zones 20, 21 or 22.</p> <p>The connector can only be connected to certified intrinsic safety equipment. This combination must be compatible with intrinsic safety rules (see electrical safety data in the table under the adjacent connection diagram).</p> <p>The ambient temperature of use must always be between these limits: from 0...+ 60 °C.</p> <ul style="list-style-type: none"> <li>Compatible mechanical assembly and fluid connections:</li> </ul> <p> <b>Use only sensor fitting made of PVDF, brass, stainless steel or aluminium. Any other connection is prohibited.</b></p> |  <p>Plug according to EN 175301-803 of the SE30 Ex</p> <p>1.) Use an appropriate power supply which complies with the following electrical specifications</p> <p>Earth the shielding of the cable on side of the measuring exploitation</p> <table border="1"> <thead> <tr> <th colspan="2">Electrical safety data</th> </tr> </thead> <tbody> <tr> <td><b>Ui</b></td> <td>≤ 15 V</td> </tr> <tr> <td><b>Ii</b></td> <td>≤ 50 mA</td> </tr> <tr> <td><b>Pi</b></td> <td>≤ 188 mW</td> </tr> <tr> <td><b>Ci</b></td> <td>≤ 1.2 nF</td> </tr> <tr> <td><b>Li</b></td> <td>≈ 0</td> </tr> </tbody> </table> | Electrical safety data |  | <b>Ui</b> | ≤ 15 V | <b>Ii</b> | ≤ 50 mA | <b>Pi</b> | ≤ 188 mW | <b>Ci</b> | ≤ 1.2 nF | <b>Li</b> | ≈ 0 |
| Electrical safety data   |  |                        |  |           |        |           |         |           |          |           |          |           |     |
| <b>Ui</b>  | ≤ 15 V   |                        |  |           |        |           |         |           |          |           |          |           |     |
| <b>Ii</b>  | ≤ 50 mA  |                        |  |           |        |           |         |           |          |           |          |           |     |
| <b>Pi</b>  | ≤ 188 mW   |                        |  |           |        |           |         |           |          |           |          |           |     |
| <b>Ci</b>  | ≤ 1.2 nF   |                        |  |           |        |           |         |           |          |           |          |           |     |
| <b>Li</b>  | ≈ 0  |                        |  |           |        |           |         |           |          |           |          |           |     |

DTS 1000049988 EN Version: X Status: RL (released | freigegeben | validé) printed: 21.08.2024

**Flowmeter Type SE30 Ex NPN/PNP (Article no. 552353) Group II - Category 3 for potentially explosive zones of gas (2) and dust (22)**

• **ATEX marking identification and ATEX installation zones**

CE 0102 II 3 GD  
 Ex ec IIC T4 Gc  
 Ex tc IIIC T135 °C Dc IP6X  
 ambient T: 0 °C ≤ Ta ≤ 50 °C

• **Special conditions for a safe use**

The device is ATEX certified and may be installed in potentially explosive atmospheres: zones 2 or 22.

The connector may be connected to a 12...36 V supply source.

The ambient temperature of use must always be between these limits: from 0...+ 50 °C.

• Compatible mechanical assembly and fluid connections:

**Sensor fittings made of PVDF, brass, stainless steel, aluminium can be used. Any other connection is prohibited.**

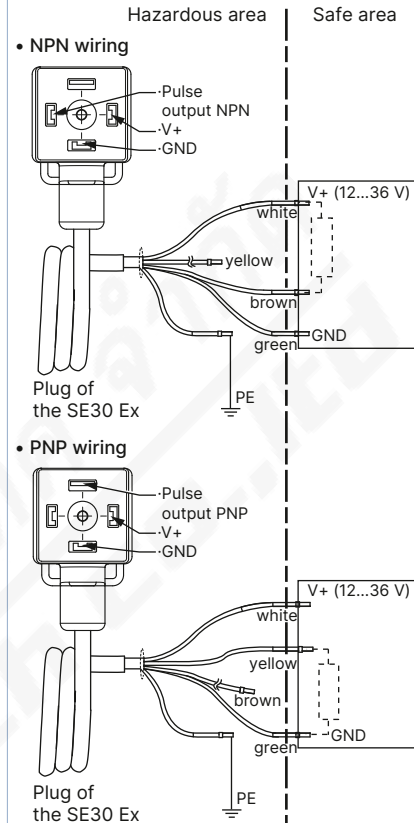

| Electrical safety data on power supply line (L+/L-) |        |
|---|--------|
| <b>U<sub>max.</sub></b>                             | 36 V   |
| <b>I<sub>max.</sub></b>                             | 30 mA  |
| <b>P<sub>max.</sub></b>                             | 108 mW |

DTS 1000049988 EN Version: X Status: RL (released | freigegeben | validé) printed: 21.08.2024

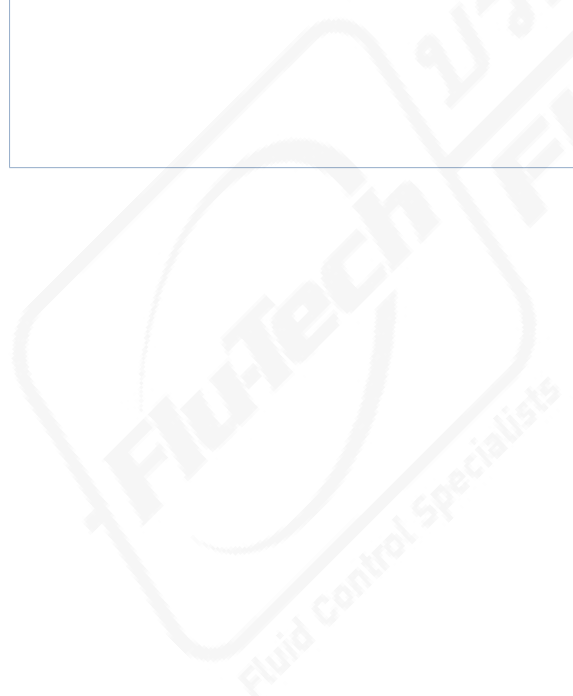

## 7. Product operation

### 7.1. Measuring principle

When liquid flows through the pipe, the paddle wheel with 4 inserted magnets or of the oval gear of the sensor-fitting Type S030 or Type S077 respectively is set in rotation, producing a measuring signal in the transmitter Type SE30 Ex.

- For the NAMUR variant, the electronic module modulates the current of the 2-wire supply line according to NAMUR standard. The modulated frequency of this signal is proportional to the flow rate. This signal is converted, by the connected type NAMUR intrinsic safety barrier, into a frequency signal on its open collector output.  
The electrical connection of the flowmeter is made via a cable plug (Type 2518 supplied, see **data sheet Type 2518** ▶).
- For the NPN/PNP variant, the generating signal, which frequency is proportional to the flow rate, can be displayed or processed directly. The electrical connection of the flowmeter is made via a cable plug with 5 or 12 m cable (Type 2513 not supplied, has to be ordered separately, see **data sheet Type 2513** ▶).

A K-factor (available in the **instruction manual of the Type S030 fitting** ▶ or **instruction manual of the Type S077 fitting** ▶) specific to each pipe (size and material) enables the conversion of this frequency into a flow rate/volume.

## 8. Product design and assembly

### 8.1. Product assembly

**Note:**

- A complete device to measure the flow rate is made up of an Inline sensor fitting Type S030 or Type S077 respectively with integrated paddle wheel or oval gear and a transmitter Type SE30 Ex.
- The Inline sensor-fitting Type S030 ensures simple installation into pipes from DN 06...DN 65. The transmitter Type SE30 Ex can easily be mounted on any Inline sensor fitting Type S030 and fastened with a bayonet catch.
- The Inline sensor-fitting Type S077 ensures simple installation into pipes from DN 15...DN 80. . The transmitter Type SE30 Ex can easily be mounted on any Inline sensor fitting Type S077 and fastened with a bayonet catch.

See **data sheet Type S030** ▶ or **data sheet Type S077** ▶ for more information.

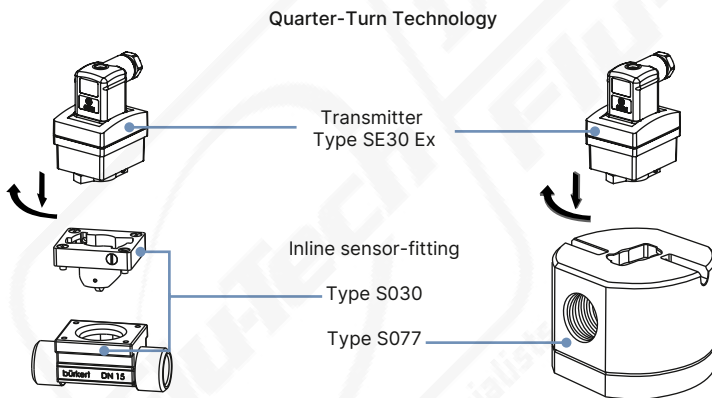

## 9. Product accessories

**Note:**

To operate this NAMUR signal, an intrinsically safe barrier must be connected to the flowmeter Type SE30 Ex.

### Description



- 2 or 4 channels, intrinsic safety digital inputs: proximity detectors NAMUR, contacts...
- Rail mount on hat profile 35 mm
- All connections by removable screw terminals

### Product properties

|                              |  |
|------------------------------|--|
| Dimensions                   | <ul style="list-style-type: none"> <li>• Housing for symmetrical DIN rail (hat profile 35 mm as per standard NFC63015 / EN50022)</li> <li>• Depth: 120 mm</li> <li>• Height: 90...145 mm overall including space for cables</li> <li>• Width on rail: 29.5 mm</li> <li>• Minimal distance between rails: 180 mm</li> </ul>   |
| Selection of the sensor type | Inductive or capacitive intrinsic safety certified NAMUR proximity detector or free-potential contacts   |
| Selection of the logic       | By a mini-DIP choice of active proximity switches or when contact is NO (Normally Open) or NC (Normally Closed)  |
| Fault detector               | <ul style="list-style-type: none"> <li>• For all inputs configured as NAMUR, all models are provided with fault detector (broken line or short-circuit)</li> <li>• In faulty case, the green front LED switches off, the contact of the defective channel opens and the red LED corresponding to the defective channel switches on</li> <li>• Other channels are not affected</li> </ul> |

### Electrical data

|                                    |  |
|------------------------------------|--|
| Operating voltage                  | <ul style="list-style-type: none"> <li>• 24 V DC ± 10 %</li> <li>• 230 V AC ± 10 %</li> <li>• 1 front panel yellow LED is "ON" when supply is active</li> </ul>  |
| Power consumption                  | 5 VA   |
| Digital input                      | Each of the 4 x intrinsic safety inputs can be configured independently for a contact or a proximity detector NAMUR as per DIN 19234   |
| Intrinsic safety input             | Proximity detector NAMUR as per DIN 19234 or free potential contacts, relays, pressure or temperature switches or push buttons in hazardous area   |
| Non intrinsic safety recopy output | <ul style="list-style-type: none"> <li>• According to the type of sensor and the chosen logic: a green LED on the front panel displays a free-potential contact for each channel without common wire.</li> <li>• Collector cut-off power: 15 V, 60 mA, 0.9 VA, 350 Hz</li> </ul> |

### Connections & communication

|                       |   |
|-----------------------|---|
| Electrical connection | All connections by removable screw terminals and supply distribution by means of a flat cable from one unit to the next one |
|-----------------------|---|

### Approvals and conformities

|                                    |  |
|------------------------------------|--|
| Classification for explosive areas | <ul style="list-style-type: none"> <li>• Intrinsic safety associated apparatus must be installed in safe area and connected to materials installed in zone 0, 1 or 2 - Gas (G) or in zone 20, 21 or 22 - Dust (D)</li> <li>• Classification according to 2014/34/EU ATEX directives:             <ul style="list-style-type: none"> <li>- <math>\text{Ex}</math> I/II (M1)/(1) G/D [Ex ia] IIC</li> <li>- Safety parameters see EC-type certificate LCIE 00ATEX 6034X</li> </ul> </li> </ul> |
|------------------------------------|--|

### Environment and installation

|                        |  |
|------------------------|--|
| Ambient temperature    | <ul style="list-style-type: none"> <li>• Operating: - 20...+ 60 °C, - 20...+ 50 °C (recommended)</li> <li>• Storage: - 40...+ 80 °C</li> </ul>   |
| Installation condition | <ul style="list-style-type: none"> <li>• Mounting on DIN rail:             <p>Must take into account thermal dissipation and risk of overheating generated by housings installed side by side. In case of a high concentration inherent safety barrier, we recommend to leave a free space of 10 mm between each group of 8 units (horizontal rail) and between each group of 4 units (vertical rail).</p> </li> <li>• Mounting inside a cabinet:             <p>It is recommended to close the electrical cabinet and to ensure a circulation of fresh air even by means of an air conditioner to keep the inside temperature at the level compatible with the recommended operating temperature among the units.</p> </li> </ul> |

DTS 1000049988 EN Version: X Status: RL (released | freigegeben | valide) printed: 21.08.2024

## 10. Networking and combination with other Bürkert products

### 10.1. Type SE30 Ex with marking II 1 G/D (NAMUR variant)

Example:

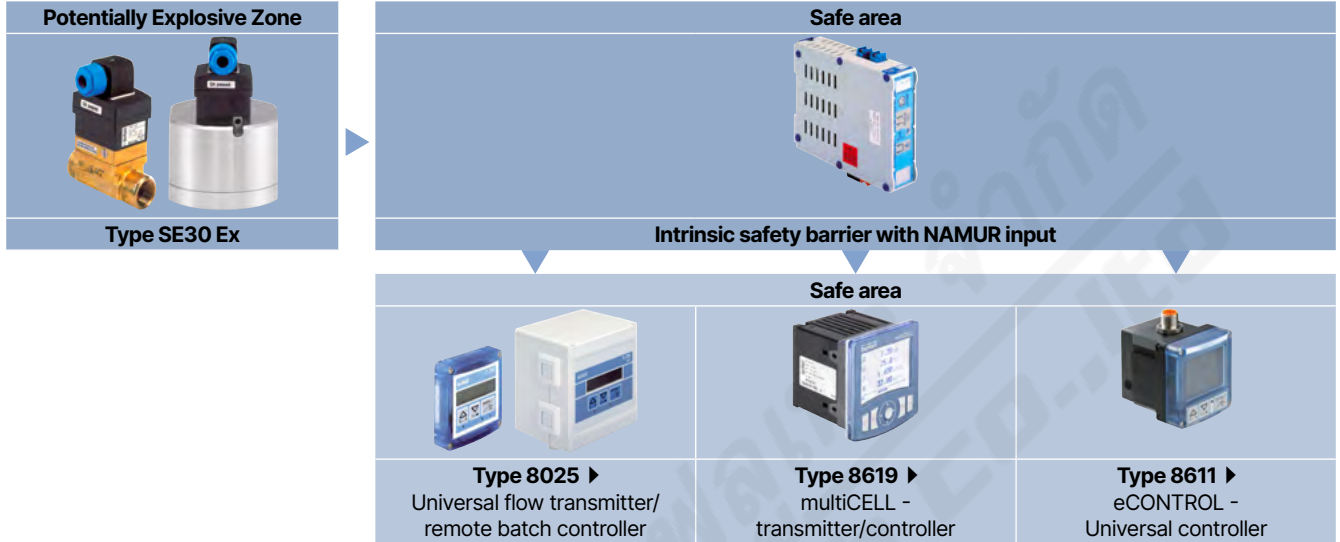

### 10.2. Type SE30 Ex with marking II 3 GD (NPN/PNP variant)

Example:

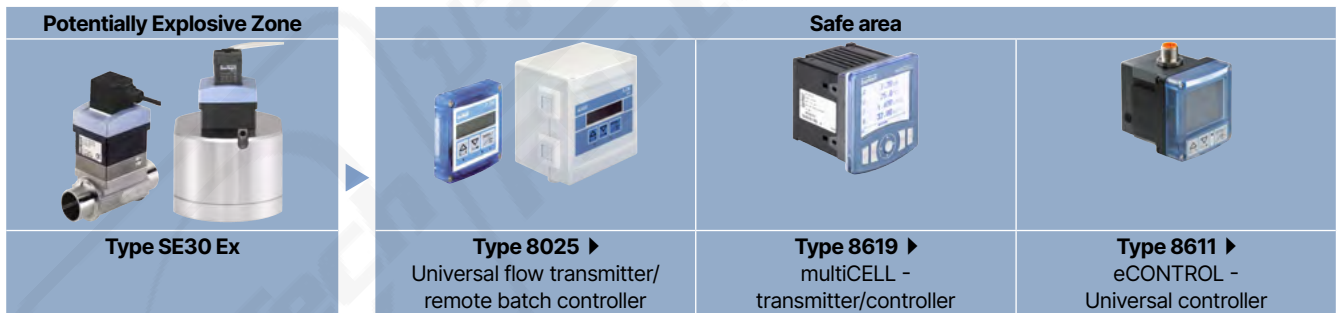

## 11. Ordering information

### 11.1. Bürkert eShop



#### Bürkert eShop – Easy ordering and quick delivery

You want to find your desired Bürkert product or spare part quickly and order directly? Our online shop is available for you 24/7. Sign up and enjoy all the benefits.

[Order online now](#)

### 11.2. Recommendation regarding product selection

A complete flowmeter for hazardous areas II 1 G/D - II 3 GD consists of a compact SE30 Ex flow transmitter and a Bürkert S030 or S077 Inline sensor-fitting.

Two different components must be ordered in order to select a complete device. The following information is required:

- **Article no.** of the desired compact SE30 Ex flow transmitter (see chapter **"11.4. Ordering chart"** on page 16).
- **Article no.** of the selected S030 or S077 Inline sensor-fitting (see **data sheet Type S030** ▶ or **data sheet Type S077** ▶)

### 11.3. Bürkert product filter

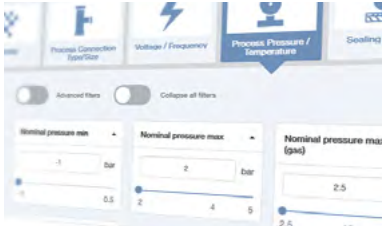

**Bürkert product filter – Get quickly to the right product**

You want to select products comfortably based on your technical requirements? Use the Bürkert product filter and find suitable articles for your application quickly and easily.

**Try out our product filter**

### 11.4. Ordering chart

| Description  | Operating voltage   | Output                           | Electrical connection    | Article no. |
|--|---|----------------------------------|--------------------------|-------------|
| SE30 Ex - NAMUR II 1 G/D for explosive gas and dust environments: zones 0, 1 or 2 and 20, 21 or 22 | 8...15 V DC, via an intrinsic safety barrier with NAMUR input <sup>1)</sup> | NAMUR current modulation, 2-wire | Cable plug EN 175301-803 | 552901      |
| SE30 Ex - II 3 GD for explosive gas and dust environments: zones 2 or 22                           | 12...36 V DC  | NPN/PNP                          |                          | 552353      |

1.) The open circuit voltage for the NAMUR input must be included between 8 and 15 V.

### 11.5. Ordering chart accessories

#### Cable plug

| Description  | Article no. |
|--|-------------|
| Female cable plug, 4-pin (3 conductors + protective conductor), form A according to DIN EN 175301-803 with cable gland and flat seal in silicone ( <b>Type 2518</b> ▶) <sup>1)</sup>         | 572330      |
| Female cable plug 28 mm, 4-pin (4 conductors + shielding), form A in accordance with DIN EN 175301-803, cable length: 5 m, NBR seal for NPN/PNP variant ( <b>Type 2513</b> ▶) <sup>2)</sup>  | 565558      |
| Female cable plug 28 mm, 4-pin (4 conductors + shielding), form A in accordance with DIN EN 175301-803, cable length: 12 m, NBR seal for NPN/PNP variant ( <b>Type 2513</b> ▶) <sup>2)</sup> | 565559      |

1.) For NAMUR variant

2.) The cable output is always oriented perpendicularly to the pipe.

#### Intrinsic safety barrier

| Classification of potentially explosive areas                 | Operating voltage | Outputs                     | Number of channels  | Article no. |
|---|-------------------|-----------------------------|---------------------|-------------|
| 2014/34/EU ATEX directives<br>⊕ I/II (M1)/(1) G/D [EE ia] IIC | 24 V DC           | Open collector, 15 V, 60 mA | 2, with NAMUR input | 553456      |
|   |                   |                             | 4, with NAMUR input | 553457      |
|   | 230 V AC          | Open collector, 15 V, 60 mA | 2, with NAMUR input | 553458      |
|   |                   |                             | 4, with NAMUR input | 553459      |