





AirLINE SP electropneumatic automation system

- Direct connection to the I/O system WAGO I/O System 750
- Innovative fieldbus interface
- Combination of fieldbus, pilot valves and I/O modules
- Compact design and high flexibility
- High flow rates

Product variants described in the data sheet may differ from the product presentation and description.

Can be combined with

- 

Type 2000 ▶
Pneumatically operated 2/2-way angle seat valve CLASSIC
- 

Type MKRS ▶
Redundancy valve block for safety related shut-off function
- 

Type 0498 ▶
Double pilot controlled check valve for realising 5/3-way function with all ports blocked
- 

Type 8614 ▶
Pneumatic control cabinet solutions for hygienic process environments

Type description

The AirLINE system represents a universal interface between process and system control. It integrates electric and pneumatic building blocks into an assembly, enabling a modular and flexible structure of fieldbus modules, pilot valves and I/O modules thanks to simple locking technology on the standard rail.

DTS 1000011132 EN Version: T Status: RL (released | freigegeben | validé) printed: 04.10.2023

FLU-TECH CO. LTD.

Email: sales@flutech.co.th **Website:** https://flutech.co.th

Tel: 02-384-6060, 086-369-5871-3 **Fax:** 02-384-5701 **LINE OA:** @flutech.co.th

Address (HQ): 845/3-4, Moo 3, Theparak Rd., T. Theparak, A. Mueang Samut Prakan, Samut Prakan, 10270, Thailand



Table of contents

1. General technical data	3
1.1. General data.....	3
1.2. Solenoid valves Type 6524 and Type 6525.....	5
1.3. Solenoid valves Type 0460	6
1.4. Solenoid valves Type 6526 and Type 6527	7
1.5. Solenoid valves Type 0461	8
1.6. AirLINE Quick.....	9
2. Product versions	10
2.1. Notes on compatibility and revision levels.....	10
2.2. Distinguishing features.....	10
Valve island	10
Module	10
Valves	11
3. Circuit functions	12
3.1. Standard functions.....	12
3.2. SIA variant.....	12
4. Approvals and conformities	13
4.1. General notes.....	13
4.2. Conformity	13
4.3. Standards.....	13
4.4. Explosion protection	13
4.5. North America (USA/Canada)	13
5. Materials	13
5.1. Bürkert resistApp	13
6. Dimensions	14
6.1. Type 8644 with valves Type 6524/6525	14
6.2. Type 8644 with single valve Type 6526/6527	15
7. Product design and assembly	16
7.1. Product assembly	16
AirLINE Quick adapterr	16
7.2. Example configuration	17
8. Ordering information	18
8.1. Bürkert eShop	18
8.2. Bürkert product filter.....	18
8.3. Ordering chart replacement valves	19
Solenoid valves Type 6524 and Type 6525.....	19
Solenoid valves Type 0460	20
Solenoid valves Type 0461	21
Solenoid valves Type 6526 and Type 6527	22
8.4. Ordering chart accessories.....	23
Cover plate.....	23
Blind plates AirLINE Quick.....	23
8.5. Ordering chart spare parts.....	24
Spare parts SVVI for Type 8644, REV1 – Pneumatics 11 mm width per station	24
Spare parts SVVI for Type 8644, REV1 – Pneumatics 16 mm width per station	25
Spare parts SVVI for Type 8644, REV2 – Pneumatics 11 mm width per station	26

1. General technical data

1.1. General data

Note:

Further information can be found in chapter:

- Type 6524, 6525 “1.2. Solenoid valves Type 6524 and Type 6525” on page 5
- Type 0460 “1.3. Solenoid valves Type 0460” on page 6
- Type 6526, 6527 “1.4. Solenoid valves Type 6526 and Type 6527” on page 7
- Type 0461 “1.5. Solenoid valves Type 0461” on page 8

Product properties	Type 0460, Type 6524, Type 6525	Type 0461, Type 6526, Type 6527
Dimensions	Further information can be found in chapter “6. Dimensions” on page 14.	
Material		
Body	PA (polyamide), aluminium (Type 0460)	PA (polyamide), aluminium (Type 0461)
Seal	FKM, NBR and PUR	NBR
Maximum installation width of a valve island	Further information can be found in chapter “6. Dimensions” on page 14.	
Width per station	11 mm	16.5 mm
Manual override	Standard	Standard
Number of valve positions	For single valves: max. 64 For impulse and double valves: max. 32	Max. 32 When using Type 0461: 24
Maximum number of valve functions	Max. 64	Max. 32
Switching function/Operating principle ¹⁾	Further information can be found in chapter “3. Circuit functions” on page 12.	
Pneumatic intermediate supply	Necessary for single valves after 24 valve functions. Necessary after 16 valve functions for double valves	Necessary after 16 valve functions
Performance data		
Pressure data	Overpressure to atmospheric pressure	Overpressure to atmospheric pressure
Pressure range	Vac....10 bar	Vac....10 bar
External supply air (auxiliary pilot air)	>2.5 bar (Type 0460: not possible)	>2.5 bar (Type 0461: not possible)
Flow rate Q_{Nn} value air	300 l/min measured at +20 °C, 6 bar pressure at valve inlet and 1 bar differential pressure	700 l/min measured at +20 °C, 6 bar pressure at valve inlet and 1 bar differential pressure
Flow rate Q_{Nn} value air with integrated P shut-off	Flow reduced by approx. 25 %	N/A
Nominal operating mode	Continuous operation (100 % duty cycle)	Continuous operation (100 % duty cycle)
Switching time	Measured according to ISO 12238	Measured according to ISO 12238
Electrical data		
Operating voltage	24 V DC	24 V DC
Voltage tolerance	+20 %/- 15 % (when using Type 0460: ± 10 %)	+20 %/- 15 % (when using Type 0461: ± 10 %)
Residual ripple (at DC)	1 Vss	1 Vss
Nominal power of each valve	With single valves: 0.8 W For impulse and double valves: 2x 0.8 W	2 W, 1 W
Nominal current of each valve	43 mA (28 mA holding current after 120 ms) 41 mA (when using Type 0460)	85 mA (52 mA holding current after 120 ms) 41 mA (when using Type 0461)
Position feedback	Via cooperation partners	Via cooperation partners
Protection class	III according to VDE 106, IEC 60536	III according to VDE 106, IEC 60536
With fieldbus connection	See operating instructions Type 8644 ▶	
Medium data		
Operating medium	Oil-free or lubricated compressed dry air (5 µm filter recommended)	Oil-free or lubricated compressed dry air (5 µm filter recommended)
Compressed air quality	ISO 8573-1:2010, Class 7.4.4	ISO 8573-1:2010, Class 7.4.4
Approvals and conformities		
Degree of protection	IP20 IP65 in closed control cabinet	IP20 IP65 in closed control cabinet
Explosion protection	Further information can be found in chapter “4.4. Explosion protection” on page 13.	
North America (USA/Canada)	Further information can be found in chapter “4.5. North America (USA/Canada)” on page 13.	

Process/Port connection & communication		
Working connection	D 4, D 6, D ¼, D 8, NPT ⅛, G ⅛	D 8, NPT ⅜, G ⅛
Air supply connection	G ¼, NPT ¼, D 10, G ⅜, NPT ⅜	G ⅜, NPT ⅜
Communication module	WAGO I/O System 750	WAGO I/O System 750
Communication interface	PROFIBUS DP, INTERBUS, DeviceNet, CANopen, Ethernet. Others on request	PROFIBUS DP, INTERBUS, DeviceNet, CANopen, Ethernet. Others on request
Environment and installation		
Installation position	As required, preferably with actuator upright	As required, preferably with actuator upright
Storage temperature	-20...+60 °C	-20...+60 °C
Ambient temperature	0...+55 °C (when using Type 0460: 0 °C...+50 °C)	0...+55 °C (when using Type 0461: 0 °C...+50 °C)

1.) The maximum flow rate depends on the valve function.

1.2. Solenoid valves Type 6524 and Type 6525



- The pilot valves **Type 6524** (single and double valve) and **Type 6525** (single valve) consist of a pilot flipper solenoid valve Type 6144 and a pneumatic seat valve.
- The operating principle allows switching of high pressures with low power consumption and short switching times.
- The pilot valves are equipped with a manual override as standard.
- The pneumatic flange pattern of the pilot valves Type 6524 and 6525 (single valves) for Type 8644 REV2 has been standardised. There is a difference to the flange pattern of the pilot valves for Type 8644 REV1. It is therefore imperative to take into account the different article numbers of the pilot valves as described in chapter **“8.3. Ordering chart replacement valves” on page 19.**
- Further information about ordering information can be found in chapter **“8.3. Ordering chart replacement valves” on page 19.**
- Further information about further valve options can be found in chapter **“8.4. Ordering chart accessories” on page 23.**

Pilot valve Type	Type 6524, Type 6525	Type 6524
Circuit function	3/2 and 5/2-way valve	2 x 3/2-way valve
Product properties		
Materials		
Body	PA (polyamide)	
Seal	FKM, NBR and PUR	
Width per station	11 mm	
Manual override	Standard	
Pneumatic module	With plug-in coupling, Ø 6 mm, Ø ¼"	
Performance data		
Pressure data	Overpressure to atmospheric pressure	
Flow rate Q _{Nn} value air	Measured at +20 °C, 6 bar pressure at valve inlet and 1 bar differential pressure, see “8.3. Ordering chart replacement valves” on page 19.	
Duty cycle	Continuous operation (100 % duty cycle)	
Switching time	Measured according to ISO 12238	
Electrical data		
Operating voltage	24 V DC (10 % residual ripple permissible)	
Nominal power of each valve	0.8 W	2 x 0.8 W with reduction of power
Medium data		
Operating medium	Oil-free or lubricated compressed dry air, neutral gases (5 µm filter recommended)	
Process/Port connection & communication		
Service port 2 (A), 4 (B)	Plug-in coupling Ø 6 mm, Ø ¼"	
Air supply connection 1 (P), 3 (R), 5 (S)	G ¼	
Electrical connection (on valve)	Rectangular plug, 2-pin, grid spacing 5.08 mm Cable with strands ^{1.)}	Rectangular plug, 3-pin, grid spacing 2.54 mm Cable with strands ^{1.)}
Environment and installation		
Installation position	As required, preferably with actuator upright	
Mounting condition	With 2 screws M2 x 20	With 2 screws M2 x 28

1.) Versions with safety-related shutdown. The switching contact must be located in the same control cabinet as the valve block. The line length must be limited to a maximum of 2 m.

DTS 1000011132 EN Version: T Status: RL (released | freigegeben | valide) printed: 04.10.2023

1.3. Solenoid valves Type 0460



- The solenoid valve **Type 0460** consists of a pneumatic valve body fitted with a double coil pilot valve.
- The principle allows switching of high pressures together with low power consumption and fast switching times.
- All valves are equipped with manual override as a standard.
- Further information about ordering information can be found in chapter **“Solenoid valves Type 0460” on page 20.**
- Further information about further valve options can be found in chapter **“8.4. Ordering chart accessories” on page 23.**

Pilot valve Type	Type 0460
Circuit function	5/2-way and 5/3-way bistable
Product properties	
Materials	
Body	Aluminium
Seal	NBR
Width per station	11 mm
Manual override	Standard
Pneumatic module	With plug-in coupling, Ø 6 mm, Ø ¼"
Performance data	
Pressure data	Overpressure to atmospheric pressure
Flow rate Q _{Nn} value air	300 l/min measured at +20 °C, 6 bar pressure at valve inlet and 1 bar differential pressure, see “8.3. Ordering chart replacement valves” on page 19.
Switching time	Measured according to ISO 12238
Electrical data	
Operating voltage	24 V DC ± 10 %
Medium data	
Operating medium	Oil-free or lubricated compressed dry air, neutral gases (5 µm filter recommended)
Process/Port connection & communication	
Service port 2 (A), 4 (B)	Plug-in coupling Ø 6 mm, Ø ¼"
Air supply connection 1 (P), 3 (R), 5 (S)	G ¼
Electrical connection (on valve)	Rectangular plug, 3-pin, grid 2.54 mm
Environment and installation	
Installation position	As required, preferably with actuator upright
Mounting condition	With 2 screws M1.7 × 23

DTS 1000011132 EN Version: T Status: RL (released | freigegeben | validé) printed: 04.10.2023

1.4. Solenoid valves Type 6526 and Type 6527



- The solenoid valves **Type 6526** ▶ and **Type 6527** ▶ consist of a pneumatic valve body fitted with a **Type 6106** ▶ rocker solenoid valve.
- The operating principle allows high pressures to be switched with low power consumption and short switching times.
- The solenoid valves are equipped with manual override as a standard.
- Further information about ordering information can be found in chapter “**Solenoid valves Type 6526 and Type 6527**” on page 22.
- Further information about further valve options can be found in chapter “**8.4. Ordering chart accessories**” on page 23.

Pilot valve Type	Type 6526	Type 6527
Circuit function	3/2-way valve	5/2-way valve
Product properties		
Material		
Body	PA (polyamide)	
Seal	NBR	
Width per station	16.5 mm	
Manual override	Standard	
Pneumatic modules	With plug-in coupling, Ø 8 mm	
Performance data		
Pressure data	Overpressure to atmospheric pressure	
Flow Q_{Nn} value air	300 l/min measured at +20 °C, 6 bar pressure at valve inlet and 1 bar differential pressure, see “ 8.3. Ordering chart replacement valves ” on page 19.	
Nominal operating mode	Continuous operation (100 % duty cycle)	
Switching time	Measured according to ISO 12238	
Electrical data		
Operating voltage	24 V DC ± 10 %	
Electrical connection (on valve)	Plug contact according to DIN EN 175301 - 803 (previously DIN 43650) form C	
Nominal power of each valve	2 W, 1 W	
Medium data		
Medium	Oil-free or lubricated compressed dry air, neutral gases (5 µm filter recommended)	
Process/Port connection & communication		
Service port 2 (A), 4 (B)	Plug-in coupling, Ø 8 mm	
Air supply connection 1 (P), 3 (R), 5 (S)	G ½	
Environment and installation		
Installation position	As required, preferably with solenoid valve upright	
Mounting condition	With 2 screws M3 x 30	

1.5. Solenoid valves Type 0461



- The solenoid valves **Type 0461** ▶ consist of a pilot flipper solenoid valve with double coil and a pneumatic slide valve.
- The operating principle allows high pressures to be switched with low power consumption and short switching times.
- All valves are equipped with manual override as standard.
- Further information about ordering information can be found in chapter **“Solenoid valves Type 0461” on page 21.**
- Further information about further valve options can be found in chapter **“8.4. Ordering chart accessories” on page 23.**

Pilot valve Type	Type 0461
Circuit function	5/2-way pulse and 5/3-way
Product properties	
Material	
Body	Aluminium
Seal	NBR
Width per station	16.5 mm
Manual override	Standard
Pneumatic modules	With plug-in coupling, Ø 8 mm
Performance data	
Pressure data	Overpressure to atmospheric pressure
Flow Q _{Nn} value air	Measured at +20 °C, 6 bar pressure at valve inlet and 1 bar differential pressure, see “8.3. Ordering chart replacement valves” on page 19.
Switching time	Measured according to ISO 12238
Electrical data	
Operating voltage	24 V DC ± 10 %
Electrical connection (on valve)	Rectangular plug, 3-pin, pitch 2.54 mm
Medium data	
Operating medium	Oil-free or lubricated compressed dry air, neutral gases (5 µm filter recommended)
Process/Port connection & communication	
Port connection	Flange

DTS 1000011132 EN Version: T Status: RL (released | freigegeben | validé) printed: 04.10.2023

1.6. AirLINE Quick

Note:

The valves of Type 0460 valves cannot be installed with AirLINE Quick due to their size.

AirLINE Quick considerably reduces the use of components in the control cabinet. With the AirLINE Quick Adapter, the valve terminal is adapted directly to the control cabinet floor or control cabinet wall.

Advantages:

- Reduced space requirement in the control cabinet
- This makes it possible to use more compact control cabinets
- Reduced installation effort due to hose connections directly at the bottom of the control cabinet

Product properties

Material	
AirLINE Quick Adapter	Stainless steel 1.4301 Anodised aluminium
Pneumatic connection	Stainless steel 1.4301 Nickel-plated brass
Valve positions	4, 8, 12, 16, 24
Valve functions	Up to 48

Process/Port connection & communication

Connections	
Pneumatic feeding	G ¼, D ⅜"
Pneumatic service ports	Plug-in coupling Ø 6 mm, Ø ¼"

Environment and installation

Installation position	Control cabinet wall Control cabinet floor
-----------------------	---

AirLINE Quick Adapter in stainless steel 1.4301 or anodised aluminium

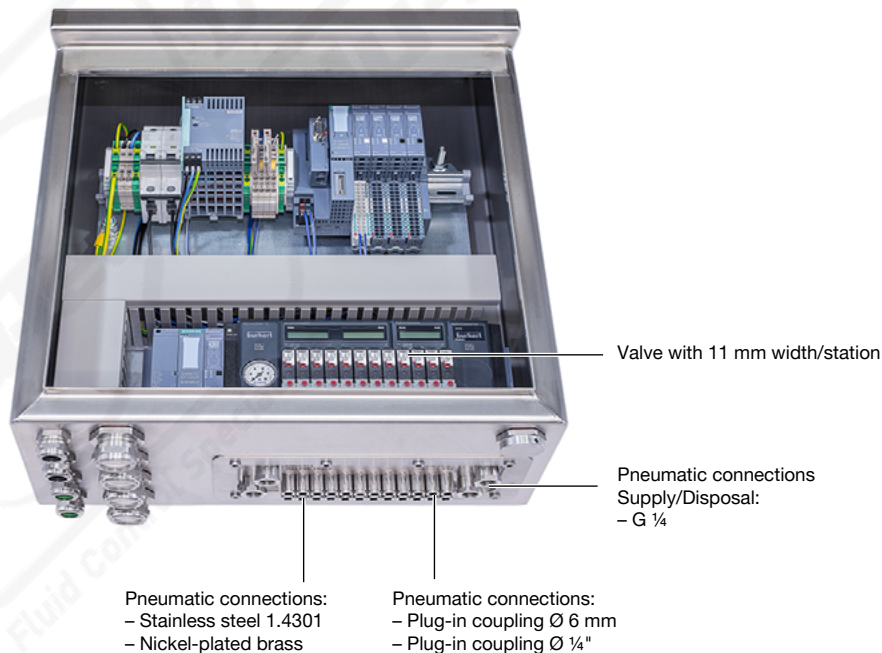

DTS 1000011132 EN Version: T Status: RL (released | freigegeben | valide) printed: 04.10.2023

2. Product versions

2.1. Notes on compatibility and revision levels

The single valves Type 6524 and Type 6525, the pneumatic basic and connection modules and as well as the control cabinet base adaptation AirLINE Quick have been optimised.

2.2. Distinguishing features

Valve island

Revision island	Type 8644 REV1 ^{1.)}	Type 8644 REV2 ^{1.)}
Visual distinction		
Marking on type plate		

1.) If you have any questions regarding the differences in revisions, please contact your Bürkert sales department.

Module

Revision island	Type 8644 REV1 ^{1.)}	Type 8644 REV2 ^{1.)}
Channel arrangement of the working connections	Parallel 	Wavy
Colour of the release rings (hose connector)	Black	Blue
Flow reduction with integrated P shut-off	Up to 50 %	Up to 20 %

1.) If you have any questions regarding the differences in revisions, please contact your Bürkert sales department.

DTS 1000011132 EN Version: T Status: RL (released | freigegeben | valide) printed: 04.10.2023

Valves

Valves Type 6524, Type 6525	Valve REV1	Valve REV2
Visual distinction		
Article no.	Distinction by Article no., see "8.3. Ordering chart replacement valves" on page 19	
Information label	There is an information label on the valve which indicates that the valve has been overhauled. This information label must be removed before assembly.	

Further information can be found in the **operating instructions Type 8644** ►.

DTS 1000011132 EN Version: T Status: RL (released | freigegeben | valide) printed: 04.10.2023



3. Circuit functions

3.1. Standard functions

Symbol	Description
	Circuit function C (CF C) 3/2-way solenoid valve Servo-controlled, with manual override Normally closed
	Circuit function C (CF C) 2 x 3/2-way solenoid valve Servo-controlled, with manual override Normally closed
	Circuit function D (CF D) 3/2-way solenoid valve Servo-controlled, with manual override Normally open
	Circuit function H (CF H) 5/2-way solenoid valve Servo-controlled, with manual override Pressure applied via port (1), therefore one of the two ports (2) or (4) is under pressure.
	Circuit function L (CF L) 5/3-way solenoid valve With manual override In middle position all ports locked
	Circuit function N (CF N) 5/3-way solenoid valve With manual override In middle position ports 2 and 4 exhausted
	Circuit function Z (CF Z) 5/2-way solenoid valve Impulse version with 2 coils and manual override Pressure applied via port (1), therefore one of the two ports (2) or (4) is under pressure.

3.2. SIA variant

Symbol	Description
	Circuit function C (CF C) 3/2-way solenoid valve Servo-controlled Normally closed
	Circuit function C (CF C) 2 x 3/2-way solenoid valve Servo-controlled Normally closed
	Circuit function D (CF D) 3/2-way solenoid valve Servo-controlled Normally open
	Circuit function G (CF G) 4/2-way solenoid valve Servo-controlled

DTS 1000011132 EN Version: T Status: RL (released | freigegeben | validé) printed: 04.10.2023

4. Approvals and conformities

4.1. General notes

- The approvals and conformities listed below must be stated when making enquiries. This is the only way to ensure that the product complies with all required specifications.
- Not all available versions can be supplied with the below mentioned approvals or conformities.



4.2. Conformity

In accordance with the Declaration of conformity, the product is compliant with the EU Directives.

4.3. Standards

The applied standards which are used to demonstrate compliance with the EU Directives are listed in the EU-Type Examination Certificate and/or the EU Declaration of Conformity.

4.4. Explosion protection

Approval	Description
 	<p>Optional: Explosion protection As a category 3 device suitable for zone 2 (optional).</p> <p>ATEX: PTB 15 ATEX 2001 X II 3G Ex ec IIC T4 Gc</p> <p>IECEx: IECEx PTB 16.0014 X Ex ec IIC T4 Gc</p>

4.5. North America (USA/Canada)

Approval	Description
	<p>Optional: UL Listed for the USA and Canada The products are UL Listed for the USA and Canada according to:</p> <ul style="list-style-type: none"> • UL 61010-1 (ELECTRICAL EQUIPMENT FOR MEASUREMENT, CONTROL, AND LABORATORY USE – Part 1: General Requirements) • CAN/CSA-C22.2 No. 61010-1

5. Materials

5.1. Bürkert resistApp



Bürkert resistApp – Chemical resistance chart

You want to ensure the reliability and durability of the materials in your individual application case? Verify your combination of media and materials on our website or in our resistApp.

[Start chemical resistance check](#)

DTS 1000011132 EN Version: T Status: RL (released | freigegeben | validé) printed: 04.10.2023

6. Dimensions

6.1. Type 8644 with valves Type 6524/6525

Note:

- 11 mm width per station
- Dimensions in mm, unless otherwise stated
- n = number of valves

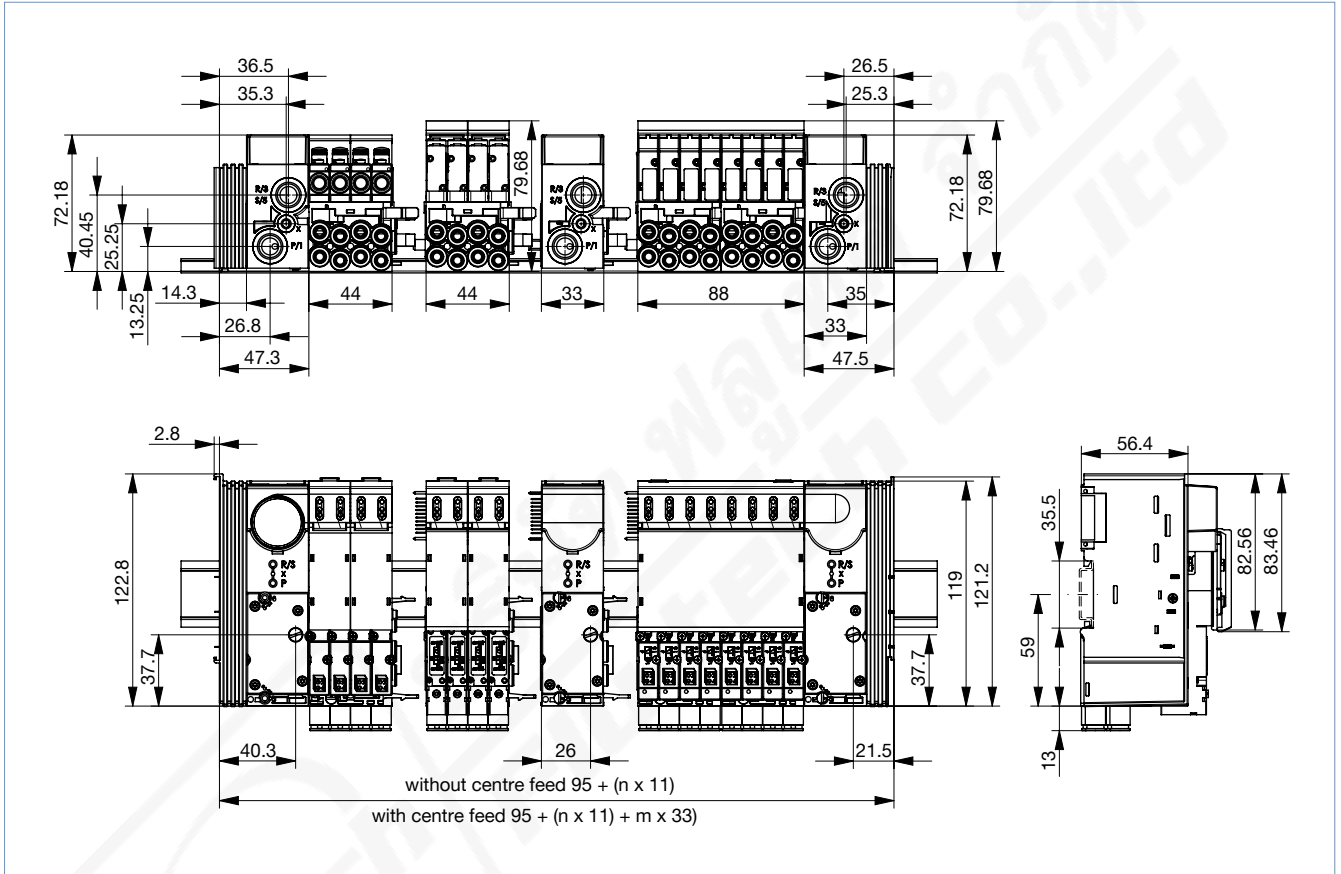

6.2. Type 8644 with single valve Type 6526/6527

Note:

- 16.5 mm width per station
- Dimensions in mm, unless otherwise stated
- n = number of valves

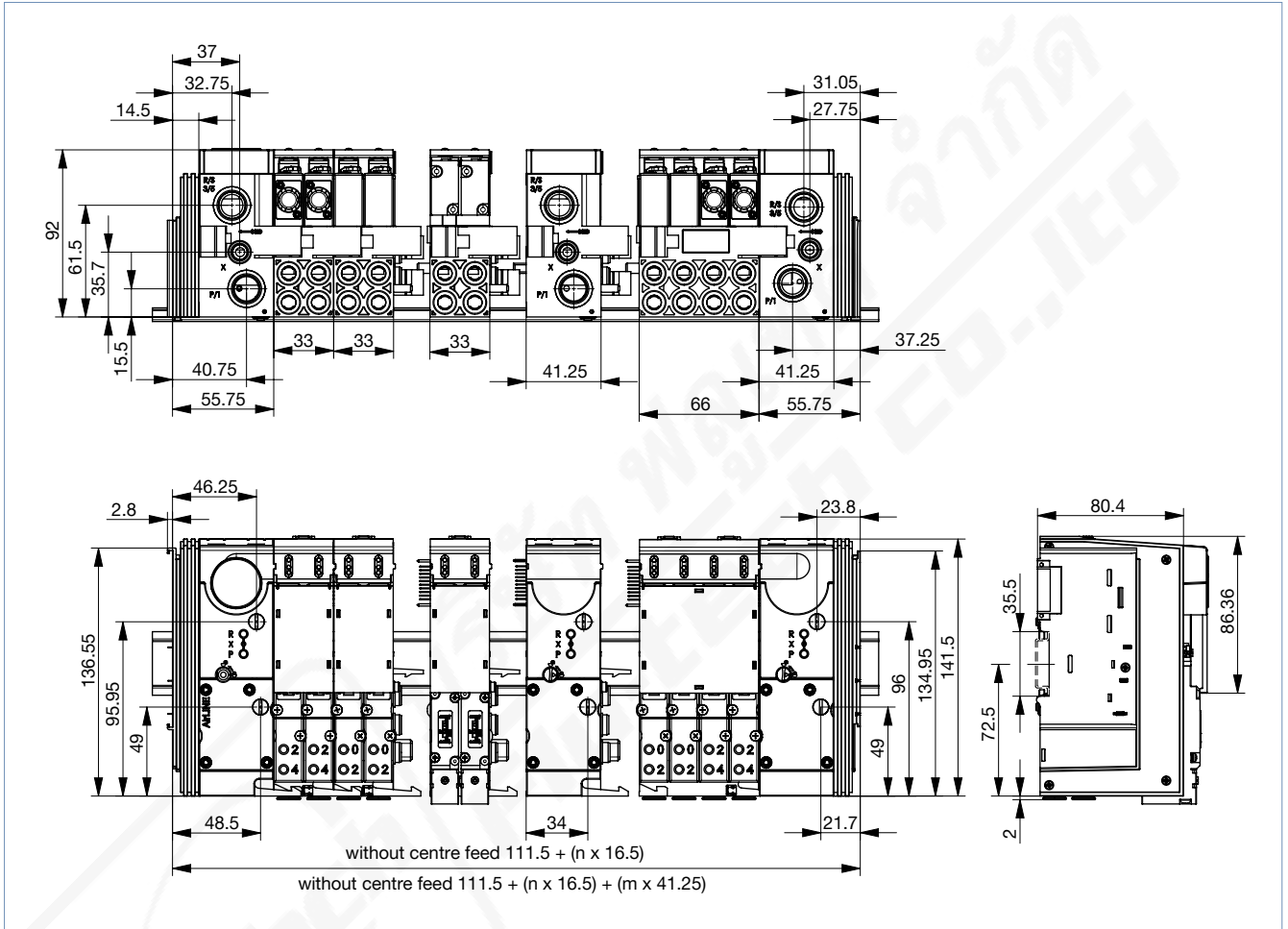

DTS 1000011132 EN Version: T Status: RL (released | freigegeben | validé) printed: 04.10.2023

7. Product design and assembly

7.1. Product assembly

AirLINE Quick adapterr

AirLINE Quick considerably reduces the use of components in the control cabinet. With the AirLINE Quick Adapter, the valve island is directly adapted on the control cabinet floor or wall.

Note:

Type 0460 valves cannot be installed with AirLINE Quick because of their size.

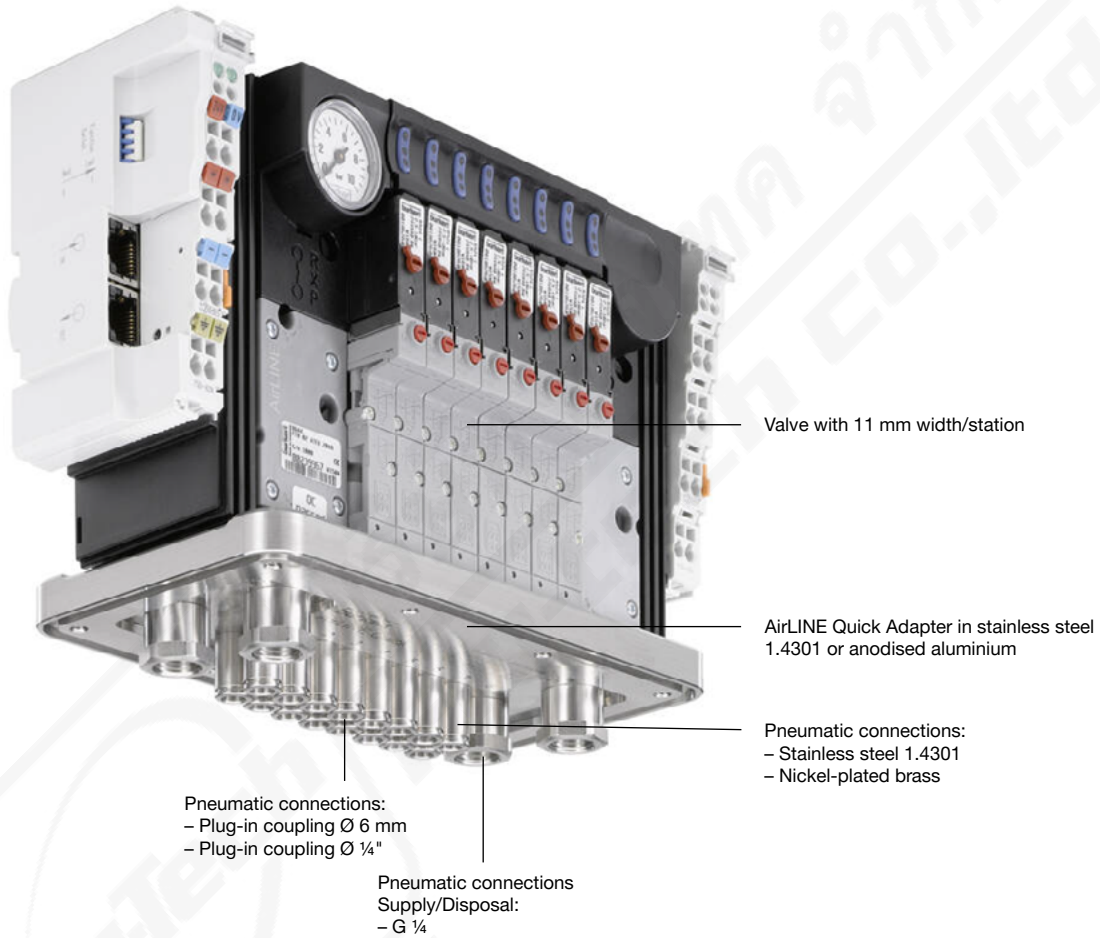

DTS 1000011132 EN Version: T Status: RL (released | freigegeben | validé) printed: 04.10.2023

7.2. Example configuration

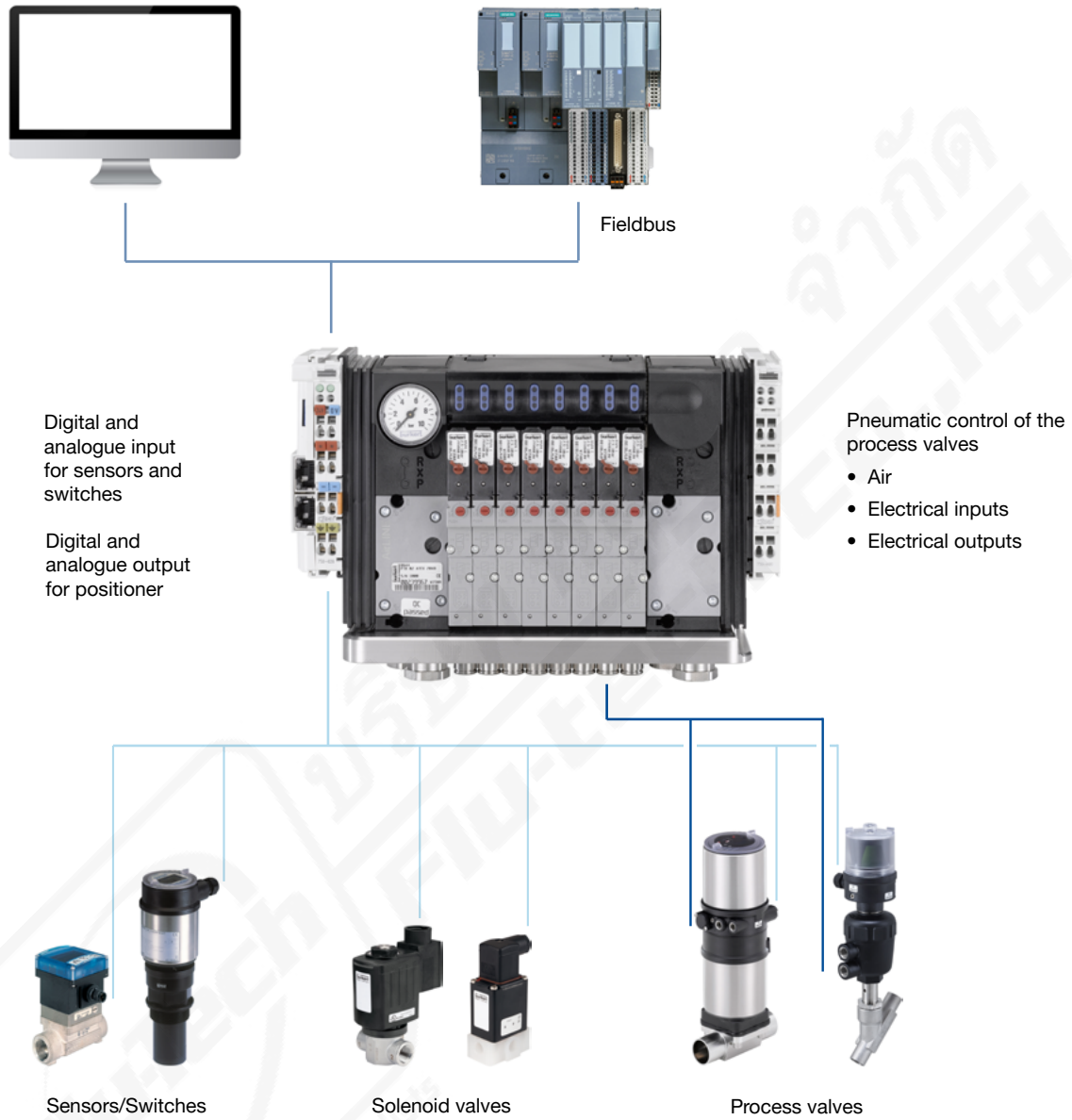

DTS 1000011132 EN Version: T Status: RL (released | freigegeben | validé) printed: 04.10.2023

8. Ordering information

8.1. Bürkert eShop



Bürkert eShop – Easy ordering and quick delivery

You want to find your desired Bürkert product or spare part quickly and order directly? Our online shop is available for you 24/7. Sign up and enjoy all the benefits.

[Order online now](#)

8.2. Bürkert product filter



Bürkert product filter – Get quickly to the right product

You want to select products comfortably based on your technical requirements? Use the Bürkert product filter and find suitable articles for your application quickly and easily.

[Try out our product filter](#)

DTS 1000011132 EN Version: T Status: RL (released | freigegeben | validé) printed: 04.10.2023



8.3. Ordering chart replacement valves

Solenoid valves Type 6524 and Type 6525

Note:

Further information about this product version can be found in chapter “1.2. Solenoid valves Type 6524 and Type 6525” on page 5.

Circuit function	Orifice [mm]	Q _{Nn} value air ^{1.)} [l/min]	Pressure range [bar]	Switching times		Voltage/ Frequency [V/Hz]	Article no.	
				Opening [ms]	Closing [ms]		Valves for 8647 REV1	Valves for 8647 REV2 ^{3.)}
C (CF C) 3/2-way solenoid valve Servo-controlled, with manual override Normally closed 	4.0	300	Vac....7	15	20	24 V DC	20029915 ☞ (186258 ☞ ^{4.)}	20029923 ☞ (20013119 ☞ ^{4.)}
			1...10 ^{2.)}	15	20	24 V DC	20029913 ☞ (186257 ☞ ^{4.)}	20029921 ☞ (20013114 ☞ ^{4.)}
			2.5...10	15	28	24 V DC	20029910 ☞ (184043 ☞ ^{4.)}	20029918 ☞ (365606 ☞ ^{4.)}
D (CF D) 3/2-way solenoid valve Servo-controlled, with manual override Normally open 	4.0	300	2.5...10	15	28	24 V DC	20029911 ☞ (184400 ☞ ^{4.)}	20029919 ☞ (365609 ☞ ^{4.)}
H (CF H) 5/2-way solenoid valve Servo-controlled, with manual override Pressure applied via port (1), therefore one of the two ports (2) or (4) is under pressure. 	4.0	300	1...10 ^{2.)}	15	20	24 V DC	20029914 ☞ (186271 ☞ ^{4.)}	20029922 ☞ (20013117 ☞ ^{4.)}
			2.5...10	20	28	24 V DC	20029912 ☞ (179938 ☞ ^{4.)}	20029920 ☞ (365610 ☞ ^{4.)}
C (CF C) 2 x 3/2-way solenoid valve Servo-controlled, with manual override Normally closed 	4.0	300	1...10 ^{2.)}	12	20	24 V DC	186259 ☞	
			2.5...10	12	20	24 V DC	186260 ☞	

- 1.) With integrated Hot Swap and/or non-return function, see chapter “2.2. Distinguishing features” on page 10.
- 2.) Version with auxiliary pilot air
- 3.) If you have any questions about the compatibility of the valve revision, please contact your Bürkert sales office.
- 4.) The Article no. can no longer be ordered. Order the superordinate set instead.

DTS 1000011132 EN Version: T Status: RL (released | freigegeben | validé) printed: 04.10.2023

Solenoid valves Type 0460

Note:

Further information about this product version can be found in chapter “1.3. Solenoid valves Type 0460” on page 6.

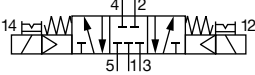
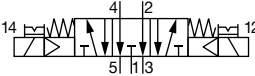
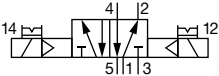
Circuit function	Orifice [mm]	Q _{Nn} value air ^{1.)} [l/min]	Pressure range ^{2.)} [bar]	Switching times		Nominal power [W]	Article no. Valve for 8647 REV1 & 2
				Opening [ms]	Closing [ms]		
L (CF L) 5/3-way solenoid valve With manual override In middle position all ports locked 	2.5	200	2.0...7.0	15	20	1	154184 ☞
N (CF N) 5/3-way solenoid valve With manual override In middle position ports 2 and 4 exhausted 	2.5	200	2.0...7.0	15	20	1	154185 ☞
Z (CF Z) 5/2-way solenoid valve Impulse version with 2 coils and manual override Pressure applied via port (1), therefore one of the two ports (2) or (4) is under pressure. 	2.5	200	2.0...7.0	15	15	0.5	154183 ☞

1.) Measurement at +20 °C, 6 bar pressure at valve inlet and 1 bar differential pressure
 2.) Pressure information: overpressure to atmospheric pressure

DTS 1000011132 EN Version: T Status: RL (released | freigegeben | validé) printed: 04.10.2023

Solenoid valves Type 0461

Note:

Further information about this product version can be found in chapter “1.5. Solenoid valves Type 0461” on page 8.

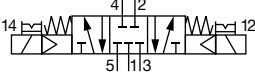
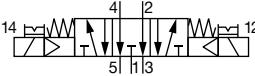
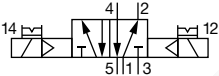
Circuit function	Orifice [mm]	Q _{Nn} value air [l/min]	Pressure range [bar]	Switching times		Nominal power [W]	Article no. Valve for 8647 REV1 & 2
				Opening [ms]	Closing [ms]		
L (CF L) 5/3-way solenoid valve With manual override In middle position all ports locked 	6	500	2.5...7	15	50	1	156767
N (CF N) 5/3-way solenoid valve With manual override In middle position ports 2 and 4 exhausted 	6	500	2.5...7	15	50	1	156768
Z (CF Z) 5/2-way solenoid valve Impulse version with 2 coils and manual override Pressure applied via port (1), therefore one of the two ports (2) or (4) is under pressure. 	6	500	2.5...7	20	30	1	156766

DTS 1000011132 EN Version: T Status: RL (released | freigegeben | validé) printed: 04.10.2023

Solenoid valves Type 6526 and Type 6527

Note:

Further information about this product version can be found in chapter “1.4. Solenoid valves Type 6526 and Type 6527” on page 7.

Circuit function	Orifice [mm]	Q _{Nn} value ^{1.)} air [l/min]	Pressure range ^{2.)} [bar]	Switching times		Nominal power [W]	Voltage/ Frequency [V/Hz]	Article no. Valve for 8647 REV1 & 2
				Opening [ms]	Closing [ms]			
C (CF C) 3/2-way solenoid valve Servo-controlled, with manual override Normally closed 	6	700	1.0...10 ^{1.)}	20	12	2	24 V DC	156842
			1.0...10 ^{1.)}	20	12	2	24 V DC	163028
			2.0...10	20	12	2	24 V DC	156318
			2.0...10	20	12	2	24 V DC	158944
			2.0...8.0	20	17	1	24 V DC	156840
			2.0...8.0	20	12	1	24 V DC	158947
D (CF D) 3/2-way solenoid valve Servo-controlled, with manual override Normally open 	4.0	300	2.0...10	12	20	2	24 V DC	156320
			2.0...10	20	12	2	24 V DC	158946
			2.0...8.0	17	20	1	24 V DC	156841
H (CF H) 5/2-way solenoid valve Servo-controlled, with manual override Pressure applied via port (1), therefore one of the two ports (2) or (4) is under pressure. 	6	700	1.0...10 ^{1.)}	20	12	2	24 V DC	156828
			1.0...10 ^{1.)}	20	12	2	24 V DC	163030
			2.0...10	20	12	2	24 V DC	156337
			2.0...10	20	12	2	24 V DC	158942
			2.0...8.0	20	17	1	24 V DC	156827
			2.0...8.0	20	12	1	24 V DC	158943

1.) Measurement at +20 °C, 6 bar pressure at valve inlet and 1 bar differential pressure
 2.) Pressure information: overpressure to atmospheric pressure

DTS 1000011132 EN Version: T Status: RL (released | freigegeben | valide) printed: 04.10.2023

8.4. Ordering chart accessories

Cover plate

Note:

If not all the valve connections in a basic valve unit module are used, then these connections should be covered by the appropriate cover plate to ensure full efficiency.

Cover plate	Article no.
Cover plate for solenoid valves Type 6524/6525 (REV1)	650373
Cover plate for solenoid valves Type 6524/6525 (REV2)	661092
Cover plate for solenoid valves Type 6524 2x 3/2-way valve	661092
Cover plate for solenoid valves Type 0460	655069
Cover plate for solenoid valves Type 6526/6527	653765
Cover plate for solenoid valves Type 0461	657490

Blind plates AirLINE Quick

Note:

A blind plate is used to cover an existing flange for AirLINE Quick on the cabinet wall or on the cabinet floor.

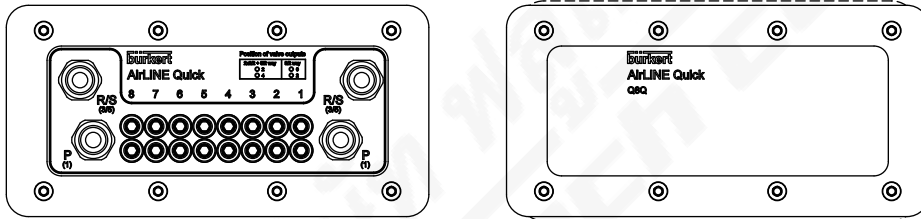

Description	Article no.
Blind plate AirLINE Quick, 4-fold	20057391
Blind plate AirLINE Quick, 8-fold	20057390
Blind plate AirLINE Quick, 12-fold	20057388
Blind plate AirLINE Quick, 16-fold	20057387
Blind plate AirLINE Quick (valve terminal with intermediate supply), 16-fold	20056955
Blind plate AirLINE Quick, 24-fold	20057392
Blind plate AirLINE Quick (valve terminal with intermediate supply), 24-fold	20057394

DTS 1000011132 EN Version: T Status: RL (released | freigegeben | validé) printed: 04.10.2023

8.5. Ordering chart spare parts

Spare parts SVVI for Type 8644, REV1 – Pneumatics 11 mm width per station

Pos.	Description	Content	Article no.
1	Spare valves see "8.3. Ordering chart replacement valves" on page 19	-	-
2	Cover plate see "8.4. Ordering chart accessories" on page 23	-	-
3	Set of valve seals	-	-
	Spare valve seals FM20 for Type 6524, 2 x 3/2-way solenoid valve	12	20016305
	Spare valve seals FM15 for Type 6524, 3/2-way solenoid valve	12	20024333
	Spare valve seats FM14 for Type 6525, 5/2-way solenoid valve	12	20024334
	Spare valve seals FM16 for Type 0460	12	20024330
4	Sets of module seals	-	-
	Spare module seals for Type MP11	4	20040779
5	Supply units	o. r.	o. r.
6	Base modules	o. r.	o. r.
7	Sets of electronic modules	-	-
	Electrical base module for Type 8644, 11 mm, 2-fold, impulse valve	1	20040558
	Electrical base module for Type 8644, 11 mm, 8-fold, impulse valve	1	20040559
	Electrical base module for Type 8644, 11 mm, 2-fold, single valve	1	20040560
	Electrical base module for Type 8644, 11 mm, 8-fold, single valve	1	20040561
	Electrical base module for Type 8644, 11 mm, 2-fold, double valve	1	20040562
	Electrical base module for Type 8644, 11 mm, 8-fold, double valve	1	20040563
8	AirLINE Quick spare parts see "8.4. Ordering chart accessories" on page 23	-	-

o. r. = on request

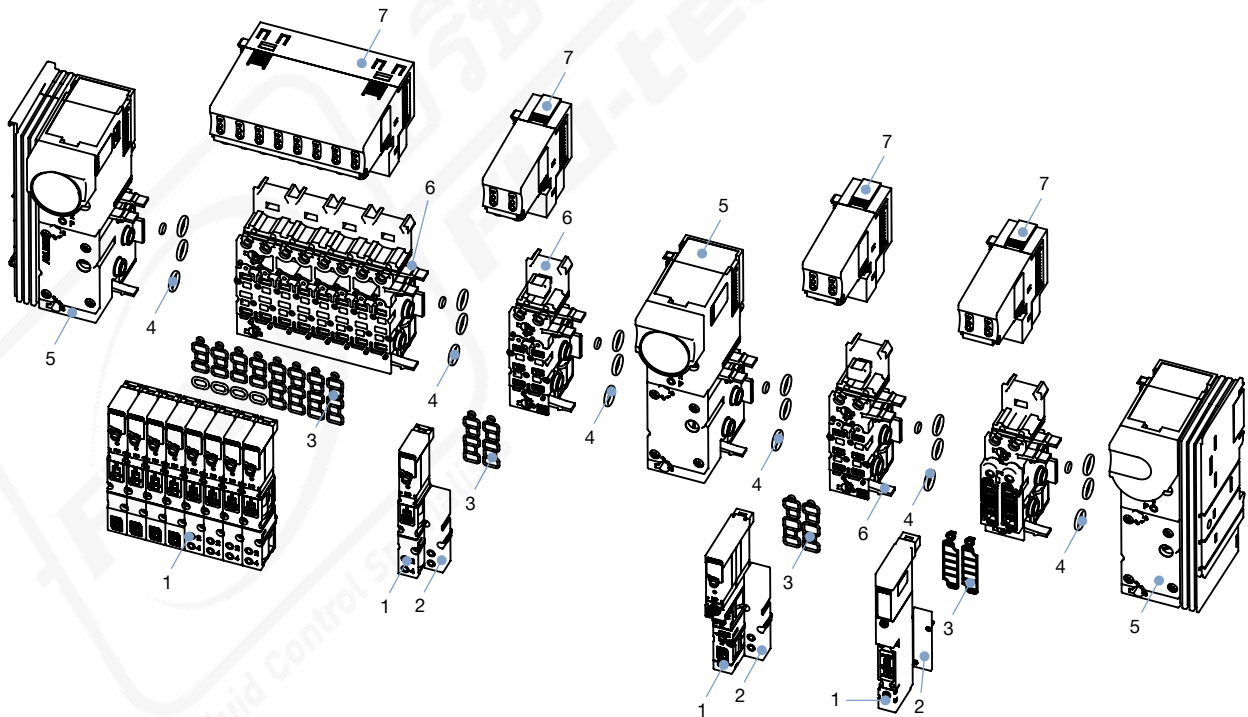

DTS 1000011132 EN Version: T Status: RL (released | freigegeben | valide) printed: 04.10.2023

Spare parts SVVI for Type 8644, REV1 – Pneumatics 16 mm width per station

Pos.	Description	Content	Article no.
1	Spare valves see “8.3. Ordering chart replacement valves” on page 19	–	–
2	Cover plate see “8.4. Ordering chart accessories” on page 23	–	–
3	Set of valve seals	–	–
	Spare valve seals FM17 for Type 6526 and Type 6527	12	20016307 ☒
	Spare valve seals FM19 for Type 0461	12	20024337 ☒
4	Sets of module seals	–	–
	Spare module seals for Type MP12	4	20036699 ☒
5	Supply units	o. r.	o. r.
6	Base modules	o. r.	o. r.
7	Electronic modules	o. r.	o. r.

o. r. = on request

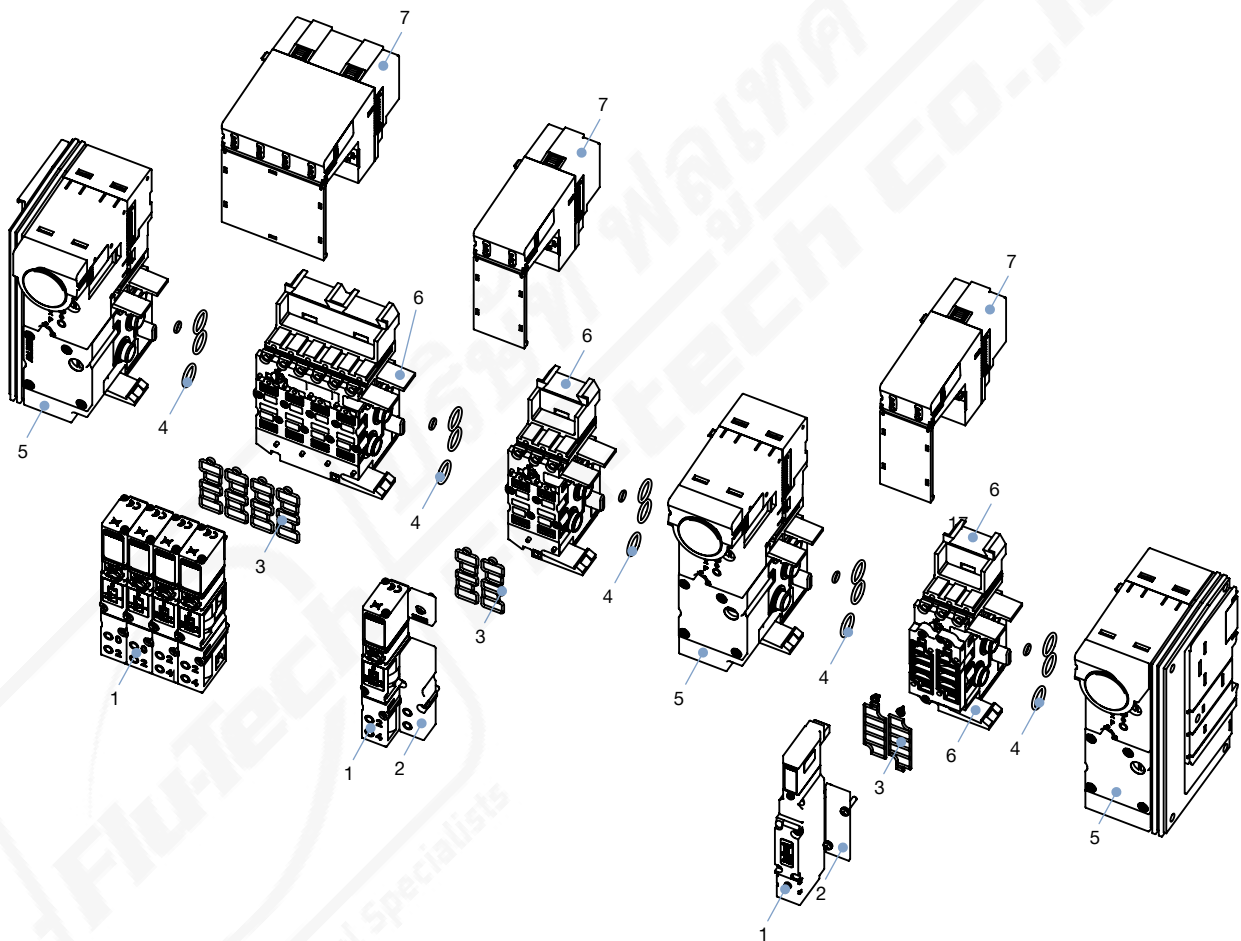

DTS 1000011132 EN Version: T Status: RL (released | freigegeben | valide) printed: 04.10.2023

Spare parts SVVI for Type 8644, REV2 – Pneumatics 11 mm width per station

Pos.	Bezeichnung	Inhalt	Artikel-Nr.
1	Spare valves see “8.3. Ordering chart replacement valves” on page 19	–	–
2	Cover plate see “8.4. Ordering chart accessories” on page 23	–	–
3	Set of valve seals	–	–
	Spare valve seals FM20 for Type 6524, 2 x 3/2-way solenoid valve	12	20016305
	Spare valve seals FM24 for Type 6524	12	20024336
	Spare valve seals FM16 for Type 0460	12	20024330
4	Sets of module seals	–	–
	Spare module seals for Type MP16	4	20024339
5	Supply units	–	–
	Left supply unit for Type 8644, 11 mm, G ¼, with manometer	1	20040346
	Right supply unit for Type 8644, 11 mm, G ¼, with manometer	1	20040347
	Intermediate supply for Type 8644, with manometer	1	20040348
	Right supply unit for Type 8644, 11 mm, G ¼, without manometer	1	20040349
	Intermediate supply for Type 8644, without manometer	1	20040350
6	Base modules	–	–
	Base unit for Type 8640, 8644, 8647, 11 mm, 4-fold, D6, FM20	1	20040334
	Base unit for Type 8640, 8644, 8647, 11 mm, 4-fold, D6, FM20, Hot Swap, RSV	1	20040335
	Base unit for Type 8640, 8644, 8647, 11 mm, 4-fold, D¼, FM20	1	20040337
	Base unit for Type 8640, 8644, 8647, 11 mm, 4-fold, D¼, FM20, Hot Swap, RSV	1	20040339
	Base unit for Type 8640, 8644, 8647, 11 mm, 4-fold, D6, FM16	1	20040340
	Base unit for Type 8640, 8644, 8647, 11 mm, 4-fold, D6, FM16, RSV	1	20040343
	Base unit for Type 8640, 8644, 8647, 11 mm, 4-fold, D¼, FM16	1	20040344
	Base unit for Type 8640, 8644, 8647, 11 mm, 4-fold, D¼, FM16, RSV	1	20040345
7	Electronic modules	–	–
	Electrical base module for Type 8644, 11 mm, 2-fold, impulse valve	1	20040558
	Electrical base module for Type 8644, 11 mm, 8-fold, impulse valve	1	20040559
	Electrical base module for Type 8644, 11 mm, 2-fold, single valve	1	20040560
	Electrical base module for Type 8644, 11 mm, 8-fold, single valve	1	20040561
	Electrical base module for Type 8644, 11 mm, 2-fold, double valve	1	20040562
	Electrical base module for Type 8644, 11 mm, 8-fold, double valve	1	20040563
8	AirLINE Quick spare parts see “8.4. Ordering chart accessories” on page 23	–	–

o. r. = on request

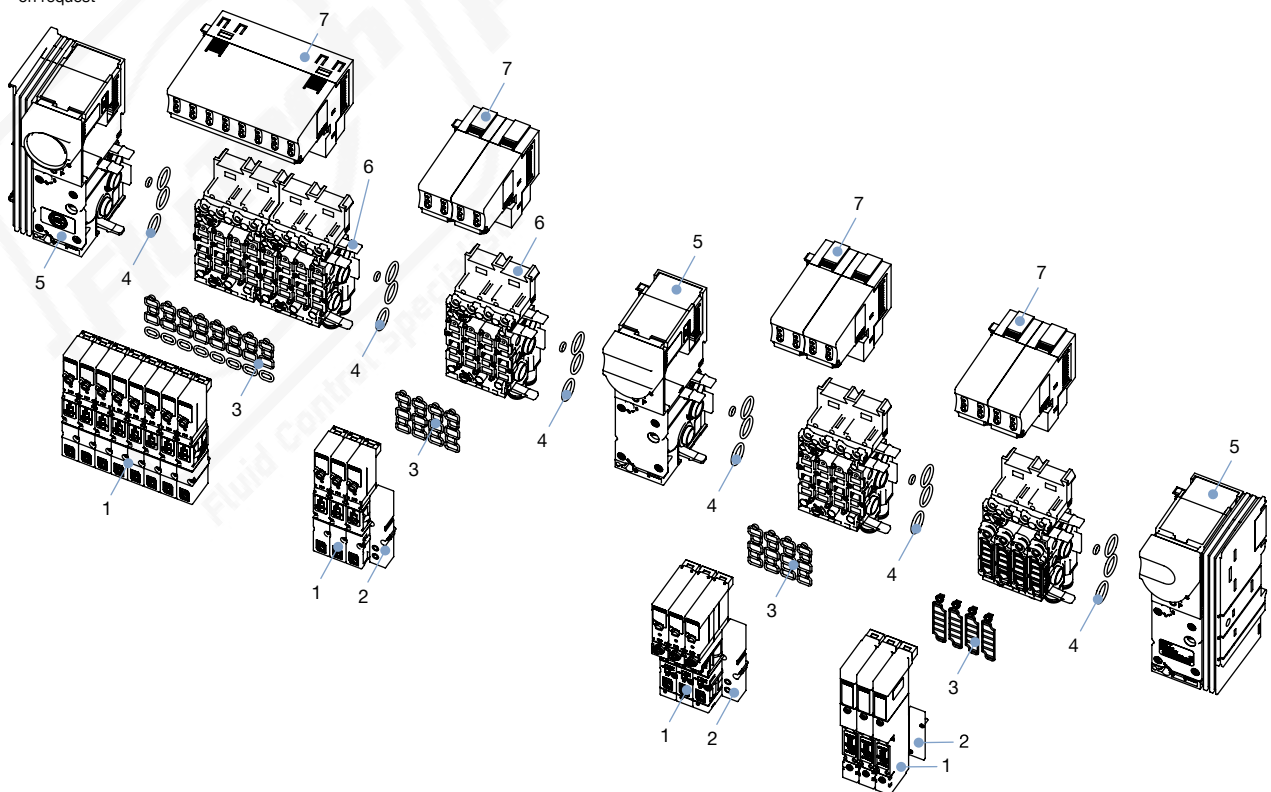

DTS 1000011132 EN Version: T Status: RL (released | freigegeben | valide) printed: 04.10.2023