





### Plunger valve 3/2-way direct-acting

- Direct-acting, compact valve with diameter of up to DN 2.5
- Vibration-proof, bolted coil system
- Banjo threaded connection for direct mounting on pneumatic valves
- Explosion proof versions
- Energy-saving version with Kick and Drop available

Product variants described in the data sheet may differ from the product presentation and description.

#### Can be combined with

	<b>Type 2518</b> Cable plug, form A according to DIN EN 175301-803	▶
	<b>Type 1087</b> Timer, form A according to DIN EN 175301 - 803	▶
	<b>Type 2509</b> Cable plug, form A according to DIN EN 175301-803	▶

#### Type description

Valve 6014 is a direct-acting plunger valve. The stopper and plunger guide tube are welded together to enhance pressure resistance and leak-tightness. Various seal material combinations are available depending on the application. A Bürkert-specific flange design (SFB) enables space-saving arrangement of valves on a manifold. Kick and Drop coils are available for the reduction of electrical power consumption during operation.



## Table of contents

<b>1. General technical data</b>	<b>4</b>
<b>2. Circuit functions</b>	<b>4</b>
<b>3. Approvals</b>	<b>5</b>
<b>4. Materials</b>	<b>5</b>
4.1. Chemical Resistance Chart – Bürkert resistApp.....	5
4.2. Material specifications .....	5
Standard version.....	5
Banjo version .....	6
ATEX/IECEX cable version .....	6
ATEX/IECEX terminal box version .....	7
<b>5. Dimensions</b>	<b>8</b>
5.1. Standard version.....	8
Pin assignment .....	8
5.2. Banjo version .....	9
5.3. ATEX/IECEX cable version .....	10
5.4. ATEX/IECEX m terminal box version .....	11
5.5. ATEX/IECEX ia version .....	12
5.6. Single manifold .....	13
5.7. Multiple manifold.....	14
Manifolds for block mounting .....	14
<b>6. Performance specifications</b>	<b>15</b>
6.1. Power consumption .....	15
6.2. Utilisation in another circuit function.....	15
6.3. Electrical data .....	15
<b>7. Product installation</b>	<b>16</b>
7.1. Installation notes.....	16
Control for impulse version with polarity reversal control.....	16
<b>8. Product accessories</b>	<b>17</b>
8.1. Cable glands for ATEX/IECEX terminal box .....	17
8.2. Special tool to turn the terminal box .....	17
<b>9. Ordering information</b>	<b>18</b>
9.1. Bürkert eShop – Easy ordering and quick delivery.....	18
9.2. Bürkert product filter .....	18
9.3. Ordering chart .....	18
Standard version.....	18
Banjo version .....	21
ATEX/IECEX m cable version .....	22
ATEX/IECEX m terminal box version .....	23
ATEX/IECEX ia version .....	24

9.4.	Ordering chart accessories.....	24
	Singel manifold .....	24
	Multiple manifold.....	24
	Cable plug Type 2518, form A according to DIN EN 175301 - 803 .....	24
	Cable plug Type 2513, form A according to DIN EN 175301 - 803 .....	25
	Cable glands for ATEX/IECEX terminal box .....	25

DTS 1000011035 EN Version: T Status: RL (released | freigegeben | valide) printed: 24.05.2023



## 1. General technical data

Product properties	
Dimensions	Detailed information can be found in chapter <b>"5. Dimensions"</b> on page 8.
<b>Material</b>	
Seal	FKM (EPDM on request)
Body	Brass or stainless steel 1.4305 / 303, polyamide (sub-base)
Coil	Polyamide (Epoxy on request)
Nominal diameter	DN1.5...DN2.5
Circuit function	C, D and T (see <b>"2. Circuit functions"</b> on page 4)
Thermal insulation class of solenoid coil	Polyamide class B Epoxy class H
Performance data	
Duty cycle / single valve assembly	100 % continuous rating Intermittent operation 60 % (30 min) or with 5 W coil (on request)
Electrical data	
Operating voltage	24 V DC, 24 V/50 Hz, 24 V/60 Hz, 110 V/50 Hz, 120 V/60 Hz, 230 V/50 Hz, 240 V/60 Hz (other voltages on request)
Voltage tolerance	± 10 %
Medium data	
Operating medium	Neutral gases and fluids (e.g. compressed air, town gas, natural gas, water, hydraulic oil, petrol). Suitable for technical vacuum.
<b>Medium temperature</b>	
With FKM	-10 °C...+100 °C (PA coil), -10 °C...+120 °C (Epoxy coil), -40 °C on request
With PTFE/Graphite	-40 °C...+180 °C (see <b>"4.1. Chemical Resistance Chart – Bürkert resistApp"</b> on page 5)
With FKM, circuit function B	-10 °C...100 °C (AC),...10 °C...120 °C (DC)
Viscosity	Max. 21 mm <sup>2</sup> /s
Process/Port connection & communication	
Port connection	G 1/8, G 1/4, NPT 1/8, NPT 1/4, sub-base (SFB)
Electrical connection	DIN EN 175 301-803 form A for cable plug Type 2518 (see <b>"9.4. Ordering chart accessories"</b> on page 24) ATEX/IECEx version with 3 m moulded cable encapsulated
Approvals and certificates	
Degree of protection	IP65 with cable plug <b>Type 2518</b> ▶ NEMA 4X with cable plug <b>Type 2509</b> ▶ with stainless steel versions ATEX/IECEx terminal box version and cable connection version
Environment and installation	
Installation position	Any, preferably actuator upright
Ambient temperature	Max. +55 °C

## 2. Circuit functions

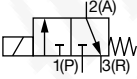
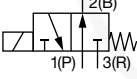
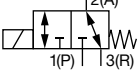
Symbol	Description
	<b>Circuit function C (CF C)</b> 3/2-way solenoid valve Direct-acting Normally closed
	<b>Circuit function D (CF D)</b> 3/2-way solenoid valve Direct-acting Normally open
	<b>Circuit function T (CF T)</b> 3/2-way solenoid valve Direct-acting Flow direction optional Normally closed

### 3. Approvals

Approvals	Description
	<b>ATEX and IECEx approval for coils with fixed cable outlet</b> ATEX: EPS 21 ATEX 1 234 X II 3G Ex ec IIC T4 Gc/II 3D Ex tc IIIC T130°C Dc IECEx: IECEX EPS 21.0078X II 3G Ex ec IIC T4 Gc/II 3D Ex tc IIIC T130°C Dc
	<b>ATEX and IECEx approval for coils with terminal box</b> ATEX: PTB 15 ATEX 1011 U IECEx: IECEX PTB 15.0037 U

### 4. Materials

#### 4.1. Chemical Resistance Chart – Bürkert resistApp

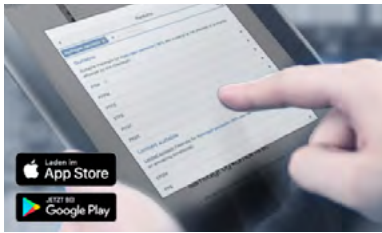

**Bürkert resistApp – Chemical Resistance Chart**

You want to ensure the reliability and durability of the materials in your individual application case? Verify your combination of media and materials on our website or in our resistApp.

[Start Chemical Resistance Check](#)

#### 4.2. Material specifications

##### Standard version

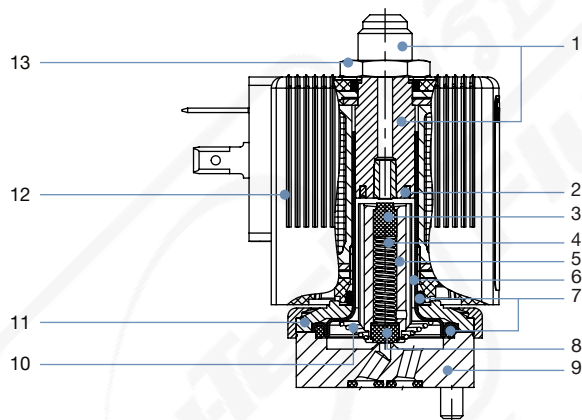

No.	Element	Material
1	Stopper	Stainless steel 1.4105/430F
2	Shading ring	Cu (brass version) Ag (stainless steel version)
3	Plunger seal	FKM
4	Spring	Stainless steel 1.4310/301
5	Magnetic core	Stainless steel 1.4105/430F
6	Armature guide tube	Stainless steel 1.4303/305/308
7	O-rings	FKM
8	Plunger seal	FKM
9	Valve body	Brass Stainless steel 1.4305/303 Stainless steel 1.4401/316
10	Spring	Stainless steel 1.4310/301
11	Sub-base	Steel, surface finish thick-film passivated (brass version) Stainless steel 1.4301/304 (stainless steel version)
12	Coil	PA (Polyamide) Epoxy (High temperature version)
13	Locknut	Steel, surface finish thick-film passivated (brass version) Stainless steel 1.4305/303 PTFE coated (stainless steel version)

Banjo version

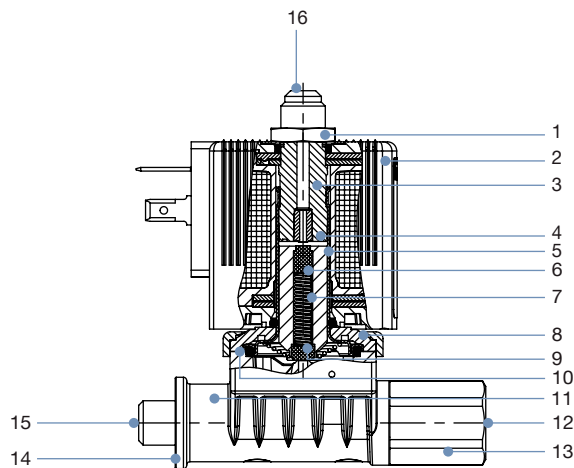

No.	Element	Material
1	Locknut	Steel, surface finish thick-film passivated (brass version) Stainless steel 1.4305/303 PTFE coated (stainless steel version)
2	Coil	PA (Polyamide) Epoxy (High temperature version)
3	Stopper	Stainless steel 1.4105/430F
4	Shading ring	Cu (brass version) Ag (stainless steel version)
5	Armature guide tube	Stainless steel 1.4303/305/308
6	Magnetic core	Stainless steel 1.4105/430F
7	Spring	Stainless steel 1.4310/301
8	Sub-base	Steel, surface finish thick-film passivated (brass version) Stainless steel 1.4301/304 (stainless steel version)
9	Plunger seal	FKM
10	O-rings	FKM
11	Valve body	PPS
12	Pressure connection P	-
13	Screw	Brass/Stainless steel 1.4301/304
14	O-rings	NBR
15	Pressure connection A	-
16	R connection	-

ATEX/IECEx cable version

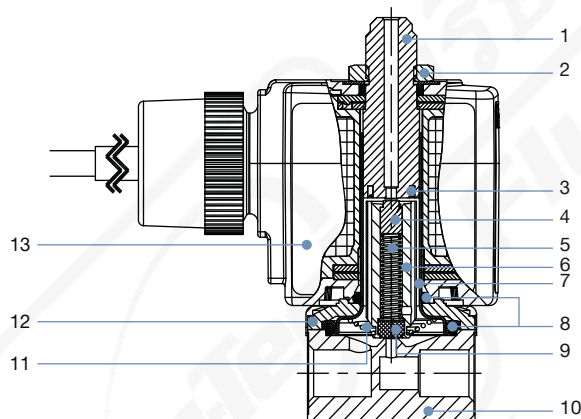

No.	Element	Material
1	Stopper	Stainless steel 1.4105/430F
2	Locknut	Steel, surface finish thick-film passivated (brass version) Stainless steel 1.4305/303 PTFE coated (stainless steel version)
3	Shading ring	Cu (brass version) Ag (stainless steel version)
4	Plunger seal	FKM
5	Spring	Stainless steel 1.4310/301
6	Magnetic core	Stainless steel 1.4105/430F
7	Armature guide tube	Stainless steel 1.4303/305/308
8	O-rings	FKM
9	Plunger seal	FKM
10	Valve body	Brass Stainless steel 1.4305/303 Stainless steel 1.4401/316
11	Spring	Stainless steel 1.4310/301
12	Sub-base	Steel, surface finish thick-film passivated (brass version) Stainless steel 1.4301/304 (stainless steel version)
13	Coil	Epoxy

DTS 1000011035 EN Version: T Status: RL (released | freigegeben | valide) printed: 24.05.2023

ATEX/IECEx terminal box version

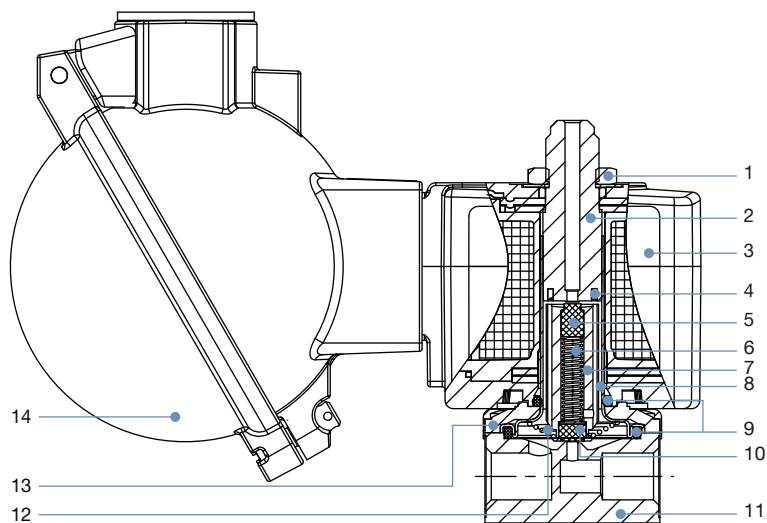

No.	Element	Material
1	Locknut	Steel, surface finish thick-film passivated (brass version) Stainless steel 1.4305/303 PTFE coated (stainless steel version)
2	Stopper	Stainless steel 1.4105/430F
3	Coil	Epoxy
4	Shading ring	Cu (brass version) Ag (stainless steel version)
5	Plunger seal	FKM
6	Spring	Stainless steel 1.4310/301
7	Magnetic core	Stainless steel 1.4105/430F
8	Armature guide tube	Stainless steel 1.4303/305/308
9	O-rings	FKM
10	Plunger seal	FKM
11	Valve body	Brass Stainless steel 1.4305/303 (G 1/8) Stainless steel 1.4401/316 (G 1/4)
12	Spring	Stainless steel 1.4310/301
13	Sub-base	Steel, surface finish thick-film passivated (brass version) Stainless steel 1.4301/304 (stainless steel version)
14	Terminal box	Aluminium

DTS 1000011035 EN Version: T Status: RL (released | freigegeben | valide) printed: 24.05.2023

## 5. Dimensions

### 5.1. Standard version

**Note:**

Dimensions in mm

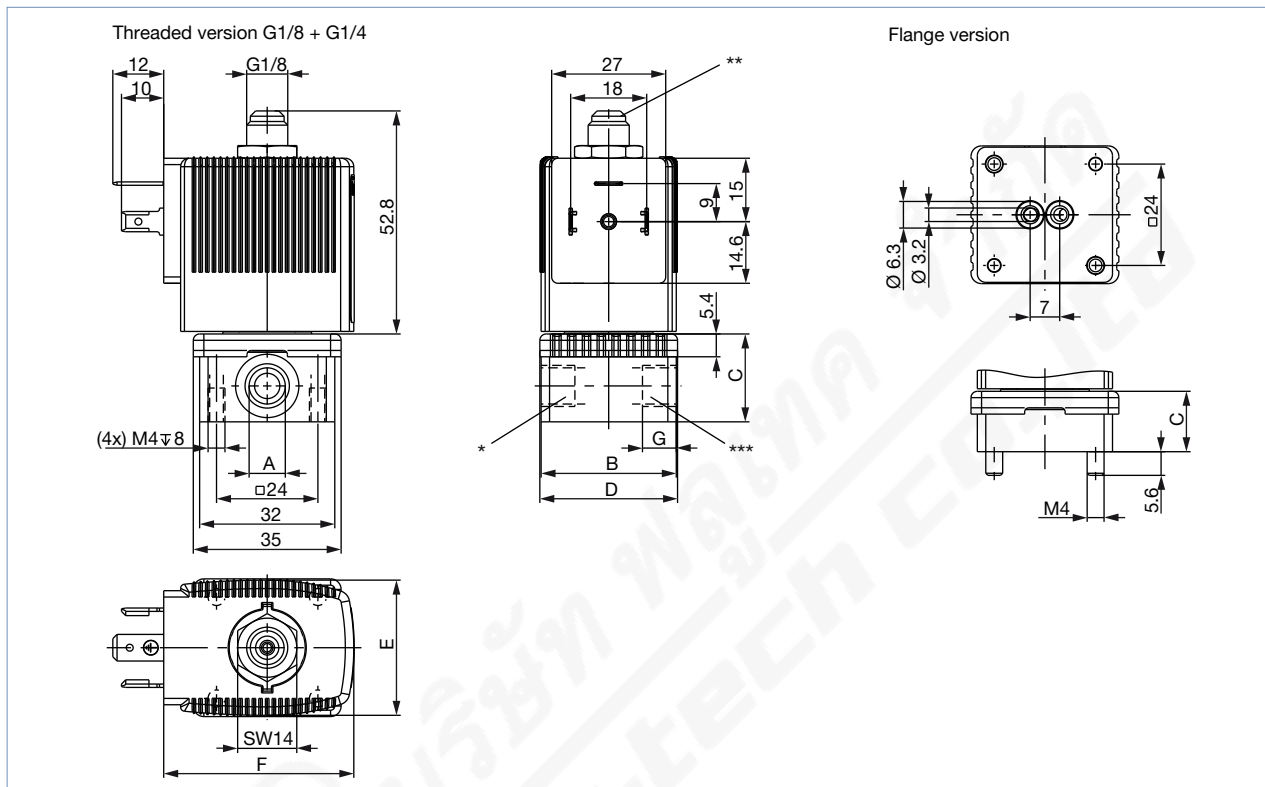

Port connection	A	B	C	D	G
	[inch]	[mm]	[mm]	[mm]	[mm]
Threaded without manual override	G 1/8	32	20.8	32.6	8
	G 1/4	46	26.8	49	12
Threaded with manual override	G 1/8	32	20.8	32.6	8
	G 1/4	46	26.8	49	12
Sub-base	-	32	14.3	32.6	-

Coil size	E	F
	[mm]	[mm]
5	32	45
6	40	51

#### Pin assignment

For the positions marked with \*, \*\* or \*\*\* in the drawing, the connections are marked with the letters shown in the table above, depending on the circuit function. Unused circuit functions A or B connections will be closed off with a blanking plug or cap nut.

Circuit function	Connection Type		
	*	**	***
A	P	blank off	A
B	blank off	B	P
C	P	R	A
D	R	P	B
T	P	R	A



**5.2. Banjo version**

**Note:**

Dimensions in mm

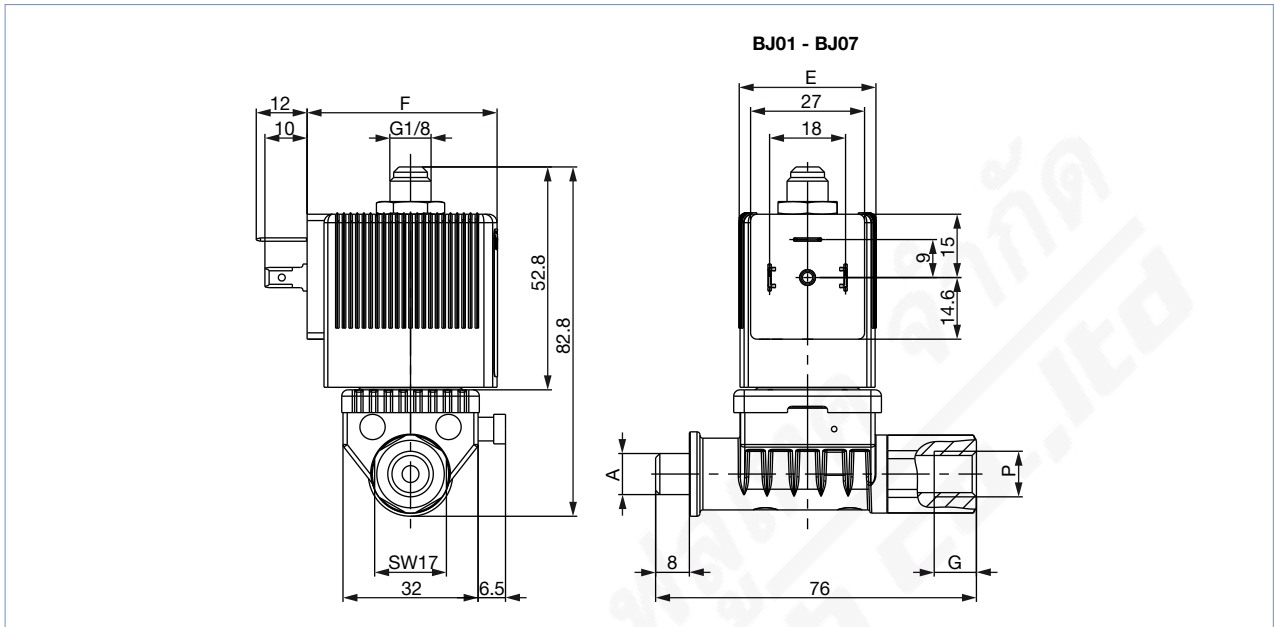

Port connection	A	P	G
	[inch]	[inch]	[mm]
BJ01	G 1/8	G 1/8	10
BJ02	G 1/4	G 1/4	10
BJ03	G 1/8	NPT 1/4	10
BJ04	G 1/4	NPT 1/4	10
BJ05	G 1/8	G 1/4	10
BJ06	G 1/4	G 1/8	10
BJ07	G 1/8	NPT 1/8	10

Coil size	E	F
	[mm]	[mm]
5	32	45
6	40	51

DTS 1000011035 EN Version: T Status: RL (released | freigegeben | valide) printed: 24.05.2023

5.3. ATEX/IECEX cable version

Note:

Dimensions in mm

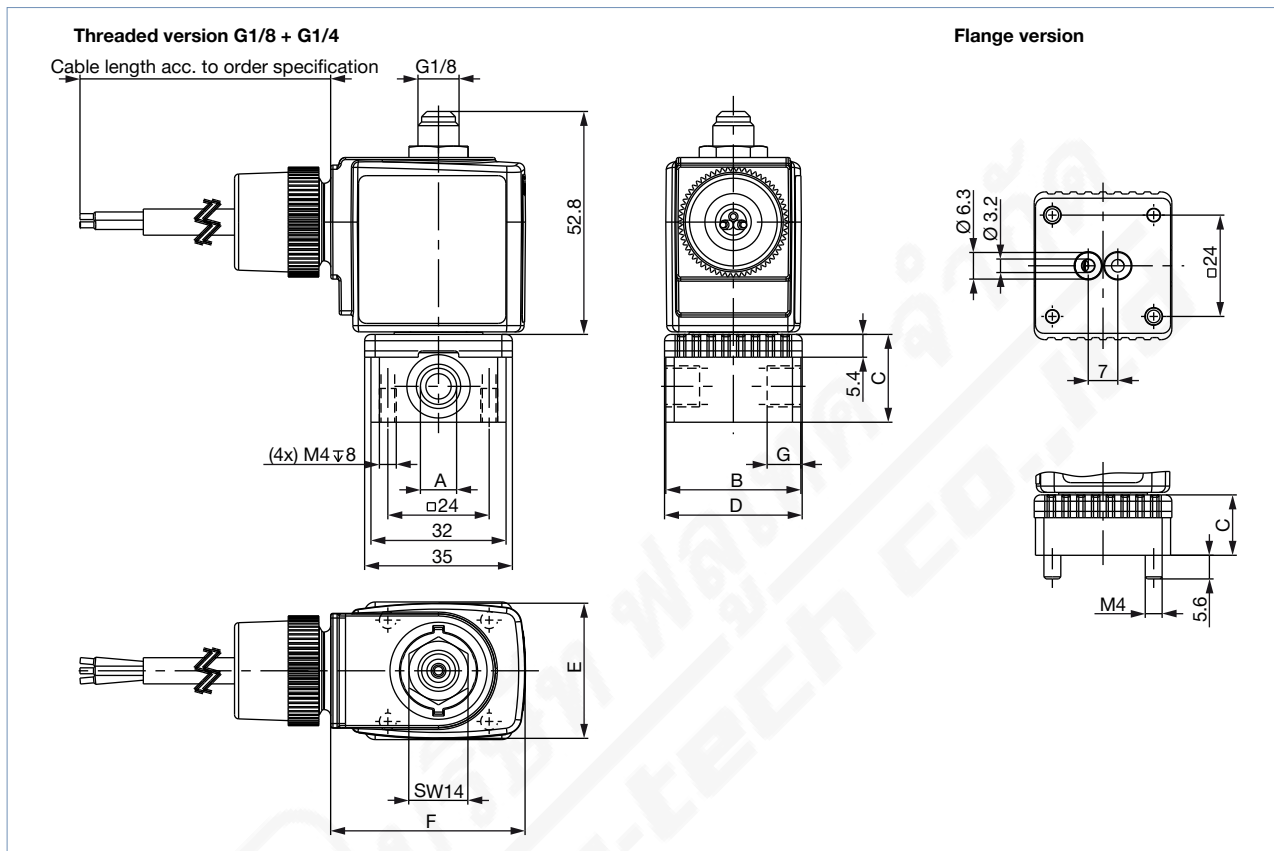

Port connection	A	B	C	D	G
	[inch]	[mm]	[mm]	[mm]	[mm]
Threaded version	G 1/8	32	20.8	32.6	8
	G 1/4	46	26.8	49	12
Sub-base version	-	32	14.3	32.6	-

Coil size	E	F
	[mm]	[mm]
5	32	46
6	40	52

DTS 1000011035 EN Version: T Status: RL (released | freigegeben | valide) printed: 24.05.2023

5.4. ATEX/IECEX m terminal box version

**Note:**

Dimensions in mm

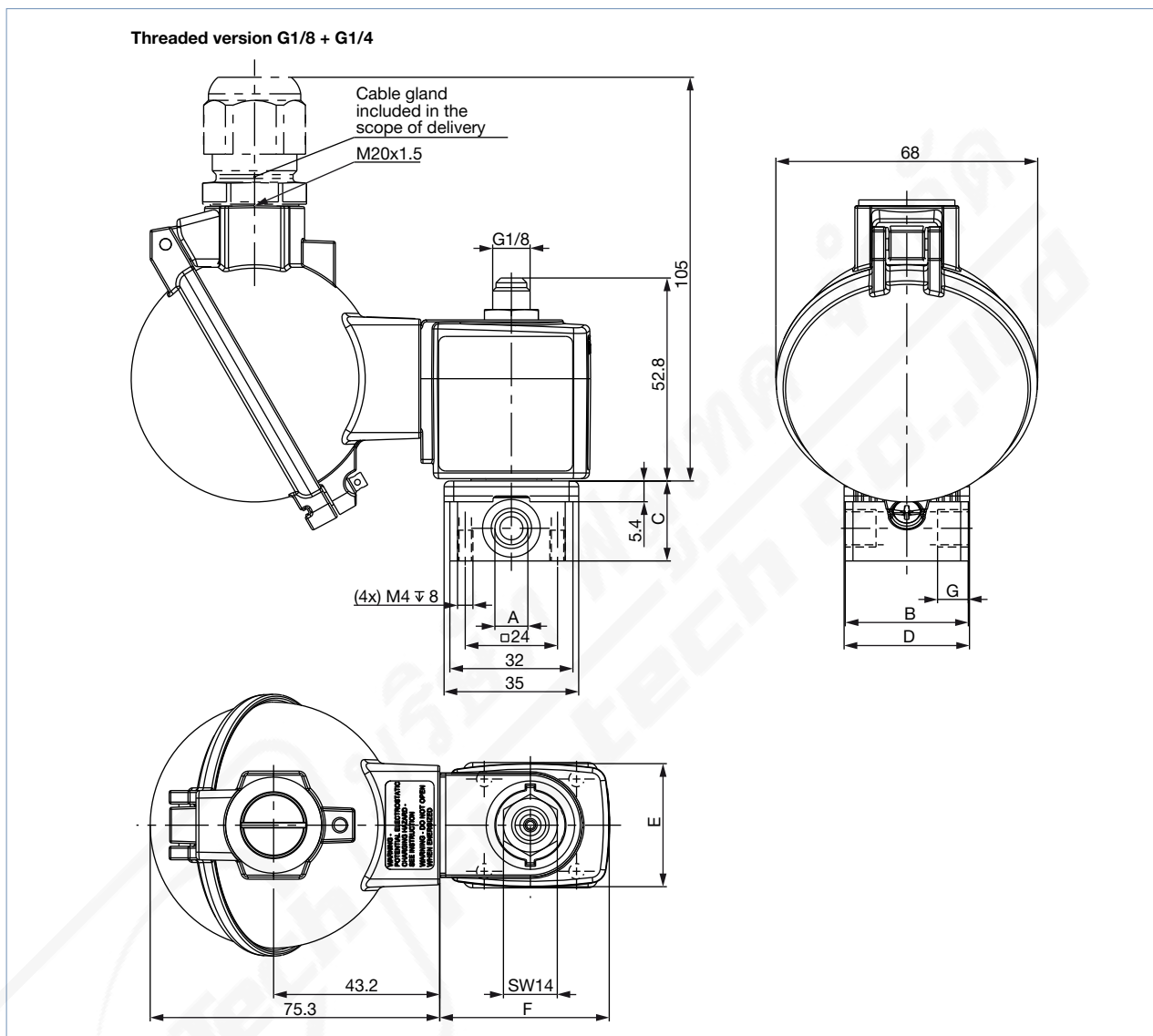

Port connection	A	B	C	D	G
	[inch]	[mm]	[mm]	[mm]	[mm]
Threaded version	G 1/8	32	20.8	32.6	8
	G 1/4	46	26.8	49	12
Sub-base version	-	32	14.3	32.6	-

Coil size	E	F
	[mm]	[mm]
5	32	44
6	40	51

DTS 1000011035 EN Version: T Status: RL (released | freigegeben | valide) printed: 24.05.2023

5.5. ATEX/IECEX ia version

Note:

- Dimensions in mm
- Detailed information about electrical data see “6.3. Electrical data” on page 15.

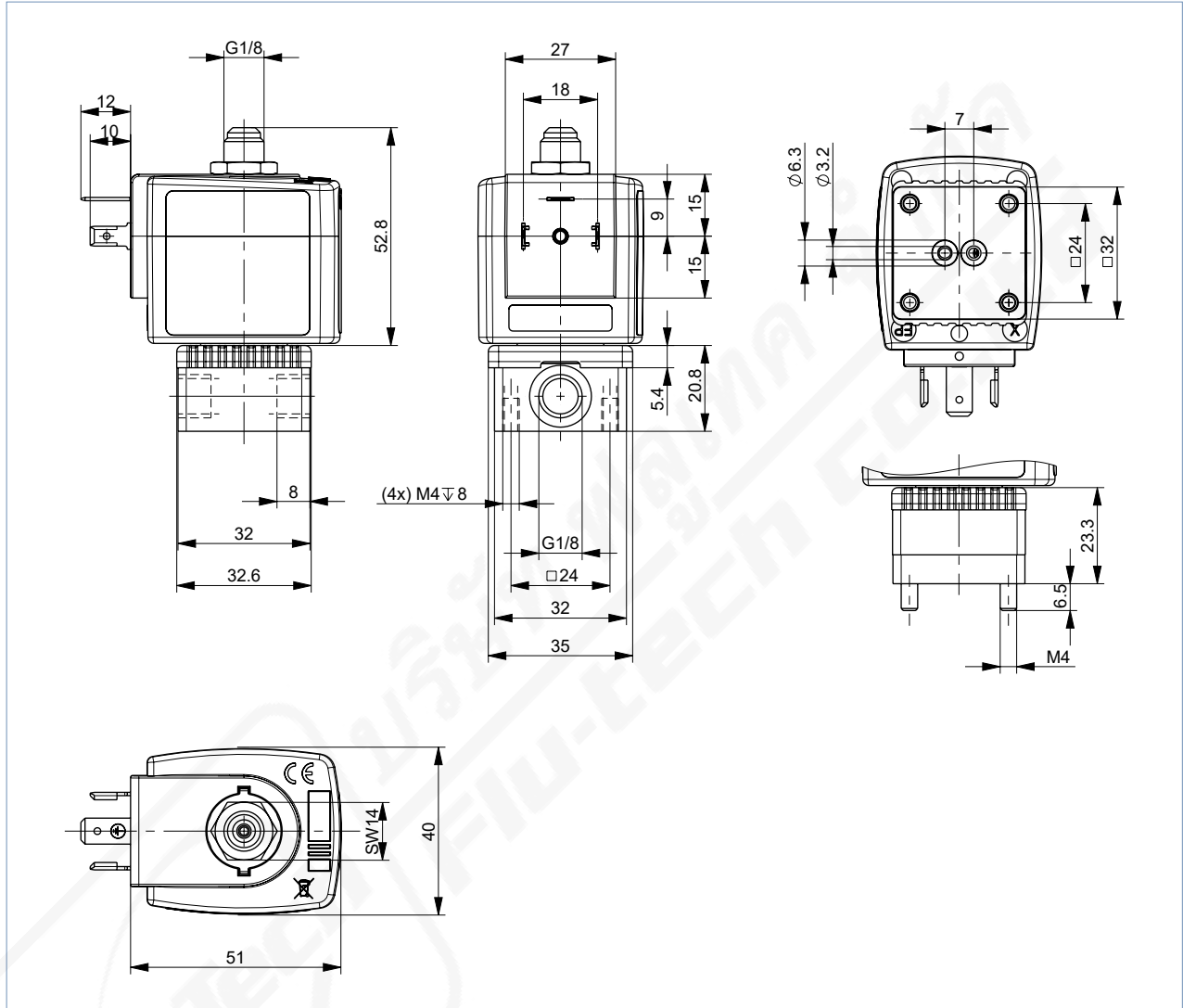

DTS 1000011035 EN Version: T Status: RL (released | freigegeben | valide) printed: 24.05.2023

### 5.6. Single manifold

**Note:**

- Dimensions in mm
- For detailed information on the installation of manifolds, see “Manifolds for block mounting” on page 14.

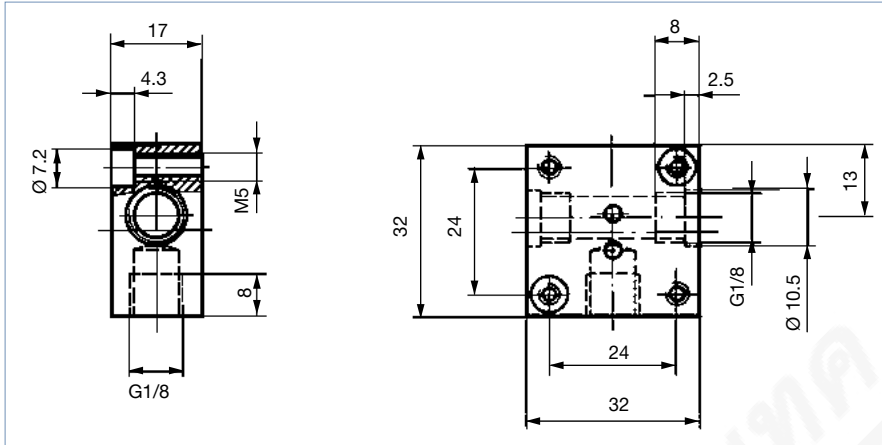

## 5.7. Multiple manifold

### Note:

- Dimensions in mm
- Manifold only possible with coil size 5
- Brass or stainless steel manifolds on request

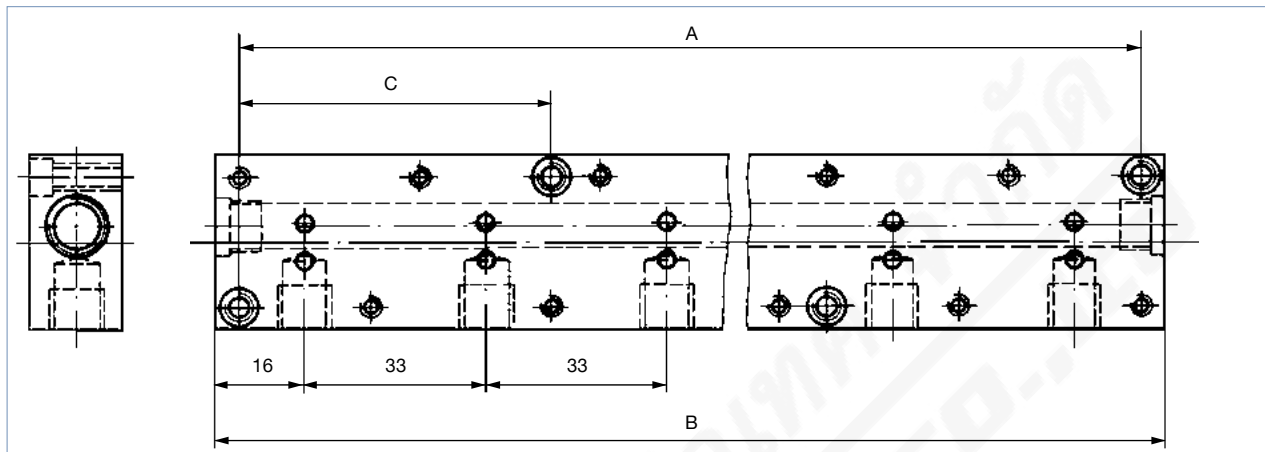

Accessory parts	Number of valve positions	Hole spacing A [mm]	Total length B [mm]	Hole spacing C [mm]	Article no.
Multiple manifold (aluminium)	2	57	65	–	005023
	3	90	98	–	005286
	4	123	131	–	005287
	5	156	164	57	005035
	6	189	197	57	005038
	8	255	263	90	005386
	10	321	329	90	005764
Single manifold (aluminium)					005020
Plug nipple with O-rings for connecting manifolds					005040
Covering plate with screws and O-ring for closing off unused valve positions					005630

### Manifolds for block mounting

#### Note:

- Unused, open valve ports must be closed off with covering plates (see accessories).
- Manifold should be fixed on to a rail.
- For detailed information on dimensions [“5.7. Multiple manifold” on page 14.](#)

With manifold mounting, please comply with the permissible duty cycle (5 W versions with 100 % continuous rating or 8 W version with 60 % duty cycle). The pressure port for the manifold is designated with P (R), and the outlet port with A (B). Only connect together ports with the same designation.

2/2 way valves of Type 6013 can be operated together on a manifold with 3/2 way valves of Type 6014, circuit function C (not D or T) if the operating pressures matches according to the rating plates. The manifolds can also be expanded if the valve functions are taken into consideration. Connector nipples with O-rings are used to connect the P (R) ports.

## 6. Performance specifications

### 6.1. Power consumption

Orifice [mm]	Power consumption				Response times <sup>1.)</sup>	
	Inrush AC [VA]	UC [W]	Hold AC [VA/W]	UC [W]	Opening [ms]	Closing [ms]
1.5	24	17	8	8/9	10...15	15...20
2.0					10...15	15...20
2.5					15...20	10...22

1.) Measurement at 6 bar and +20 °C at the valve outlet, opening: pressure build-up 0...90 %, closing: pressure reduction 100...10 %

### 6.2. Utilisation in another circuit function

The valves are equipped with different springs for specific circuit functions. When used with other circuit functions, the permissible operating pressure changes according to the following table.

DN	Standard version Circuit function	Max. operating pressure [bar] for valve application in circuit function				
		A	B	C	D	T
1.5	C	16	22	16	2	2
	D	2	2.5	2	16	2
	T	10	16	10	6	6
2.0	C	10	14	10	1	1
	D	1	1.5	1	10	1
	T	6	10	6	4	4
2.5	C	6	9	6	0.7	0.7
	D	0.7	1	0.7	6	0.7
	T	3.5	6	3.5	2.5	2.5

### 6.3. Electrical data

#### Note:

The valve is designed to operate on 24 V DC outputs through an intermediary intrinsically safe apparatus (isolating block or barrier). Detailed information can be found in the **operating instructions EPS 18 ATEX 1088X** ▶.

Type of protection EEx ia IIC T6 acc. to PTB-No. Ex-96.D.2010

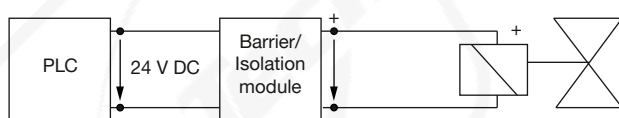

## 7. Product installation

### 7.1. Installation notes

#### Control for impulse version with polarity reversal control

**Note:**

- Please use only the cable plug without electrical circuitry for the impulse version!
- Pulse duration at least 50 ms

Polarity (is marked on the coil with a label)	Features	Terminal connections
- switch ON +	valve open	(+) on terminal 2 and (-) on terminal 1 (see below)
+ switch OFF -	valve closed	(+) on terminal 1 and (-) on terminal 2 (see below)



DTS 1000011035 EN Version: T Status: RL (released | freigegeben | valide) printed: 24.05.2023





## 8. Product accessories

### 8.1. Cable glands for ATEX/IECEX terminal box

**Note:**

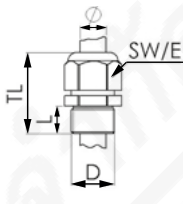
A cable gland in polyamide version is included in the delivery. A nickel-plated brass version can be ordered at a surcharge, see “9.4. Ordering chart accessories” on page 24.

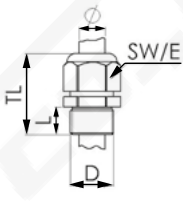
Description	Ex approvals		Dimensions										
	Certification	Identification											
Ex cable gland, Brass, nickel-plated, 6...13 mm 	PTB 04 ATEX 1112 X, IECEX PTB 13.0027X	II 2 G Ex e IIC Gb, II 2 D Ex tb IIIC Db IP68	 <table border="1"> <tr><td>TL</td><td>29...37 mm</td></tr> <tr><td>L</td><td>6 mm</td></tr> <tr><td>D</td><td>20 mm</td></tr> <tr><td>SW</td><td>24 mm</td></tr> <tr><td>E</td><td>27 mm</td></tr> </table>	TL	29...37 mm	L	6 mm	D	20 mm	SW	24 mm	E	27 mm
TL	29...37 mm												
L	6 mm												
D	20 mm												
SW	24 mm												
E	27 mm												
Ex cable gland, Polyamide, 7...13 mm 	PTB 13 ATEX 1015 X, IECEX PTB 13.0034X	II 2 G Ex e IIC Gb, II 2 D Ex tb IIIC Db IP68	 <table border="1"> <tr><td>TL</td><td>36...45 mm</td></tr> <tr><td>L</td><td>10 mm</td></tr> <tr><td>D</td><td>20 mm</td></tr> <tr><td>SW</td><td>24 mm</td></tr> <tr><td>E</td><td>28 mm</td></tr> </table>	TL	36...45 mm	L	10 mm	D	20 mm	SW	24 mm	E	28 mm
TL	36...45 mm												
L	10 mm												
D	20 mm												
SW	24 mm												
E	28 mm												

### 8.2. Special tool to turn the terminal box

**Note:**

This special tool is not supplied with the valve, see “9.4. Ordering chart accessories” on page 24.

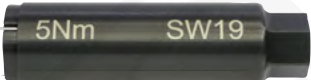
Description	Components of the set
Set SC02-AC10 	<ul style="list-style-type: none"> <li>• Special wrench</li> <li>• Service manual</li> </ul>

DTS 1000011035 EN Version: T Status: RL (released | freigegeben | valide) printed: 24.05.2023

## 9. Ordering information

### 9.1. Bürkert eShop – Easy ordering and quick delivery



**Bürkert eShop – Easy ordering and quick delivery**

You want to find your desired Bürkert product or spare part quickly and order directly? Our online shop is available for you 24/7. Sign up and enjoy all the benefits.

Order online now

### 9.2. Bürkert product filter



**Bürkert product filter – Get quickly to the right product**

You want to select products comfortably based on your technical requirements? Use the Bürkert product filter and find suitable articles for your application quickly and easily.

Try out our product filter

### 9.3. Ordering chart

#### Standard version

**Note:**

Please note that the cable plug has to be ordered separately, see “9.4. Ordering chart accessories” on page 24 or separate datasheet **Type 2518** ▶.

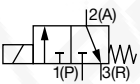
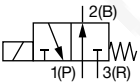
Circuit function	Port connection	Orifice [mm]	K <sub>v</sub> value water <sup>1)</sup> [m <sup>3</sup> /h]	Coil power [W]	Pressure range <sup>2)</sup> [bar]	Article no.		
						024/DC [V/Hz]	024/50 [V/Hz]	230/50 [V/Hz]
<b>Threaded version with FKM seal, (class B)</b>								
<b>Brass body</b>								
<b>CF C</b> 3/2-way solenoid valve Direct-acting Normally closed 	G 1/8	1.5	0.07	8	0...16	125329	125331	125332
	G 1/8	2.0	0.11	8	0...10	125333	125334	125336
	G 1/4		0.11	8	0...10	125348	126138	126140
	G 1/8	2.5	0.16	8	0...6	125341	125340	125342
	G 1/4		0.16	8	0...6	126142	126143	126145
<b>CF D</b> 3/2-way solenoid valve Direct-acting Normally open 	G 1/8	1.5	0.07	8	0...16	126195	126196	125355
	G 1/8	2.0	0.11	8	0...10	125357	125358	125360
	G 1/4		0.11	8	0...10	126198	126199	126201
	G 1/8	2.5	0.16	8	0...6	125363	126202	126204
	G 1/4		0.16	8	0...6	126205	126206	126208

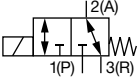
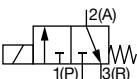
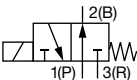
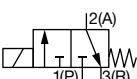
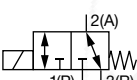
Circuit function	Port connection	Orifice [mm]	K <sub>v</sub> value water <sup>1.)</sup> [m <sup>3</sup> /h]	Coil power [W]	Pressure range <sup>2.)</sup> [bar]	Article no.		
						024/DC [V/Hz]	024/50 [V/Hz]	230/50 [V/Hz]
<b>CF T</b> 3/2-way solenoid valve Direct-acting Flow direction optional Normally closed 	G 1/8	1.5	0.07	8	0...7	126150 ☒	126151 ☒	126153 ☒
	<b>With manual override</b>							
<b>CF C</b> 3/2-way solenoid valve Direct-acting Normally closed 	G 1/8	2.0	0.11	8	0...10	125337 ☒	125338 ☒	125339 ☒
	G 1/4		0.11	8	0...10	125349 ☒	126147 ☒	126149 ☒
<b>CF D</b> 3/2-way solenoid valve Direct-acting Normally open 	G 1/8	2.0	0.11	8	0...10	126209 ☒	125361 ☒	126211 ☒
	G 1/4		0.11	8	0...10	126212 ☒	126213 ☒	126215 ☒
<b>Stainless steel body</b>								
<b>CF C</b> 3/2-way solenoid valve Direct-acting Normally closed 	G 1/8	1.5	0.07	8	0...16	126216 ☒	126217 ☒	126219 ☒
	G 1/8	2.0	0.11	8	0...10	126220 ☒	126221 ☒	126223 ☒
	G 1/4	2.0	0.11	8	0...10	126224 ☒	126225 ☒	126227 ☒
<b>CF T</b> 3/2-way solenoid valve Direct-acting Flow direction optional Normally closed 	G 1/8	1.5	0.07	8	0...7	126228 ☒	126229 ☒	126231 ☒

1.) Measurement at 1 bar<sup>2.)</sup> and +20 °C at the valve inlet and free outlet

2.) Pressure data: Overpressure to atmospheric pressure

**Note:**

Please note that the cable plug must be ordered separately, see “9.4. Ordering chart accessories” on page 24 or separate datasheet **Type 2518** ▶.

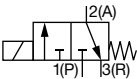
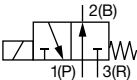
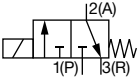
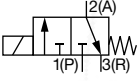
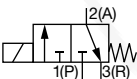
Circuit function	Orifice [mm]	K <sub>v</sub> value water <sup>1)</sup> [m <sup>3</sup> /h]	Coil power [W]	Pressure range <sup>2)</sup> [bar]	Article no.		
					024/DC [V/Hz]	024/50 [V/Hz]	230/50 [V/Hz]
<b>Sub-base body (SFB) with FKM seal (class B)</b>							
<b>Brass body</b>							
<b>CF C</b> 3/2-way solenoid valve Direct-acting Normally closed 	1.5	0.07	8	0...16	126154 ☒	126155 ☒	125366 ☒
	2.0	0.11	8	0...10	125367 ☒	125368 ☒	125370 ☒
<b>CF D</b> 3/2-way solenoid valve Direct-acting Normally open 	2.0	0.11	8	0...10	126161 ☒	126162 ☒	125383 ☒
<b>With manual override</b>							
<b>CF C</b> 3/2-way solenoid valve Direct-acting Normally closed 	1.5	0.07	5	0...10	126403 ☒	126404 ☒	126406 ☒
	1.5	0.07	8	0...16	126157 ☒	126158 ☒	126160 ☒
	2.0	0.11	5	0...6	126407 ☒	126408 ☒	126410 ☒
	2.0	0.11	8	0...10	125371 ☒	125372 ☒	125374 ☒
<b>Polyamide body</b>							
<b>CF C</b> 3/2-way solenoid valve Direct-acting Normally closed 	1.5	0.07	5	0...10	126390 ☒	126391 ☒	126393 ☒
<b>With manual override</b>							
<b>CF C</b> 3/2-way solenoid valve Direct-acting Normally closed 	1.5	0.07	5	0...10	126396 ☒	126397 ☒	126399 ☒

1.) Measurement at 1 bar<sup>2)</sup> and +20 °C at the valve inlet and free outlet

2.) Pressure data: Overpressure to atmospheric pressure

Circuit function	Port connection		Orifice	K <sub>v</sub> value water <sup>1.)</sup>	Power consumption DC (hot/cold coil)	Pressure range <sup>2.)</sup>	Article no.	
			[mm]	[m <sup>3</sup> /h]			[W]	[bar]
Impulse version with FKM seal and brass body (class H)								
<b>CF C</b> 3/2-way solenoid valve Direct-acting Normally closed 	Threaded port	G 1/8	1.5	0.07	7	0...16	209280 ☒	209284 ☒
			2.0	0.11	7	0...10	209281 ☒	209285 ☒
	Sub-base {SFB}	Sub-base {SFB}	1.5	0.07	7	0...16	209278 ☒	209282 ☒
			2.0	0.11	7	0...10	209279 ☒	209283 ☒

1.) Measurement at 1 bar<sup>2.)</sup> and +20 °C at the valve inlet and free outlet  
 2.) Pressure data: Overpressure to atmospheric pressure

**Banjo version**

**Note:**

- Please note that the cable plug must be ordered separately, see **“Cable plug Type 2518, form A according to DIN EN 175301 - 803” on page 24** or separate data sheet **Type 2518** ▶
- Stainless steel banjo bolt on request

Circuit function	Pressure inlet P	Service port A (banjo bolt)	Orifice	Q <sub>Nn</sub> value air	Power consumption	Pressure range	Material banjo bolt	Article no.		
			[mm]	[l/min]				[W]	[bar]	024/DC
With FKM seal and manual override										
<b>CF C</b> 3/2-way solenoid valve Direct-acting Normally closed 	G 1/8	G 1/8	1.5	75	8	0...16	Brass	342402 ☒	389539 ☒	389541 ☒
	G 1/4	G 1/4	1.5	75	8	0...16	Brass	334869 ☒	389542 ☒	389543 ☒
	G 1/8	G 1/8	2.0	120	8	0...10	Brass	342403 ☒	389545 ☒	389547 ☒
	G 1/4	G 1/4	2.0	120	8	0...10	Brass	334870 ☒	389548 ☒	389550 ☒

X: on request

DTS 1000011035 EN Version: T Status: RL (released | freigegeben | valide) printed: 24.05.2023

**ATEX/IECEx m cable version**

**Note:**

The maximum medium temperature may never exceed the permissible temperature class (T4 135 °C, T5 100 °C, T6 85 °C) minus 5K.

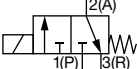
Circuit function	Port connection	Orifice	K <sub>v</sub> value water	Voltage/frequency	Coil power	Pressure range	Body material	Article no. with manual override	
		[mm]	[m <sup>3</sup> /h]	[V/Hz]	[W]	[bar]			
<b>Ex m II T4, with FKM seal and sub-base (SFB) connection with 3 m moulded cable, approved for block mounting, ambient temperature from -10 °C...+40 °C</b>									
<b>CF C</b> 3/2-way solenoid valve Direct-acting Normally closed 	Sub-base (SFB)	1.5	0.07	024/UC	7	0...10	PA	364568	
				230/UC				352017	
		Sub-base (SFB)	2.0	0.11	024/UC		7	Brass	351967
					230/UC				364570
	Sub-base (SFB)	2.0	0.11	024/UC	7	Brass	351981		
				230/UC			351990		

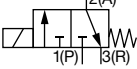
Circuit function	Port connection	Orifice	K <sub>v</sub> value water	Voltage/frequency	Coil power	Pressure range	Body material	Article no. without manual override	Article no. with manual override				
		[mm]	[m <sup>3</sup> /h]	[V/Hz]	[W]	[bar]							
<b>Ex m II T4, with FKM seal and threaded connection with 3 m moulded cable, approved for single mounting, ambient temperature from -10 °C...+55 °C</b>													
<b>CF C</b> 3/2-way solenoid valve Direct-acting Normally closed 	G 1/8	2.0	0.11	024/UC	9	0...10	Brass	351966	351979				
				230/UC				351982	352034				
				G 1/4	0.11		024/UC	9	Stainless steel	351988	X		
							230/UC			352026	X		
	G 1/8	2.5	0.16	024/UC	9	0...10	Brass	351969	351970				
				230/UC				351978	352006				
				G 1/4	0.16		024/UC	9	Stainless steel	351963	X		
							230/UC			352002	X		
	G 1/4	0.16	0.16	024/UC	9	0...6	Brass	X	X				
				230/UC				X	X				
				G 1/8	1.5		0.07	024/UC	9	0...7	Brass	351995	352000
								230/UC				364572	X
G 1/8	1.5	0.07	024/UC	9	0...7	Brass	364573	X					
			230/UC				X	X					
			G 1/4	0.07		024/UC	9	Stainless steel	352009	X			
						230/UC			351989	X			
G 1/4	0.07	0.07	024/UC	9	0...7	Brass	X	X					
			230/UC				X	X					
			G 1/8	1.5		0.07	024/UC	9	0...7	Stainless steel	351994	X	
							230/UC				X	X	

X: on request

DTS 1000011035 EN Version: T Status: RL (released | freigegeben | valide) printed: 24.05.2023

**ATEX/IECEx m terminal box version**

**Note:**

The maximum medium temperature may never exceed the permissible temperature class (T4 135 °C, T5 100 °C, T6 85 °C) minus 5K.

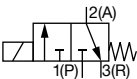
Circuit function	Port connection	Orifice	K <sub>v</sub> value water	Voltage/frequency	Coil power	Pressure range	Body material	Article no. with manual override	
		[mm]	[m <sup>3</sup> /h]	[V/Hz]	[W]	[bar]			
<b>Ex m II T4, with FKM seal and sub-base (SFB), approved for block mounting, ambient temperature from -10 °C...+40 °C</b>									
<b>CF C</b> 3/2-way solenoid valve Direct-acting Normally closed 	Sub-base (SFB)	1.5	0.07	024/UC	7	0...10	PA	352062	
				230/UC				364576	
		Sub-base (SFB)	2.0	0.11	024/UC		7	Brass	X
					230/UC				X
	Sub-base (SFB)	2.0	0.11	024/UC	7	0...6	Brass	X	
				230/UC				X	

X: on request

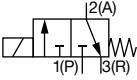
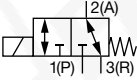
Circuit function	Port connection	Orifice	K <sub>v</sub> value water	Voltage/frequency	Coil power	Pressure range	Body material	Article no. without manual override	Article no. with manual override			
		[mm]	[m <sup>3</sup> /h]	[V/Hz]	[W]	[bar]						
<b>Ex m II T4, with FKM seal and threaded connection, approved for single mounting, ambient temperature form -10 °C...+55 °C</b>												
<b>CF C</b> 3/2-way solenoid valve Direct-acting Normally closed 	G 1/8	2.0	0.11	024/UC	9	0...10	Brass	352001	351983			
				230/UC				352005	364614			
				G 1/4	0.11		024/UC	9	0...10	Brass	351998	X
							230/UC				364581	X
	G 1/8	2.5	0.16	024/UC	9	0...6	Brass	351992	351980			
				230/UC				364587	352071			
	G 1/4	0.16	024/UC	9	0...6	Brass	352067	X				
			230/UC				352041	X				
	G 1/8	2.5	0.16	024/UC	9	0...6	Brass	364595	X			
				230/UC				364598	X			
	G 1/4	0.16	024/UC	9	0...6	Brass	364600	364615				
			230/UC				364603	364618				
<b>CF T</b> 3/2-way solenoid valve Direct-acting Flow direction optional Normally closed 	G 1/8	1.5	0.07	024/UC	9	0...7	Brass	364606	X			
				230/UC				X	X			
				G 1/4	0.07		024/UC	9	0...7	Brass	X	X
							230/UC				X	X
	G 1/8	1.5	0.07	024/UC	9	0...7	Stainless steel	X	X			
				230/UC				X	X			
	G 1/4	0.07	024/UC	9	0...7	Stainless steel	X	X				
			230/UC				364610	X				
G 1/8	1.5	0.07	024/UC	9	0...7	Stainless steel	X	X				
			230/UC				364611	X				

X: on request

DTS 1000011035 EN Version: T Status: RL (released | freigegeben | valide) printed: 24.05.2023

**ATEX/IECEX ia version**

**Note:**

The maximum medium temperature may never exceed the permissible temperature class (T4 135 °C, T5 100 °C, T6 85 °C) minus 5K.

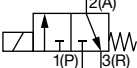
Circuit function	Port connection	Orifice	Q <sub>Nn</sub> value air	Pressure range	Body material	Article no.
		[mm]	[l/min]	[bar]		
<b>Ex ia II T6 with FKM seal only for approved single mounting, cable plug acc. to DIN EN 175 301 - 803 form A, ambient temperature from -10 °C...+60 °C for T6, -10 ... -75 °C for T5</b>						
<b>CF C</b> 3/2-way solenoid valve Direct-acting Normally closed 	Bürkert sub-base (SFB)	0.9	30	Vac. to 10	Stainless steel	20003982
	G 1/8					394532
	Bürkert sub-base (SFB)				Brass	394531
	G 1/8					394530

Further versions on request	
<b>Additional</b> Orifice: 1.2 mm, 3.0 mm	<b>Process connection</b> Banjo bolt
<b>Approval</b> UL, CSA	<b>Voltage</b> Non-standard voltages
<b>Material</b> Epoxy coil according to form A Seal material EPDM	

**9.4. Ordering chart accessories**

**Singel manifold**

**Note:**

Detailed ordering information can be found in chapter **"5.6. Single manifold"** on page 13.

**Multiple manifold**

**Note:**

Detailed ordering information can be found in chapter **"5.7. Multiple manifold"** on page 14.

**Cable plug Type 2518, form A according to DIN EN 175301 - 803**

**Note:**

For further versions see data sheet **Type 2518** ▶.

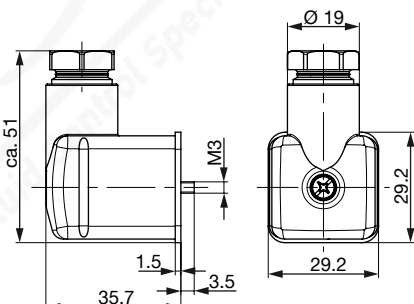
Cable plug	Dimensions	Version	Voltage	Article no.
		Without circuitry (AC/DC)	0...250 V AC/DC	314802
		With LED (AC/DC)	12...24 V AC/DC	314812
		With LED and varistor (AC/DC)	12...24 V AC/DC	314820
		With rectifier, LED and varistor	12...24 V AC/DC	314816



**Cable plug Type 2513, form A according to DIN EN 175301 - 803**

**Note:**

- Cable plug Type 2513 meets the requirements of ATEX category 3 GD when assembled with a Bürkert solenoid valve.
- For more information on the cable plug, see data sheet **Type 2513** ▶.

Cable plug	Circuit diagram	Cable length [mm]	Article no.
		12000	260893
		5000	260892
		3000	260891
		300	260890

**Cable glands for ATEX/IECEx terminal box**

**Note:**

- A cable gland in polyamide version is included in the delivery. A nickel-plated brass version can be ordered at surcharge.
- For more information on Ex cable glands, see **“8.1. Cable glands for ATEX/IECEx terminal box” on page 17.**

Description	Article no.
Ex cable gland, brass, nickel-plated, 6...13 mm <sup>1.)</sup>	773278
Ex cable gland, polyamide, 7...13 mm <sup>1.)</sup>	773277
Set SC02-AC10: Special wrench <sup>2.)</sup> incl. service manual	293488

1.) Cable diameter

2.) Not included in the scope of delivery of the valve

DTS 1000011035 EN Version: T Status: RL (released | freigegeben | validé) printed: 24.05.2023