



2/2-way Angle-Seat Valve with NPT ends for media up to 356 °F (180 °C) 1/2" – 2 1/2"

- High flow rates
- Very high cycle life
- Long life alternative to ball valves
- Threaded end body
- Suitable for 150 PSI steam
- Deliverable with flow direction below or above seat
- Normally closed, normally open; or double-acting

Type 2000 Angle-Seat can be combined with...



Type 8690

Pneum. control unit with feedback



Type 8697

Electrical position feedback

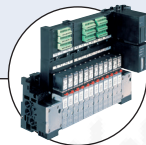

Type 8640/8644

Valve block



Type 6012/6014 P

Pilot valve

The externally piloted angle-seat valve is operated with a single or double-acting piston actuator. The actuator is available in two different materials, PA and PPS depending on the ambient temperature. The reliable self-adjusting packing gland provides high sealing integrity. High flow rates are attained with the gunmetal or cast stainless steel 2-way body. These maintenance-free and robust valves can be retrofitted with a comprehensive range of accessories for position indication, stroke limitation or manual override.

For valves with port connection clamp and weld end please see separate datasheets.

¹⁾ **Note:** For PA actuators in the sizes 40, 50 and 63, the combination of max. medium temperature and max. ambient temperature is as shown in the following chart

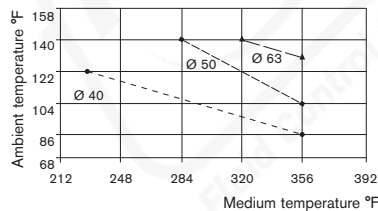

Technical data	
Orifice	1/2" to 2 1/2" (DN 13 to 65)
Body materials	Gunmetal, cast stainless steel 316L
Actuator material	PA or PPS
Seal material	PTFE (NBR, FKM and EPDM on request)
Medium	Water, alcohol, oils, fuel, hydraulic fluids, salt solution, alkali solutions, organic solvents, steam
Viscosity	max. 600 mm ² /s
Packing gland (with silicone grease)	PTFE V-rings with spring compensation
Medium temperature¹⁾	14 °F to 356 °F (-10 °C to +180 °C) with PTFE seal
Ambient temperature	
PA actuator ¹⁾	14 °F to 140 °F (-10 °C to +60 °C)
PPS actuator ¹⁾ Ø 40-80	41 °F to 284 °F (+5 °C to +140 °C)
PPS actuator ¹⁾ Ø 100-125	41 °F to 194 °F (+5 °C to +90 °C), briefly up to 284 °F (+140 °C)
Installation	As required, preferably with actuator in upright position
Control medium	Neutral gases, air
Max. pilot pressure	
Actuator size Ø 40 - 80	PA and PPS 145 PSI
Actuator size Ø 100	PA 145 PSI
Actuator size Ø 100	PPS 100 PSI
Actuator size Ø 125	PA and PPS 100 PSI
Port connection	G 3/8 to G 2 1/2 (NPT on request)

Content



Valve specifications

Type 2000 threaded port

Technical data & ordering info.

p. 1-8



System spec. On/Off Classic

Type 8801-YA/
8803-YA

Ordering info. & technical data

p. 9-11

Request for quotation

Type 8801-YA/
8803-YA

p. 12

Materials Type 2000 threaded port

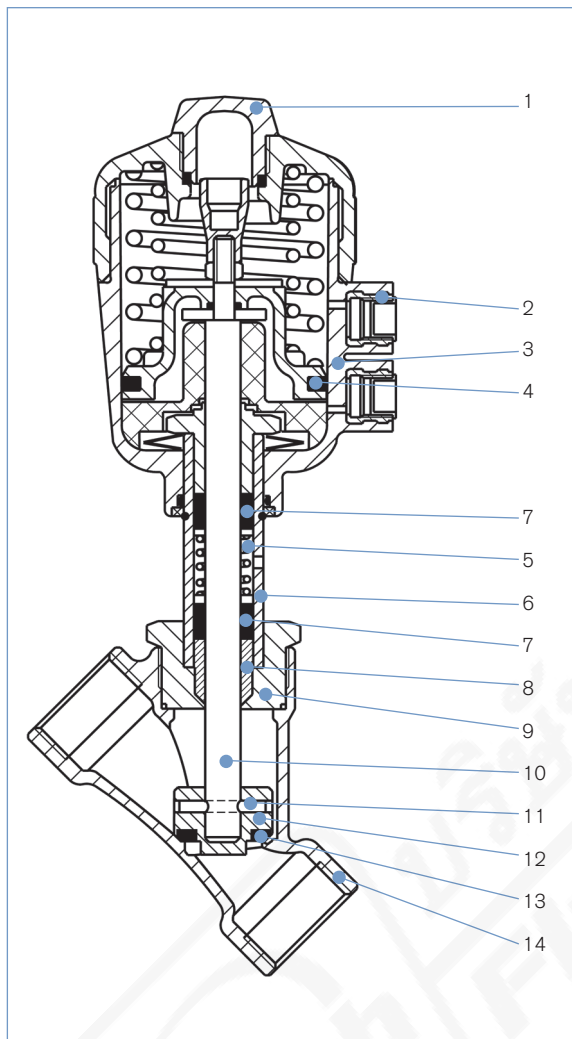

	Gunmetal body	Cast stainless steel body
1 Transparent cap	PC (with PPS actuator; PSU)	PC (with PPS actuator; PSU)
2 Pilot air ports	Brass	Stainless steel 1.4305
3 Actuator	PA, PPS	PA, PPS
4 Piston seal	NBR (with PPS actuator; FKM)	NBR (with PPS actuator; FKM)
5 Spring	Stainless steel 1.4310	Stainless steel 1.4310
6 Tube	Brass CuZn39Pb3	Stainless steel 1.4401
7 V-Seals	PTFE (FKM on request)	PTFE (FKM on request)
8 Wiper	PTFE	PTFE
9 Nipple	Brass CuZn	Stainless steel 1.4401
10 Spindle	Stainless steel 1.4021	Stainless steel 1.4401
11 Pin	Stainless steel 1.4401	Stainless steel 1.4401
12 Swivel plate	Brass CuZn36Pb1.5	Stainless steel 1.4401
13 Seal	PTFE (NBR, FKM, EPDM on request)	PTFE (NBR, FKM, EPDM on request)
14 Valve body	Gunmetal GCuSn5ZnPb2%Ni	Stainless steel 316L

DTS 1000082408 EN Version: M Status: RL (released | freigegeben | validé) printed: 08.11.2021

Dimensions [mm]

DN Orifice	Threaded Port Body				All bodies			
	Ø D	A	B	C	Actuator size Ø	H	E Ø	P
13/15	NPT 1/2	65	163	10.3	50	140	64	G 1/4
20	NPT 3/4	75	171	14	50	144	64	G 1/4
			198	14	63	171	80	
25	NPT 1	90	181	16.8	50	152	64	G 1/4
			206	16.8	63	177	80	
			228	16.8	80	198	101	
32	NPT 1 1/4	110	219	17.3	63	183	80	G 1/4
			240	17.3	80	205	101	
			292	17.3	100	255	127	
40	NPT 1 1/2	120	222	17.3	63	188	80	G 1/4
			244	17.3	80	209	101	
			295	17.3	100	260	127	
			324	17.3	125	289	153	
50	NPT 2	150	250	20	63	205	80	G 1/4
			270	20	80	225	101	
			316	20	100	271	127	
			346	20	125	301	153	
65	NPT 2 1/2	185	296	22	80	239	101	G 1/4
			344	22	100	287	127	
			372	22	125	315	153	

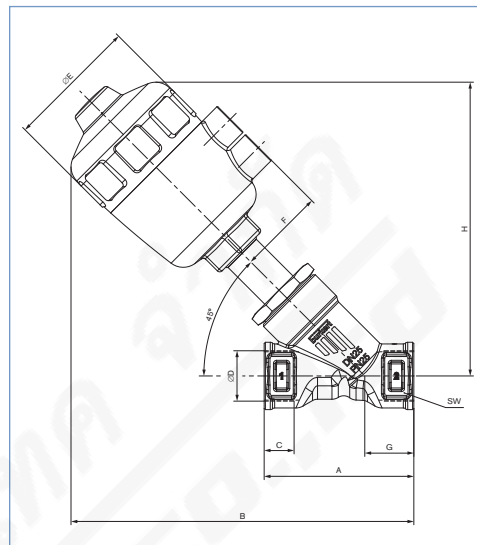

Ordering chart for valves with FLOW DIRECTION BELOW SEAT
Actuator material PA (polyamide) with threaded port

Control function	Orifice	Port Connection Threaded port NPT	Actuator size Ø [mm]	C _v value	Operating pressure up to 365 °F [PSI]	Minimum pilot pressure [PSI]	Item no. Bronze body	Item no. St. st. body
A 2/2-way, NC by spring action Normally closed	1/2" (13)	1/2	50	4.9	232	56.5	463 571	463 613
			63	10.4	232	65.3	463 573	463 615
	3/4" (20)	3/4	50	9.9	160	56.5	463 572	463 614
			63	20.9	160	65.3	463 574	463 616
	1" (25)	1	63	20.9	232	72.5	463 575	463 617
			80	20.9	87	65.3	464 576	464 577
	1 1/4" (32)	1 1/4	63	29.0	87	65.3	464 576	464 577
			80	31.3	203	72.5	463 576	463 618
	1 1/2" (40)	1 1/2	80	44.1	130	72.5	463 577	463 619
			100	46.4	181	63.8	464 014	464 015
125			46.4	232	46.4	463 578	463 620	
2" (50)	2	100	63.8	104	63.8	454 610	454 624	
		125	63.8	145	46.4	454 785	454 789	
		104.4	104.4	75	46.4	454 611	454 625	
2 1/2" (65)	2 1/2	125	104.4	104.4	150	72.5	462 656	462 657
			150	150	72.5	462 656	462 657	

B 2/2-way valve, open by spring force, available on request
Other pressure ranges, circuit functions, flow from above, PPS actuators and accessories available on request

DTS 1000082408 EN Version: M Status: RL (released | freigegeben | validé) printed: 08.11.2021

Technical data

Flow direction above seat (only for gases and steam)	
Media	Gaseous media and steam
Other technical data	Please see information for flow direction below seat
Attention!	Valves with flow direction above seat are only conditionally usable for liquid media. There is a danger of waterhammer!

Ordering chart for valves WITH FLOW DIRECTION ABOVE THE SEAT

Actuator material PA (polyamide) with pilot pressure depending on operating pressure according to Charts 1 and 2

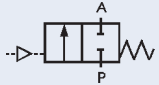
Control function	Orifice	Port Connection Threaded port NPT	Actuator size Ø [mm]	C _v value	Operating pressure up to 365 °F [PSI]	Item no. bronze body media inserts	Item no. St. st. body
A 2/2-way, NC by spring action  Normally closed	1/2" (13)	1/2	50	4.9	232	463 585	463 627
	3/4" (20)	3/4	50	9.9	232	463 587	463 629
	1" (25)	1	63	20.9	232	463 589	463 631
	1 1/4" (32)	1 1/4	63	29	232	463 590	463 632
	1 1/2" (40)	1 1/2	63	40.6	232 ¹⁾	463 591	463 633
			80	44.1	232	464 578	464 579
	2" (50)	2	63	56.8	232 ¹⁾	454 632	454 641
			80	60.3	232 ¹⁾	454 633	454 642
2 1/2" (65)	2 1/2	80	89.3	203 ¹⁾	454 634	454 643	

¹⁾ Pilot pressure >80 PSI at maximum system pressure.

Other pressure ranges, circuit functions, PPS actuators and accessories on request

Pressure charts 1 and 2 with circuit function A and flow direction above the seat (air pressure required to lift off the seat)

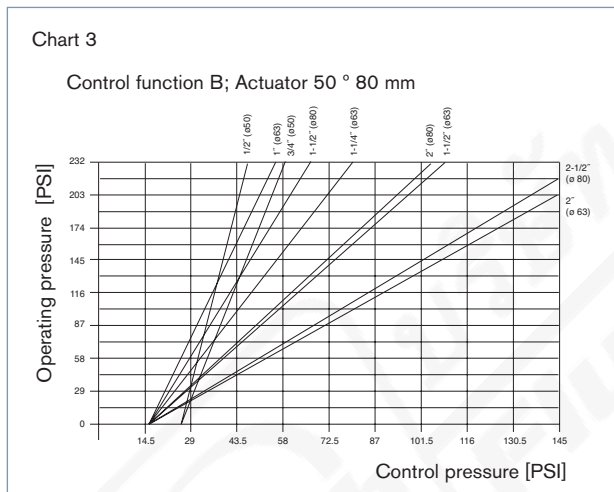
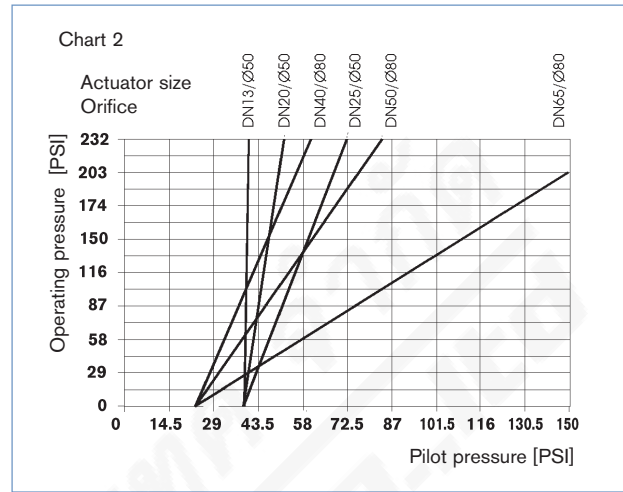
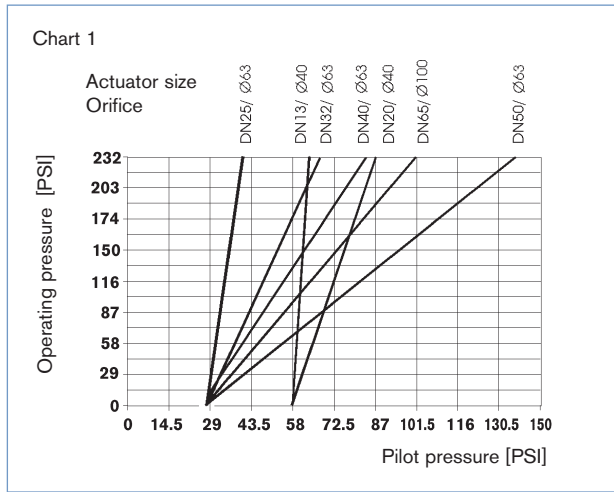

Pilot valve according to actuator size	Voltage	Item no.
3/2-way pilot valves Type 6012 P/6014 P with banjo mounting; 1/4" NPT customer air connection		
Type 6012 P for actuator Ø 50 and 63 mm	024 V/DC	428 565
$C_v = .05$	120 VAC/60 Hz	428 567
Type 6014 P for actuator Ø 50 to 125 mm	024 V/DC	429 134
$C_v = .13$	120 VAC/60 Hz	429 136

Fitting type	Shape	Material	Item no.
Male G 1/4 x 1/4 NPT female	Straight	Nickel plated brass	98162754
Male G 1/4 x 1/4" tube push connection	Swivel elbow	Nickel plated brass	98163251

Options and accessories (on request)

- Circuit function I (double-acting actuator) and B (spring-return normally-open)
- PPS actuator
- Electrical position feedback, Type 1060 and 1062
- Magnetic-inductive proximity sensors, Type 1071
- Stroke limitation max. and min./max.
- Manual actuator
- NAMUR adapter for pilot valves

Note: Please request the Accessories data sheet 2000 (Accessories for valve series 2000 – 2031).

Technical data

Ordering chart for valves WITH FLOW DIRECTION BELOW THE SEAT, NORMALLY OPEN

Actuator material PA (polyamide) with pilot pressure depending on operating pressure according to Chart 3

Control function	Orifice	Port Connection Threaded port NPT	Actuator size Ø [mm]	C _v value	Operating pressure up to pressure up to 365°F [PSI]	Item no. bronze body	Item no. St. st. body
B 2/2-way, NO by spring action	1/2" (13)	1/2	50	4.9	232	463 580	463 622
	3/4" (20)	3/4	50	9.9	232	463 581	463 623
Normally open	1" (25)	1	63	20.9	232	464 494	464 506
	1 1/4" (32)	1 1/4	63	29.0	232	463 583	463 625
	1 1/2" (40)	1 1/2	63	40.6	232 ¹⁾	463 584	463 626
			80	44.1	232	464 016	464 017
	2" (50)	2	63	56.8	188 ¹⁾	454 617	454 602
			80	60.3	232 ¹⁾	454 787	454 791
2 1/2" (65)	2 1/2	80	89.3	217 ¹⁾	454 618	454 603	

¹⁾ Pilot pressure >80 PSI at maximum system pressure.

Other pressure ranges, circuit functions, PPS actuators and accessories on request

Connections NPT	Orifice [inch]	C _v	Max. Operating Pressure ²⁾ } → Differential Pressure ¹⁾		Required Control Pressure CFA [PSI]	Weight [lbs.]	Actuator Size [mm] ø DIA			
			CFA [PSI]	CFB [PSI]						
1/2	1/2"	4.9	232		56	1.8	50			
				232			50			
3/4	3/4"	9.9	160		56	2.2	50			
				232			50			
1	1"	20.9	160		65	4.0	63			
				232			63			
1 1/4	1 1/4"	31.3	203		73	6.8	80			
				232			63			
				29.0			4.9	63		
1 1/2	1 1/2"	44.1	130		73	7.7	80			
				232			63			
				46.4			181	64	12.4	100
				44.1			232	7.7	80	
2	2"	63.8	104		64	15.4	100			
				56.8			188	8.8	63	
				63.8			145	47	20.7	125
				60.3			232	10.6	80	
2 1/2	2 1/2"	104.4	150		73	24.3	125			
				89.3			217	14.1	80	

¹⁾ Higher differential pressures by other combinations of actuators on request.²⁾ Max. operating pressure with steam -> 150 PSI (365°F).

Ordering chart for valves

Ordering chart for valves WITH FLOW DIRECTION ABOVE THE SEAT, High temperature version, steam @ 150 PSI
Actuator material PPS (polyphenylsulfide) with pilot pressure depending on operating pressure according to Charts 1 and 2

Control function	Orifice	Port Connection Threaded port NPT	Actuator size Ø [mm]	C _v value	Pilot air pressure @ 150 PSIG line pressure	Item no. bronze body	Item no. St. st. body
A 2/2-way, NC by spring action	1/2" (13)	1/2	50	4.9	<60	463 606	463 648
	3/4" (20)	3/4	50	9.9	<60	463 607	463 649
	1" (25)	1	63	20.9	<60	463 609	463 651
	1 1/4" (32)	1 1/4	63	29.0	<60	463 610	463 652
	1 1/2" (40)	1 1/2	63	40.6	66	463 611	463 653
	2" (50)	2	80	60.3	66	457 368	460 434
	2 1/2" (65)	2 1/2	100	104.4	78	462 743	462 742

Angle seat valve spare part sets (kits contain a valve seat or sealing seat set; see drawing)

SET 6 valve seat kit, 2/2-way valve with bronze body

DN	Item no. PTFE seal	Item no. FKM seal
1/2" (13)	010 984	011 065
3/4" (20)	010 986	011 070
1" (25)*	010 988	011 085
1" (25)**	159 635	-
1 1/4" (32)	011 044	011 088
1 1/2" (40)	011 046	011 107
2" (50)	011 390	011 109
2 1/2" (65)	011 064	011 120

SET 6 valve seat kit, 2/2-way valve with stainless steel body

DN	Item no. PTFE seal	Item no. FKM seal
1/2" (13)	011 134	011 234
3/4" (20)	011 171	011 253
1" (25)*	011 202	011 259
1" (25)**	160 737	-
1 1/4" (32)	011 208	011 262
1 1/2" (40)	011 209	011 267
2" (50)	011 214	011 269
2 1/2" (65)	011 216	011 307

* Actuator size 50, Letter code D.

** Actuator size 63/80, Letter code E/F.

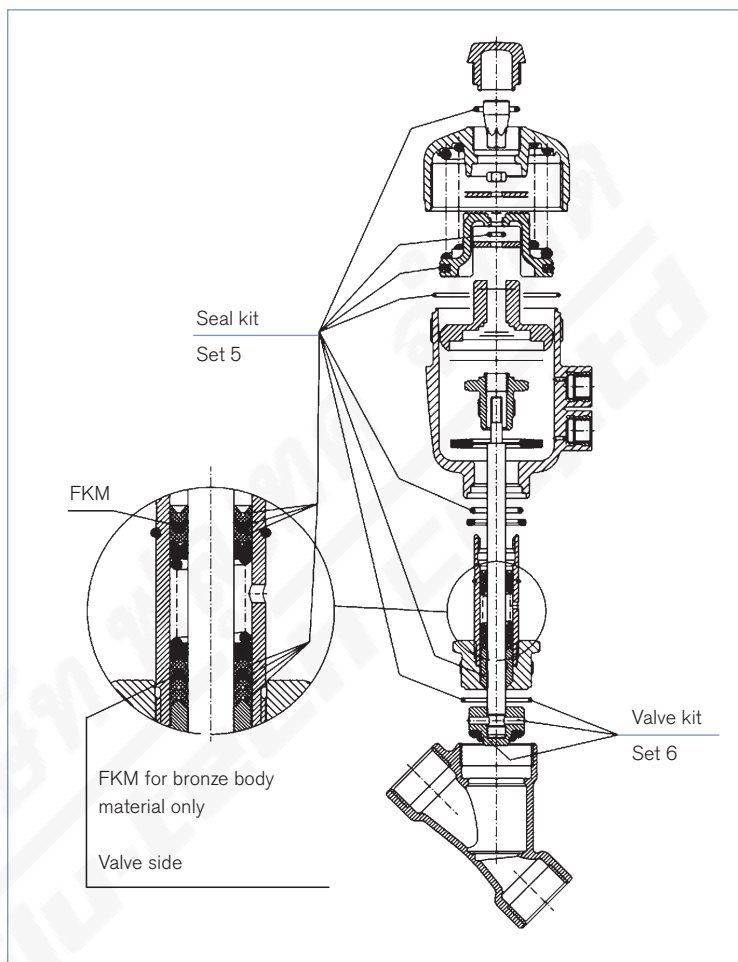

SET 5 Sealing set for PA-actuator

Actuator size Ø	For Valve sizes	Item no. bronze body	Item no. stain-less steel body
C 1 1/2" (40)	DN 13/20	643 438	643 438
D 2" (50)	DN 13/20/25	011 308	011 369
E 2 1/2" (63)	DN 25 - 50	011 334	011 372
F 3" (80)	DN 25 - 65	011 366	001 902
G 4" (100)	DN 32 - 65	007 763	011 386
H 5" (125)	DN 40 - 65	011 368	011 387

Set 5 sealing set for PPS-actuator

Actuator sizes Ø	For Valve sizes	Item no. bronze body	Item no. stain-less steel body
C 1 1/2" (40)	DN 13/20	643 536	643 536
D 2" (50)	DN 13/20/25	011 373	011 388
E 2 1/2" (63)	DN 25 - 50	007 765	007 766
F 3" (80)	DN 25 - 65	011 375	007 767
G 4" (100)	DN 32 - 65	011 374	011 389
H 5" (125)	DN 40 - 65	007 764	007 768

DTS 1000082408 EN Version: M Status: RL (released | freigegeben | validé) printed: 08.11.2021

Ordering information for valve system On/Off Classic Type 8801-YA/8803-YA

A valve system On/Off Classic Type 8801-YA/8803-YA consists of an angle-seat valve Type 2000 and a pneumatic control unit Type 8690 or an electrical position feedback Type 8697 (see separate datasheets).

For the configuration of further valve systems please use the "Request for quotation" on page 12 [go to page](#)

You order two components and receive a complete assembled and certified valve.

Ordering the valve system On/Off Classic Type 8801-YA/8803-YA

Angle-seat valve Type 2000 threaded port



Control units



Angle-seat valve with desired control unit

For port connections weld end and clamp, see separate datasheets



When you click on the orange box "More info." below, you will come to our website for the resp. product where you can download the datasheet.

Pneumatic control unit Type 8690



The new generation of integrated controllers for combination with actuators from the process valve series Type 20xx/21xx is specially designed for the requirements of hygienic process environments.

The pneumatic control unit Type 8690 combines electrical position feedback and pneumatic control for single or double-acting actuators, and is also optionally available as an intrinsically safe model to ATEX.

Main customer benefits:

- Integrated pilot valve with manual actuation
- Air intake filter enhances the process valve system availability
- Simple and reliable actuator adaptations allowing additional actuators of the process valve series, Type 20xx or actuators from other manufacturers to be used

More info.

Electrical Position Feedback Type 8697



The position feedback Type 8697 is designed for integrated mounting on CLASSIC series 20XX process valves suiting the requirements of hygienic process environment. Mechanical or inductive limit switches register the position of the valve.

Features

- Compact design
- LED position indicator
- Mechanical or inductive limit switches for end position registering
- Easy to clean chemically resistant housing featuring IP65/IP67, 4X Rating
- Optional intrinsically safe version acc. to ATEX

Customer benefits

- Easy and quick installation
- High level of signal reliability thanks to self adjusting limit switches
- Minimized space requirement in the plant piping for more flexibility in plant design

More info.

Dimensions for valve system On/Off Classic Type 8801-YE-K [mm]

Dimensions valve system On/Off Classic Type 8801-YA-K with TopControl Type 8690 [mm]

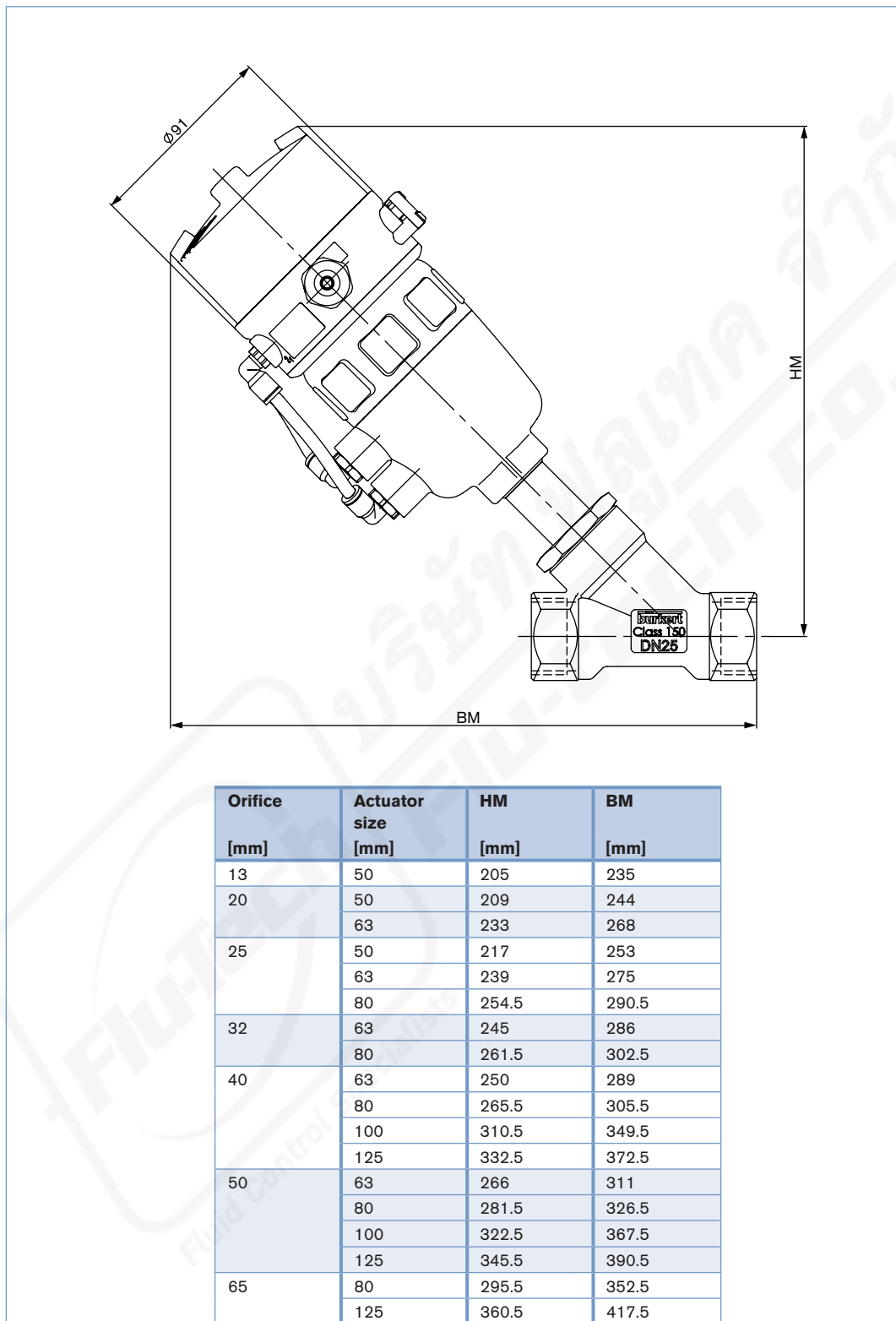

DTS 1000082408 EN Version: M Status: RL (released | freigegeben | validé) printed: 08.11.2021

Dimensions

Angle seat valve Type 2000 and valve system On/Off CLASSIC Type 8801-YA [mm]

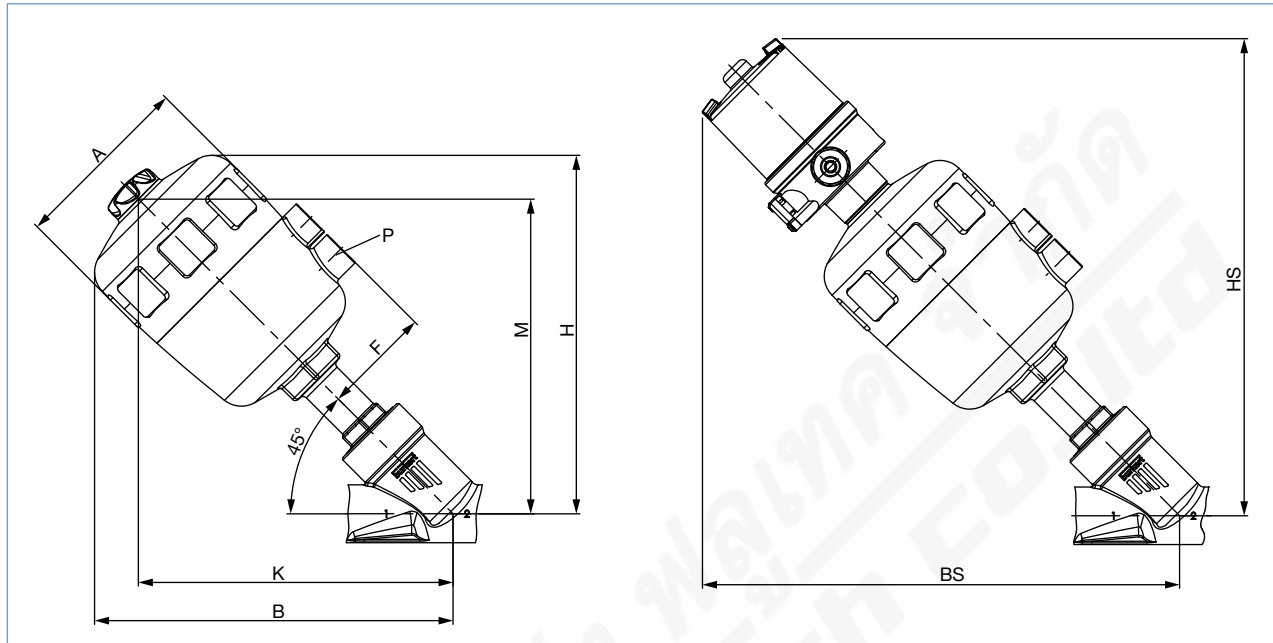

Nominal diameter (pipe)		Actuator size Ø	Ø A	B / H ^{1.)}	K / M ^{1.)}	P	BS / HS ^{1.)}
DN	NPS		[mm]	[mm]	[mm]	[inch]	[mm]
10	¾	40(C)	53	127	110	G ⅛	198
		50(D)	64	145	129	G ¼	216
		63(E)	80	177	158	G ¼	246
15	½	40(C)	53	127	110	G ⅛	198
		50(D)	64	145	129	G ¼	216
		63(E)	80	177	158	G ¼	246
20	¾	40(C)	53	130	113	G ⅛	201
		50(D)	64	150	133	G ¼	207
		63(E)	80	174	155	G ¼	243
		80(F)	101	195	171	G ¼	259
25	1	50(D)	64	152	136	G ¼	223
		63(E)	80	178	159	G ¼	242
		80(F)	101	195	171	G ¼	259
32	1¼	63(E)	80	188	169	G ¼	257
		80(F)	101	209	185	G ¼	273
		100(G)	127	262	232	G ¼	320
		125(H)	158	306	269	G ¼	357
40	1½	63(E)	80	191	172	G ¼	260
		80(F)	101	213	188	G ¼	277
		100(G)	127	251	221	G ¼	309
		125(H)	158	291	254	G ¼	342
50	2	63(E)	80	209	190	G ¼	278
		80(F)	101	230	206	G ¼	294
		100(G)	127	277	247	G ¼	335
		125(H)	158	306	269	G ¼	357
65	2½	80(F)	101	242	218	G ¼	306
		100(G)	127	290	260	G ¼	348
		125(H)	158	319	282	G ¼	370
		125(H)	158	339	301	G ¼	390
80	3	125(H)	158	339	301	G ¼	390

1.) Dimensions for B, H, K, M, HS and BS are maximum dimensions and can be up to 6 mm smaller depending on the nominal diameter and port connection.

Note
You can fill out the fields directly in the PDF file before printing out the form.

Valve system On/Off Classic Type 8801-YA/8803-YA – request for quotation

▶ Please fill out and send to your nearest Burkert facility* with your inquiry or order

Company	Contact person
Customer no.	Department
Address	Tel./Fax
Postcode/town	E-Mail

= mandatory fields to fill out Quantity Required delivery date

Operating data

Pipeline	DN	<input type="text"/>	PN	<input type="text"/>
Pipe material	<input type="text"/>			
Process medium	<input type="text"/>			
Type of medium	<input type="checkbox"/> Liquid	<input type="checkbox"/> Steam	<input type="checkbox"/> Gas	
	standard	unit		
Flow rate (Q, Q _N , W) ¹⁾	<input type="text"/>	<input type="text"/>		
Temperature at valve inlet	<input type="text"/>			
Absolute pressure at valve inlet	<input type="text"/>			

¹⁾ standard unit: Liquid Q = m³/h; Steam W = kg/h; Gas Q_N = Nm³/h

Valve features

Actuator material	<input type="checkbox"/> PA	<input type="checkbox"/> PPS
Body material	<input type="checkbox"/> Stainless steel	<input type="checkbox"/> Gunmetal
Seat sealing material	<input type="checkbox"/> PTFE <input type="checkbox"/> NBR	<input type="checkbox"/> Other <input type="text"/>
Nominal pressure	PN <input type="text"/>	
Nominal size	DN <input type="text"/>	
Type of connection	<input type="checkbox"/> Welded <input type="checkbox"/> Internal thread <input type="checkbox"/> Clamp	
Standard connection	<input type="checkbox"/> ISO <input type="checkbox"/> DIN <input type="checkbox"/> ANSI <input type="checkbox"/> JIS <input type="checkbox"/> Other <input type="text"/>	
Function	<input type="checkbox"/> NC ²⁾ <input type="checkbox"/> NO ²⁾ <input type="checkbox"/> Double-acting	
Pilot pressure	<input type="text"/> min.	<input type="text"/> max.

²⁾ NC: normally closed by spring action; NO: normally open by spring action

Control unit features

Control Head	Electrical position feedback
<input type="checkbox"/> Type 8690	<input type="checkbox"/> Type 8697
Pneumatic function	Electrical connection
<input type="checkbox"/> Single-acting <input type="checkbox"/> Double-acting	<input type="checkbox"/> Cable gland <input type="checkbox"/> M12 connector ¹⁾
<input type="checkbox"/> Without pilot valve	Number of end position feedback switches
Position feedback	2x Micro or inductive <input type="text"/>
<input type="checkbox"/> 1x inductive <input type="checkbox"/> 2x inductive	Approvals
<input type="checkbox"/> 1x inductive (NAMUR) <input type="checkbox"/> 2x inductive (NAMUR)	<input type="checkbox"/> ATEX cat. 3GD, IECEx
<input type="checkbox"/> 1x mechanical <input type="checkbox"/> 2x mechanical	<input type="checkbox"/> ATEX cat. 2DG, IECEx
Supply voltage	<input type="checkbox"/> Without
<input type="checkbox"/> 24 V / DC (ATEX Zone 2/22)	Position feedback switch
<input type="checkbox"/> Ex ia IIC T6 (ATEX Zone 1)	<input type="checkbox"/> Micro switch 24 V DC
Pilot air ports	<input type="checkbox"/> Inductive switch 2-wire NAMUR
<input type="checkbox"/> Push-in connector <input type="checkbox"/> Thread G 1/8"	<input type="checkbox"/> Micro switch 50...225 V DC/AC
external ø 6 mm or 1/4"	<input type="checkbox"/> Inductive switch 2-wire 24 V DC
Please specify item no. if known:	<input type="checkbox"/> Inductive switch 3-wire PNP
<input type="text"/>	<input type="checkbox"/> Without

¹⁾ Applicable only with inductive switch 3-wire PNP

Reset form

continued on next page →

DTS 1000082408 EN Version: M Status: RL (released | freigegeben | validé) printed: 08.11.2021

Valve system On/Off Classic Type 8801-YA/8803-YA – request for quotation, *continued*

Control unit features	
Pilot valve <input type="checkbox"/> Pilot valve	Stroke limitation <input type="checkbox"/> Stroke limitation
Power supply <input type="text"/>	<input type="checkbox"/> Min./max. stroke limitation , with visual position indicator <input type="checkbox"/> Max. stroke limitation , without visual position indicator
Please specify item no. if known: <input type="text"/>	Please specify item no. if known: <input type="text"/>

Certifications
<input type="checkbox"/> Attestation of compliance with the order EN-ISO 10204 2.1
<input type="checkbox"/> Test report EN-ISO 10204 2.2
<input type="checkbox"/> Certification of Conformity for Raw Material EN-ISO 10204 3.1
<input type="checkbox"/> EN161 (European Gas Device guideline)

Comment / sketch

[Reset form](#)

DTS 1000082408 EN Version: M Status: RL (released | freigegeben | validé) printed: 08.11.2021