





Inductive conductivity meter, ELEMENT Design

- Perfect for concentrated liquids and wide conductivity ranges
- Pre-parameterized variants available for direct start-up
- Measurement device for direct connection to the monitoring level (PLC) via analogue 4...20 mA signal or digital IO-Link or Bürkert system bus (büS)/CANopen communication
- Simulation of process values for diagnostics
- Variants of the sensor available in PP, PVDF or PEEK

Product variants described in the data sheet may differ from the product presentation and description.

Can be combined with

- 

Type S020 ▶
Insertion fitting for flow or analytical measurement
- 

Type 8611 ▶
eCONTROL - Universal controller
- 

Type 8619 ▶
multiCELL - Multi-channel and multi-function transmitter/controller
- 

Type 8693 ▶
Digital electro-pneumatic process controller for integrated mounting on process control valves
- 

Type 8802 ▶
ELEMENT continuous control valve systems - overview

Type description

The Bürkert inductive Type 8228 conductivity meter is used in many industrial processes where measurements are required in aggressive or concentrated media such as acids, alkalis or liquids with high salt contents and a wide measuring range.

This can concern applications like cooling water monitoring (i.e. dilution control), industrial water treatment or the preparation and identification of cleaning liquids, for example in CIP processes.

The device Type 8228 is available in two variants.

The first one, the so-called ELEMENT standard is proposed either with two adjustable outputs (one digital and one analogue output) or with four adjustable outputs (two digital and two analogue outputs) and can be equipped with a display. The display is only necessary for start-up, configuration (e.g. measuring range, units, calibration, thresholds) or as a display of process values

The second variant, the so-called ELEMENT neutrino is a device without display, with a digital communication mode that can communicate either in IO-Link or in büS (Bürkert system bus based on CANopen).

Both variants are available with a process connections either via a G 2" union nut for installation into a fitting Type S020 which is connected to the process, or via a clamp 2" according to ASME BPE (clamp 1.5" on request) for CIP applications.

DTS 1000220089 EN Version: T Status: RL (released | freigegeben | validé) printed: 22.04.2024

FLU-TECH CO. LTD.

Email: sales@flutech.co.th **Website:** https://flutech.co.th

Tel: 02-384-6060, 086-369-5871-3 **Fax:** 02-384-5701 **LINE OA:** @flutech.co.th

Address (HQ): 845/3-4, Moo 3, Theparak Rd., T. Theparak, A. Mueang Samut Prakan, Samut Prakan, 10270, Thailand



Table of contents

1. General technical data	4
1.1. About the device	4
1.2. All variants.....	4
1.3. ELEMENT standard variant.....	6
1.4. ELEMENT neutrino variant.....	7
2. Approvals and conformities	8
2.1. General notes.....	8
2.2. Conformity	8
2.3. Standards.....	8
2.4. Pressure Equipment Directive (PED).....	9
Device used on a pipe	9
Device used on a vessel	9
2.5. North America (USA/Canada)	9
2.6. Foods and beverages/Hygiene	9
3. Materials	10
3.1. Bürkert resistApp	10
3.2. Material specifications	10
ELEMENT standard variant.....	10
ELEMENT neutrino variant.....	11
4. Dimensions	12
4.1. ELEMENT standard variant.....	12
With G 2" process connection	12
With G 2" process connection, installed in an Insertion fitting Type S020	12
With 2" clamp process connection.....	13
4.2. ELEMENT neutrino variant.....	14
With G 2" process connection	14
With G 2" process connection, installed in an Insertion fitting Type S020	14
With 2" clamp process connection.....	15
5. Performance specifications	15
5.1. Pressure temperature diagram.....	15
6. Product installation	16
6.1. Installation notes	16
With G 2" process connection.....	16
With 2" clamp process connection.....	16
6.2. Mounting options.....	17
7. Product operation	17
7.1. Measuring principle.....	17
7.2. Functional overview	18
Concentration table.....	18
8. Product design and assembly	19
8.1. Product assembly	19
With G 2" process connection	19
With 2" clamp process connection.....	19
9. Product accessories	20

10. Networking and combination with other Bürkert products	20
10.1. Combination with transmitter/controller and fitting	20
10.2. Combination with available Type S020 Insertion fittings DN	21
11. Ordering information	21
11.1. Bürkert eShop	21
11.2. Recommendation regarding product selection.....	21
With G 2" process connection	21
With 2" clamp process connection.....	22
11.3. Bürkert product filter	22
11.4. Ordering chart	23
ELEMENT standard variant.....	23
ELEMENT neutrino variant.....	25
11.5. Ordering chart accessories.....	26

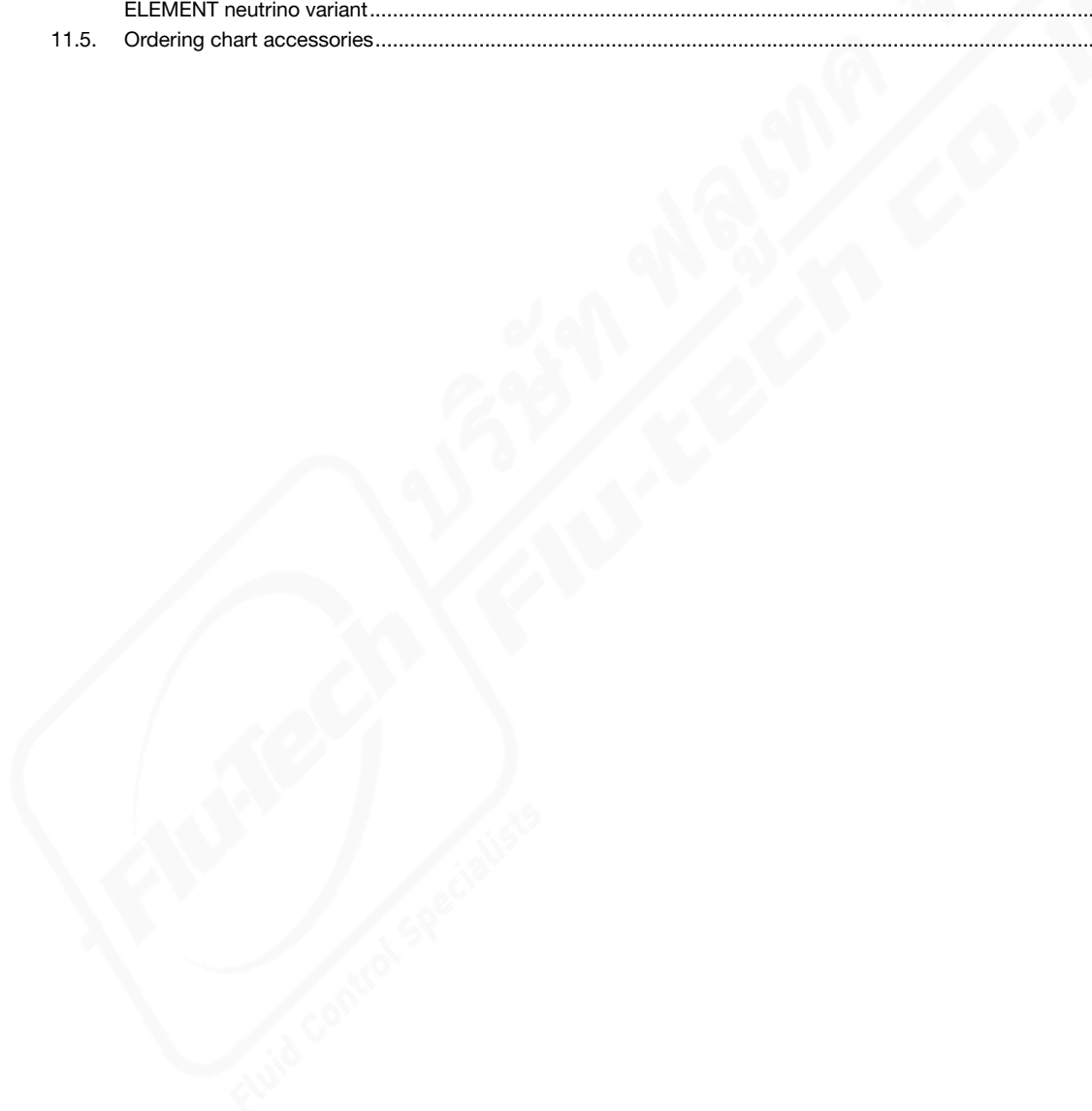

1. General technical data

1.1. About the device

The conductivity measurement device consists of a sensor fastened to the transmitter. The device is available in an ELEMENT standard variant or in an ELEMENT neutrino variant.

The process connection of both variants is made via

- a G 2" union nut (for mounting in a Type S020 fitting) for general applications
- a clamp 2" according to ASME BPE (clamp 1.5" on request) for CIP applications.

The ELEMENT standard variant is available with up to two 4...20 mA analogue outputs or with up to two transistor outputs. The ELEMENT neutrino variant is available with digital communication.

The device with digital communication is distinguished by a status indicator on the cover, and is offered with a housing in metal (so-called metallic variant) or in plastic (so-called all-plastic variant for corrosive environmental conditions like in the electronic & semiconductor industry market).

The metallic variant is provided with a digital IO-Link and bÜS (Bürkert system bus, CANopen protocol) communication, the all-plastic variant with a digital IO-Link communication (bÜS available only for service activities such as configuration or calibration).

1.2. All variants

Note:

- The following data applies to all variants mentioned above.
- If the device is mounted in a humid environment or outside, then the maximum voltage allowed is **35 V DC** instead of 36 V DC.

Product properties

Material	
Make sure the device materials are compatible with the fluid you are using. Further information can be found in chapter "3.1. Bürkert resistApp" on page 10.	
Further information on the materials can be found in chapter "3.2. Material specifications" on page 10.	
Non wetted parts	
Union nut	Variant for general applications: PC or PPA (with PEEK sensor armature)
Wetted parts	
Process connection (clamp)	Variant for CIP applications: stainless steel 1.4404 (316L)
Sensor armature	<ul style="list-style-type: none"> • Variant for general applications: PP, PVDF or PEEK • Variant for CIP applications: PEEK (standard) or PVDF (on request)
Compatibility	<ul style="list-style-type: none"> • Variant for general applications: Any pipe from DN 15...DN 200 which are fitted with Bürkert S020 Insertion fitting. Further information on the available fitting can be found in chapter "10.1. Combination with transmitter/controller and fitting" on page 20 For the selection of the nominal diameter of the Insertion sensor-fittings, see data sheet Type S020 ▶. • Variant for CIP applications: Any pipe from DN 32 which are fitted out with a clamp 2" according to ASME BPE as process connection for the device
Pipe diameter	<ul style="list-style-type: none"> • Variant for general applications: DN 15...DN 200 • Variant for CIP applications: DN ≥32
Dimensions	Further information can be found in chapter "4. Dimensions" on page 12.
Temperature sensor	Integrated in the sensor
Temperature compensation	<ul style="list-style-type: none"> • None or • According to a predefined graph (NaCl, NaOH, HNO₃ or H₂SO₄) or • According to a graph defined especially for your process
Measuring range	
Conductivity measurement	100 µS/cm...2 S/cm
Temperature measurement	-15...+130 °C (+5...+266 °F)
Concentration	<ul style="list-style-type: none"> • Conversion of conductivity to dissolved electrolyte concentration (Total dissolved solids (TDS)) by using a user adjustable factor • Determination of the concentration of certain electrolytes (NaCl, H₂SO₄, HNO₃, NaOH, HCl) as a function of conductivity and temperature

DTS 1000220089 EN Version: T Status: RL (released | freigegeben | validé) printed: 22.04.2024

Performance data

Conductivity measurement

Measurement deviation	± (2 % of the measured value + 5 µS/cm)
Measuring range resolution	0.1 µS/cm
Linearity	± 2 %
Repeatability	± (0.2 % of the measured value + 2 µS/cm)
Response time t_{90}	From 3 s (without filter) to 40 s (with slow filter)

Temperature measurement

Measurement deviation	± 1 °C (1.8 °F)
Measuring range resolution	0.1 °C (0.18 °F)
4...20 mA output uncertainty	± 1 % of current range

Electrical data

Power source (not supplied)	Limited power source according to UL/EN 62368-1 standards or limited energy circuit according to UL/EN 61010-1 paragraph 9.4
Protection against DC polarity reversal	Yes

Medium data

Fluid temperature	<p>With conductivity sensor in:</p> <ul style="list-style-type: none"> • PP: 0...+80 °C (+32...+176 °F) • PVDF: -15...+100 °C (+5...+212 °F) • PEEK: -15...+130 °C (+5...+266 °F) <p>For the variant for general applications, temperature limits may depend on the material the Type S020 Insertion fitting used is made of. Further information can be found in chapter "5.1. Pressure temperature diagram" on page 15, in the data sheet and in the instruction manual, see Type S020 ▶.</p> <p>If the temperature ranges given for the device and the fitting are different, use the most restrictive range.</p>
Fluid pressure	<p>With conductivity sensor in:</p> <ul style="list-style-type: none"> • PP: max. PN 6 (87 PSI) • PVDF: max. PN 6 (87 PSI) • PEEK: max. PN 10 (145 PSI) <p>For the variant for general applications, pressure limits may depend on the material the Type S020 Insertion fitting used is made of. Further information can be found in chapter "5.1. Pressure temperature diagram" on page 15, in the data sheet and in the instruction manual, see Type S020 ▶.</p> <p>If the pressure ranges given for the device and the fitting are different, use the most restrictive range.</p>

Process/Pipe connection & communication

Process connection	<ul style="list-style-type: none"> • Variant for general applications: G 2" for use with Type S020 Insertion fitting • Variant for CIP applications: clamp 2" according to ASME BPE (clamp 1.5" on request)
--------------------	---

Approvals and conformities

Directives

CE directive	Further information on the CE directive can be found in chapter "2.3. Standards" on page 8.
Pressure equipment directive	Complying with article 4, paragraph 1 of 2014/68/EU directive Further information on the pressure equipment directive can be found in chapter "2.4. Pressure Equipment Directive (PED)" on page 9.
North America (USA/Canada)	UL Recognized for the USA and Canada

Environment and installation

Ambient temperature	Operating and storage: -10...+60 °C (+14...+140 °F)
Relative air humidity	≤ 85 %, without condensation
Height above sea level	Max. 2000 m
Operating condition	Continuous
Equipment mobility	Fixed
Application range	Indoor and outdoor Protect the device against electromagnetic interference, ultraviolet rays and, when installed outdoors, against the effects of climatic conditions.
Installation category	Category I according to UL/EN 61010-1
Pollution degree	Degree 2 according to UL/EN 61010-1

1.3. ELEMENT standard variant



Product properties

Material

Further information on the materials can be found in chapter **“3.2. Material specifications”** on page 10.

Non wetted parts

Cover	Polycarbonate (PC), transparent (opaque on request)
Housing	Stainless steel 1.4404 (316L), PPS
Screw	Stainless steel 1.4401 (316 (A4))
Grounding terminal and screw	Stainless steel 1.4301 (304 (A2))
Display/configuration module	PC
Navigation Key	PBT
Seal	EPDM, silicone
Fixed connector holder	PPS CF30
Fixed connector	<ul style="list-style-type: none"> Variant for general applications: nickel-plated brass Variant for CIP applications: stainless steel 316L

Wetted parts

Seal	<ul style="list-style-type: none"> Variant for general applications: FKM (standard) or EPDM (option) Variant for CIP applications: EPDM (standard) or FKM (on request)
------	--

Product accessory

Display/configuration module	Grey dot matrix 128 x 64 with backlighting
------------------------------	--

Electrical data

Operating voltage	12...36 V DC, $\pm 10\%$ oscillation rate, filtered and regulated, Connection to main supply: permanent (through external SELV (Safety Extra Low Voltage) and LPS (Limited Power Source) power supply)
Power/Current consumption	<ul style="list-style-type: none"> Without the consumption of the current outputs and the transistor outputs: max. 1 W (25 mA at 12 V DC; inrush current ~ 100 mA) With the consumption of the current outputs and the transistor outputs: max. 40 W (max. 1 A for the transistor outputs)
Output	<p>The device is available with one transistor and one 4...20 mA analogue outputs (2 outputs meter) or with two transistor and two 4...20 mA analogue outputs (4 outputs meter)</p> <ul style="list-style-type: none"> Pulse (transistor): <ul style="list-style-type: none"> Polarized Configurable through wiring and through parameterizing as sourcing (PNP) or sinking (NPN) NPN-output: 1...36 V DC, max. 700 mA (or 500 mA max. per transistor if both transistor outputs are wired) PNP-output: V+ supply voltage, max. 700 mA (or 500 mA max. per transistor if both transistor outputs are wired) Galvanic insulation and protected against overvoltage, polarity reversals and short circuit Current (3-wire): <ul style="list-style-type: none"> 4...20 mA configurable through wiring and through parameterizing as sourcing or sinking, 22 mA to indicate a fault (can be parametered) Loop impedance max.: 1100 Ω at 36 V DC; 610 Ω at 24 V DC; 100 Ω at 12 V DC Response time (10...90 %): 150 ms (default value)
Voltage supply cable	<p>The female M12 connector and/or the male M12 connector are not included in the delivery and must be ordered separately, see chapter “11.5. Ordering chart accessories” on page 26.</p> <p>For these connectors, use a shielded cable with:</p> <ul style="list-style-type: none"> diameter: 3...6.5 mm cross section of wires: max. 0.75 mm²

DTS 1000220089 EN Version: T Status: RL (released | freigegeben | validé) printed: 22.04.2024

Process/Pipe connection & communication

Electrical connection	For the device with: <ul style="list-style-type: none"> • 2 outputs meter (3-wire): 1 x 5-pin M12 male connector • 4 outputs meter (3-wire): 1 x 5-pin M12 male + 1 x 5-pin M12 female connectors
-----------------------	---

Approvals and conformities

Foods and beverages/Hygiene	<ul style="list-style-type: none"> • FDA-FDA declaration of conformity (only for standard or CIP variants with PEEK or PVDF sensor holder and EPDM or FKM seal) • ECR1935/2004 declaration (only for standard or CIP variants with PEEK sensor holder and EPDM seal)
-----------------------------	--

Environment and installation

Degree of protection ^{1.)} according to IEC/EN 60529	IP65, IP67 under the following simultaneous conditions: <ul style="list-style-type: none"> • device wired • cover screwed tight • M12 connector mounted and tightened
---	--

1.) Not evaluated by UL

1.4. ELEMENT neutrino variant



Product properties

Material
 Further information on the materials can be found in chapter **“3.2. Material specifications” on page 10.**

Non wetted parts

Cover	PPS
Light guide	Polycarbonat black / PMMA / NBR88
Housing	<ul style="list-style-type: none"> • Stainless steel 1.4404 (316L), PPS (metallic variant) • PPS (all-plastic variant)
Grounding terminal	Nickel-plated brass (only metallic variant)
Seal	EPDM
Fixed connector	<ul style="list-style-type: none"> • Nickel-plated brass (metallic variant) • PA66 (all-plastic variant)

Electrical data

Operating voltage	12...36 V DC, filtered and regulated Connection to main supply: permanent, through external SELV (Safety Extra Low Voltage) and LPS (Limited Power Source) power supply
Current consumption	≤ 50 mA (with sensor)
Power consumption	≤ 1 W

Input/Output

Digital input/output	Through the communication interface <ul style="list-style-type: none"> • Bürkert system bus (bùS)/CANopen • IO-Link
----------------------	---

Recommended connection cable

The female M12 connector is not included in the delivery and must be ordered separately, see chapter **“11.5. Ordering chart accessories” on page 26.**

For this connector, use according to the variant of the device:

- a Canopen standard cable for Bürkert system bus (bùS)/CANopen communication, max. 50 m length
- a standardised industrial cable (unshielded 3- or 4-wire cable) for IO-Link communication, max. 20 m length

Process/Pipe connection & communication

Electrical connection	1 x 5-pin free positionable M12 male connector
-----------------------	--

DTS 1000220089 EN Version: T Status: RL (released | freigegeben | validé) printed: 22.04.2024

Data transfer

Digital communication: bÜS

External communication Through bÜS (Bürkert system bus, CANopen protocol)

Digital communication: IO-Link

Communication interface	IO-Link device V1.1.2
SIO mode	No
Baud rate (data transfer rate)	COM 3 (230.4 kBaud)
Type of ports	Class A
Cycle time	Min. 5 ms
Process data width	48 Input bits, 8 Output bits
IO-Link data storage	Yes
Block configuration	No
IO device description (IODD)	The device description is available in the operating instructions which can be found on our website under the "User Manuals" heading for Type 8228 ▶. Alternatively, see "Device Description Files" under the "Software" heading for Type 8228 ▶ or at https://ioddfinder.io-link.com

Environment and installation

Degree of protection	<ul style="list-style-type: none"> • IP65^{1.)}, IP67^{1.)} (according to IEC/EN 60529) • NEMA 4X and NEMA 6P (according to NEMA250) (with device installed on the fitting) • UL50E under the following simultaneous conditions: <ul style="list-style-type: none"> • device wired • cover screwed tight • M12 connector mounted and tightened
----------------------	--

1.) Not evaluated by UL

2. Approvals and conformities

2.1. General notes

- The approvals and conformities listed below must be stated when making enquiries. This is the only way to ensure that the product complies with all required specifications.
- Not all available variants of the device can be supplied with the below mentioned approvals or conformities.

2.2. Conformity

In accordance with the Declaration of Conformity, the product is compliant with the EU Directives.

2.3. Standards

The applied standards which are used to demonstrate compliance with the EU Directives are listed in the EU-Type Examination Certificate and/or the EU Declaration of Conformity.

2.4. Pressure Equipment Directive (PED)

The device conforms to article 4, paragraph 1 of the Pressure Equipment Directive (PED) 2014/68/EU under the following conditions:

Device used on a pipe

Note:

- The data in the table is independent of the chemical compatibility of the material and the fluid.
- PS = maximum admissible pressure (in bar), DN = nominal diameter of the pipe

Type of fluid	Conditions
Fluid group 1, article 4, paragraph 1.c.i	DN ≤ 25
Fluid group 2, article 4, paragraph 1.c.i	DN ≤ 32 or PS*DN ≤ 1000
Fluid group 1, article 4, paragraph 1.c.ii	DN ≤ 25 or PS*DN ≤ 2000
Fluid group 2, article 4, paragraph 1.c.ii	DN ≤ 200 or PS ≤ 10 or PS*DN ≤ 5000

Device used on a vessel

Note:

- The data in the table is independent of the chemical compatibility of the material and the fluid.
- PS = maximum admissible pressure (in bar), V = vessel volume

Type of fluid	Conditions
Fluid group 1, article 4, paragraph 1.a.i	V > 1 L and PS*V ≤ 25 bar.L or PS ≤ 200 bar
Fluid group 2, article 4, paragraph 1.a.i	V > 1 L and PS*V ≤ 50 bar.L or PS ≤ 1000 bar
Fluid group 1, article 4, paragraph 1.a.ii	V > 1 L and PS*V ≤ 200 bar.L or PS ≤ 500 bar
Fluid group 2, article 4, paragraph 1.a.ii	PS > 10 bar and PS*V ≤ 10000 bar.L or PS ≤ 1000 bar

2.5. North America (USA/Canada)

Approval	Description
	<p>Optional: UL Recognized for the USA and Canada The products are UL Recognized for the USA and Canada according to:</p> <ul style="list-style-type: none"> • UL 61010-1 • CAN/CSA-C22.2 No. 61010-1

2.6. Foods and beverages/Hygiene

Conformity	Description
	<p>FDA – Code of Federal Regulations (valid for the variable code PL02, PL03) Only the standard or CIP variants with PEEK or PVDF sensor holder and EPDM or FKM seal are compliant with the Code of Federal Regulations published by the FDA (Food and Drug Administration, USA) according to the manufacturer’s declaration.</p>
	<p>EC Regulation 1935/2004 of the European Parliament and of the Council (valid for the variable code PL01, PL02) Only wetted materials of the standard or CIP variants with PEEK sensor holder and EPDM seal are compliant with EC Regulation 1935/2004/EC according to the manufacturer’s declaration.</p>

DTS 1000220089 EN Version: T Status: RL (released | freigegeben | validé) printed: 22.04.2024

3. Materials

3.1. Bürkert resistApp

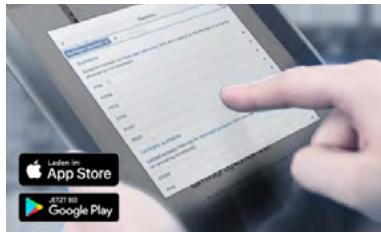

Bürkert resistApp – Chemical resistance chart

You want to ensure the reliability and durability of the materials in your individual application case? Verify your combination of media and materials on our website or in our resistApp.

[Start chemical resistance check](#)

3.2. Material specifications

ELEMENT standard variant

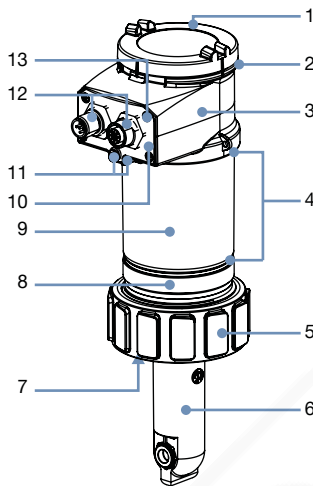

With G 2" process connection

No.	Element	Material
1	Cover	PC
2	Seal	Silicone
3	Housing (top)	PPS
4	Seals	EPDM
5	Nut	PC or PPA (with PEEK sensor armature)
6	Sensor armature	PP, PVDF or PEEK
7	Seal	FKM (standard) or EPDM (option)
8	Housing (base)	PPS
9	Housing (body)	Stainless steel 1.4404 (316L)
10	Fixed connector holder	PPS CF30
11	Grounding terminal and screw	Stainless steel 1.4301 (304 (A2))
12	M12 fixed connector (female / male)	Nickel-plated brass
13	Screws	Stainless steel 1.4401 (316 (A4))

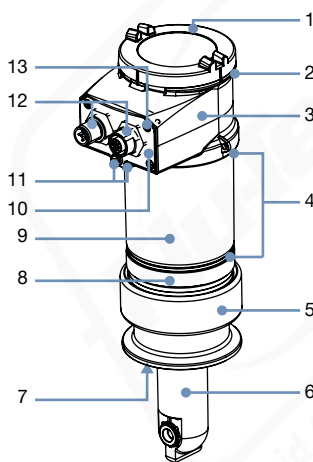

With 2" clamp process connection

No.	Element	Material
1	Cover	PC
2	Seal	Silicone
3	Housing (top)	PPS
4	Seals	EPDM
5	Process connection (clamp)	Stainless steel 1.4404 (316L)
6	Sensor armature	PEEK (standard) or PVDF (on request)
7	Seal	EPDM (standard) or FKM (on request)
8	Housing (base)	PPS
9	Housing (body)	Stainless steel 1.4404 (316L)
10	Fixed connector holder	PPS CF30
11	Grounding terminal and screw	Stainless steel 1.4301 (304 (A2))
12	M12 fixed connector (female / male)	Stainless steel 316L
13	Screws	Stainless steel 1.4401 (316 (A4))

DTS 1000220089 EN Version: T Status: RL (released | freigegeben | validé) printed: 22.04.2024

ELEMENT neutrino variant

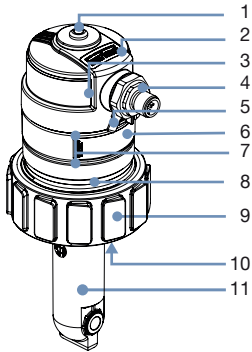

With G 2" process connection

No.	Element	Material
1	Light guide	PC, PMMA and NBR88
2	Cover	PPS
3	Seal	EPDM
4	M12 male fixed connector	<ul style="list-style-type: none"> PA66 (all-plastic variant) Nickel-plated brass (metallic variant)
5	Grounding terminal	Nickel-plated brass (only metallic variant)
6	Housing (body)	<ul style="list-style-type: none"> PPS (all-plastic variant) Stainless steel 1.4404 (316L), PPS (metallic variant)
7	Seal	EPDM
8	Housing (base)	PPS
9	Union nut	PC or PPA (with PEEK sensor armature)
10	Seal	FKM (standard) or EPDM (option)
11	Sensor armature	PP, PVDF or PEEK

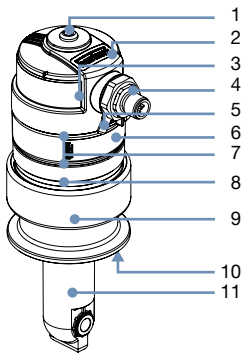

With 2" clamp process connection

No.	Element	Material
1	Light guide	PC, PMMA and NBR88
2	Cover	PPS
3	Seal	EPDM
4	M12 male fixed connector	<ul style="list-style-type: none"> PA66 (all-plastic variant) Nickel-plated brass (metallic variant)
5	Grounding terminal	Nickel-plated brass (only metallic variant)
6	Housing (body)	<ul style="list-style-type: none"> PPS (all-plastic variant) Stainless steel 1.4404 (316L), PPS (metallic variant)
7	Seal	EPDM
8	Housing (base)	PPS
9	Process connection (clamp)	Stainless steel 1.4404 (316L)
10	Seal	EPDM (standard) or FKM (on request)
11	Sensor armature	PEEK (standard) or PVDF (on request)

DTS 1000220089 EN Version: T Status: RL (released | freigegeben | valide) printed: 22.04.2024



4. Dimensions

4.1. ELEMENT standard variant

With G 2" process connection

Note:

Dimensions in mm, unless otherwise stated

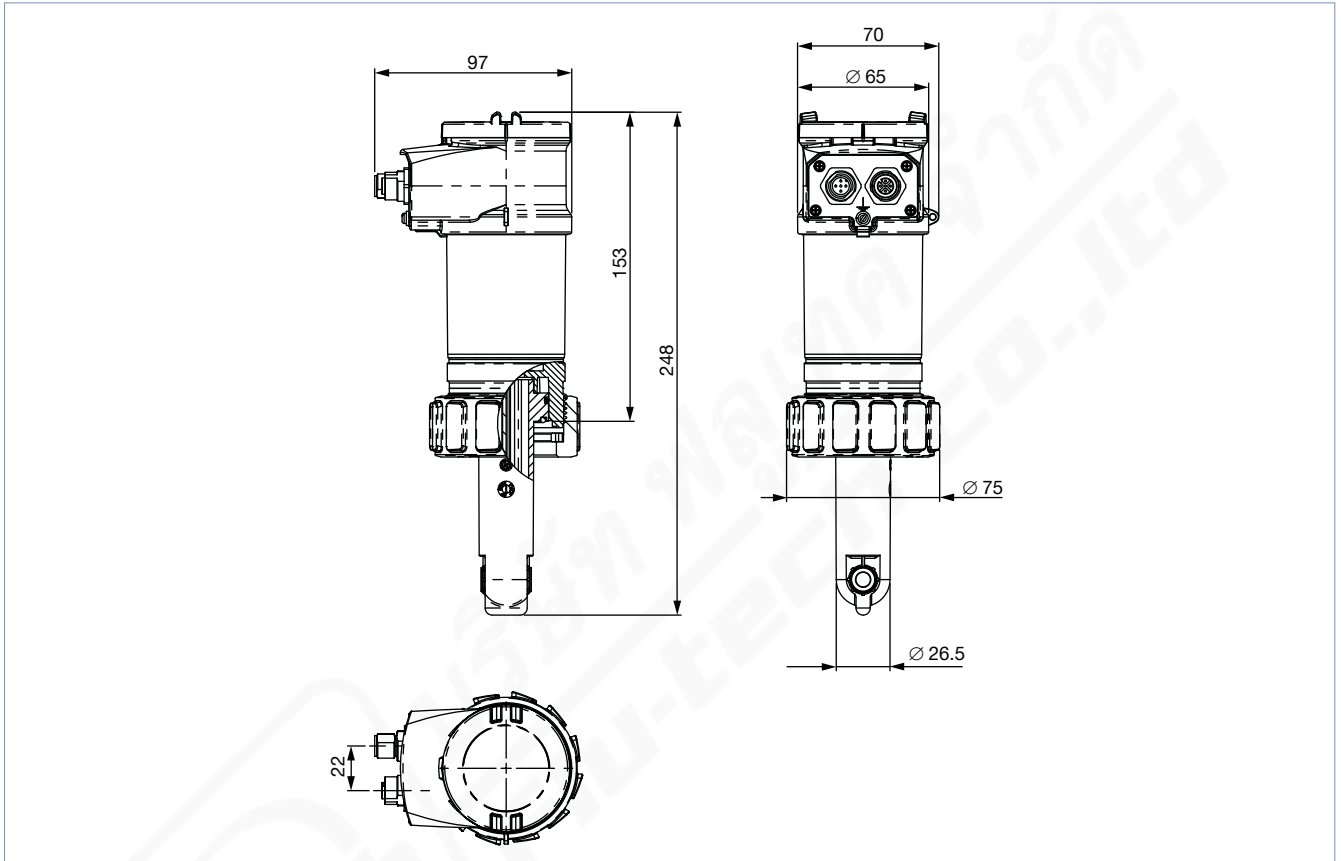

With G 2" process connection, installed in an Insertion fitting Type S020

Note:

Dimensions in mm, unless otherwise stated

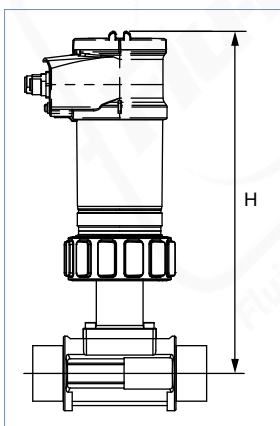

DN	H		
	T-Fitting	Plastic spigot	Metal spigot
15	235 ^{1.)}	–	–
20	235 ^{1.)}	–	–
25	235 ^{1.)}	–	–
32	235	–	–
40	239	–	–
50	245	–	240
65	245	266 ^{2.)}	246
80	–	266 ^{2.)}	251
100	–	266 ^{2.)}	261
125	–	301	272
150	–	308	283
200	–	329	304

1.) Only use plastic fittings with true union process connection in analytical variant, with nut and solvent/fusion socket according to DIN 8063 (PVC), to DIN 16962 (PP) or to ISO 10931 (PVDF).

2.) Use fusion spigot connection (article no. 418652, 418660 or 418644 in PP, PVDF or PE respectively) for orifice DN 65...DN 100.

With 2" clamp process connection

Note:

- Dimensions in mm, unless otherwise stated
- Technical data for 1.5" clamp available on request

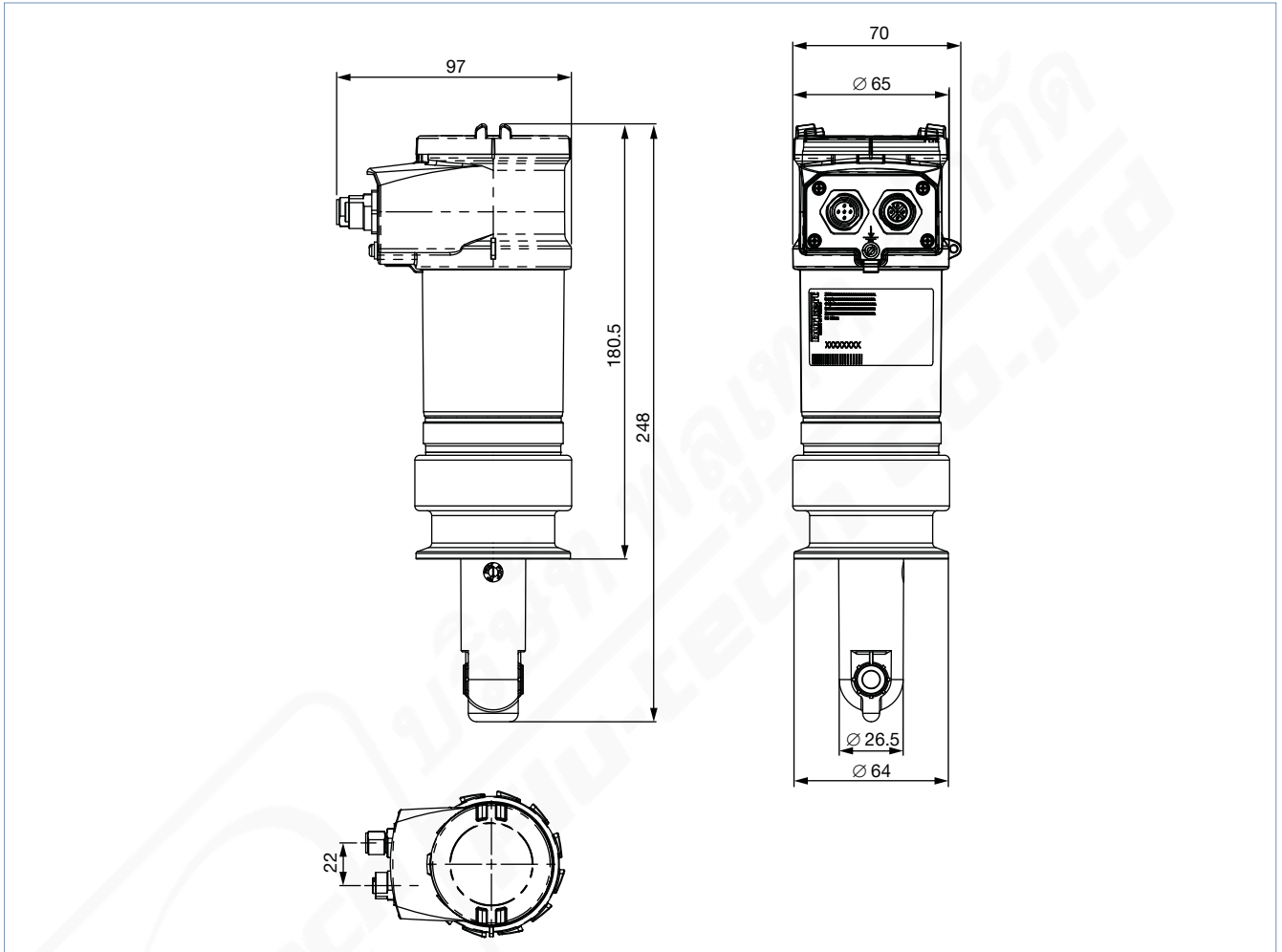

4.2. ELEMENT neutrino variant

With G 2" process connection

Note:

Dimensions in mm, unless otherwise stated

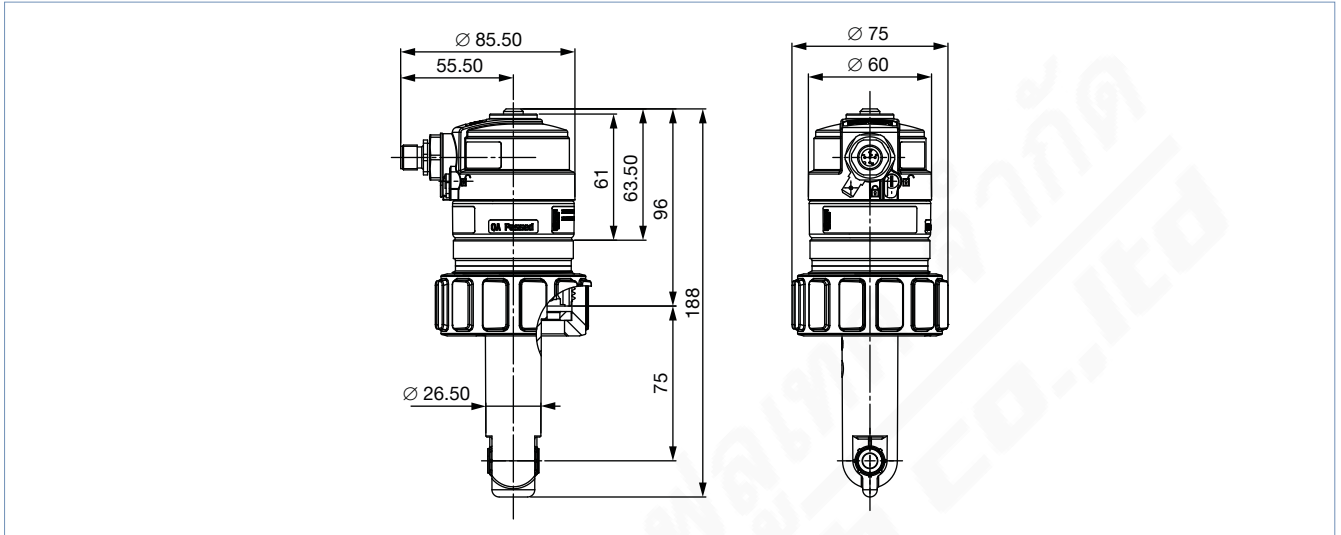

With G 2" process connection, installed in an Insertion fitting Type S020

Note:

Dimensions in mm, unless otherwise stated

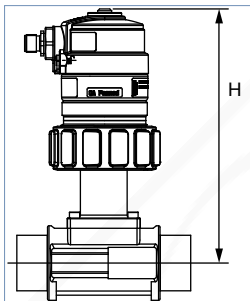

DN	H		
	T-Fitting	Plastic spigot	Metal spigot
15	178 ^{1.)}	-	-
20	178 ^{1.)}	-	-
25	178 ^{1.)}	-	-
32	178	-	-
40	182	-	-
50	188	-	183
65	188	209 ^{2.)}	189
80	-	209 ^{2.)}	194
100	-	209 ^{2.)}	204
125	-	244	215
150	-	251	226
200	-	272	247

1.) Only use plastic fittings with true union process connection in analytical variant, with nut and solvent/fusion socket according to DIN 8063 (PVC), to DIN 16962 (PP) or to ISO 10931 (PVDF).

2.) Use fusion spigot connection (article no. 418652, 418660 or 418644 in PP, PVDF or PE respectively) for orifice DN 65...DN 100.

With 2" clamp process connection

Note:

- Dimensions in mm, unless otherwise stated
- Technical data for 1.5" clamp available on request

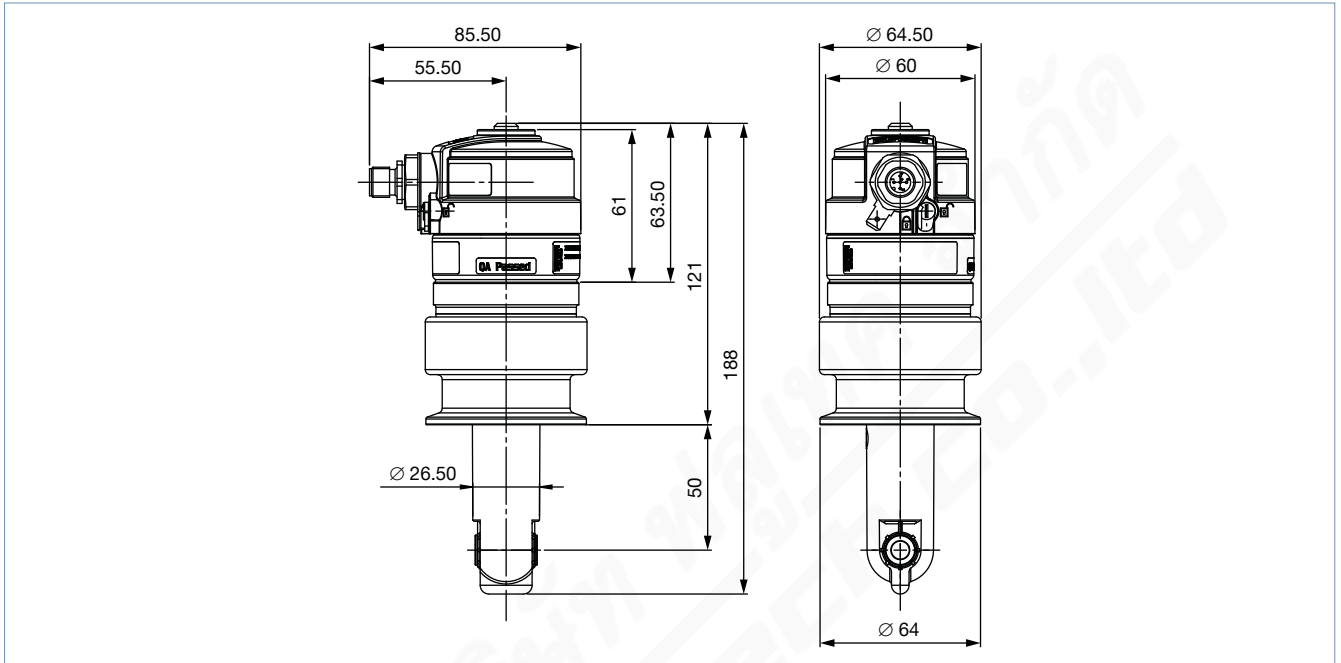

5. Performance specifications

5.1. Pressure temperature diagram

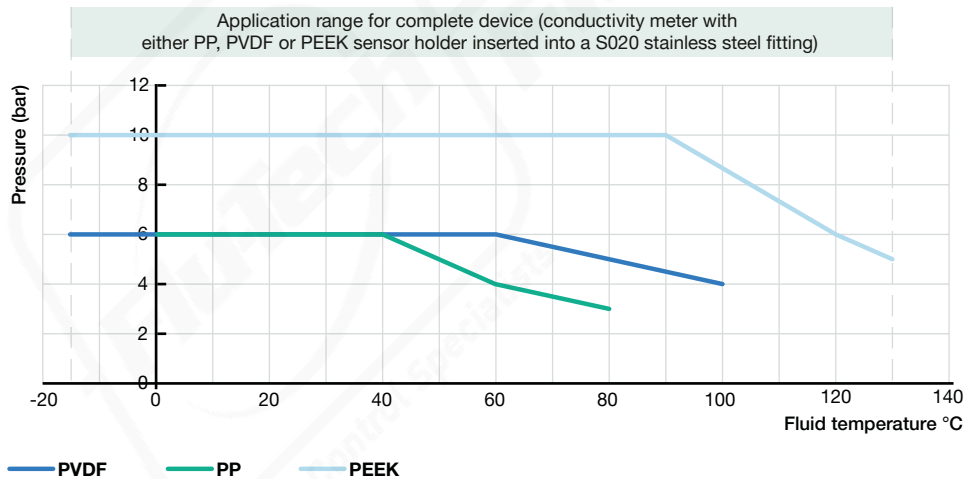

6. Product installation

6.1. Installation notes

With G 2" process connection

Note:

The conductivity meter Type 8228 can be installed into most of Bürkert Insertion fittings Type S020. Further information on the combination possibilities of the fittings can be found in chapter "10.2. Combination with available Type S020 Insertion fittings DN" on page 21.

See **data sheet Type S020** ▶ for more information.

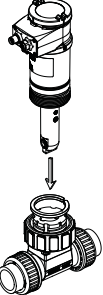
Installation example	Description
	<p>The 8228 conductivity meter (standard or neutrino variant) is installed in the pipe together with a Bürkert insertion fitting (Type S020). Select and install the required fitting onto the pipe, according to specific requirements of the sensor and fitting material, temperature and pressure. Then cautiously install the unit on the fitting and tighten with the nut.</p> <p>Further information on the assembly can be found in chapter "8.1. Product assembly" on page 19.</p>

With 2" clamp process connection

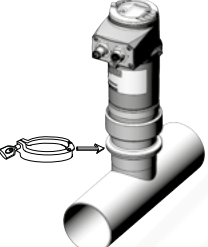
Installation example	Installation example
	<p>Mount the device (standard or neutrino variant) in a stainless steel pipe of min. DN 32 which is fitted out with a clamp 2" according to ASME BPE as process connection for the device and carefully positioning it as shown opposite. The electrical connections have to be parallel with the pipe.</p>

DTS 1000220089 EN Version: T Status: RL (released | freigegeben | validé) printed: 22.04.2024

6.2. Mounting options

Note:

- In order to get a reliable measurement, air bubbles must be avoided and the mounting location must ensure that the electrode is continuously and completely immersed in the flow stream.
- The device must be protected from heat, direct sunlight and other environmental influences.
- The sensor can be installed in any position.
- The drawings show the assembly of the measuring device in the standard ELEMENT variant with a G 2" process connection. This also applies to the other variants.

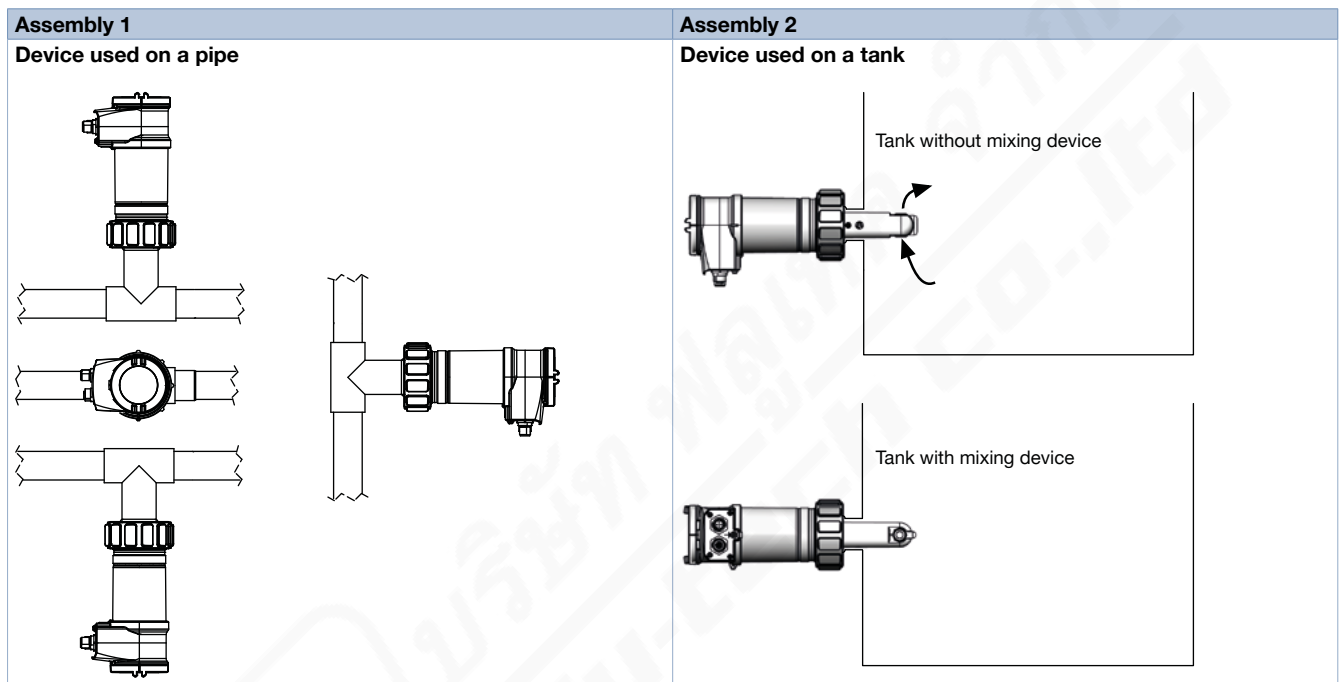

7. Product operation

7.1. Measuring principle

Conductivity is defined by the property of a solution to conduct electrical current. The charge carriers are ions (e.g. dissolved salts or acids).

The measuring cell consists of a emitting coil and a receiving coil, which are placed around the hollow measuring tube. This assembly is inserted into the lower part of the moulded probe housing and is thus separated from the fluid surrounding the probe, but which is also present in the hole crossing the probe (hollow measuring tube).

An alternating voltage (AC) is applied to the primary (emitting) coil, which generates a magnetic field. Following Lenz-Faraday's law, an electric current is then induced in the fluid, which then generates a magnetic field that is detected by the secondary (receiver) coil. The intensity of the current measured at the secondary coil is a direct function of the quantity of ions in the solution, and the conductivity is derived.

The electrical conductivity of a given medium also depends on its temperature. Several temperature compensation modes are available and can be chosen to satisfy the needs for the different applications. The integrated transmitter module converts the measured signals (conductivity and temperature) into common values, monitors limit values, displays different values in different physical units via the optional display module (if mounted) and computes the output signals.

Depending on the variant, the device Type 8228 is available with either:

- one transistor and one 4...20 mA analogue outputs (1 x M12)
- two transistor and two 4...20 mA analogue outputs (2 x M12).

The 4...20 mA standard output signal is proportional to the conductivity and/or to the temperature of the fluid. The conductivity meter is a three-wire device and requires a power supply of 12...36 V DC.

The ELEMENT neutrino device provides in a digital way different measures (conductivity, temperature, resistivity, and concentration) that can be accessed by the IO-Link or the bus terminal.

DTS 1000220089 EN Version: T Status: RL (released | freigegeben | validé) printed: 22.04.2024

7.2. Functional overview

Concentration table

Both variant of the transmitter Type 8228 transmitter are able to determine the concentration of a two-component mixture based on its conductivity and temperature. For this purpose, a concentration table for five different aqueous solutions is available. One of nine concentration ranges, which are perfectly matched to the application, can be selected.

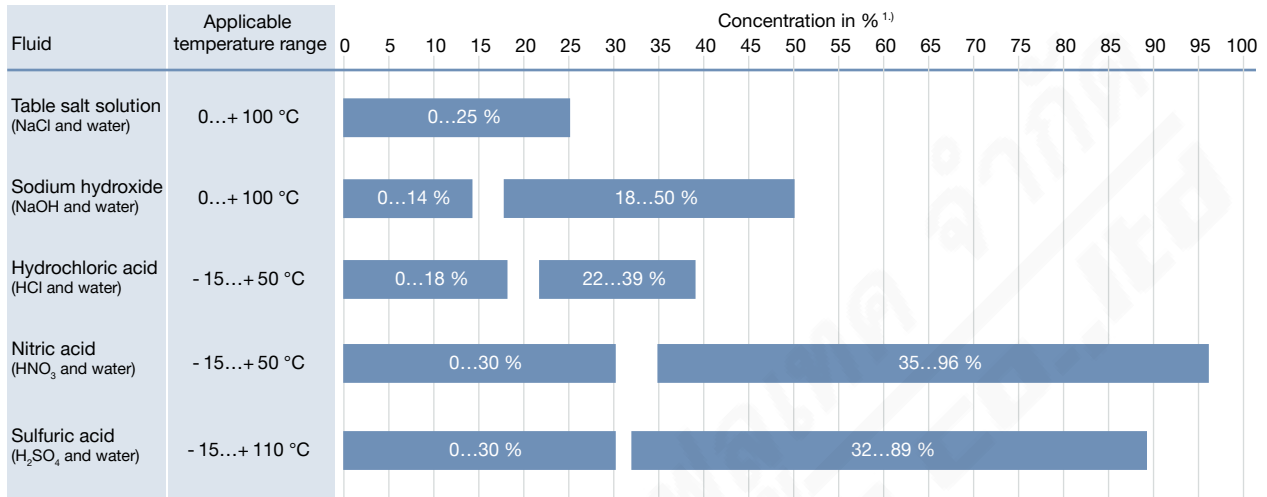

¹⁾ The "%" involved on the x-axis refers to "% mass".

DTS 1000220089 EN Version: T Status: RL (released | freigegeben | valide) printed: 22.04.2024

8. Product design and assembly

8.1. Product assembly

The conductivity meter Type 8228 (standard or neutrino variant) consists of an inductive sensor, plugged-in and pinned to an enclosure with cover, containing the electronic module. The measuring element consists of a pair of magnetic coils (called primary and secondary) moulded in a PP, PVDF or PEEK armature. A temperature probe (without direct contact to the fluid) is fitted to the sensor armature for automatic temperature compensation (standard feature).

A removable display/configuration module complements the ELEMENT standard transmitter variant. The ELEMENT standard conductivity meter can operate independently of the display but it will be required for parameterize the device (i.e. selection of sensor cell constant, language, measuring range, engineering units, calibration...) and also for visualizing continuously the measured and processed data. The ELEMENT neutrino conductivity meter is parameterize and communicates via a digital IO-Link or bûS (Bürkert system bus, CANopen protocol) interface.

With G 2" process connection

Note:

The Bürkert Type S020 Insertion fitting ensures simple installation into pipelines from DN 15...DN 200.

See **data sheet Type S020** ▶ for more information.

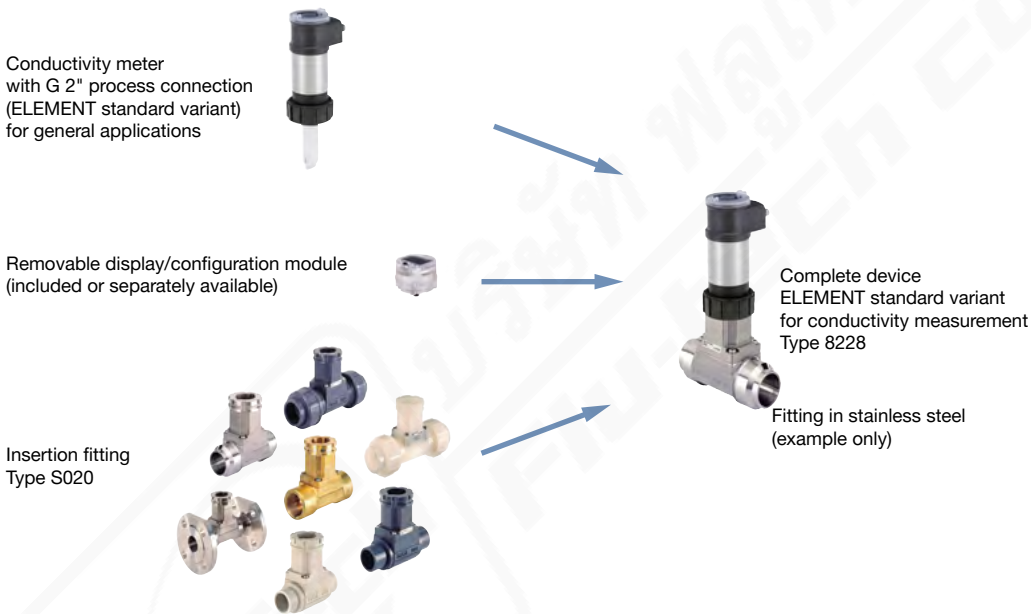

With 2" clamp process connection



DTS 1000220089 EN Version: T Status: RL (released | freigegeben | validé) printed: 22.04.2024

9. Product accessories

Note:

To configure a device with a digital communication, use the USB-büS interface Type 8923 and the Bürkert Communicator software Type 8920.

See **Software manual Type 8920** ▶ for more information.

Accessories	No.	Description
USB-büS interface set 1 	1	Quick-Start
	2	Power supply: 100...240 V AC/ 24 V DC 1 A and adaptors for power supply worldwide use
	3	büS terminating resistor on büS Y-splitter
	4	5-pin M12 male connector wired on free end cable, cable length: 0.2 m
	5	büS connection cable with 5-pin M12 male connector, micro USB B plug, cable length: 0.3 m
	6	büS adaptor with 5-pin M12 male connector, A-coded to 5-pin M12 male connector, A-coded
	7	büS stick (USB to büS/CANopen adaptor)
	8	büS service cable with 5-pin M12 female connector, mini USB plug and circular female connector for power supply, cable length: 0.7 m
	9	Magnetic key
	10	CD - Communicator (30-day license without registration, update and licensing over Bürkert home page)
USB-büS interface set 2 	5	
	7	
	8	

10. Networking and combination with other Bürkert products

10.1. Combination with transmitter/controller and fitting

Example:

<p>Type 8228</p>	All variants			Variant with G 2" process connection
	<p>Type 8619 ▶ multiCELL Transmitter/Controller</p>	<p>Type 8611 ▶ eCONTROL - Universal controller panel, wall or rail-mounting variant</p>	<p>Type 8802 ▶ (2301 & 8693) ELEMENT Continuous control valve systems</p>	<p>Type S020 ▶ Insertion fitting for flow or analysis measurements</p>

DTS 1000220089 EN Version: T Status: RL (released | freigegeben | valide) printed: 22.04.2024

10.2. Combination with available Type S020 Insertion fittings DN

Note:

Only for device with G 2" process connection

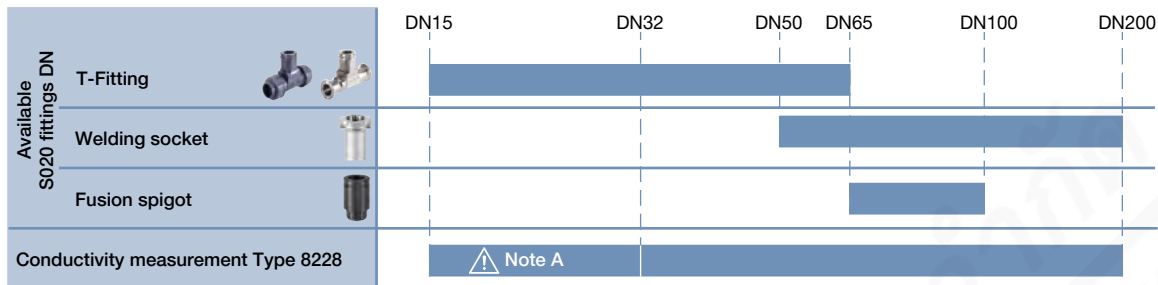

Note A: Only use plastic fitting in analytical variant with true union according to DIN 8063 (PVC), DIN 16962 (PP) or ISO 10931 (PVDF).

See **data sheet Type S020** ▶ for more information.

11. Ordering information

11.1. Bürkert eShop



Bürkert eShop – Easy ordering and quick delivery

You want to find your desired Bürkert product or spare part quickly and order directly? Our online shop is available for you 24/7. Sign up and enjoy all the benefits.

[Order online now](#)

11.2. Recommendation regarding product selection

With G 2" process connection

Note:

When only ordering devices without a display/configuration module, make sure that you have a display/configuration module at least for parameterising the device. Otherwise you must also order one (see chapter “11.5. Ordering chart accessories” on page 26) or order a pre-configured device (see chapter “11.4. Ordering chart” on page 23).

A complete conductivity measurement equipment consists of a conductivity meter Type 8228 (ELEMENT standard variant or ELEMENT neutrino variant), a removable display/configuration module (only for ELEMENT standard variant) and a Bürkert Insertion fitting Type S020.

See **data sheet Type S020** ▶ for more information.

Two or three different components must be ordered in order to select a complete device. The following information is required:

- **Article no.** of the desired conductivity meter Type 8228 in the ELEMENT standard variant with or without display/configuration module or in the ELEMENT neutrino variant (see chapter “11.4. Ordering chart” on page 23)
- **Article no.** of the removable display/configuration module, if necessary (see chapter “11.5. Ordering chart accessories” on page 26).
- **Article no.** of the selected Insertion fitting Type S020 (DN 15...DN 200). See **data sheet Type S020** ▶.

DTS 1000220089 EN Version: T Status: RL (released | freigegeben | valide) printed: 22.04.2024

With 2" clamp process connection

Note:

When only ordering devices without a display/configuration module, make sure that you have a display/configuration module at least for parameterising the device. Otherwise you must also order one (see chapter "11.5. Ordering chart accessories" on page 26).

A complete conductivity measurement equipment consists of a conductivity meter Type 8228 (ELEMENT standard variant or ELEMENT neutrino variant), a removable display/configuration module (only for ELEMENT standard variant).

One or two different components must be ordered in order to select a complete device. The following information is required:

- **Article no.** of the desired conductivity sensor Type 8228 in the ELEMENT standard variant with or without display/configuration module or in the ELEMENT neutrino variant (see chapter "11.4. Ordering chart" on page 23)
- **Article no.** of the removable display/configuration module, if necessary (see chapter "11.5. Ordering chart accessories" on page 26).

11.3. Bürkert product filter



Bürkert product filter – Get quickly to the right product

You want to select products comfortably based on your technical requirements? Use the Bürkert product filter and find suitable articles for your application quickly and easily.

[Try out our product filter](#)

11.4. Ordering chart

ELEMENT standard variant



Conductivity meter to be configured

Note:

- All settings as well as the digital output have to be configured with the display/configuration module (must be ordered separately).
- The following article nos. have a transparent cover as standard.

Operating voltage	Output	Material		UL approval	Electrical connection	Article no.	
		Sensor armature	Sensor seal			Without display	With display
With G 2" process connection, for general applications							
12...36 V DC	1 x transistor NPN/PNP + 1 x 4...20 mA	PP	FKM ^{1.)}	–	5-pin M12 male connector	565601	566601
				UL Recognized		565611	566611
		PVDF	–	565603		566603	
			UL Recognized	565613		566613	
		PEEK ^{2.)}	–	565605		566605	
			UL Recognized	565615		566615	
	2 x transistors NPN/PNP + 2 x 4...20 mA	PP	–	5-pin M12 male and 5-pin M12 female connectors	565602	566602	
					UL Recognized	565612	566612
		PVDF	–		565604	566604	
			UL Recognized		565614	566614	
		PEEK ^{2.)}	–		565606	566606	
			UL Recognized		565616	566616	
With 2" clamp process connection according to ASME BPE, for CIP applications							
12...36 V DC	1 x transistor NPN/PNP + 1 x 4...20 mA	PEEK	EPDM ^{3.)}	–	5-pin M12 male connector	567200	567478
				UL Recognized		567480	567482
	2 x transistors NPN/PNP + 2 x 4...20 mA	–	–	5-pin M12 male and 5-pin M12 female connectors	567199	567479	
					UL Recognized	567481	567483

1.) The following is supplied with every device: FKM seal as standard (already mounted), 1 set with a green FKM seal and a black EPDM seal for the sensor.
 2.) Union nut in PPA
 3.) FKM is available on request

Further variants on request	
 <p>Material</p> <ul style="list-style-type: none"> • For variant with G 2" process connection: All-plastic housing and M12 plastic connectors • For variant with clamp process connection PVDF sensor armature FKM seal 	 <p>Process connection Clamp 1½"</p>

DTS 1000220089 EN Version: T Status: RL (released | freigegeben | valide) printed: 22.04.2024

Conductivity meter pre-configured for direct start-up

Note:

- The installation expense is reduced as the device can be directly started up.
- Default setting: without filtering, temperature compensation linear 2 %/°C, 1 analogue output in sink mode and 1 digital output (transistor: not assigned)
- The following article nos. have an opaque cover as standard.

Operating voltage	Conductivity range (4...20 mA output corresponds to ...)	Material		UL approval	Electrical connection	Article no.
		Sensor armature	Sensor seal			Without display
With G 2" process connection, for general applications						
12...36 V DC	0...1 mS/cm	PP	FKM ^{1.)}	-	5-pin M12 male connector	566560
	0...10 mS/cm					566561
	0...100 mS/cm					566562
	0...1 S/cm					566563
	0...1 mS/cm	PVDF	566564			
	0...10 mS/cm		566565			
	0...100 mS/cm		566566			
	0...1 S/cm		566567			
	0...1 mS/cm	PEEK ^{2.)}	566568			
	0...10 mS/cm		566569			
	0...100 mS/cm		566570			
	0...1 S/cm		566571			

1.) The following is supplied with every device: FKM seal as standard (already mounted), 1 set with a green FKM seal and a black EPDM seal for the sensor.
 2.) Union nut in PPA

Further variants on request	
<p>Material For variant with G 2" process connection: All-plastic housing and M12 plastic connectors</p>	<p>Process connection Clamp 1½", 2"</p>
<p>Additional Configurations: 2- or 4- outputs, filter, temperature compensation, threshold, etc.</p>	

DTS 1000220089 EN Version: T Status: RL (released | freigegeben | validé) printed: 22.04.2024

ELEMENT neutrino variant

Note:

The communication protocol is selected automatically by the device depending on the master controlling it.

Operating voltage	Output	Material		UL approval	Electrical connection	Article no.
		Sensor armature	Sensor seal			
Metallic variant with G 2" process connection, for general applications						
12...36 V DC	Digital IO-Link and büS/ CANopen communication	PP	FKM ^{1.)}	-	5-pin M12 male connector	574278
				UL Recognized		574279
		PVDF		-		574290
				UL Recognized		574291
		PEEK ^{2.)}		-		574280
				UL Recognized		574281
Metallic variant 2" with clamp process connection according to ASME BPE, for CIP applications						
12...36 V DC	Digital IO-Link and büS/ CANopen communication	PEEK	EPDM ^{3.)}	-	5-pin M12 male connector	574282
				UL Recognized		574283
All-plastic variant with G 2" process connection, for general applications						
12...36 V DC	Digital IO-Link communica- tion	PP	FKM ^{1.)}	-	5-pin M12 male connector	574284
				UL Recognized		574285
		PVDF		-		574288
				UL Recognized		574289
		PEEK ^{2.)}		-		574286
				UL Recognized		574287

1.) FKM seal in standard; 1 set including a green FKM and a black EPDM seals for the sensor is supplied with each measuring device.





























2.) Union nut in PPA

Further variants on request

	<p>Material</p> <ul style="list-style-type: none"> For variant with G 2" process connection: All-plastic housing and M12 plastic connectors For variant with clamp process connection PVDF sensor armature FKM seal 		<p>Process connection</p> <p>Clamp 1½"</p>
--	--	--	---

DTS 1000220089 EN Version: T Status: RL (released | freigegeben | validé) printed: 22.04.2024

11.5. Ordering chart accessories

Description	Article no.
Seals	
For ELEMENT neutrino variant	
EPDM seal for cover/housing sealing	561752 
Spare part	
For ELEMENT standard variant	
Opaque cover with seal (1 screw cover with EPDM seal + 1 quarter turn closing cover with silicone seal)	560948 
Transparent cover with seal (1 screw cover with EPDM seal + 1 quarter turn closing cover with silicone seal)	561843 
Mounting accessory	
For ELEMENT standard and neutrino variants with G 2" process connection, for general applications	
Set with a green FKM seal and a black EPDM seal	552111 
Fastening ring (open) for Type S020 Insertion fitting	619205 
PC union nut for Type S020 Insertion fitting	619204 
Electrical connection	
For all variants	
M12 female connector with plastic threaded clamping ring, 5-pin, straight, to be wired	917116 
M12 female connector with moulded cable (shielded), 5-pin, straight, cable length: 2 m	438680 
For ELEMENT standard variant	
M12 male connector with plastic threaded clamping ring, 5-pin, straight, to be wired	560946 
M12 male connector with moulded cable (shielded), 5-pin, straight, cable length: 2 m	559177 
Configuration accessory	
For ELEMENT standard variant	
Removable display/configuration module (with instruction sheet)	559168 
For all variants	
Buffer solution, 300 ml, conductivity standard: 706 µS/cm, ±2 % accuracy	440018 
Buffer solution, 300 ml, conductivity standard: 1413 µS/cm, ±1 % accuracy	440019 
Buffer solution, 300 ml, conductivity standard: 100 mS/cm, ±1 % accuracy	440020 
System Connect	
Type ME43 Gateway/Interface	
Industrial Ethernet gateway (PROFINET IO, EtherNet/IP, Modbus TCP, EtherCAT®)	307390 
PROFIBUS gateway (PROFIBUS DPV1)	307393 
Type ME61 Display	
FieldConnect ME61 3.5" display (8.9 cm)	368544 
EDIP Accessories	
büS Stick Set	
 USB-büS interface set 1 (Type 8923) Further information can be found in chapter "9. Product accessories" on page 20.	772426 
USB-büS interface set 2 (Type 8923) Further information can be found in chapter "9. Product accessories" on page 20.	772551 
Connectors	
büS M12 female connector, 5-pin, straight, A-coded	772416 
büS M12 male connector, 5-pin, straight, A-coded	772417 
büS M12 female connector, 5-pin, angled, A-coded	772418 
büS M12 male connector, 5-pin, angled, A-coded	772419 
büS Y-distributor (M12 female connector, 5-pin to M12 male and female connectors, 5-pin)	772420 
büS Y-distributor with power interrupt (M12 female connector, 5-pin to M12 male and female connectors, 5-pin)	772421 
büS adaptor (M12 male connector, 5-pin, A-coded to M12 male connector, 5-pin, A-coded)	772867 
büS terminating resistor 120 ohms, M12 male connector, 5-pin	772424 
büS terminating resistor 120 ohms, M12 female connector, 5-pin	772425 

Description		Article no.
Connectors with cable		
Adaptor cable with M12 female connector, 8-pin to M12 male connector, 5-pin	0.5 m	773286
M12 female connector, 5-pin, angled, moulded on büS cable, with open leads	0.7 m	772626
M12 female connector, 5-pin, straight, moulded on büS cable, with open leads	1 m	772409
	3 m	772410
	5 m	772411
	10 m	772412
M12 male connector, 5-pin straight and micro USB connector, moulded on büS cable	0.3 m	773254
M12 female connector, 8-pin, straight, moulded on büS cable, with open leads	2 m	919061
Extensions		
 M12 female and male connectors, 5-pin, straight, moulded on büS cable, shielded	0.1 m	772492
	0.2 m	772402
	0.5 m	772403
	1 m	772404
	3 m	772405
	5 m	772406
	10 m	772407
	20 m	772408
Power supply unit for standard rail Type 1573		
100...240 V AC / 24 V DC, 1 A (Class 2 according to NEC)		772361
100...240 V AC / 24 V DC, 2 A (Class 2 according to NEC)		772362
100...240 V AC / 24 V DC, 3.8 A (Class 2 according to NEC)		772898
100...240 V AC / 24 V DC, 10 A		772698

DTS 1000220089 EN Version: T Status: RL (released | freigegeben | valide) printed: 22.04.2024

