



Direct-acting 2-way standard solenoid control valve

- Excellent range
- Very good response
- Compact valve design
- Orifice sizes 2...9.5 mm
- Optional: Explosion-protected coil

Product variants described in the data sheet may differ from the product presentation and description.

Can be combined with



Type 8605 ▶
PWM control electronics
for electromagnetic
proportional valves



Type 2518 ▶
Cable plug,
form A according to
DIN EN 175301 - 803



Type 8611 ▶
eCONTROL - Universal
controller

Type description

The direct-acting solenoid control valve Type 2875 is used as the regulating unit in control loops. Due to an elastomeric seat seal the valve closes tight (integrated shut-off function), up to the DN specific nominal pressure. The plunger of the valve is assembled frictionless, which leads to an extraordinary adjustment characteristic. This valve is particularly suitable for demanding control tasks (high control range, dry gases, etc.).



FLU-TECH CO. LTD.

Email: sales@flutech.co.th **Website:** <https://flutech.co.th>

Tel: 02-384-6060, 086-369-5871-3 **Fax:** 02-384-5701 **LINE OA:** @flutech.co.th

Address (HQ): 845/3-4, Moo 3, Theparak Rd., T. Theparak, A. Mueang Samut Prakan, Samut Prakan, 10270, Thailand

Table of contents

| | |
|---|-----------|
| 1. General technical data | 3 |
| 2. Circuit functions | 3 |
| 3. Approvals and conformities | 4 |
| 3.1. General notes..... | 4 |
| 3.2. Conformity | 4 |
| 3.3. Standards..... | 4 |
| 3.4. Explosion protection | 4 |
| 3.5. North America (USA/Canada) | 4 |
| 3.6. Foods and beverages/Hygiene | 4 |
| 4. Materials | 5 |
| 4.1. Bürkert resistApp | 5 |
| 5. Dimensions | 6 |
| 5.1. Standard version..... | 6 |
| Threaded body..... | 6 |
| Sub-base body | 7 |
| 5.2. ATEX version | 8 |
| Threaded body..... | 8 |
| Sub-base body | 9 |
| 6. Performance specifications | 9 |
| 6.1. Flow characteristic..... | 9 |
| Determination of the K_v value | 9 |
| 6.2. Exemplary characteristic curve of a proportional valve | 10 |
| 7. Product operation | 10 |
| 7.1. Control unit | 10 |
| 8. Ordering information | 11 |
| 8.1. Bürkert eShop..... | 11 |
| 8.2. Recommendation regarding product selection..... | 11 |
| 8.3. Bürkert product filter..... | 11 |
| 8.4. Bürkert Product Enquiry Form | 11 |
| 8.5. Ordering chart..... | 12 |
| Standard version..... | 12 |
| Version with ATEX/IECEx approval | 12 |
| Version for higher differential pressures..... | 13 |
| Version for higher differential pressures with ATEX/IECEx approval..... | 13 |
| 8.6. Ordering chart accessories..... | 14 |
| Cable plug Type 2518, form A according to DIN EN 175301 - 803 | 14 |
| Control electronics Type 8605 for proportional valves | 15 |

1. General technical data

| Product properties | |
|--|--|
| Dimensions | Further information can be found in chapter "5. Dimensions" on page 6. |
| Material | |
| Body | Brass, stainless steel |
| Seal | FKM, EPDM |
| Performance data | |
| Typical values of positioning behaviour ^{1.)} | |
| Hysteresis | < 5 % |
| Repeat accuracy | < 0.5 % of end value ^{2.)} |
| Response sensitivity | < 0.25 % of end value ^{2.)} |
| Setting range | 1:200 |
| Actuating time (10...90 %) | < 25 ms |
| Pressure range ^{3.)} | 0...363 psi |
| Nominal operating mode | 100 % continuous operation |
| Electrical data | |
| Operating voltage | 24 V DC (12 V on request) |
| Power consumption | 16 W |
| Maximum coil current ^{4.)} | 750 mA (at 16 W and 24 V coil) |
| PWM frequency ^{5.)} | 900 Hz |
| Medium data | |
| Operating medium | Neutral gases, liquids on request |
| Medium temperature | + 14 °F...+ 194 °F (with FKM) - 22 °F...+ 194 °F (with EPDM) |
| Viscosity | Max. 21 mm ² /s (21 cSt) |
| Process/Port connection & communication | |
| Port connection size | Sub-base, G 3/8, G 1/2, NPT 3/8, NPT 1/2 |
| Electrical connection | Cable plug Type 2518, form A according to DIN EN 175301 - 803 Further information can be found in chapter "Cable plug Type 2518, form A according to DIN EN 175301 - 803" on page 14. |
| Approvals and conformities | |
| Degree of protection | IP65 |
| Environment and installation | |
| Installation position | As required, preferably with actuator upright |
| Ambient temperature | Max. + 131 °F |

- 1.) Characteristic data of control behaviour depends on process conditions
- 2.) By flow measurement
- 3.) Pressure data: overpressure to atmospheric pressure, depending on nominal diameter, tightness seal or nominal pressure
- 4.) Maximum value: value depends on operating pressure
- 5.) PWM: pulse width modulation

2. Circuit functions

| Symbol | Description |
|--------|---|
| | Circuit function A (CF A) 2/2-way solenoid proportional control valve Direct-acting Normally closed |

DTS 1000593845 EN Version: B Status: RL (released | freigegeben | valide) printed: 25.10.2023

3. Approvals and conformities

3.1. General notes

- The approvals and conformities listed below must be stated when making enquiries. This is the only way to ensure that the product complies with all required specifications.
- Not all available versions can be supplied with the below mentioned approvals or conformities.



3.2. Conformity

In accordance with the Declaration of conformity, the product is compliant with the EU Directives.

3.3. Standards

The applied standards which are used to demonstrate compliance with the EU Directives are listed in the EU-Type Examination Certificate and/or the EU Declaration of Conformity.

3.4. Explosion protection

| Approval | Description |
|---|--|
|   | Optional: Explosion protection ATEX: II 2 G Ex mb IIC T4 Gb II 2 D Ex mb IIIC T130 °C Db IECEX: Ex mb IIC T4 Gb Ex mb IIIC T130 °C Db |

3.5. North America (USA/Canada)

| Approval | Description |
|---|--|
|  | Optional: UL Recognized for the USA The products are UL Recognized for the USA according to: <ul style="list-style-type: none"> • UL 429 (Electrically operated valves) |

3.6. Foods and beverages/Hygiene

| Conformity | Description |
|---|--|
| USP | United States Pharmacopeial Convention (USP) (valid for the variable code PL04) All wetted materials are biocompatible according to the manufacturer's declaration. |
| FDA | FDA – Code of Federal Regulations (valid for the variable code PL02, PL03) All wetted materials are compliant with the Code of Federal Regulations published by the FDA (Food and Drug Administration, USA) according to the manufacturer's declaration. |
|  | EC Regulation 1935/2004 of the European Parliament and of the Council (valid for the variable code PL01, PL02) All wetted materials are compliant with EC Regulation 1935/2004/EC according to the manufacturer's declaration. |

DTS 1000593845 EN Version: B Status: RL (released | freigegeben | valide) printed: 25.10.2023

4. Materials

4.1. Bürkert resistApp

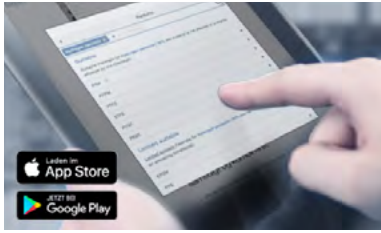

Bürkert resistApp – Chemical resistance chart

You want to ensure the reliability and durability of the materials in your individual application case? Verify your combination of media and materials on our website or in our resistApp.

[Start chemical resistance check](#)



5. Dimensions

5.1. Standard version

Threaded version

Note:

Dimensions in mm [inch]

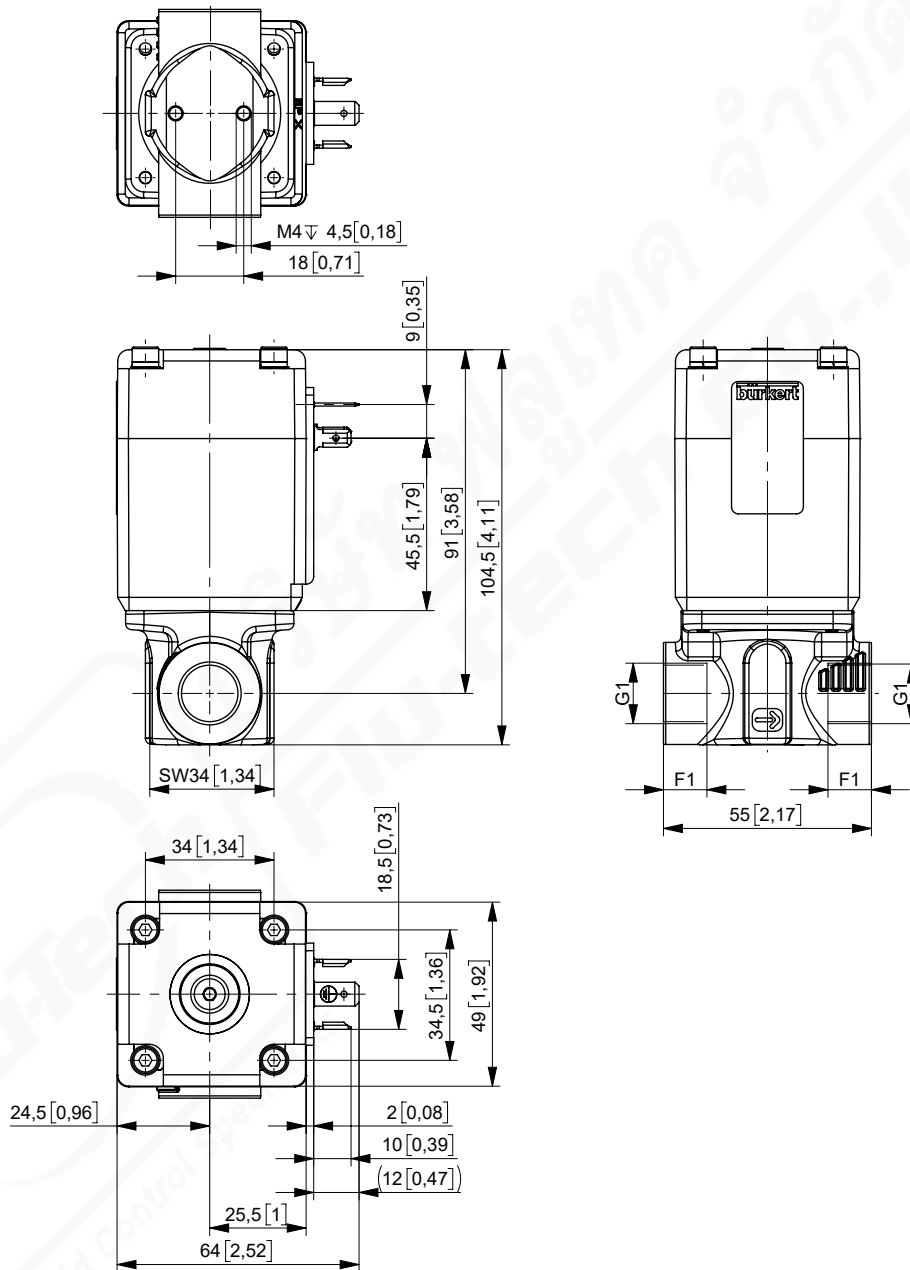

| Port connection | G1 [inch] | F1 [mm] | F1 [inch] |
|-----------------|-------------------|------------|--------------|
| Thread | G $\frac{3}{8}$ | 12 | 0.47 |
| | G $\frac{1}{2}$ | 14 | 0.55 |
| | NPT $\frac{3}{8}$ | 10.3 | 0.41 |
| | NPT $\frac{1}{2}$ | 13.7 | 0.54 |

Sub-base version

Note:

Dimensions in mm [inch]

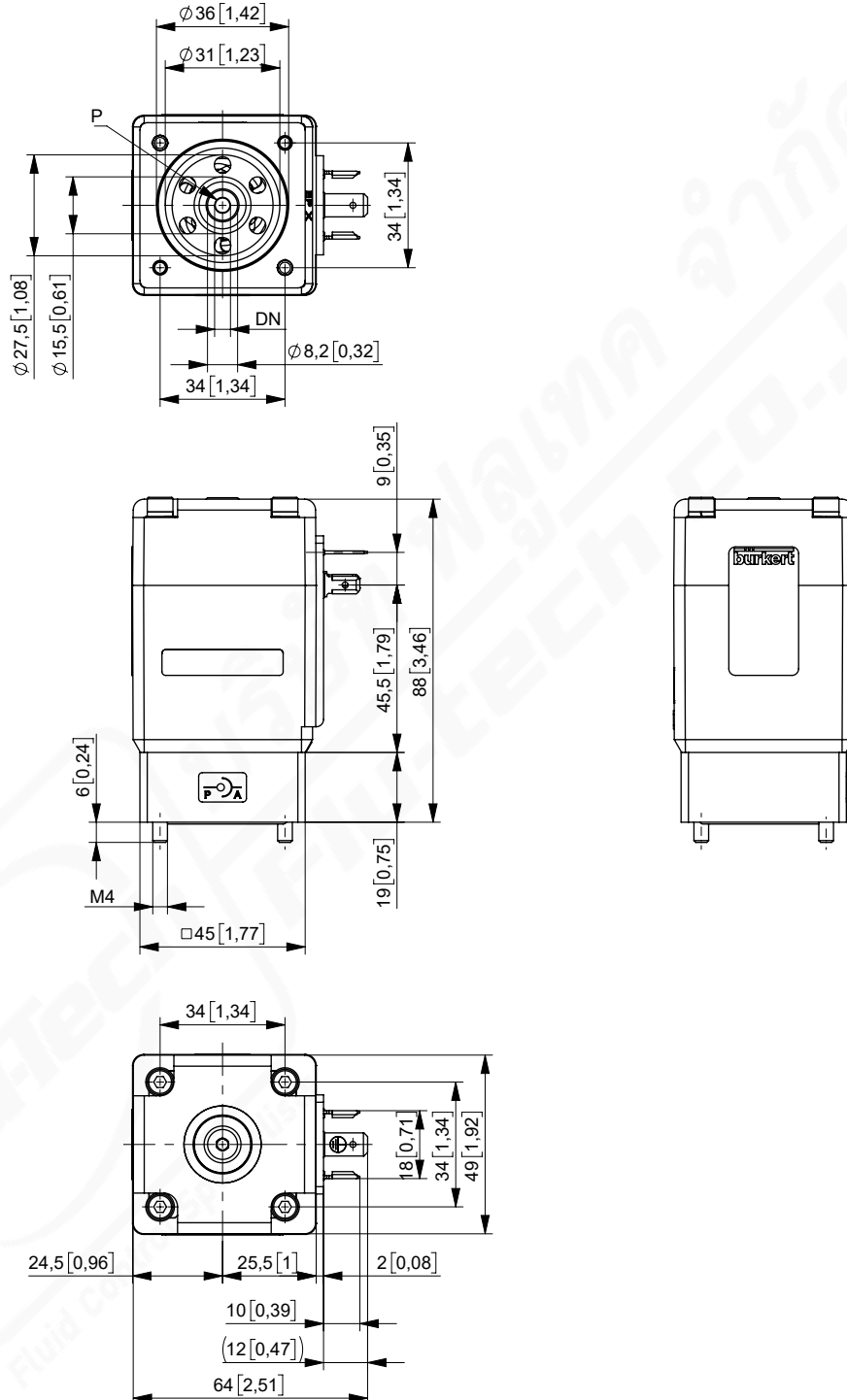

5.2. ATEX version

Threaded version

Note:

Dimensions in mm [inch]

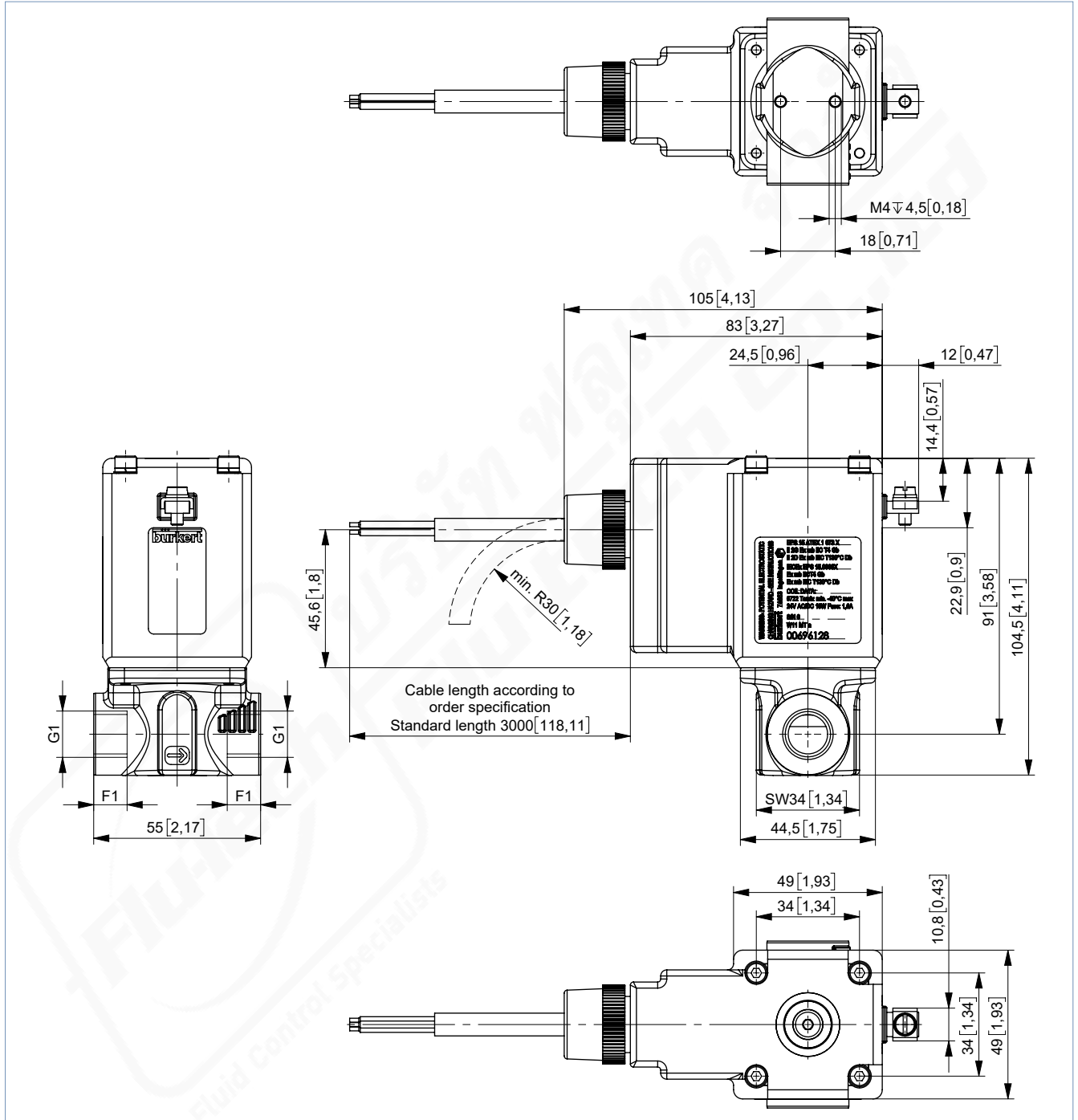

| Port connection | G1 [inch] | F1 [mm] | F1 [inch] |
|-----------------|--------------|------------|--------------|
| Thread | G 3/8 | 12 | 0.47 |
| | G 1/2 | 14 | 0.55 |
| | NPT 3/8 | 10.3 | 0.41 |
| | NPT 1/2 | 13.7 | 0.54 |

Sub-base version

Note:

Dimensions in mm [inch]

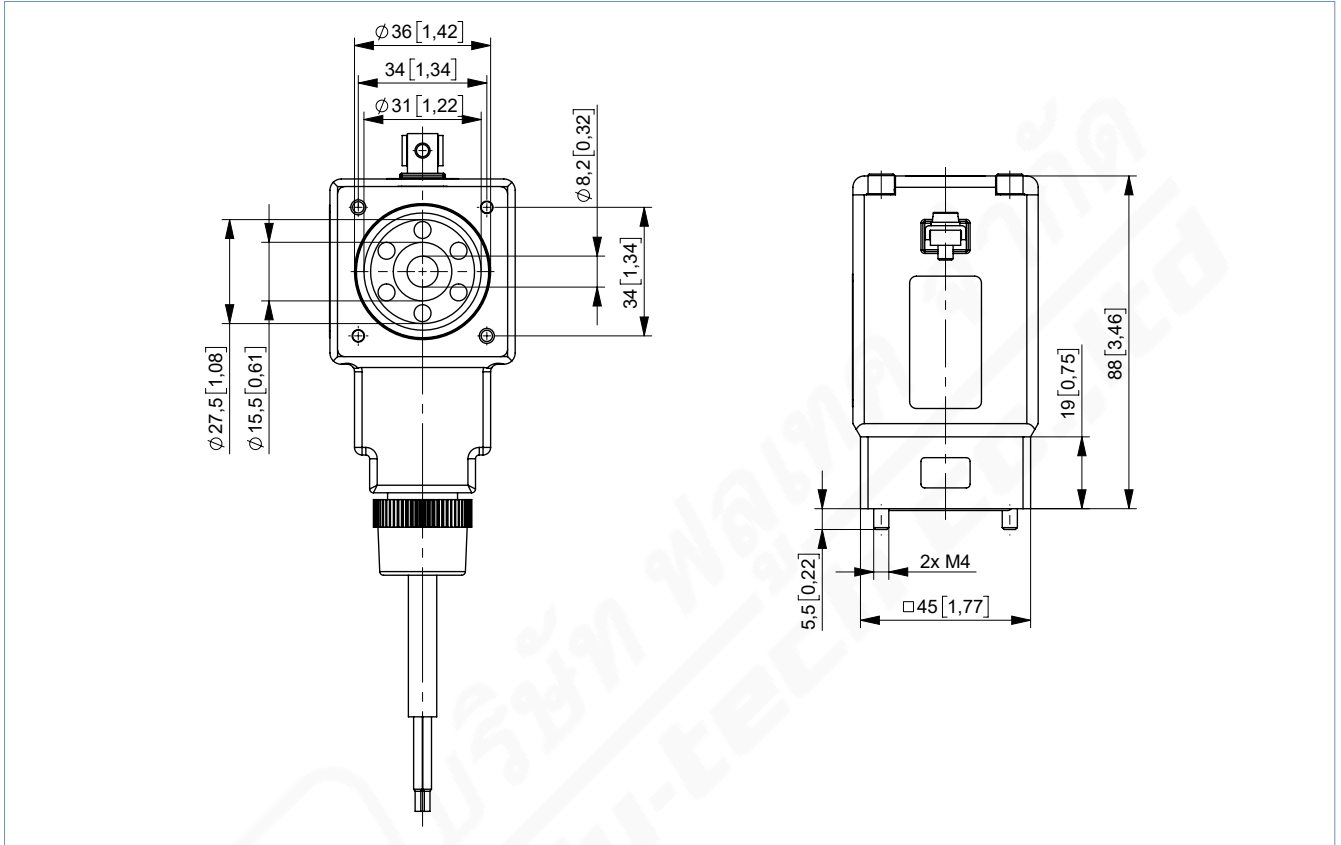

6. Performance specifications

6.1. Flow characteristic

Determination of the K_v value

| Pressure drop | K_v value for liquids | K_v value for gases |
|---|---|--|
| | [m ³ /h] | [m ³ /h] |
| Sub-critical $p_2 > \frac{p_1}{2}$ | $= Q \sqrt{\frac{\rho}{1000 \Delta p}}$ | $= \frac{Q_N}{514} \sqrt{\frac{T_1 \rho_N}{p_2 \Delta p}}$ |
| Supercritical $p_2 < \frac{p_1}{2}$ | $= Q \sqrt{\frac{\rho}{1000 \Delta p}}$ | $= \frac{Q_N}{257 p_1} \sqrt{T_1 \rho_N}$ |

| | | |
|------------|---|-----------------------------------|
| K_v | Flow coefficient | [m ³ /h] ¹⁾ |
| Q_N | Standard flow rate | [m ³ /h] ²⁾ |
| p_1 | Inlet pressure | [bar] ³⁾ |
| p_2 | Outlet pressure | [bar] ³⁾ |
| Δp | Differential pressure p_1, \dots, p_2 | [bar] |
| ρ | Density | [kg/m ³] |
| ρ_N | Standard density | [kg/m ³] |
| T_1 | Medium temperature | [(273+t)K] |

- 1.) Measured for water, $\Delta p = 1$ bar, over the valve
- 2.) At reference conditions 1.013 bar and 0 °C (273 K)
- 3.) Absolute pressure

6.2. Exemplary characteristic curve of a proportional valve

Note:

In continuous flow applications, the choice of an appropriate valve size is much more important than with on/off valves. The optimum size should be selected such that the resulting flow in the system is not unnecessarily reduced by the valve. However, a sufficient part of the pressure drop should be taken across the valve even when it is fully opened.

Reference value: $\Delta p_{\text{valve}} > 25\%$ of the total pressure drop

Otherwise, an ideal, linear valve characteristic is deformed into a curved system characteristic.

If the differential pressure (difference between inlet and outlet pressure) exceeds half the value of the nominal pressure discontinuities may occur.

For that reason take advantage of Bürkert competent engineering services during the planning phase.

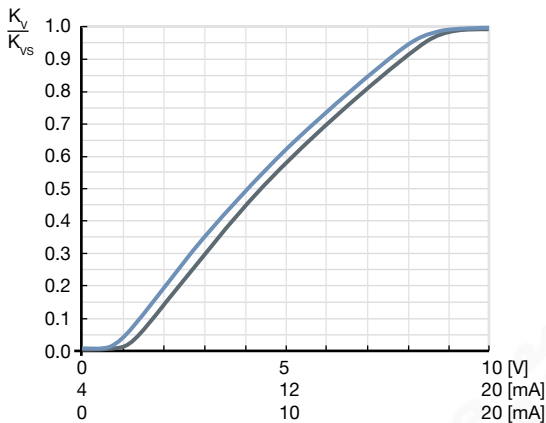

7. Product operation

7.1. Control unit

Valve control takes place through a PWM signal (pulse-width modulation). The duty cycle of the PWM signal determines the coil current and hence the position of the plunger.

The Bürkert control electronics Type 8605 (see data sheet **Type 8605** ▶) converts an analogue signal to a reference value corresponding to the valve type PWM signal and provides additional functions such as temperature compensation (coil heating), ramp function and the adjustment of min. and max. duty cycle/coil current for the control range.

Please note the sizing comments for such a control valve in chapter **“6.2. Exemplary characteristic curve of a proportional valve”** on page 10.

DTS 1000593845 EN Version: B Status: RL (released | freigegeben | validé) printed: 25.10.2023

8. Ordering information

8.1. Bürkert eShop



Bürkert eShop – Easy ordering and quick delivery

You want to find your desired Bürkert product or spare part quickly and order directly? Our online shop is available for you 24/7. Sign up and enjoy all the benefits.

[Order online now](#)

8.2. Recommendation regarding product selection

Note:

- Use the product enquiry form (see “8.4. Bürkert Product Enquiry Form” on page 11) for information about the device layout and send it to us after completion.
- Please note the chapter “6.2. Exemplary characteristic curve of a proportional valve” on page 10 on product selection.

8.3. Bürkert product filter



Bürkert product filter – Get quickly to the right product

You want to select products comfortably based on your technical requirements? Use the Bürkert product filter and find suitable articles for your application quickly and easily.

[Try out our product filter](#)

8.4. Bürkert Product Enquiry Form

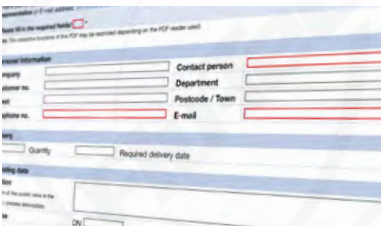

Bürkert Product Enquiry Form – Your enquiry quickly and compactly

Would you like to make a specific product enquiry based on your technical requirements? Use our Product Enquiry Form for this purpose. There you will find all the relevant information for your Bürkert contact. This will enable us to provide you with the best possible advice.

[Fill out the form now](#)

DTS 1000593845 EN Version: B Status: RL (released | freigegeben | validé) printed: 25.10.2023

8.5. Ordering chart

Standard version

Note:

- All valves with FKM seal and UL Recognized approval
- Other connection variants (Sub-base, G) on request
- Please note that the cable plug must be ordered separately, see “Cable plug Type 2518, form A according to DIN EN 175301 - 803” on page 14 or separate data sheet for Type 2518 ▶.

| Circuit function | Port connection ^{1.)} | Orifice | C _{vs} value water ^{2.)} | Nominal pressure ^{3.)} (MAWP ^{4.)}) | Maximum differential pressure (MAOP ^{5.)}) | Article no. Brass body | Article no. Stainless steel body |
|--|--------------------------------|---------|--|--|--|------------------------|----------------------------------|
| | | [mm] | [gal/min] | [psi] | [psi] | | |
| CF A 2/2-way solenoid proportional control valve Direct-acting Normally closed | NPT 3/8 | 2.0 | 0.14 | 363 | 181 | 274977 ☒ | 274989 ☒ |
| | NPT 3/8 | 3.0 | 0.29 | 145 | 73 | 274979 ☒ | 274991 ☒ |
| | NPT 3/8 | 4.0 | 0.52 | 116 | 58 | 274981 ☒ | 274993 ☒ |
| | NPT 1/2 | | 0.52 | 116 | 58 | 274983 ☒ | 274995 ☒ |
| | NPT 1/2 | 6.0 | 0.93 | 58 | 29 | 274985 ☒ | 274997 ☒ |
| | NPT 1/2 | 8.0 | 1.27 | 29 | 15 | 274987 ☒ | 274999 ☒ |
| | NPT 1/2 | 9.5 | 1.62 | 10 | 5 | 20071284 ☒ | 20071285 ☒ |

- 1.) Port connection: others on request
- 2.) Measurement at +68 °F, 14.5 psi pressure differential over a fully opened valve.
- 3.) Pressure data: overpressure to atmospheric pressure. If the differential pressure between the inlet and outlet pressure of the valve is greater than half of the nominal pressure, discontinuities in the valve characteristic curve are possible.
- 4.) Maximum allowable working pressure
- 5.) Maximum allowable operating pressure

Version with ATEX/IECEx approval

Note:

- All valves with FKM seal and ATEX/IECEx version with 3 m connection cable.
- Other connection variants (Sub-base, G) or stainless steel body on request
- Refer to chapter “3. Approvals and conformities” on page 4 for more information about the approvals.

| Circuit function | Port connection ^{1.)} | Orifice | C _{vs} value water ^{2.)} | Nominal pressure ^{3.)} (MAWP ^{4.)}) | Maximum differential pressure (MAOP ^{5.)}) | Article no. Brass body |
|--|--------------------------------|---------|--|--|--|------------------------|
| | | [mm] | [gal/min] | [psi] | [psi] | |
| CF A 2/2-way solenoid proportional control valve Direct-acting Normally closed | NPT 3/8 | 2.0 | 0.12 | 290 | 145 | 20062687 ☒ |
| | NPT 3/8 | 3.0 | 0.25 | 131 | 65 | 20062688 ☒ |
| | NPT 3/8 | 4.0 | 0.45 | 102 | 51 | 20062690 ☒ |
| | NPT 1/2 | | 0.45 | 102 | 51 | 20062691 ☒ |
| | NPT 1/2 | 6.0 | 0.80 | 51 | 25 | 20062694 ☒ |
| | NPT 1/2 | 8.0 | 1.10 | 22 | 11 | 20062695 ☒ |

- 1.) Port connection: others on request
- 2.) Measurement at +68 °F, 14.5 psi pressure differential over a fully opened valve.
- 3.) Pressure data: overpressure to atmospheric pressure. If the differential pressure between the inlet and outlet pressure of the valve is greater than half of the nominal pressure, discontinuities in the valve characteristic curve are possible.
- 4.) Maximum allowable working pressure
- 5.) Maximum allowable operating pressure

DTS 1000593845 EN Version: B Status: RL (released | freigegeben | valide) printed: 25.10.2023

Version for higher differential pressures

Note:

- All valves with FKM seal and UL Recognized approval
- Other connection variants (Sub-base, G) on request
- PWM frequency: 500 Hz
- Span: 1:100
- For $\Delta p > 145$ psi it is possible to get inconsistencies in the characteristic curve because of flow conditions in the application.
- Please note that the cable plug must be ordered separately, see **“Cable plug Type 2518, form A according to DIN EN 175301 - 803”** on **page 14** or separate data sheet for **Type 2518** ▶.
- Refer to chapter **“3. Approvals and conformities”** on **page 4** for more information about the approvals.

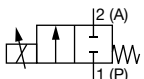
| Circuit function | Port connection ^{1.)} | Orifice | C _{vs} value water ^{2.)} | Nominal pressure ^{3.)} (MAWP ^{4.)}) | Article no. Brass body | Article no. Stainless steel body |
|---|--------------------------------|---------|--|---|---------------------------|-------------------------------------|
| | | [mm] | [gal/min] | [psi] | | |
| CF A 2/2-way solenoid proportional control valve Direct-acting Normally closed  | NPT 3/8 | 2.0 | 0.14 | 363 | 20062702 🛒 | 20062703 🛒 |
| | NPT 3/8 | 3.0 | 0.29 | 145 | 20062704 🛒 | 20062705 🛒 |
| | NPT 3/8 | 4.0 | 0.52 | 116 | 20062706 🛒 | 20062707 🛒 |
| | NPT 1/2 | | 0.52 | 116 | 20062708 🛒 | 20062710 🛒 |
| | NPT 1/2 | 6.0 | 0.93 | 58 | 20062711 🛒 | 20062713 🛒 |
| | NPT 1/2 | 8.0 | 1.27 | 29 | 20062714 🛒 | 20062715 🛒 |
| | NPT 1/2 | 9.5 | 1.62 | 10 | 20062716 🛒 | 20062717 🛒 |

- 1.) Port connection: others on request
- 2.) Measurement at +68 °F, 14.5 psi pressure differential over a fully opened valve.
- 3.) Pressure data: overpressure to atmospheric pressure. If the differential pressure between the inlet and outlet pressure of the valve is greater than half of the nominal pressure, discontinuities in the valve characteristic curve are possible.
- 4.) Maximum allowable working pressure

Version for higher differential pressures with ATEX/IECEX approval



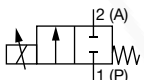

Note:

- All valves with FKM seal and ATEX/IECEX version with 3 m connection cable.
- Other connection variants (Sub-base, G) or stainless steel body on request
- PWM frequency: 500 Hz
- Span: 1:100
- For $\Delta p > 145$ psi it is possible to get inconsistencies in the characteristic curve because of flow conditions in the application.
- Refer to chapter **“3. Approvals and conformities”** on **page 4** for more information about the approvals.

| Circuit function | Port connection ^{1.)} | Orifice | C _{vs} value water ^{2.)} | Nominal pressure ^{3.)} (MAWP ^{4.)}) | Article no. Brass body |
|---|--------------------------------|---------|--|---|---------------------------|
| | | [mm] | [gal/min] | [psi] | |
| CF A 2/2-way solenoid proportional control valve Direct-acting Normally closed  | NPT 3/8 | 2.0 | 0.12 | 290 | 20062696 🛒 |
| | NPT 3/8 | 3.0 | 0.25 | 131 | 20062697 🛒 |
| | NPT 3/8 | 4.0 | 0.45 | 102 | 20062698 🛒 |
| | NPT 1/2 | | 0.45 | 102 | 20062699 🛒 |
| | NPT 1/2 | 6.0 | 0.80 | 51 | 20062700 🛒 |
| | NPT 1/2 | 8.0 | 1.10 | 22 | 20062701 🛒 |

- 1.) Port connection: others on request
- 2.) Measurement at +68 °F, 14.5 psi pressure differential over a fully opened valve.
- 3.) Pressure data: overpressure to atmospheric pressure. If the differential pressure between the inlet and outlet pressure of the valve is greater than half of the nominal pressure, discontinuities in the valve characteristic curve are possible.
- 4.) Maximum allowable working pressure

DTS 1000593845 EN Version: B Status: RL (released | freigegeben | validé) printed: 25.10.2023



| Further versions on request | | | |
|---|---|---|--|
|  | Material EPDM |  | Analytical Oxygen version, parts oil-, fat- and silicon free |
|  | Approval UR (UL recognized) ATEX/IECEX |  | Process connection Sub-base version |

8.6. Ordering chart accessories

Cable plug Type 2518, form A according to DIN EN 175301 - 803

Note:

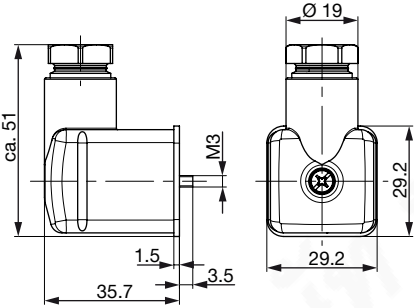
For further versions see data sheet [Type 2518](#) ▶.













| Cable plug | Dimensions | Version | Voltage | Article no. |
|---|--|---------------------------|-----------------|--|
|  |  | Without circuitry (AC/DC) | 0...250 V AC/DC | 314802  |

DTS 1000593845 EN Version: B Status: RL (released | freigegeben | valide) printed: 25.10.2023

Control electronics Type 8605 for proportional valves

Note:

Refer to data sheet **Type 8605** ▶ for more information about the control electronics.

| Control electronics | Version | Max. coil current range [mA] | Voltage | | Article no. |
|--|--|------------------------------|---------|---------|---|
| | | | 24 V DC | 12 V DC | |
|  | Cable plug with PG cable gland | 200...1000 | o. r. | – | 316530  |
| | Cable plug with M12 connection | 200...1000 | o. r. | – | 316528  |
| | Cable plug with PG cable gland | 500...2000 | o. r. | o. r. | 316529  |
| | Cable plug with M12 connection | 500...2000 | o. r. | o. r. | 316526  |
|  | Cable plug with PG cable gland without operating element | 200...1000 | o. r. | – | 316521  |
| | Cable plug with M12 connection without operating element | 200...1000 | o. r. | – | 316522  |
| | Cable plug with PG cable gland without operating element | 500...2000 | o. r. | o. r. | 316523  |
| | Cable plug with M12 connection without operating element | 500...2000 | o. r. | o. r. | 316525  |
|  | Standard rail | 200...1000 | o. r. | – | 316532  |
| | Standard rail | 500...2000 | o. r. | o. r. | 316533  |

o. r. = on request
 – = not available

DTS 1000593845 EN Version: B Status: RL (released | freigegeben | validé) printed: 25.10.2023

