





Magnetic inductive flow sensor, low flow rates

- For connection to a Type SE58 transmitter (with or without display, in compact or remote variant) for flow measurement
- Clean in place (CIP) capable
- Flow rate measurements 0.2...approx. 200 l/min for DN 03...DN 20

Product variants described in the data sheet may differ from the product presentation and description.

Can be combined with

- | | |
|-------------------------------------------------------------------------------------|-----------------------------------------------------------------------------------------------|
|  | Type SE58 ▶
L variant of the transmitter for electromagnetic-inductive flow sensors |
|  | Type SE58 ▶
M variant of the transmitter for electromagnetic-inductive flow sensors |
|  | Type SE58 ▶
S variant of the transmitter for electromagnetic-inductive flow sensors |

Type description

The magnetically inductive flow sensor Type S051 (compact or remote variant) is suitable for low-flow applications and liquids with minimum conductivity.

The combination with the dedicated Type SE58 S transmitter (minimum required conductivity: 20 µS/cm) or with the Type SE58 M or Type SE58 L transmitters (minimum conductivity required: 5 µS/cm) results in a flowmeter with different performance, functions, materials and approvals, with the corresponding suitability for the respective applications depending on the respective requirements.

With the Type SE58 S you get a compact device, with the Type SE58 M and Type SE58 L compact devices or remote versions are created for which the transmitter and sensor are connected by 2 cables up to a maximum length. Standard process connections available for the Type S051 are thread connections in G or NPT.

DTS 1000471655 EN Version: B Status: RL (released | freigegeben | validé) printed: 02.02.2024

FLU-TECH CO. LTD.

Email: sales@flutech.co.th **Website:** <https://flutech.co.th>

Tel: 02-384-6060, 086-369-5871-3 **Fax:** 02-384-5701 **LINE OA:** @flutech.co.th

Address (HQ): 845/3-4, Moo 3, Theparak Rd., T. Theparak, A. Mueang Samut Prakan, Samut Prakan, 10270, Thailand



Table of contents

1. General technical data	3
2. Approvals and conformities	5
2.1. Conformity	5
2.2. Standards.....	5
3. Materials	5
3.1. Bürkert resistApp	5
4. Dimensions	5
4.1. Compact variant.....	5
4.2. Remote variant with junction box	6
5. Product installation	6
5.1. Installation notes	6
Flow measurement.....	6
5.2. Selection of the nominal diameter	7
6. Product operation	7
6.1. Measuring principle.....	7
7. Ordering information	8
7.1. Bürkert eShop	8
7.2. Recommendation regarding product selection.....	8
7.3. Bürkert product filter.....	8
7.4. Ordering chart	8
7.5. Ordering chart accessories.....	9

DTS 1000471655 EN Version: B Status: RL (released | freigegeben | valide) printed: 02.02.2024

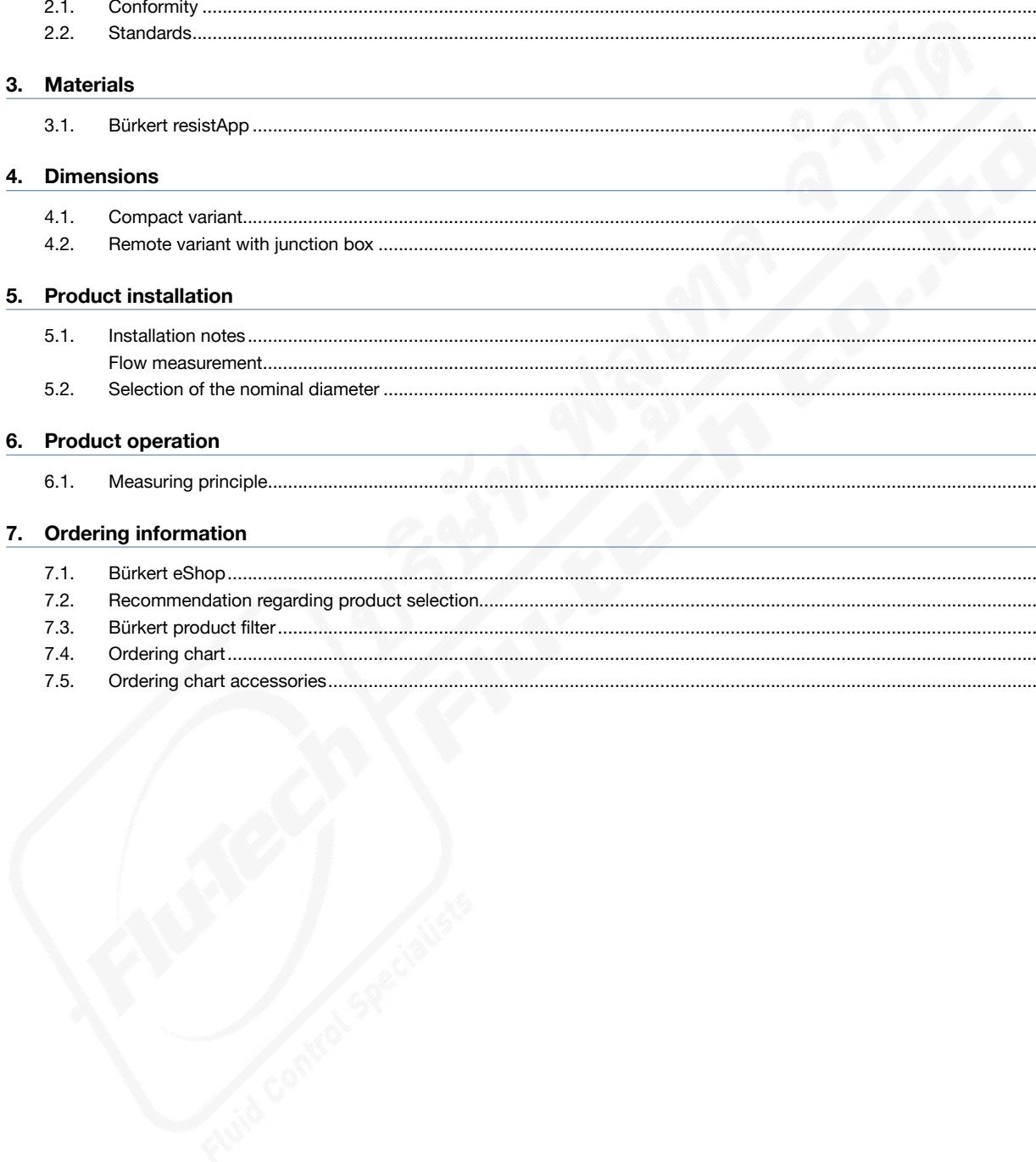

1. General technical data

Note:

Empty pipe functionality is not available for this sensor type.

The electromagnetic flow sensor Type S051 in a compact or remote variant is intended for use with transmitter Type SE58, which is available in three variants L, M or S.



Further information can be found in the data sheet of the transmitter, see [data sheet Type SE58](#) ▶.

Product properties	
Material	
Non wetted parts	
Sensor housing	Stainless steel 304 (1.4301)
Junction box	Only for remote sensor: stainless steel 304 (1.4301) raw (on request: stainless steel 304 (1.4301) polished or painted aluminium)
Wetted parts	
Process connection	<ul style="list-style-type: none"> Stainless steel 316L (1.4404) Stainless steel 304 (1.4301) with full lining variant (process connection included)
Lining	PTFE
Electrode	<ul style="list-style-type: none"> Stainless steel 316L Alloy C, Titanium, Tantalum, Platinum-rhodium on request
Seal	FKM (EPDM or FFKM on request)
Pipe diameter	DN 03...DN 20
Dimensions	Further information can be found in chapter “4. Dimensions” on page 5.
Measuring principle	Electromagnetic induction Further information can be found in chapter “6.1. Measuring principle” on page 7.
Measuring range	0...10 l/h to 0...12500 l/h Further information can be found in chapter “7.4. Ordering chart” on page 8.
Performance data	
At reference conditions and according to internal test procedures:	
<ul style="list-style-type: none"> At room temperature Constant flow rate during the test, liquid speed > 1 m/s Pressure: >30 Kpa Flow condition: observed inlet and outlet conditions Zero point stability: ±0.005 % 	
Measurement deviation	If used with transmitter Type SE58: <ul style="list-style-type: none"> in compact or remote L variant: ≤ ±0.2 % of the measured value for flow velocity >0.5 m/s in compact or remote M variant: ≤ ±0.8 % of the measured value for flow velocity >0.5 m/s in compact S variant: ≤ ±0.5 % of the measured value for flow velocity >0.5 m/s See data sheet Type SE58 ▶
Repeatability	If used with transmitter Type SE58: <ul style="list-style-type: none"> in compact or remote L variant: ≤ ±0.1 % of the measured value for flow velocity >0.5 m/s in compact or remote M variant: ≤ ±0.4 % of the measured value for flow velocity >0.5 m/s in compact S variant: ≤ ±0.25 % of the measured value for flow velocity >0.5 m/s See data sheet Type SE58 ▶
Vacuum resistance	200 mbar (2.9 PSI) absolute at 100 °C (212 °F)

DTS 1000471655 EN Version: B Status: RL (released | freigegeben | valide) printed: 02.02.2024

Medium data

Fluid temperature	If used with transmitter Type SE58: <ul style="list-style-type: none"> • In compact variant: -20...+100 °C (-4...+212 °F) • In remote variant: -20...+130 °C (-4...+266 °F)
-------------------	-----------------------------------------------------------------------------------------------------------------------------------------------------------------------------------------------------

Fluid pressure	PN 16 (PN 40 on request)
----------------	--------------------------

Minimum conductivity	5 µS/cm (or 20 µS/cm with demineralised water)
----------------------	------------------------------------------------

Process/Pipe connection & communication

Pipe connection	<ul style="list-style-type: none"> • External thread G ISO 228-1 • NPT • DIN 11851, SMS 1145, clamp, ISO 2852 or BS 4825, flange DIN 2501, ANSI on request
-----------------	---------------------------------------------------------------------------------------------------------------------------------------------------------------------------------------------

Electrical connection	2 cable glands PG9 (for remote variant of the sensor)
-----------------------	-------------------------------------------------------

Approvals and conformities

Directives

CE directive	Further information on the CE directive can be found in chapter "2.2. Standards" on page 5.
Pressure equipment directive	The device is not subject to the requirements of the Pressure Equipment Directive 2014/68/EU, as the nominal flowmeter diameters are smaller than DN 25.

Environment and installation

Ambient temperature	According to the used version of transmitter Type SE58 and its material Further information can be found in the data sheet of the transmitter, see data sheet Type SE58 ▶.
---------------------	--------------------------------------------------------------------------------------------------------------------------------------------------------------------------------------

Relative air humidity	≤90 %, without condensation
-----------------------	-----------------------------

Height above sea level	Max. 2000 m
------------------------	-------------

Operating condition	Continuous
---------------------	------------

Equipment mobility	Fixed
--------------------	-------

Application range	Indoor and outdoor Protect the device against electromagnetic interference, ultraviolet rays and against the effects of climatic conditions.
-------------------	-------------------------------------------------------------------------------------------------------------------------------------------------

Degree of protection according to IEC/EN 60529	If use with transmitter Type SE58: <ul style="list-style-type: none"> • in compact L and M variant: IP67 (IP68 optional) • in compact S variant: IP67 (IP68 optional) • in remote L and M variant: IP68
------------------------------------------------	------------------------------------------------------------------------------------------------------------------------------------------------------------------------------------------------------------------------------------------

Installation category	Category II according to UL/EN 61010-1
-----------------------	----------------------------------------

Pollution degree	Degree 2 according to UL/EN 61010-1
------------------	-------------------------------------

2. Approvals and conformities

2.1. Conformity

In accordance with the Declaration of Conformity, the product is compliant with the EU Directives.

2.2. Standards

The applied standards which are used to demonstrate compliance with the EU Directives are listed in the EU-Type Examination Certificate and/or the EU Declaration of Conformity.

3. Materials

3.1. Bürkert resistApp

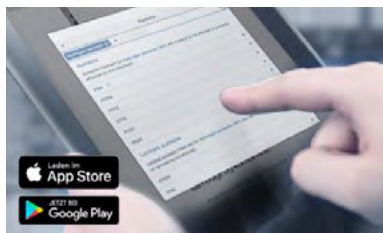

Bürkert resistApp – Chemical resistance chart

You want to ensure the reliability and durability of the materials in your individual application case? Verify your combination of media and materials on our website or in our resistApp.

[Start chemical resistance check](#)

4. Dimensions

4.1. Compact variant

Note:

- Further information on the dimensions of the Type SE58 transmitter can be found in **data sheet Type SE58** ▶.
- Dimensions in mm, unless otherwise stated

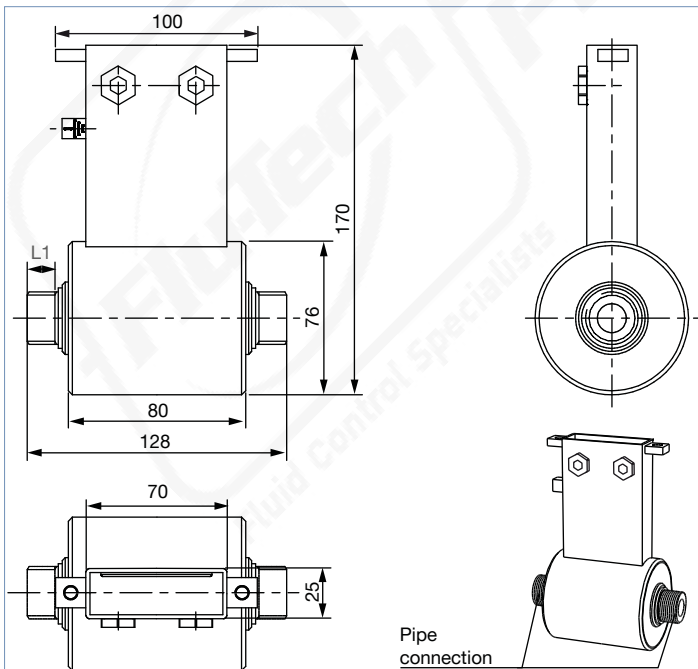

DN	Thread [Inch]	L1
03	G or NPT ¼"	16.4
06	G or NPT ⅜"	16.4
10	G or NPT ½"	17.4
15	G or NPT ¾"	20.0
20	G or NPT 1"	20.0

4.2. Remote variant with junction box

Note:

- Further information on the dimensions of the Type SE58 transmitter can be found in **data sheet Type SE58** ▶.
- Dimensions in mm, unless otherwise stated

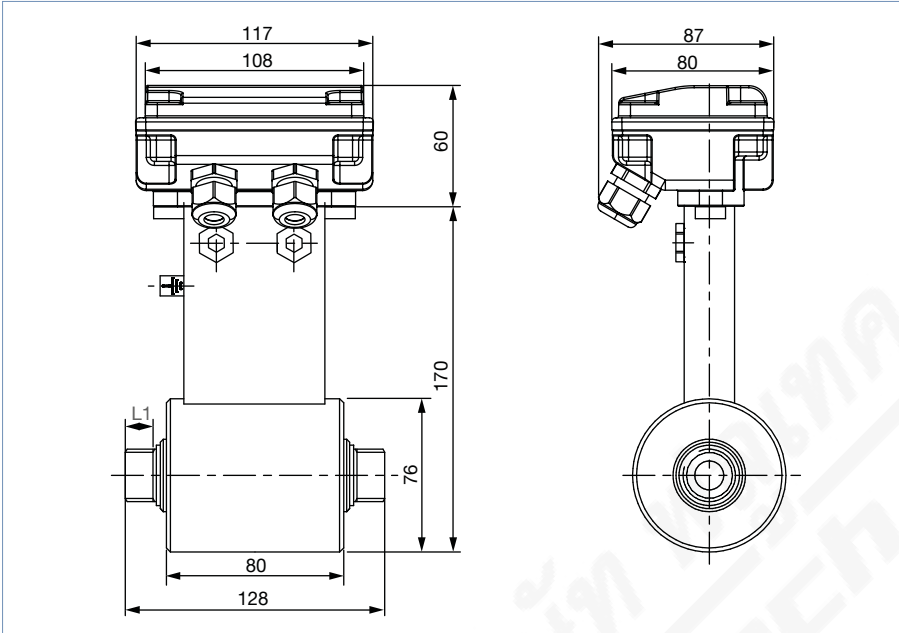

DN	Thread [Inch]	L1
03	G or NPT ¼"	16.4
06	G or NPT ⅜"	16.4
10	G or NPT ½"	17.4
15	G or NPT ¾"	20.0
20	G or NPT 1"	20.0

5. Product installation

5.1. Installation notes

Flow measurement

Note:

The device is not suitable for use in gaseous media and steam.

Minimum straight distances upstream and downstream of the sensor must be observed.

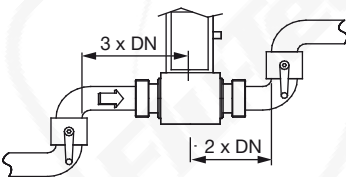

The device can be installed in either horizontal or vertical pipes, but following additional conditions should be respected:

- The pipe always has to be filled with fluid at all times near the device, when it is in operation.
- Mount the sensor in the indicated positions shown below to obtain an accurate flow measurement.

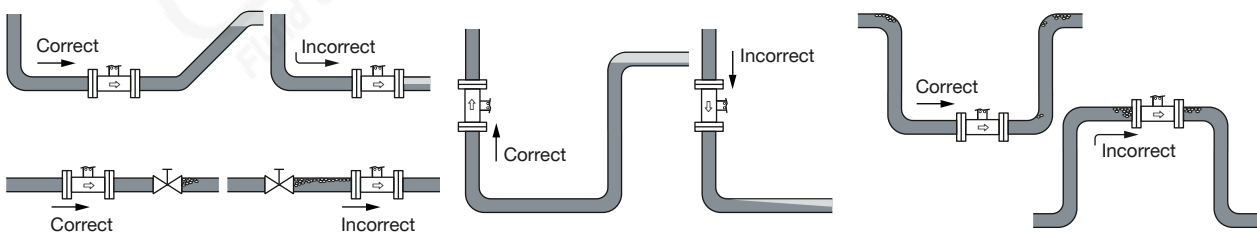

The suitable pipe size is selected using the diagram in the chapter "5.2. Selection of the nominal diameter" on page 7.

DTS 1000471655 EN Version: B Status: RL (released | freigegeben | valide) printed: 02.02.2024

5.2. Selection of the nominal diameter

The following graph is used to determine the appropriate DN of the pipe and fitting for the application, according to the fluid velocity and the flow rate. On the chart, the intersection of flow velocity and flow rate gives the appropriate diameter.

Example:

- Nominal flow: 10 l/min
 - Optimal flow rate: 2...3 m/s
- Result: Select a pipe size of DN 10

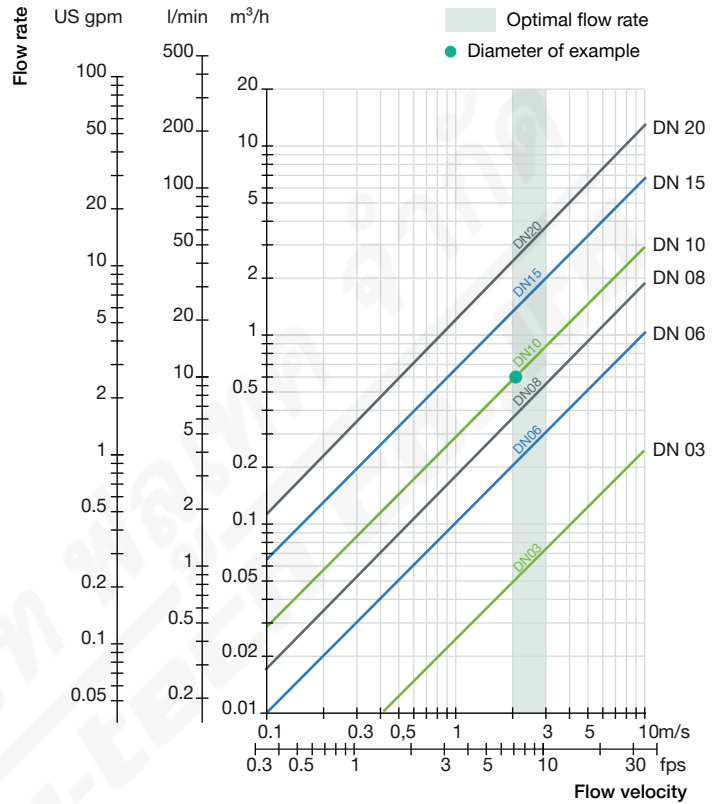

6. Product operation

6.1. Measuring principle

Faraday’s law serves as the physical basis for magnetic flow measurement.

Magnetic coils are arranged around the pipeline to generate a magnetic field. Conductive liquids flowing through the magnetic field induce a voltage at two opposite metallic electrodes in contact with the medium. These electrodes are used to measure the induced electrical alternating voltage.

The signal of sensor Type S051 must be amplified and processed by transmitter Type SE58.

Further information can be found in the data sheet of the transmitter, see [data sheet Type SE58](#) ▶.

7. Ordering information

7.1. Bürkert eShop



Bürkert eShop – Easy ordering and quick delivery

You want to find your desired Bürkert product or spare part quickly and order directly? Our online shop is available for you 24/7. Sign up and enjoy all the benefits.

[Order online now](#)

7.2. Recommendation regarding product selection

A complete flowmeter consists of a Type S051 flow sensor (compact or remote variant) and a Type SE58 transmitter (compact or remote variant).

See **data sheet Type SE58** ▶ for more information.

Two different components must be ordered in order to select a complete device. The following information is required:

- **Article no.** of the sensor **Type S051** (see **"7.4. Ordering chart" on page 8**)
- **Article no.** of the transmitter **Type SE58** (see **data sheet Type SE58** ▶ for more information)

7.3. Bürkert product filter



Bürkert product filter – Get quickly to the right product

You want to select products comfortably based on your technical requirements? Use the Bürkert product filter and find suitable articles for your application quickly and easily.

[Try out our product filter](#)

7.4. Ordering chart

DN [mm]	Flow rate range		Pipe connection	Material				Article no.
	Min. 0...0.4 m/s	Max. 0...10 m/s		Housing	Pipe connection / Electrode ¹⁾	Seal	Lining	
Sensor Type S051, compact variant								
03	0...10 l/h	0...250 l/h	G ¼" (ISO 228-1) NPT ¼"	Stainless steel 304	Stainless steel 316L	FKM	PTFE	554321
06	0...40 l/h	0...1000 l/h	G ⅜" (ISO 228-1)					554213
			NPT ⅜"					553065
10	0...120 l/h	0...3000 l/h	G ½" (ISO 228-1)					555892
			NPT ½"					553374
15	0...240 l/h	0...6000 l/h	G ¾" (ISO 228-1)					555111
			NPT ¾"	553481				
20	0...500 l/h	0...12500 l/h	G 1" (ISO 228-1)	557659				
			NPT 1"	553539				
								553663

DTS 1000471655 EN Version: B Status: RL (released | freigegeben | valide) printed: 02.02.2024

DN [mm]	Flow rate range		Pipe connection	Material				Article no.
	Min. 0...0.4 m/s	Max. 0...10 m/s		Housing	Pipe connection / Electrode ^{1.)}	Seal	Lining	
Sensor Type S051, remote variant with junction box in stainless steel 304 (1.4301) raw and 10 m electrodes and coils cables (included)								
03	0...10 l/h	0...250 l/h	G ¼" (ISO 228-1)	Stainless steel 304	Stainless steel 316L	FKM	PTFE	448487
06	0...40 l/h	0...1000 l/h	G ⅜" (ISO 228-1)					448488
10	0...120 l/h	0...3000 l/h	G ½" (ISO 228-1)					448489
15	0...240 l/h	0...6000 l/h	G ¾" (ISO 228-1)					448490
20	0...500 l/h	0...12500 l/h	G 1" (ISO 228-1)					448491

1.) 2 measuring electrodes

Further variants on request	
<p>Process connection</p> <ul style="list-style-type: none"> External thread: DIN 11851, SMS 1145 Clamp: ISO2852, BS 4825 Flange: DIN 2501, ANSI 	<p>Pressure PN 40</p>
<p>Material</p> <ul style="list-style-type: none"> Seal: EPDM, FFKM Junction box in painted aluminium or stainless steel 304 (1.4301) polished Wetted parts (connection): Stainless steel 304 (with full lining in PTFE) Electrodes: <ul style="list-style-type: none"> Alloy C (2 measuring electrodes + 2 ground electrodes) Titanium (2 measuring electrodes + 2 ground electrodes) Tantalum (2 measuring electrodes + 2 ground electrodes) Platinum-rhodium (2 measuring electrodes + 2 ground electrodes) 	

7.5. Ordering chart accessories

Accessories for remote sensor	No.	Description	Article no.
Without junction box 	1	10 m cable for electrodes ^{1.)} For connecting the sensor (variant without junction box) Type S051, S054, S055 or S056 to the connecting box of the extension cable set	448518
	2	10 m cable for coils ^{1.)} For connecting the sensor (variant without junction box) Type S051, S054, S055 or S056 to the connecting box of the extension cable set	448519
	3	10 m cable for electrodes ^{1.)} For connecting • the connecting box of the extension cable set to the transmitter Type SE58	562851
With junction box 	4	10 m cable for coils ^{1.)} For connecting • the connecting box of the extension cable set to the transmitter Type SE58 • the sensor (variant with junction box) Type S051, S054, S055 or S056 to the transmitter Type SE58	562852
	5	Connecting box of the extension cable set including resin	562853

1.) Cable lengths other than 10 m on request (for cables length >20 m, a preamplifier is supplied for an additional charge).

DTS 1000471655 EN Version: B Status: RL (released | freigegeben | valide) printed: 02.02.2024