



Inline flowmeter with paddle wheel, ELEMENT design

- Size of measurement pipes: DN 06...DN 65
- Configurable outputs: one or two transistor output(s) and one or two 4...20 mA current output(s)
- Removable backlit display/configuration module for indication of flow rate and volume with two flow totalizers
- Automatic calibration using Teach-In, all outputs can be checked without the need for actual flow

Product variants described in the data sheet may differ from the product presentation and description.

Can be combined with

- 
Type 8611 ▶
 eCONTROL - Universal controller
- 
Type 2030 ▶
 Pneumatically operated 2/2-way diaphragm valve CLASSIC with plastic valve body
- 
Type 2101 ▶
 Pneumatically operated 2/2-way globe valve ELEMENT for decentralised automation
- 
Type 8692 ▶
 Digital electro-pneumatic positioner for integrated mounting on process control valves
- 
Type 8644 ▶
 AirLINE SP electropneumatic automation system
- 
Type 8619 ▶
 multiCELL - Multi-channel and multi-function transmitter/controller

Type description

The paddle wheel device Type 8036 is specially designed for measuring the flow rate in solid-free liquids in a variety of applications (water, waste water monitoring, chemical processing, etc.).

The device is made up of a compact sensor-fitting with paddle wheel (Type S030) and a transmitter (Type SE36). The device is quickly and easily assembled thanks to a bayonet mounting and locking system. The Bürkert "Inline quarter-turn" technology ensures a leakage-free operation.

The Bürkert-designed sensor-fitting system ensures simple installation of the device into all pipelines from DN 06...DN 65.

The device is available either with 2 configurable outputs (1 transistor output (NPN) and (1 current output 4...20 mA, 2-wire), or with 3 configurable outputs (2 transistor outputs (NPN/PNP) and 1 current output 4...20 mA, 2-wire) or with 4 configurable outputs (2 transistor outputs (NPN/PNP) and (2 current outputs 4...20 mA, 3-wire).

The device converts the measured signal, displays different values in different units (if the display/configuration module is mounted) and computes the output signals which are provided via one or two M12 fixed connectors. Thanks to 1 or 2 transistor outputs, the flowmeter can be used to switch a solenoid valve, activate an alarm and, thanks to 1 or 2 current outputs, establish one or two control loops.

DTS 1000128709 EN Version: S Status: RL (released | freigegeben | valide) printed: 12.02.2024

FLU-TECH CO. LTD.

Email: sales@flutech.co.th **Website:** <https://flutech.co.th>

Tel: 02-384-6060, 086-369-5871-3 **Fax:** 02-384-5701 **LINE OA:** @flutech.co.th

Address (HQ): 845/3-4, Moo 3, Theparak Rd., T. Theparak, A. Mueang Samut Prakan, Samut Prakan, 10270, Thailand



Table of contents

1. General technical data	3
2. Approvals and conformities	5
2.1. General notes.....	5
2.2. Conformity	5
2.3. Standards.....	5
2.4. Pressure Equipment Directive (PED).....	5
Device used on a pipe	5
2.5. North America (USA/Canada)	6
3. Materials	6
3.1. Bürkert resistApp	6
3.2. Material specifications	6
4. Dimensions	7
4.1. Transmitter Type SE36	7
4.2. Transmitter Type SE36 mounted in an Inline sensor-fitting Type S030.....	7
5. Performance specifications	8
5.1. Pressure temperature diagram.....	8
6. Product installation	8
6.1. Installation notes	8
Flow measurement.....	8
7. Product operation	9
7.1. Measuring principle.....	9
8. Product design and assembly	10
8.1. Product assembly	10
9. Networking and combination with other Bürkert products	10
10. Ordering information	11
10.1. Bürkert eShop.....	11
10.2. Recommendation regarding product selection.....	11
10.3. Bürkert product filter.....	11
10.4. Ordering chart	12
Transmitter Type SE36	12
10.5. Ordering chart accessories.....	12

1. General technical data

Note:

If the device is mounted in a humid environment or outside, then the maximum voltage allowed is **35 V DC** instead of 36 V DC.

Product properties

Material

Make sure the device materials are compatible with the fluid you are using.

Further information can be found in chapter **"3.1. Bürkert resistApp"** on page 6.

Further information on the materials can be found in chapter **"3.2. Material specifications"** on page 6.

Non wetted parts

Cover	Polycarbonate (PC), transparent (opaque on request)
Housing	Stainless steel 1.4404 (316L), PPS
Screw	Stainless steel 1.4401 (316 (A4))
Grounding terminal and screw	Stainless steel 1.4301 (304 (A2))
Bayonet system	PC
Display/configuration module	PC
Navigation key	PBT
Seal	EPDM, silicone
Fixed connector holder	PPS CF30
Fixed connector	Nickel-plated brass (stainless steel on request)

Wetted parts

Sensor armature	Brass, stainless steel, PVC, PP or PVDF (depending on the Inline sensor-fitting variant Type S030)
Axis and bearing	Ceramics (Al ₂ O ₃)
Paddle wheel	PVDF
Sensor-fitting body	Brass, stainless steel, PVC, PP or PVDF (depending on the Inline sensor-fitting variant Type S030)
Seal	FKM or EPDM (depending on the Inline sensor-fitting variant Type S030)
Compatibility	Any pipe from DN 06...DN 65 which are fitted with Bürkert Type S030 Inline sensor-fitting. For the selection of the nominal diameter of the Inline sensor-fittings, see data sheet Type S030 ▶.
Pipe diameter	DN 06...DN 65
Dimensions	Further information can be found in chapter "4. Dimensions" on page 7
Measuring principle	Paddle wheel
Measuring range	<ul style="list-style-type: none"> Flow rate: 0.5...1200 l/min (0.13...320 gpm) Flow velocity: 0.3...10 m/s

Product accessory

Display/configuration module	Grey dot matrix 128 x 64 with backlighting
------------------------------	--

Performance data

Measurement deviation	Teach-In: $\pm 1\%$ of the measured value ¹⁾ at Teach-In flow rate value Standard K-factor: $\pm 2.5\%$ of the measured value ¹⁾
Linearity	$\pm 0.5\%$ of full scale ¹⁾
Repeatability	$\pm 0.4\%$ of the measured value ¹⁾
4...20 mA output uncertainty	$\pm 1\%$ of current range

Electrical data

Operating voltage	<ul style="list-style-type: none"> 2 or 3 outputs transmitter (2-wire) variant: 14...36 V DC, filtered and regulated 4 outputs transmitter (3-wire) variant: 12...36 V DC, filtered and regulated Connection to main supply: permanent (through external SELV (Safety Extra Low Voltage) and LPS (Limited Power Source) power supply)
Power source (not supplied)	Limited power source according to UL/EN 62368-1 standards or limited energy circuit according to UL/EN 61010-1 paragraph 9.4
DC reverse polarity protection	Yes
Overvoltage protection	Yes
Current consumption	With sensor <ul style="list-style-type: none"> ≤ 1 A (with transistors load) 2 or 3 outputs transmitter (2-wire) variant: ≤ 25 mA (at 14 V DC without transistors load, with current loop) 4 outputs transmitter (3-wire) variant: ≤ 5 mA (at 12 V DC without transistors load, without current loop)
Power consumption	Max. 40 W

Output	<ul style="list-style-type: none"> • Transistor (digital output): <ul style="list-style-type: none"> – 1 transistor output (transmitter 2-wire): <ul style="list-style-type: none"> – NPN, open collector – max. 700 mA – 1...36 V DC – 2 transistor outputs (transmitter 2 or 3-wire): <ul style="list-style-type: none"> – adjustable as sourcing or sinking (respectively both as PNP or NPN), open collector – max. 700 mA – 0.5 A max. per transistor if the 2 transistor outputs are wired – NPN-output: 1...36 V DC – PNP-output: Power supply • Current (analogue output): <ul style="list-style-type: none"> – 4...20 mA – adjustable as sourcing or sinking (in the same mode as transistor) – max. loop impedance: <ul style="list-style-type: none"> – 1 current output (transmitter 2-wire): 1100 Ω at 36 V DC, 610 Ω at 24 V DC, 180 Ω at 14 V DC – 2 current outputs (transmitter 3-wire): 1100 Ω at 36 V DC, 610 Ω at 24 V DC, 100 Ω at 12 V DC
--------	--

Voltage supply cable	<p>The female M12 connector and/or the male M12 connector are not included in the delivery and must be ordered separately, see chapter “10.5. Ordering chart accessories” on page 12. For these connectors, use a shielded cable with:</p> <ul style="list-style-type: none"> • diameter: 3...6.5 mm • cross section of wires: max. 0.75 mm²
----------------------	---

Medium data

Fluid temperature	<p>With Inline sensor-fitting Type S030 in:</p> <ul style="list-style-type: none"> • PVC: 0...+50 °C (+32...+122 °F) • PP: 0...+80 °C (+32...+176 °F) • PVDF, stainless steel or brass: -15...+100 °C (+5...+212 °F) <p>See data sheet Type S030 ▶ for more information.</p>
Fluid pressure (max.)	<p>With Inline sensor-fitting Type S030 in:</p> <ul style="list-style-type: none"> • plastic: max. PN 10 • metal: max. PN 16 (PN 40 on request) <p>See data sheet Type S030 ▶ for more information.</p>
Viscosity	Max. 300 cSt
Rate of solid particles	Max. 1 %
Maximum particle size	0.5 mm

Process/Pipe connection & communication

Pipe connection	<p>With Inline sensor-fitting Type S030 in:</p> <ul style="list-style-type: none"> • Plastic: true union with nut and solvent/fusion socket, spigot or external thread • Metal: internal or external thread, weld ends, clamp or flange <p>See data sheet Type S030 ▶ for more information.</p>
Electrical connection	<ul style="list-style-type: none"> • 2 or 3 outputs transmitter (2-wire) variant: 1 x 5-pin M12 male connector • 4 outputs transmitter (3-wire) variant: 1 x 5-pin M12 male and 1 x 5-pin M12 female connectors

Approvals and conformities

Directives	
CE directive	Further information on the CE Directive can be found in chapter “2.3. Standards” on page 5
Pressure equipment directive	Complying with article 4, paragraph 1 of 2014/68/EU directive Further information on the pressure equipment directive can be found in chapter “2.4. Pressure Equipment Directive (PED)” on page 5.
North America (USA/Canada)	UL Recognized for the USA and Canada

DTS 1000128709 EN Version: S Status: RL (released | freigegeben | validé) printed: 12.02.2024

Environment and installation	
Ambient temperature	Operation and storage: - 10...+60 °C (+ 14...+ 140 °F)
Relative air humidity	≤ 85 %, without condensation
Height above sea level	Max. 2000 m
Operating condition	Continuous
Equipment mobility	Fixed
Application range	Indoor and outdoor Protect the device against electromagnetic interference, ultraviolet rays and, when installed outdoors, against the effects of climatic conditions.
Degree of protection ^{2.)}	IP65, IP67 (according to EN60529), NEMA 4X (according to NEMA250) under the following simultaneous conditions: <ul style="list-style-type: none"> • device wired • cover screwed tight • M12 connector mounted and tightened
Installation category	Category I according to UL/EN 61010-1
Pollution degree	Degree 2 according to UL/EN 61010-1

1.) Under reference conditions i.e. measuring medium = water, ambient and water temperature = +20 °C (+68 °F), observing the minimum the minimum inlet and outlet sections and the appropriate inner diameter of the pipe.

2.) Not evaluated by UL

2. Approvals and conformities

2.1. General notes

- The approvals and conformities listed below must be stated when making enquiries. This is the only way to ensure that the product complies with all required specifications.
- Not all available variants of the device can be supplied with the below mentioned approvals or conformities.

2.2. Conformity

In accordance with the Declaration of Conformity, the product is compliant with the EU Directives.

2.3. Standards

The applied standards which are used to demonstrate compliance with the EU Directives are listed in the EU-Type Examination Certificate and/or the EU Declaration of Conformity.

2.4. Pressure Equipment Directive (PED)

The device conforms to article 4, paragraph 1 of the Pressure Equipment Directive (PED) 2014/68/EU under the following conditions:

Device used on a pipe

Note:

- The data in the table is independent of the chemical compatibility of the material and the fluid.
- PS = maximum admissible pressure (in bar), DN = nominal diameter of the pipe

Type of fluid	Conditions
Fluid group 1, article 4, paragraph 1.c.i	DN ≤ 25
Fluid group 2, article 4, paragraph 1.c.i	DN ≤ 32 or PS*DN ≤ 1000
Fluid group 1, article 4, paragraph 1.c.ii	DN ≤ 25 or PS*DN ≤ 2000
Fluid group 2, article 4, paragraph 1.c.ii	DN ≤ 200 or PS ≤ 10 or PS*DN ≤ 5000

DTS 1000128709 EN Version: S Status: RL (released | freigegeben | valide) printed: 12.02.2024

2.5. North America (USA/Canada)

Approval	Description
	<p>Optional: UL Recognized for the USA and Canada The products are UL Recognized for the USA and Canada according to:</p> <ul style="list-style-type: none"> • UL 61010-1 • CAN/CSA-C22.2 No. 61010-1

3. Materials

3.1. Bürkert resistApp



Bürkert resistApp – Chemical resistance chart

You want to ensure the reliability and durability of the materials in your individual application case? Verify your combination of media and materials on our website or in our resistApp.

[Start chemical resistance check](#)

3.2. Material specifications

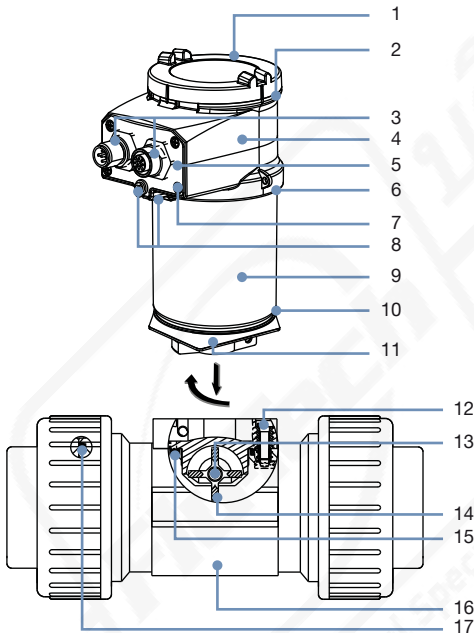

No.	Element	Material
1	Cover	PC
2	Seal	Silicone
3	Connector (female /male M12)	Nickel-plated brass
4	Housing (top)	PPS
5	Connector holder	PPS CF30
6	Seal	EPDM
7	Screws	Stainless steel 1.4301 (304 (A2))
8	Grounding terminal and screw	Stainless steel 1.4401 (316 (A4))
9	Housing (body)	Stainless steel 1.4404 (316L)
10	Seal	EPDM
11	Housing (base)	PPS
12	Screws	Stainless steel 1.4301 (304 (A2))
13	Axis and bearings	Ceramics (Al ₂ O ₃)
14	Paddle wheel	PVDF
15	Seal	FKM or EPDM (depending on the sensor-fitting variant S030)
16	Sensor-fitting body	Stainless steel 1.4404 (316L), brass, PVC, PP, PVDF (depending on S030 variant)
17	Seals	FKM or EPDM (depending on S030 variant and only for true union connection with nut and solvent/fusion socket)

DTS 1000128709 EN Version: S Status: RL (released | freigegeben | valide) printed: 12.02.2024

4. Dimensions

4.1. Transmitter Type SE36

Note:

Dimensions in mm, unless otherwise stated

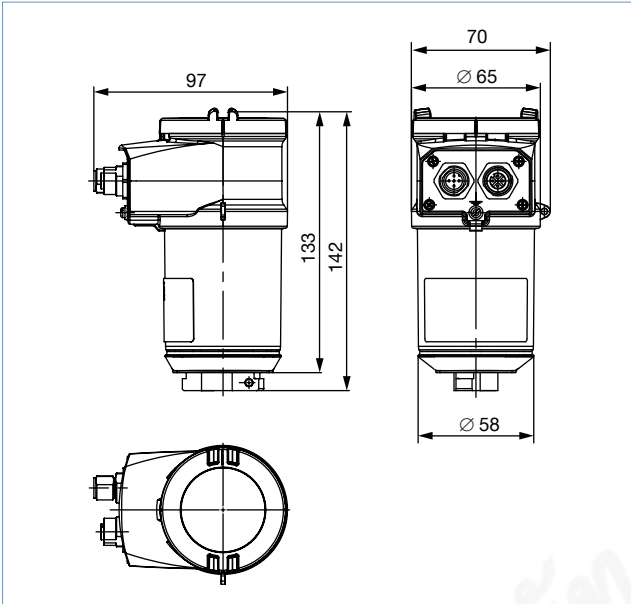

4.2. Transmitter Type SE36 mounted in an Inline sensor-fitting Type S030

Note:

Dimensions in mm, unless otherwise stated

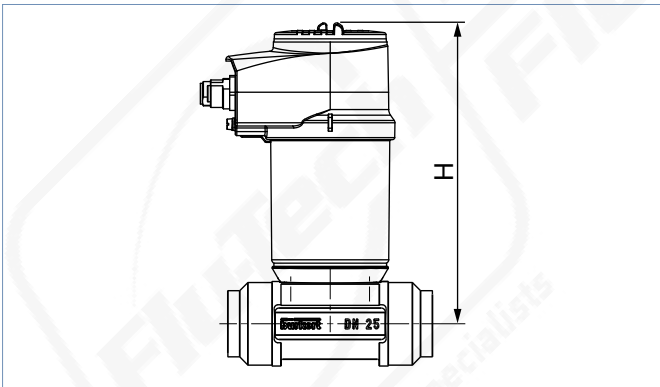

DN	H
06	162
08	162
15	167
20	165
25	165
32	168
40	172
50	179
65	179

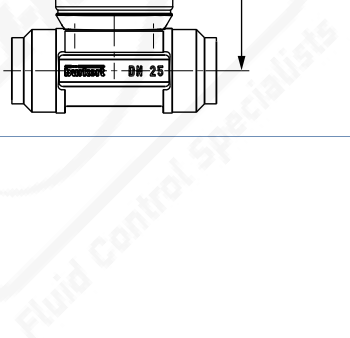

5. Performance specifications

5.1. Pressure temperature diagram

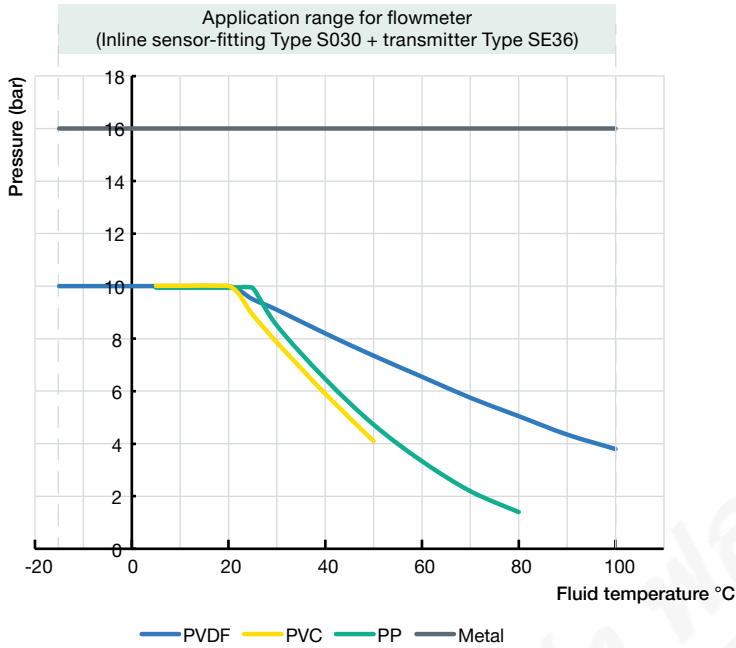

6. Product installation

6.1. Installation notes

Flow measurement

Note:

The device is not suitable for use in gaseous media and steam.

Minimum straight distances upstream and downstream of the sensor must be observed. These stabilizing distances depend on the pipe's design. Increasing these distances or installing a flow conditioner may be necessary to obtain the best accuracy. For more information, refer to EN ISO 5167-1.

EN ISO 5167-1 specifies the straight inlet and outlet distances that must be complied with when installing fittings in pipe lines in order to achieve calm flow conditions. The most commonly used elements that could lead to turbulence in the flow are shown below. The related minimum inlet and outlet distances that ensure a calm flow are also specified.

Make sure that the measuring conditions at the point of measurement are calm and problem-free.

DN = Orifice

Fluid direction ⇨

Regulating valve¹⁾

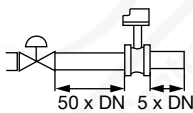

2 x 90° elbow joint

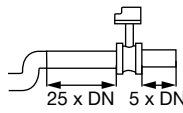

Expansion²⁾

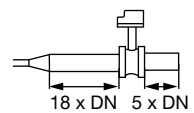

2 x 90° elbow joint
3 dimensional

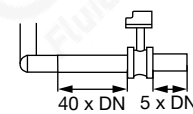

90° elbow joint
or T-piece

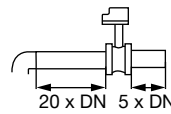

Reduction

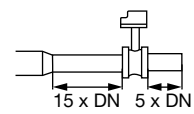

1.) If the valve cannot be mounted after the measuring device, the minimal distances have to be respected.

2.) If an expansion cannot be avoided, the minimal distances have to be respected.

Please note minimum flow velocity

The device can be installed in either horizontal or vertical pipes, but following additional conditions should be respected:

- The pipe always has to be filled with fluid at all times near the device.
- The pipe design must be such that no air bubbles or cavitation can form within the medium near the device at any time.

The flowmeter can be installed into either horizontal or vertical pipes.

Important criteria for this are; ensure that the measurement pipe is fully filled and that the measurement pipe is air bubble free.

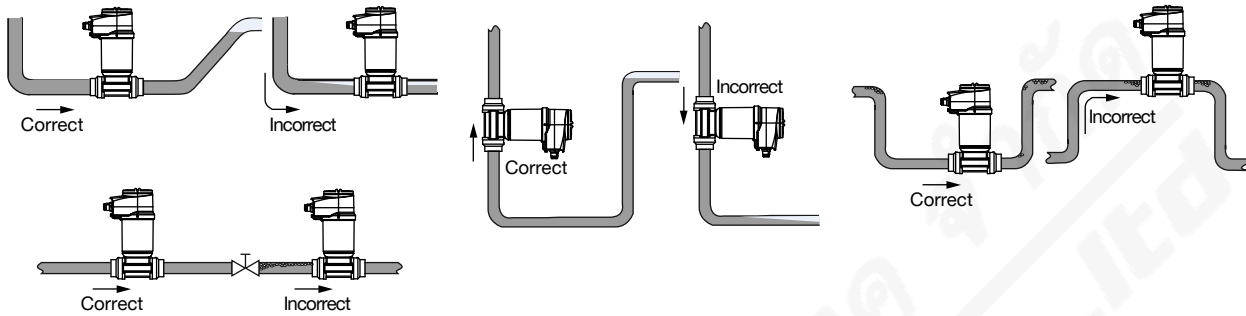

Pressure and temperature ratings must be respected according to the selected fitting material. The suitable pipe size is selected using the diagram in the chapter “Nominal size selection” of the **data sheet Type S030** ▶.

7. Product operation

7.1. Measuring principle

When liquid flows through the pipe, the paddle wheel with 4 inserted magnets is set in rotation, producing a measuring signal in the sensor (coil or Hall sensor depending on variant). The frequency modulated induced voltage is proportional to the flow velocity of the fluid. A K factor, specific to each pipe, enables the conversion of this frequency into a flow rate/volume.

This K factor is available in the fittings' operating instructions, see **Type S030** ▶.

The electronic component converts the measured signal into several outputs (according to the device variant) and displays the actual value. Totalizers are used to obtain the volume of fluid passed through the pipe.

The electrical connection is provided via a male connector or via male connector M12 and a female connector M12, depending on variant.

8. Product design and assembly

8.1. Product assembly

Note:

- The device Type 8036 is made up of a Bürkert Inline sensor-fitting Type S030 equipped with a paddle wheel sensor and a transmitter Type SE36.
- The Inline sensor-fitting Type S030 ensures simple installation into pipes from DN 06...DN 65. The transmitter Type SE36 can easily be installed into any sensor-fitting system Type S030, by means of a bayonet fastening, see **data sheet Type S030** ▶ for more information.

The housing of the device contains the electronic module and a removable display/configuration module.

The device operates without the display/configuration module, but it is required for device configuration (i.e. set or restore parameters, configure information to be displayed, enter access codes...) and also for visualizing continuously the measured and processed data.

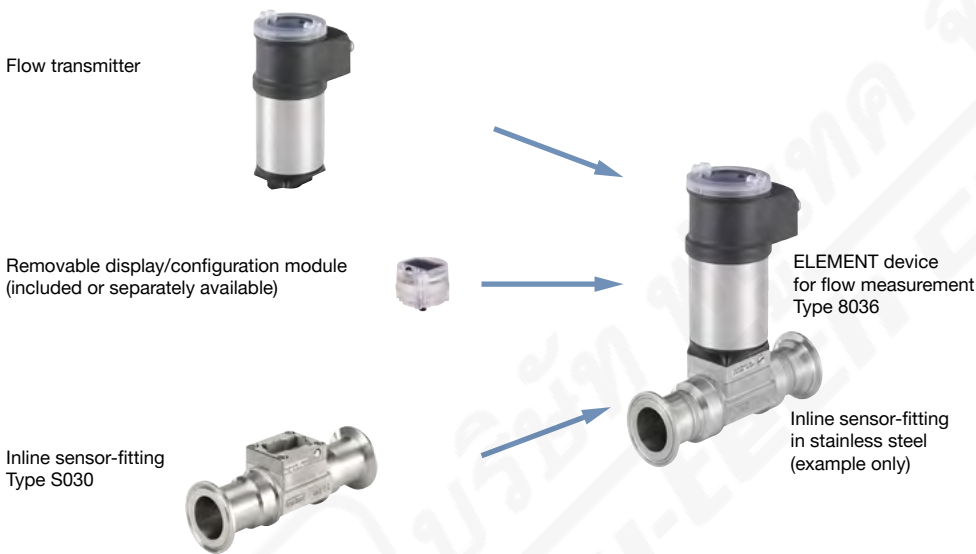

9. Networking and combination with other Bürkert products

Example:



DTS 1000128709 EN Version: S Status: RL (released | freigegeben | validé) printed: 12.02.2024

10. Ordering information

10.1. Bürkert eShop



Bürkert eShop – Easy ordering and quick delivery

You want to find your desired Bürkert product or spare part quickly and order directly? Our online shop is available for you 24/7. Sign up and enjoy all the benefits.

[Order online now](#)

10.2. Recommendation regarding product selection

Note:

When only ordering devices without a display/configuration module, make sure that you have a display/configuration module at least for parameterising the device. Otherwise you must also order one (see chapter “10.5. Ordering chart accessories” on page 12).

A flowmeter Type 8036 consists of a compact flow transmitter Type SE36, a removable display/configuration module and a Bürkert Inline sensor-fitting Type S030.

See **data sheet Type S030** ▶ for more information.

Two or three different components must be ordered in order to select a complete device. The following information is required:

- **Article no.** of the compact Type SE36 flow transmitter available with or without display/configuration module (see chapter “10.4. Ordering chart” on page 12)
- **Article no.** of the removable display/configuration module, if necessary (see chapter “10.5. Ordering chart accessories” on page 12)
- **Article no.** of the selected Type S030 Inline sensor-fitting (see **data sheet Type S030** ▶)

10.3. Bürkert product filter



Bürkert product filter – Get quickly to the right product

You want to select products comfortably based on your technical requirements? Use the Bürkert product filter and find suitable articles for your application quickly and easily.

[Try out our product filter](#)

DTS 1000128709 EN Version: S Status: RL (released | freigegeben | validé) printed: 12.02.2024

10.4. Ordering chart

Transmitter Type SE36

Note:

- All settings as well as the digital output have to be configured with the display/configuration module (must be ordered separately).
- The following article no.s. have a transparent cover as standard.

Operating voltage	Output	UL approval	Electrical connection ¹⁾	Article no.	
				Without display/ configuration module	With display/ configuration module
14...36 V DC	2 outputs: 1 x transistor NPN + 1 x 4...20 mA (2 wires)	–	5-pin M12 male connector	560880 ☒	561880 ☒
		UL-Recognized		560883 ☒	561883 ☒
	3 outputs: 2 x transistors NPN/PNP + 1 x 4...20 mA (2 wires)	–		560881 ☒	561881 ☒
		UL-Recognized		560884 ☒	561884 ☒
12...36 V DC	4 outputs: 2 x transistors NPN/PNP + 2 x 4...20 mA (3 wires)	–	5-pin M12 male and 5-pin M12 female connectors	560882 ☒	561882 ☒
		UL-Recognized		560885 ☒	561885 ☒

1.) Must be ordered separately (see chapter "11.5. Ordering chart accessories" on page 10): M12 male/female connectors (only 1 M12 female for the variant with one 4...20 mA output, 1 M12 male and 1 M12 female for the variant with two 4...20 mA outputs of the device)

10.5. Ordering chart accessories

Description	Article no.
Spare part	
Opaque cover with seal (1 screw cover with EPDM seal + 1 quarter turn closing cover with silicone seal)	560948 ☒
Transparent cover with seal (1 screw cover with EPDM seal + 1 quarter turn closing cover with silicone seal)	561843 ☒
Electrical connection	
M12 female connector with plastic threaded clamping ring, 5-pin, straight, to be wired	917116 ☒
M12 male connector with plastic threaded clamping ring, 5-pin, straight, to be wired	560946 ☒
M12 female connector with moulded cable (shielded), 5-pin, straight, cable length: 2 m	438680 ☒
M12 male connector with moulded cable (shielded), 5-pin, straight, cable length: 2 m	559177 ☒
Configuration accessory	
Removable display/configuration module (with instruction sheet)	559168 ☒

DTS 1000128709 EN Version: S Status: RL (released | freigegeben | validé) printed: 12.02.2024