



Insertion flowmeter with paddle wheel, ELEMENT design

- Up to PN 10, size of measurement pipes: DN 20...DN 400
- Configurable outputs: one or two transistor output(s) and one or two 4...20 mA current output(s)
- Removable backlit display/configuration module for indication of flow rate and volume with two flow totalizers
- Automatic calibration using teach-in, all outputs can be checked without the need for actual flow

Product variants described in the data sheet may differ from the product presentation and description.

Can be combined with

- | | |
|--|--|
| | Type 8692 ▶ Digital electro-pneumatic positioner for integrated mounting on process control valves |
| | Type 2030 ▶ Pneumatically operated 2/2-way diaphragm valve CLASSIC with plastic valve body |
| | Type 8644 ▶ AirLINE SP electropneumatic automation system |
| | Type 2101 ▶ Pneumatically operated 2/2-way globe valve ELEMENT for decentralised automation |
| | Type 8611 ▶ eCONTROL - Universal controller |
| | Type S020 ▶ Insertion fitting for flow or analytical measurement |
| | Type 8619 ▶ multiCELL - Multi-channel and multi-function transmitter/controller |

Type description

The device Type 8026 is specially designed for measuring the flow rate in solid-free liquids in a variety of applications (water treatment, waste water monitoring, chemical processing, etc.). The Bürkert-designed fitting system ensures simple installation of the device into all pipes from DN 20...DN 400.

The device is provided either with 2 configurable outputs (1 transistor output (NPN) and (1 current output 4...20 mA, 2-wire), or with 3 configurable outputs (2 transistor outputs (NPN/PNP) and 1 current output 4...20 mA, 2-wire) or with 4 configurable outputs (2 transistor outputs (NPN/PNP) and (2 current outputs 4...20 mA, 3-wire).

The device converts the measured signal, displays different values in different units (if the display/configuration module is mounted) and computes the output signals which are provided via one or two M12 fixed connectors. Thanks to 1 or 2 transistor outputs, the flowmeter can be used to switch a solenoid valve, activate an alarm and, thanks to 1 or 2 current outputs, establish one or two control loops.

DTS 1000128706 EN Version: Q Status: RL (released | freigegeben | validé) printed: 11.12.2023

FLU-TECH CO. LTD.

Email: sales@flutech.co.th **Website:** https://flutech.co.th

Tel: 02-384-6060, 086-369-5871-3 **Fax:** 02-384-5701 **LINE OA:** @flutech.co.th

Address (HQ): 845/3-4, Moo 3, Theparak Rd., T. Theparak, A. Mueang Samut Prakan, Samut Prakan, 10270, Thailand



Table of contents

| | |
|---|-----------|
| 1. General technical data | 3 |
| 2. Approvals and conformities | 5 |
| 2.1. General notes..... | 5 |
| 2.2. Conformity | 5 |
| 2.3. Standards..... | 5 |
| 2.4. Pressure Equipment Directive (PED)..... | 5 |
| Device used on a pipe | 5 |
| 2.5. North America (USA/Canada) | 5 |
| 3. Materials | 6 |
| 3.1. Bürkert resistApp | 6 |
| 3.2. Material specifications | 6 |
| 4. Dimensions | 7 |
| 4.1. Flowmeter | 7 |
| 4.2. Flowmeter installed in an Insertion fitting Type S020 | 8 |
| 5. Performance specifications | 8 |
| 5.1. Pressure temperature diagram..... | 8 |
| 6. Product installation | 9 |
| 6.1. Installation notes | 9 |
| 7. Product operation | 10 |
| 7.1. Measuring principle..... | 10 |
| 8. Product design and assembly | 10 |
| 8.1. Product assembly | 10 |
| 9. Networking and combination with other Bürkert products | 11 |
| 9.1. Combination of the device with available Type S020 Insertion fittings DN | 11 |
| 10. Ordering information | 11 |
| 10.1. Bürkert eShop..... | 11 |
| 10.2. Recommendation regarding product selection..... | 12 |
| 10.3. Bürkert product filter..... | 12 |
| 10.4. Ordering chart..... | 12 |
| 10.5. Ordering chart accessories..... | 13 |

1. General technical data

Note:

If the device is mounted in a humid environment or outside, then the maximum voltage allowed is **35 V DC** instead of 36 V DC.

Product properties

Material

Make sure the device materials are compatible with the fluid you are using.

Further information can be found in chapter **"3.1. Bürkert resistApp"** on page 6.

Further information on the materials can be found in chapter **"3.2. Material specifications"** on page 6.

Non wetted parts

| | |
|------------------------------|---|
| Cover | Polycarbonate (PC), transparent (opaque on request) |
| Housing | Stainless steel 1.4404, PPS |
| Screw | Stainless steel 1.4401 (316 (A4)) |
| Grounding terminal and screw | Stainless steel 1.4301 (304 (A2)) |
| Display/configuration module | PC |
| Menu key | PBT |
| Union nut | PC |
| Seal | EPDM, silicone |
| Fixed connector holder | PPS CF30 |
| Fixed connector | Nickel-plated brass (stainless steel on request) |

Wetted parts

| | |
|---------------------|---|
| Sensor armature | PVDF |
| Axis and bearing | Ceramics (Al ₂ O ₃) |
| Paddle wheel | PVDF |
| Seal | FKM standard (EPDM included, but not mounted) |
| Compatibility | Any pipe from DN 20 ¹⁾ ...DN 400 which is fitted with Bürkert Type S020 Insertion fitting. For the selection of the nominal diameter of the fittings, see data sheet Type S020 ▶ |
| Pipe diameter | DN 20 ¹⁾ ...DN 400 |
| Dimensions | Further information can be found in chapter "4. Dimensions" on page 7. |
| Measuring principle | Paddle wheel |
| Measuring range | <ul style="list-style-type: none"> Flow rate: 0.5...75000 l/min (0.13...19813 gpm) Flow velocity: 0.3...10 m/s |

Product accessory

| | |
|------------------------------|--|
| Display/configuration module | Grey dot matrix 128 x 64 with backlighting |
|------------------------------|--|

Performance data

| | |
|------------------------------|--|
| Measurement deviation | <ul style="list-style-type: none"> Teach-in: $\pm 1\%$ of the measured value²⁾ at teach flow rate value Standard K factor: $\pm 2.5\%$ of the measured value²⁾ |
| Linearity | $\pm 0.5\%$ of full scale ²⁾ |
| Repeatability | $\pm 0.4\%$ of the measured value ²⁾ |
| 4...20 mA output uncertainty | $\pm 1\%$ of current range |

Electrical data

| | |
|--------------------------------|--|
| Operating voltage | <ul style="list-style-type: none"> 2 or 3 outputs transmitter (2-wire) variant: 14...36 V DC, filtered and regulated 4 outputs transmitter (3-wire) variant: 12...36 V DC, filtered and regulated Connection to main supply: permanent, through external SELV (Safety Extra Low Voltage) and LPS (Limited Power Source) power supply |
| Power source (not supplied) | Limited power source according to UL/EN 62368-1 standards or limited energy circuit according to UL/EN 61010-1 paragraph 9.4 |
| DC reverse polarity protection | Yes |
| Overvoltage protection | Yes |
| Current consumption | With sensor <ul style="list-style-type: none"> ≤ 1 A (with transistors load) 2 or 3 outputs transmitter (2-wire) variant: ≤ 25 mA (at 14 V DC without transistors load, with current loop) 4 outputs transmitter (3-wire) variant: ≤ 5 mA (at 12 V DC without transistors load, without current loop) |
| Power consumption | Max. 40 W |

| | |
|--------|--|
| Output | <ul style="list-style-type: none"> • Transistor (digital output): <ul style="list-style-type: none"> – 1 transistor output (transmitter 2-wire): <ul style="list-style-type: none"> – NPN, open collector – max. 700 mA – 1...36 V DC – 2 transistor outputs (transmitter 2 or 3-wire): <ul style="list-style-type: none"> – adjustable as sourcing or sinking (respectively both as PNP or NPN), open collector – max. 700 mA – 0.5 A max. per transistor if the 2 transistor outputs are wired – NPN-output: 1...36 V DC – PNP-output: Power supply • Current (analogue output): <ul style="list-style-type: none"> – 4...20 mA – adjustable as sourcing or sinking (in the same mode as transistor) – max. loop impedance: <ul style="list-style-type: none"> – 1 current output (transmitter 2-wire): 1100 Ω at 36 V DC, 610 Ω at 24 V DC, 180 Ω at 14 V DC – 2 current outputs (transmitter 3-wire): 1100 Ω at 36 V DC, 610 Ω at 24 V DC, 100 Ω at 12 V DC |
|--------|--|

| | |
|----------------------|--|
| Voltage supply cable | <p>The female M12 connector and/or the male M12 connector are not included in the delivery and must be ordered separately, see chapter “10.5. Ordering chart accessories” on page 13. For these connectors, use a shielded cable with:</p> <ul style="list-style-type: none"> • diameter: 3...6.5 mm • cross section of wires: max. 0.75 mm² |
|----------------------|--|

Medium data

| | |
|-------------------------|--|
| Fluid temperature | <p>With fitting Type S020 in:</p> <ul style="list-style-type: none"> • PVC: 0...+50 °C (+32...+122 °F) • PP: 0...+80 °C (+32...+176 °F) • PVDF, stainless steel or brass: -15...+100 °C (+5...+212 °F) <p>See data sheet Type S020 ► for more information.</p> |
| Fluid pressure | <p>Max. PN 10 (145 PSI) See data sheet Type S020 ► for more information.</p> |
| Viscosity | Max. 300 cSt |
| Rate of solid particles | Max. 1 % |
| Maximum particle size | 0.5 mm |

Process/Pipe connection & communication

| | |
|-----------------------|---|
| Process connection | <p>G 2" for use with Type S020 Insertion fitting See data sheet Type S020 ► for more information.</p> |
| Electrical connection | <ul style="list-style-type: none"> • 2 or 3 outputs transmitter (2-wire) variant: 1 x 5-pin M12 male connector • 4 outputs transmitter (3-wire) variant: 1 x 5-pin M12 male and 1 x 5-pin M12 female connectors |

Approvals and conformities

| | |
|------------------------------|--|
| Directives | |
| CE directive | Further information on the CE directive can be found in chapter “2.2. Standards” on page 5. |
| Pressure equipment directive | <p>Complying with article 4, paragraph 1 of 2014/68/EU directive Further information on the pressure equipment directive can be found in chapter “2.3. Pressure Equipment Directive (PED)” on page 5.</p> |
| North America (USA/Canada) | UL Recognized for the USA and Canada |

Environment and installation

| | |
|------------------------|---|
| Ambient temperature | Operation and storage: -10...+60 °C (+14...+140 °F) |
| Relative air humidity | ≤85 %, without condensation |
| Height above sea level | Max. 2000 m |
| Operating condition | Continuous |
| Equipment mobility | Fixed |
| Application range | <p>Indoor and outdoor Protect the device against electromagnetic interference, ultraviolet rays and, when installed outdoors, against the effects of climatic conditions.</p> |

DTS 1000128706 EN Version: Q Status: RL (released | freigegeben | validé) printed: 11.12.2023

| | |
|-------------------------------------|---|
| Degree of protection ^{3.)} | IP65, IP67 (according to EN60529), NEMA 4X (according to NEMA250) under the following simultaneous conditions: <ul style="list-style-type: none"> • device wired • cover screwed tight • M12 connector mounted and tightened |
| Installation category | Category I according to UL/EN 61010-1 |
| Pollution degree | Degree 2 according to UL/EN 61010-1 |

- 1.) Restricted to some Insertion fitting process connections
 2.) Under reference conditions i.e. measuring medium = water, ambient and water temperature = +20 °C (+68 °F), observing the minimum the minimum inlet and outlet sections and the appropriate inner diameter of the pipe.
 3.) Not evaluated by UL

2. Approvals and conformities

2.1. General notes

- The approvals and conformities listed below must be stated when making enquiries. This is the only way to ensure that the product complies with all required specifications.
- Not all available variants of the device can be supplied with the below mentioned approvals or conformities.

2.2. Conformity

In accordance with the Declaration of Conformity, the product is compliant with the EU Directives.

2.3. Standards

The applied standards which are used to demonstrate compliance with the EU Directives are listed in the EU-Type Examination Certificate and/or the EU Declaration of Conformity.

2.4. Pressure Equipment Directive (PED)

The device conforms to article 4, paragraph 1 of the Pressure Equipment Directive (PED) 2014/68/EU under the following conditions:

Device used on a pipe

Note:

- The data in the table is independent of the chemical compatibility of the material and the fluid.
- PS = maximum admissible pressure (in bar), DN = nominal diameter of the pipe

| Type of fluid | Conditions |
|--|-------------------------------------|
| Fluid group 1, article 4, paragraph 1.c.i | DN ≤ 25 |
| Fluid group 2, article 4, paragraph 1.c.i | DN ≤ 32 or PS*DN ≤ 1000 |
| Fluid group 1, article 4, paragraph 1.c.ii | DN ≤ 25 or PS*DN ≤ 2000 |
| Fluid group 2, article 4, paragraph 1.c.ii | DN ≤ 200 or PS ≤ 10 or PS*DN ≤ 5000 |

2.5. North America (USA/Canada)

| Approval | Description |
|----------|---|
| | <p>Optional: UL Recognized for the USA and Canada The products are UL Recognized for the USA and Canada according to:</p> <ul style="list-style-type: none"> • UL 61010-1 • CAN/CSA-C22.2 No. 61010-1 |

DTS 1000128706 EN Version: Q Status: RL (released | freigegeben | validé) printed: 11.12.2023

3. Materials

3.1. Bürkert resistApp

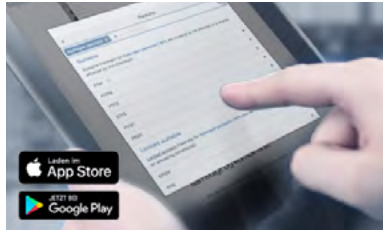

Bürkert resistApp – Chemical resistance chart

You want to ensure the reliability and durability of the materials in your individual application case? Verify your combination of media and materials on our website or in our resistApp.

[Start chemical resistance check](#)

3.2. Material specifications

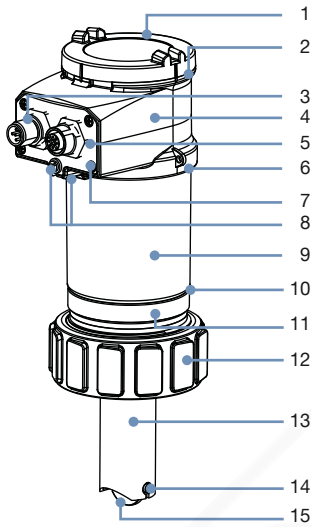

| No. | Element | Material |
|-----|---------------------------------------|--|
| 1 | Cover | PC |
| 2 | Seal | Silicone |
| 3 | Circular connector (female /male M12) | Nickel-plated brass |
| 4 | Housing (top) | PPS |
| 5 | Connector holder | PPS CF30 |
| 6 | Seal | EPDM |
| 7 | Screws | Stainless steel 1.4301 (304 (A2)) |
| 8 | Grounding terminal and screw | Stainless steel 1.4401 (316 (A4)) |
| 9 | Housing (body) | Stainless steel |
| 10 | Seal | EPDM |
| 11 | Housing (base) | PPS |
| 12 | Union nut | PC |
| 13 | Sensor armature | PVDF |
| 14 | Axis and bearing | Ceramics (Al ₂ O ₃) |
| 15 | Paddle wheel | PVDF |

4. Dimensions

4.1. Flowmeter

Note:

- Dimensions in mm, unless otherwise stated
- The length of the flow probe depends on the used Insertion fitting Type S020 and its nominal diameter, see **data sheet Type S020** ▶ for more information.

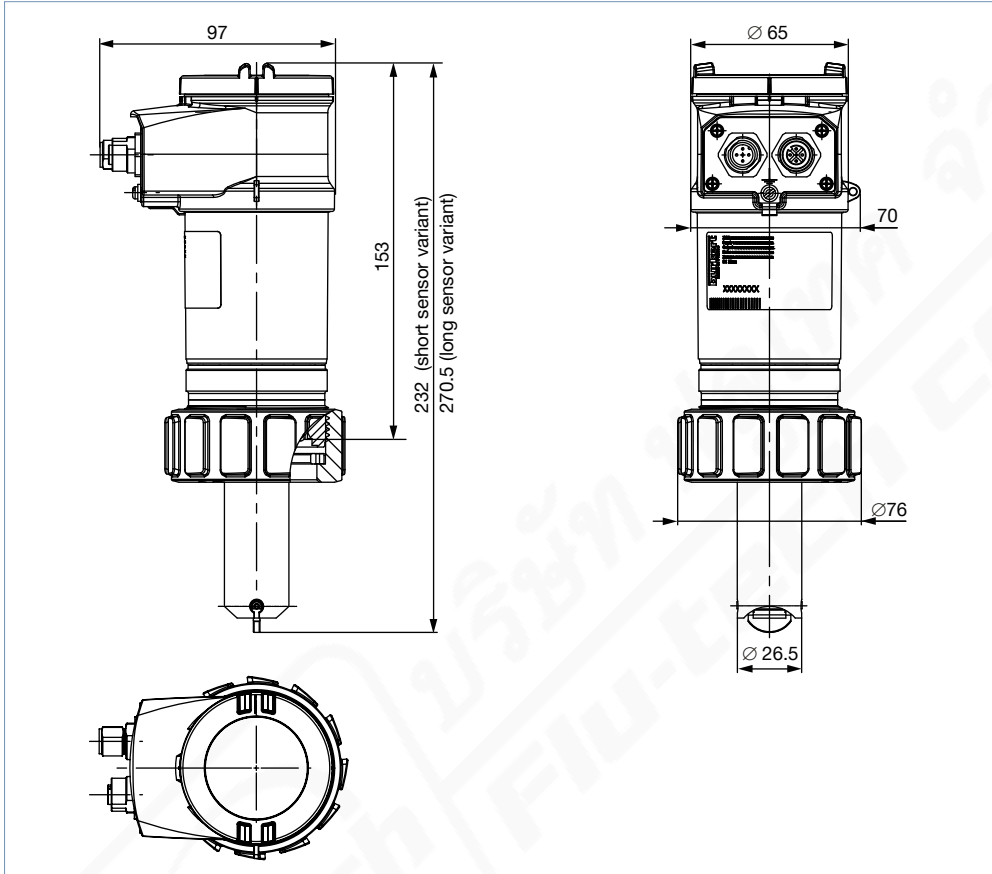

4.2. Flowmeter installed in an Insertion fitting Type S020

Note:

Dimensions in mm, unless otherwise stated

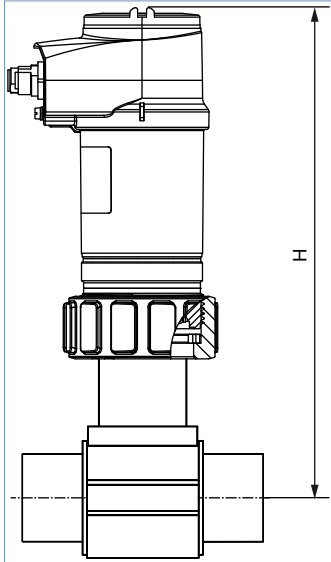

| DN | H | | | |
|-----|-----------|--------|----------------|--------------|
| | T-Fitting | Saddle | Plastic spigot | Metal spigot |
| 20 | 231.5 | - | - | - |
| 25 | 231.5 | - | - | - |
| 32 | 234.5 | - | - | - |
| 40 | 238.5 | - | - | - |
| 50 | 244.5 | 269.5 | - | 239.5 |
| 65 | 244.5 | 267.5 | 252.5 | 245.5 |
| 80 | - | 272.5 | 258.5 | 250.5 |
| 100 | - | 277.5 | 265.5 | 260.5 |
| 110 | - | 273.5 | - | - |
| 125 | - | 280.5 | 300.5 | 271.5 |
| 150 | - | 250.5 | 307.5 | 282.5 |
| 180 | - | 314.5 | - | - |
| 200 | - | 326.5 | 328.5 | 303.5 |
| 250 | - | - | 346.5 | 363.5 |
| 300 | - | - | 358.5 | 382.5 |
| 350 | - | - | 371.5 | 394.5 |
| 400 | - | - | 386.5 | - |

5. Performance specifications

5.1. Pressure temperature diagram

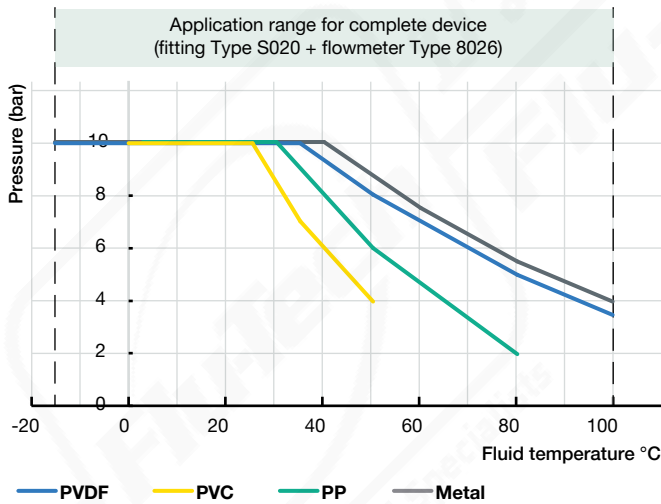

DTS 1000128706 EN Version: Q Status: RL (released | freigegeben | valide) printed: 11.12.2023

6. Product installation

6.1. Installation notes

Note:

The device is not suitable for use in gaseous media and steam.

Minimum straight distances upstream and downstream of the sensor must be observed. These stabilizing distances depend on the pipe's design. Increasing these distances or installing a flow conditioner may be necessary to obtain the best accuracy. For more information, refer to EN ISO 5167-1.

EN ISO 5167-1 specifies the straight inlet and outlet distances that must be complied with when installing fittings in pipe lines in order to achieve calm flow conditions. The most commonly used elements that could lead to turbulence in the flow are shown below. The related minimum inlet and outlet distances that ensure a calm flow are also specified.

Make sure that the measuring conditions at the point of measurement are calm and problem-free.

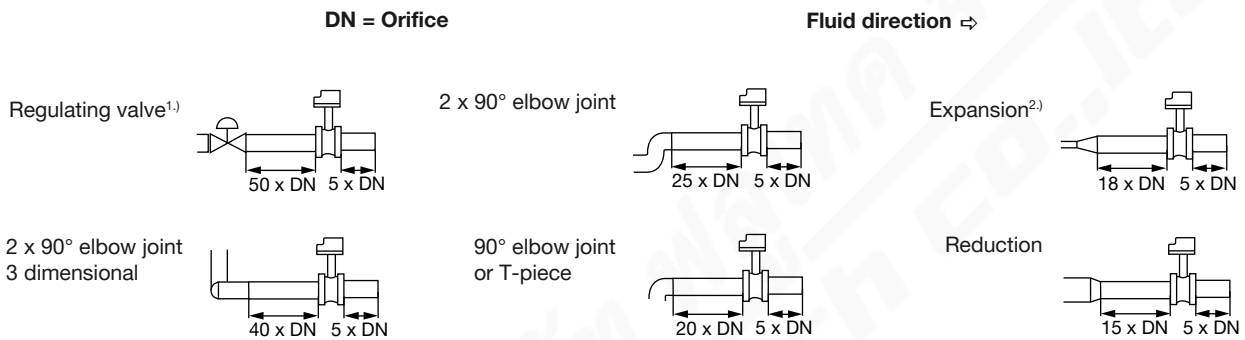

1.) If the valve cannot be mounted after the measuring device, the minimal distances have to be respected.
 2.) If an expansion cannot be avoided, the minimal distances have to be respected.
 Please note minimum flow velocity

The device can be installed in either horizontal or vertical pipes, but following additional conditions should be respected:

- The pipe always has to be filled with fluid at all times near the device.
- The pipe design must be such that no air bubbles or cavitation can form within the medium near the device at any time.

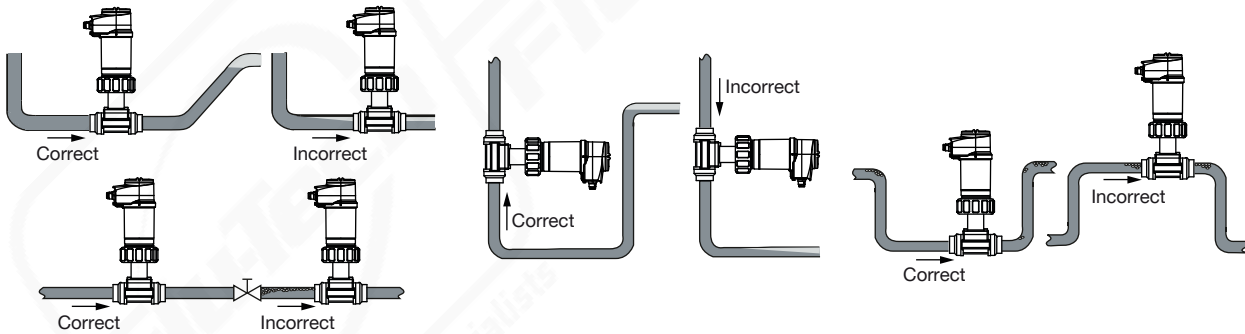

Pressure and temperature ratings must be respected according to the selected fitting material. The suitable pipe size is selected using the diagram in the chapter "Nominal size selection" of the **data sheet Type S020**.

DTS 1000128706 EN Version: Q Status: RL (released | freigegeben | validé) printed: 11.12.2023

7. Product operation

7.1. Measuring principle

When liquid flows through the pipe, the paddle wheel with 4 inserted magnets is set in rotation, producing a measuring signal in the sensor (Hall sensor). The frequency modulated induced voltage is proportional to the flow velocity of the fluid.

A K factor, specific to each pipe, enables the conversion of this frequency into a flow rate/volume.

This K factor is available in the fittings' operating instructions, see **Type S020** ▶.

The electronic component converts the measured signal into several outputs (according to the device variant) and displays the actual value. Totalizers are used to obtain the volume of fluid passed through the pipe.

The electrical connection is provided via a male connector or via male connector M12 and a female connector M12, depending on variant.

8. Product design and assembly

8.1. Product assembly

Note:

- The device Type 8026 is installed into a Bürkert Insertion fitting Type S020 and fastened with a union nut.
- The Insertion fitting Type S020 ensures simple installation into pipes from DN 20...DN 400, see **data sheet Type S020** ▶ for more information.

The device is equipped with a sensor with a paddle wheel, available in long or short variant (depending on the size of the used fitting). The sensor armature, which cannot be dismantled, is plugged-in and pinned to a housing, which contains the electronics board and a removable display/configuration module.

The device operates without the display/configuration module, but it is required for device configuration (i.e. set or restore parameters, configure information to be displayed, enter access codes...) and also for visualizing continuously the measured and processed data.

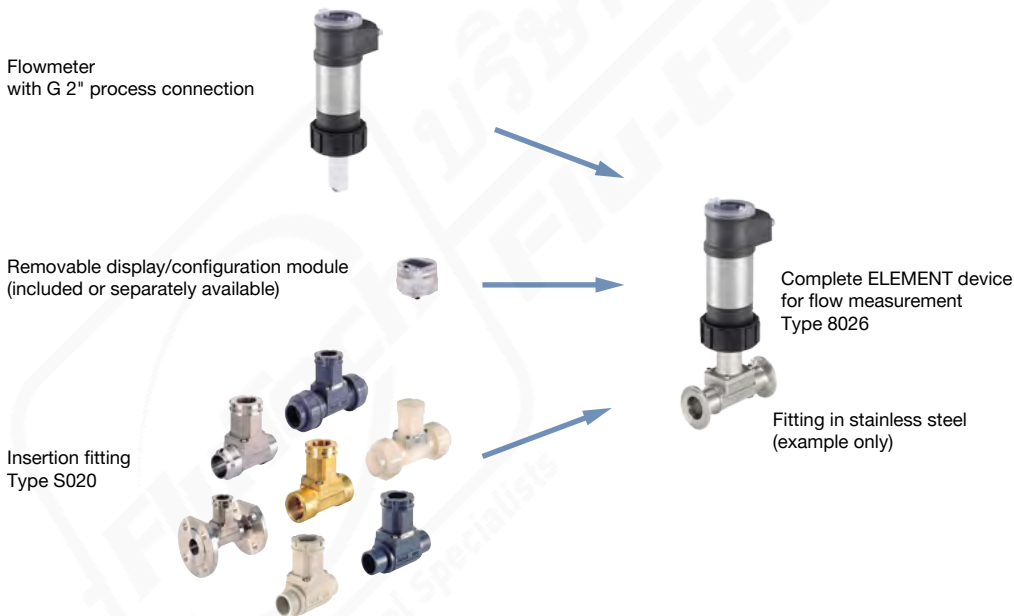

DTS 1000128706 EN Version: Q Status: RL (released | freigegeben | valide) printed: 11.12.2023

9. Networking and combination with other Bürkert products

Example:



| | | | | |
|---|---|--|---|--|
| | | | | |
| Type S020 ▶ Insertion fitting for flow or analysis measurements | Type 8801 ▶ Valve system On/Off ELEMENT | Type 0142 ▶ Diaphragm valve 2/2-way servo-assisted | Type 8611 ▶ eCONTROL - Universal controller | Type 8619 ▶ multiCELL - transmitter/controller |

9.1. Combination of the device with available Type S020 Insertion fittings DN

| Available S020 fittings DN | DN20 | DN50 | DN65 | DN100 | DN200 | DN350 | DN400 |
|----------------------------|--------------|-------------|--------------|-------------|-------------|-------|-------|
| T-Fitting | short sensor | | | | | | |
| Welding socket | | | short sensor | | long sensor | | |
| Fusion spigot | | | short sensor | | long sensor | | |
| Screw-on spigot | | | | long sensor | | | |
| Saddle | | long sensor | | | | | |

10. Ordering information

10.1. Bürkert eShop



Bürkert eShop – Easy ordering and quick delivery

You want to find your desired Bürkert product or spare part quickly and order directly? Our online shop is available for you 24/7. Sign up and enjoy all the benefits.

[Order online now](#)

10.2. Recommendation regarding product selection

Note:

When only ordering devices without a display/configuration module, make sure that you have a display/configuration module at least for parameterising the device. Otherwise you must also order one (see chapter “10.5. Ordering chart accessories” on page 13).

A complete flow measurement equipment consists of a ELEMENT flowmeter Type 8026, a removable display/configuration module and a Bürkert Insertion fitting Type S020.

See **data sheet Type S020** ▶ for more information.

Two or three different components must be ordered in order to select a complete device. The following information is required:

- **Article no.** of the desired flowmeter Type 8026 available with or without display/configuration module (see chapter “10.4. Ordering chart” on page 12)
- **Article no.** of the removable display/configuration module, if necessary (see chapter “10.5. Ordering chart accessories” on page 13)
- **Article no.** of the selected Type S020 Insertion fitting (see **data sheet Type S020** ▶)

10.3. Bürkert product filter



Bürkert product filter – Get quickly to the right product

You want to select products comfortably based on your technical requirements? Use the Bürkert product filter and find suitable articles for your application quickly and easily.

Try out our product filter

10.4. Ordering chart

Note:









- All settings as well as the digital output have to be configured with the display/configuration module (must be ordered separately).
- The following article no.s. have a transparent cover as standard.
- The following is supplied with every device: FKM seal as standard (already mounted), 1 set with a green FKM seal and a black EPDM seal and a mounting instruction sheet.

| Operating voltage | Sensor variant | Output | UL approval | Electrical connection ^{1.)} | Article no. | |
|-------------------|----------------|--|---------------|--|--------------------------------------|-----------------------------------|
| | | | | | Without display/configuration module | With display/configuration module |
| 14...36 V DC | Short | 2 outputs: 1 x transistor NPN + 1 x 4...20 mA (2 wires) | – | 5-pin M12 male connector | 560860 | 561860 |
| | | | UL Recognized | | 560863 | 561863 |
| | | | – | | 560870 | 561870 |
| | | | UL Recognized | | 560873 | 561873 |
| | Long | 3 outputs: 2 x transistors NPN/PNP + 1 x 4...20 mA (2 wires) | – | | 560861 | 561861 |
| | | | UL Recognized | | 560864 | 561864 |
| | | | – | | 560871 | 561871 |
| | | | UL Recognized | | 560874 | 561874 |
| 12...36 V DC | Short | 4 outputs: 2 x transistors NPN/PNP + 2 x 4...20 mA (3 wires) | – | 5-pin M12 male and 5-pin M12 female connectors | 560862 | 561862 |
| | | | UL Recognized | | 560865 | 561865 |
| | – | | 560872 | | 561872 | |
| | UL Recognized | | 560875 | | 561875 | |

1.) Must be ordered separately (see chapter “11.5. Ordering chart accessories” on page 10): M12 male/female connectors (only 1 M12 female for the variant with one 4...20 mA output, 1 M12 male and 1 M12 female for the variant with two 4...20 mA outputs of the device)

DTS 1000128706 EN Version: Q Status: RL (released | freigegeben | validé) printed: 11.12.2023

10.5. Ordering chart accessories

| Description | Article no. |
|--|--|
| Spare part | |
| Opaque cover with seal (1 screw cover with EPDM seal + 1 quarter turn closing cover with silicone seal) | 560948  |
| Transparent cover with seal (1 screw cover with EPDM seal + 1 quarter turn closing cover with silicone seal) | 561843  |
| Mounting accessory | |
| Fastening ring (open) for Type S020 Insertion fitting | 619205  |
| PC union nut for Type S020 Insertion fitting | 619204  |
| Electrical connection | |
| M12 female connector with plastic threaded clamping ring, 5-pin, straight, to be wired | 917116  |
| M12 male connector with plastic threaded clamping ring, 5-pin, straight, to be wired | 560946  |
| M12 female connector with moulded cable (shielded), 5-pin, straight, cable length: 2 m | 438680  |
| M12 male connector with moulded cable (shielded), 5-pin, straight, cable length: 2 m | 559177  |
| Configuration accessory | |
| Removable display/configuration module (with instruction sheet) | 559168  |