



Flowmeter for gases

- Thermal mass flow measurement
- Integrated inlet and outlet pipes for flow conditioning
- Pipe sizes up to 2"
- Integrated display
- Standard and heavy duty variant available

Product variants described in the data sheet may differ from the product presentation and description.

Can be combined with

	Type 3280 Electromotive 2-way globe proportional valve	▶
	Type 3285 Electromotive 2-way globe proportional valve	▶
	Type 8611 eCONTROL - Universal controller	▶
	Type 8802 ELEMENT continuous control valve systems - overview	▶

Type description

This flowmeter series measures especially large flow rates and uses the calorimetric measuring principle. A heated sensor element is cooled down by the gas flow. This cooling effect which depends on the flow velocity and the gas characteristics is the measure for the mass flow rate. This kind of mass flow measurement is independent of pressure and temperature. The flowmeter can be used for monitoring air supplies, but also qualifies for measuring other gases after the corresponding calibration.

The display can be rotated by 180°. Moreover, there is a totaliser integrated which counts the gas volume flowing through the pipe. It can be reset by the console. The flowmeter's pressure drop is negligibly low, the measurement works without any moving parts.

In combination with a solenoid control valve or an air operated process control valve, decentralised flow control loops up to DN 50 are possible.

Type 8008 is available in two variants: standard and heavy duty (with a robust aluminium die-cast electronics housing).

In the heavy duty variant, the sensor is encapsulated in stainless steel.

DTS 1000196002 EN Version: P Status: RL (released | freigegeben | valide) printed: 20.06.2024

FLU-TECH CO. LTD.

Email: sales@flutech.co.th **Website:** https://flutech.co.th

Tel: 02-384-6060, 086-369-5871-3 **Fax:** 02-384-5701 **LINE OA:** @flutech.co.th

Address (HQ): 845/3-4, Moo 3, Theparak Rd., T. Theparak, A. Mueang Samut Prakan, Samut Prakan, 10270, Thailand



Table of contents

1. General technical data	3
2. Approvals and conformities	3
2.1. General notes.....	3
2.2. Conformity	3
2.3. Standards.....	3
3. Materials	4
3.1. Bürkert resistApp	4
4. Dimensions	5
4.1. Standard variant with threaded connection.....	5
4.2. Standard variant with flange connection	5
4.3. Heavy duty variant with threaded connection	6
4.4. Heavy duty variant with flange connection.....	6
5. Device / Process connections	7
5.1. Pin assignment for standard variant	7
5.2. Connection details for heavy duty variant	8
6. Product installation	9
6.1. Installation notes	9
7. Product operation	9
7.1. Flow ranges.....	9
8. Ordering information	10
8.1. Bürkert eShop.....	10
8.2. Bürkert product filter.....	10
8.3. Ordering chart standard variant.....	10
8.4. Ordering chart heavy duty variant.....	10
8.5. Ordering chart accessories standard variant.....	11

DTS 1000196002 EN Version: P Status: RL (released | freigegeben | validé) printed: 20.06.2024

1. General technical data

Product properties	
Dimensions	Further information can be found in chapter "4. Dimensions" on page 5.
Materials	
Seal	NBR, FKM (for oxygen)
Body	Standard variant: stainless steel 1.4301/304, heavy duty variant: stainless steel 1.4571/316Ti
Electronics housing	Standard variant: polycarbonate, heavy duty variant: die-cast aluminium ¹⁾
Performance data	
Nominal flow range (Q _N)	Up to 1,100 Nm ³ /h (air) Further information can be found in chapter "7.1. Flow ranges" on page 9.
Maximum operating pressure (overpressure to atmospheric pressure)	Standard variant: 16 bar, optionally up to PN 40 Heavy duty variant: 50 bar
Measuring accuracy ²⁾	± 1.5 % of reading ± 0.3 % FS, related to air and in consideration of the specified inlet and outlet distances
Measuring span	1:50
Electrical data	
Operating voltage	18...36 V DC
Power consumption	5 W
Output signal	4...20 mA
Load	Maximum load: 500 Ω (current output)
Medium data	
Operating medium	Air, nitrogen, oxygen, natural gas, methane, argon, carbon dioxide, biogas (on request), LPG (on request)
Calibration medium	Air
Medium temperature	-30 °C...+80 °C (higher temperatures on request)
Process/Port connection & communication	
Digital communication interface	Modbus RS485/RTU
Port connection	R ¹ / ₂ ", R ³ / ₄ ", R1", R1 ¹ / ₄ ", R1 ¹ / ₂ ", R2" (all connections as external thread) according to DIN EN 10226 (ISO 7 - 1) or flange connections according to DIN EN 1092 - 1 (stainless steel 1.4404/316L) (other connections on request)
Approvals and conformities	
Certificate	Material certificate 3.1 (on request)
Degree of protection	IP65
Environment and installation	
Ambient temperature	-30 °C...+80 °C (higher temperatures on request)

1.) Silicone-free cleaning on request

2.) If the operating medium is different from the calibration medium, the actual measurement accuracy might vary from the indicated value.

2. Approvals and conformities

2.1. General notes

Note:

- The approvals and conformities listed below must be stated when making enquiries. This is the only way to ensure that the product complies with all required specifications.
- Not all available variants can be supplied with the below mentioned approvals or conformities.

2.2. Conformity

In accordance with the Declaration of Conformity, the product is compliant with the EU Directives.

2.3. Standards

The applied standards which are used to demonstrate compliance with the EU Directives are listed in the EU-Type Examination Certificate and/or the EU Declaration of Conformity.

3. Materials

3.1. Bürkert resistApp

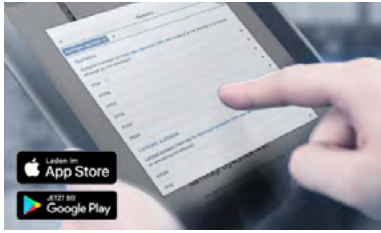

Bürkert resistApp – Chemical Resistance Chart

You want to ensure the reliability and durability of the materials in your individual application case? Verify your combination of media and materials on our website or in our resistApp.

[Start Chemical Resistance Check](#)



4. Dimensions

4.1. Standard variant with threaded connection

Note:

Dimensions in mm, unless otherwise stated

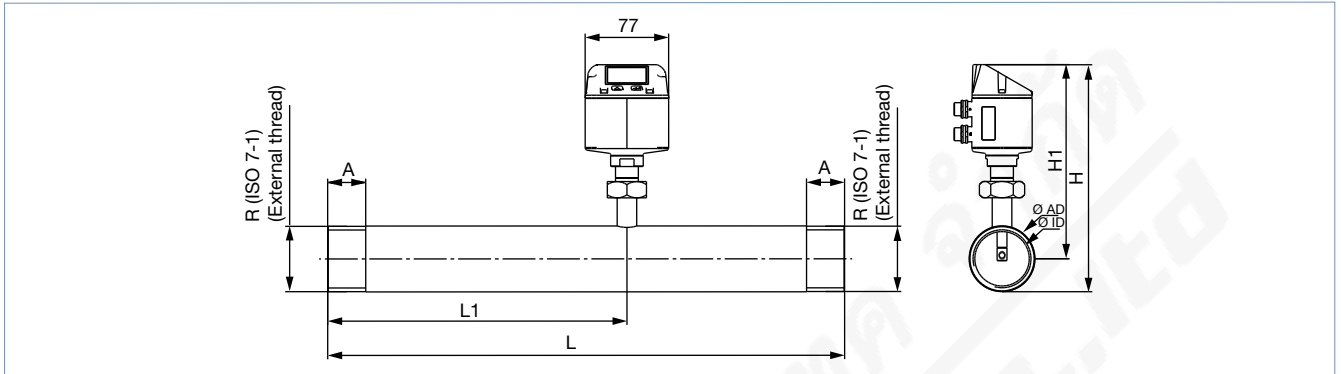

Measuring distance	Ø outer diameter of pipe	Ø inner diameter of pipe	L	L1	H	H1	A	
[inch]	[DN]	[mm]	[mm]	[mm]	[mm]	[mm]	[mm]	
½	15	21.3	16.1	300	210	176.4	165.7	20
¾	20	26.9	21.7	475	275	179.2	165.7	20
1	25	33.7	27.3	475	275	182.6	165.7	25
1¼	32	42.4	36	475	275	186.9	165.7	25
1½	40	48.3	41.9	475	275	186.9	165.7	25
2	50	60.3	53.1	475	275	186.9	165.7	30

4.2. Standard variant with flange connection

Note:

Dimensions in mm, unless otherwise stated

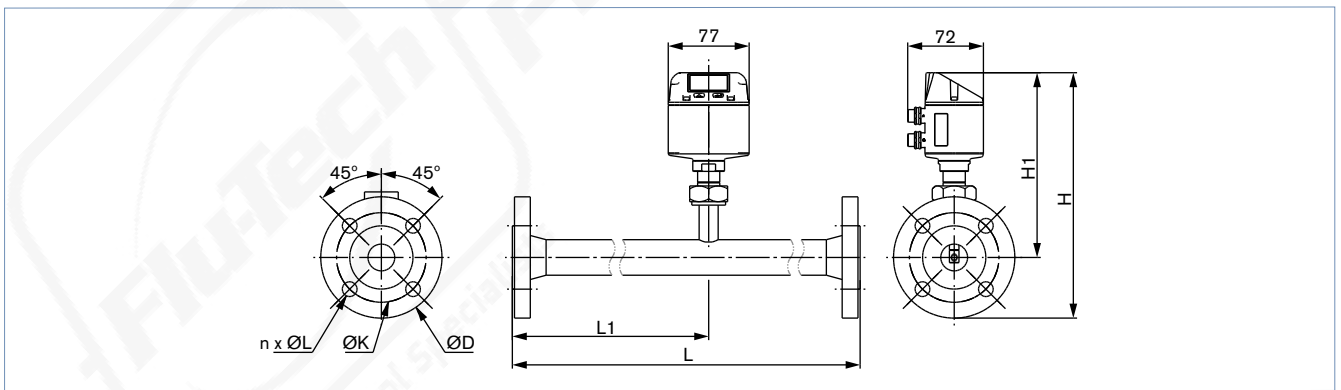

Measuring distance	Ø outer diameter of pipe	Ø inner diameter of pipe	L	L1	H	H1	Ø D	Ø K	n x Ø L	
[inch]	[DN]	[mm]	[mm]	[mm]	[mm]	[mm]	[mm]	[mm]	[mm]	
½	15	21.3	16.1	300	210	213.2	165.7	95	65	4 x 14
¾	20	26.9	21.7	475	275	218.2	165.7	105	75	4 x 14
1	25	33.7	27.3	475	275	223.2	165.7	115	85	4 x 14
1¼	32	42.4	36	475	275	235.7	165.7	140	100	4 x 18
1½	40	48.3	41.9	475	275	240.7	165.7	150	110	4 x 18
2	50	60.3	53.1	475	275	248.2	165.7	165	125	4 x 18
2½	65	76.1	68.9	475	275	268.2	175.7	185	145	8 x 18
3	80	88.9	81.9	475	275	275.7	175.7	200	160	8 x 18

DTS 1000196002 EN Version: P Status: RL (released | freigegeben | valide) printed: 20.06.2024

4.3. Heavy duty variant with threaded connection

Note:

Dimensions in mm, unless otherwise stated

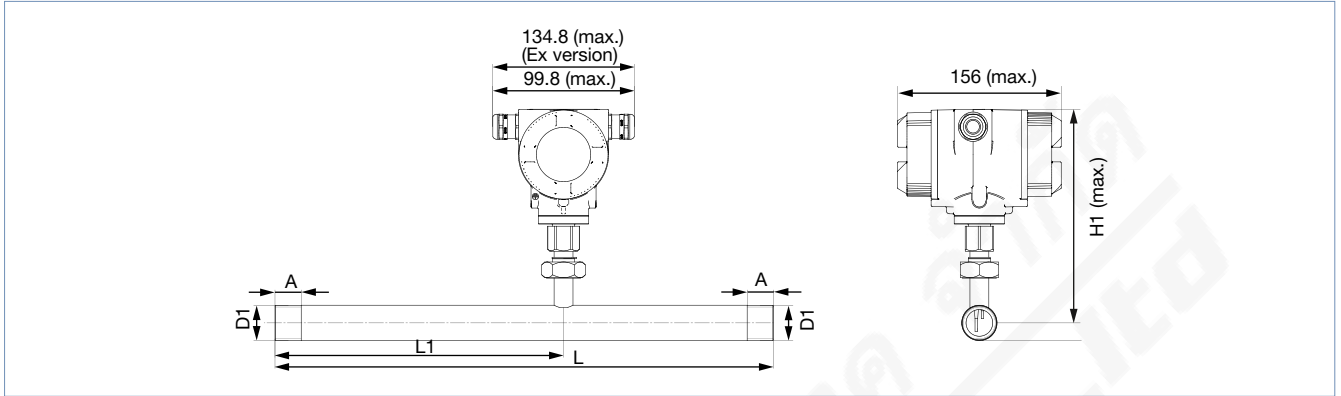

Connection thread	Ø outer diameter of pipe	Ø inner diameter of pipe	L	L1	H	H1	A
[inch]	[mm]	[mm]	[mm]	[mm]	[mm]	[mm]	[mm]
R ½	21.3	16.1	300	210	176.4	165.7	20
R ¾	26.9	21.7	475	275	179.2	165.7	20
R 1	33.7	27.3	475	275	182.6	165.7	25
R 1¼	42.4	36	475	275	186.9	165.7	25
R 1½	48.3	41.9	475	275	186.9	165.7	25
R 2	60.3	53.1	475	275	186.9	165.7	30

4.4. Heavy duty variant with flange connection

Note:

Dimensions in mm

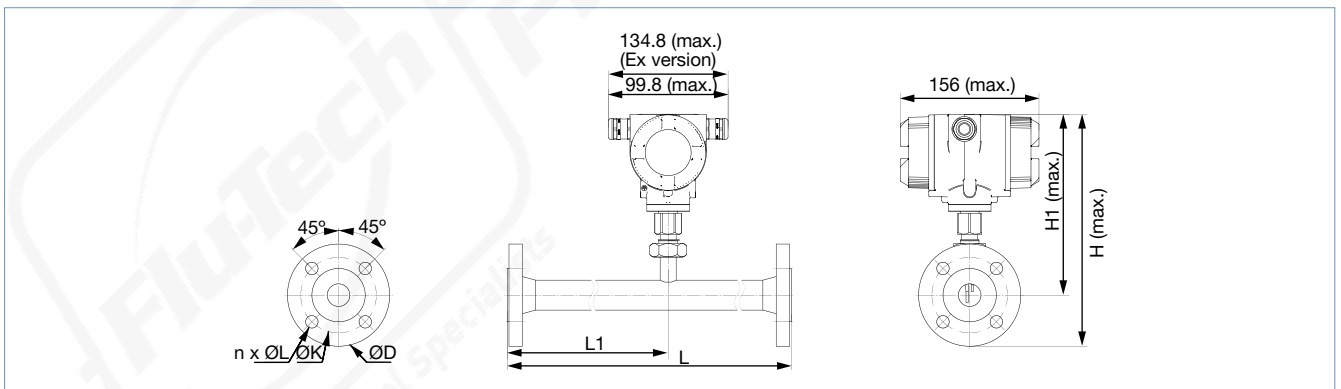

Measuring distance	Ø outer diameter of pipe	Ø inner diameter of pipe	L	L1	H	H1	Flange DIN EN 1092-1		
							Ø D	Ø K	n x Ø L
[DN]	[mm]	[mm]	[mm]	[mm]	[mm]	[mm]	[mm]	[mm]	[mm]
15	21.3	16.1	300	210	213.2	165.7	95	65	4 x 14
20	26.9	21.7	475	275	218.2	165.7	105	75	4 x 14
25	33.7	27.3	475	275	223.2	165.7	115	85	4 x 14
32	42.4	36	475	275	235.7	165.7	140	100	4 x 18
40	48.3	41.9	475	275	240.7	165.7	150	110	4 x 18
50	60.3	53.1	475	275	248.2	165.7	165	125	4 x 18
65	76.1	68.9	475	275	268.2	175.7	185	145	8 x 18
80	88.9	80.9	475	275	275.7	175.7	200	160	8 x 18

DTS 1000196002 EN Version: P Status: RL (released | freigegeben | valide) printed: 20.06.2024

5. Device / Process connections

5.1. Pin assignment for standard variant

Note:

If the sensor is placed at the end of the Modbus system, a termination is required. The sensors have an internal switchable termination. To use the termination, release the 6 fastening screws from the lid and set the internal DIP switch to "On". When reassembling, ensure that the housing seal is correctly seated. Alternatively, a 120R resistor can be installed in the plug between pin 2 and pin 4.

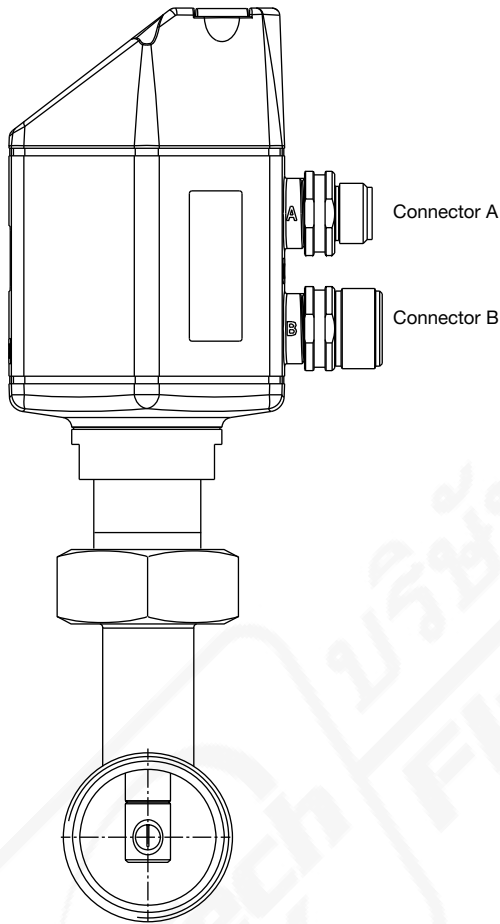

M12 connector

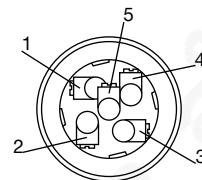

M12 connector A

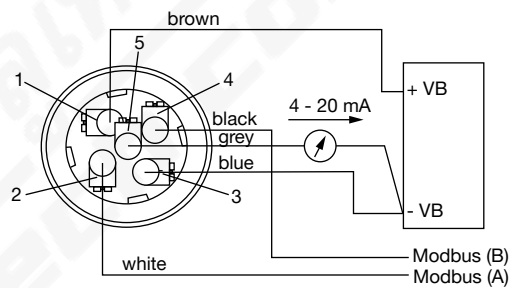

M12 connector B

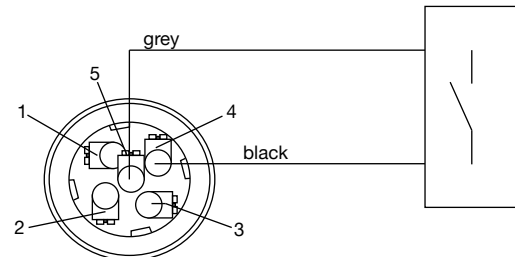

Pin	Connector A (connection port)	Connection cable A	Connector B (pulse port)	Connection cable B
1	VB + Positive voltage supply 12...36 V DC, smoothed	Brown	Not assigned, for internal use only ^{1.)}	Brown
2	RS 485 (A) Modbus-RTU A	White	GND	White
3	VB - Negative voltage supply 12...36 V DC, smoothed	Blue	DIR Direction input	Blue
4	RS 485 (B) Modbus-RTU B	Black	P Pulse for usage	Black
5	I + Current signal 4...20 mA, selected measurement signal	Grey	P Pulse for usage	Grey

1.) Do not connect Pin 1 (connector B) with an electrical potential and/or ground.

5.2. Connection details for heavy duty variant

Note:

If the sensor is used at the end of the Modbus system, a bus termination is required. Connect the enclosed 120R resistor to the terminals, Pin 1 and 3 of X2 connector.

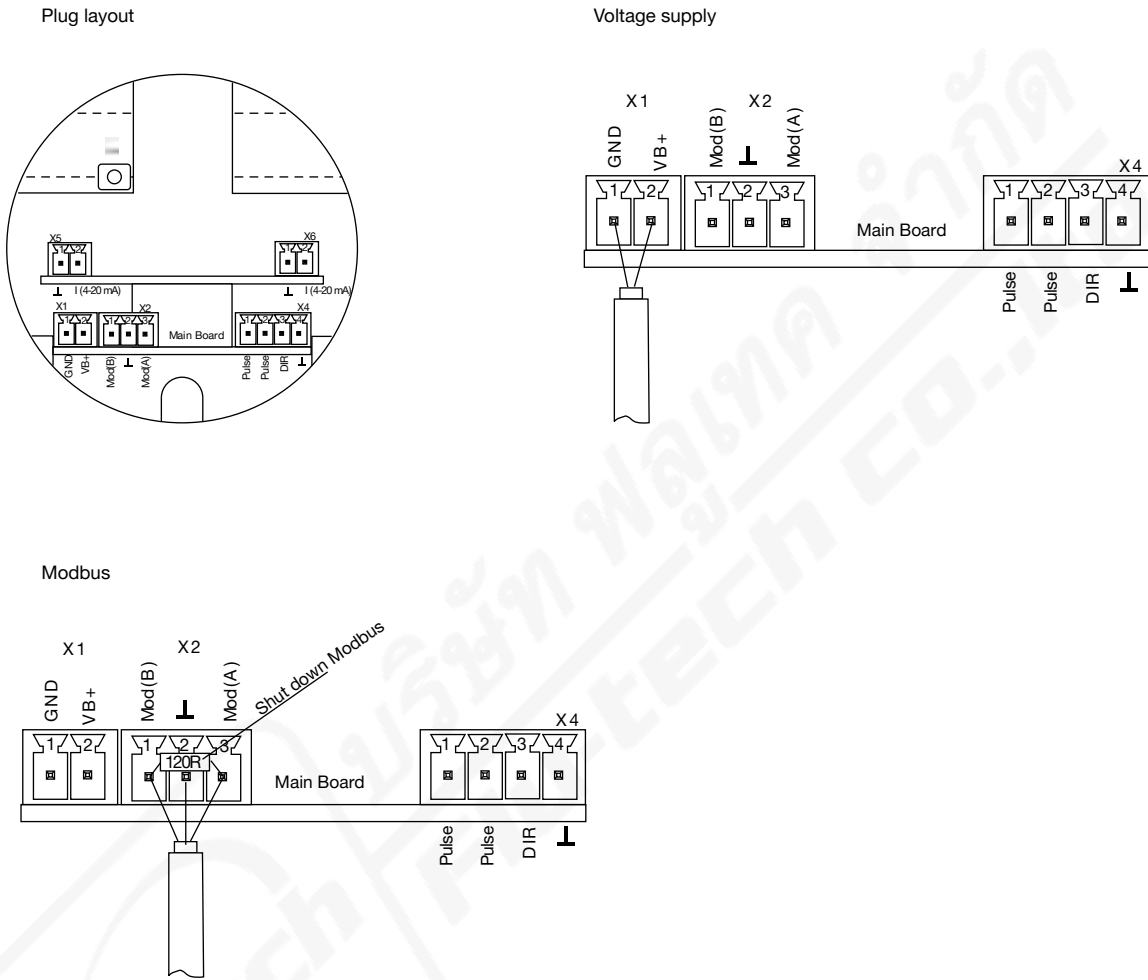

Pin	Plug	Description
1	X1	VB - (negative voltage supply GND)
2	Voltage supply	VB + (positive voltage supply 12...36 V DC)
1	X2	Modbus (B)
2	Modbus	Modbus shield
3		Modbus (A)
1	X4	Pulse/alarm ^{1.)}
2	Direction/impulse	Pulse/alarm ^{1.)}
3		Direction input
4		GND
1	X5	I - Active ^{1.)}
2	Power output 1	I + Active ^{1.)}
1	X6	I - Active ^{1.)}
2	Power output 2	I + Active ^{1.)}

1.) All analogue outputs are galvanically isolated.

6. Product installation

6.1. Installation notes

Note:

The principle of thermal mass flow measurement used here is very sensitive to flow disturbances. It is therefore necessary to observe the recommended inlet and outlet sections.

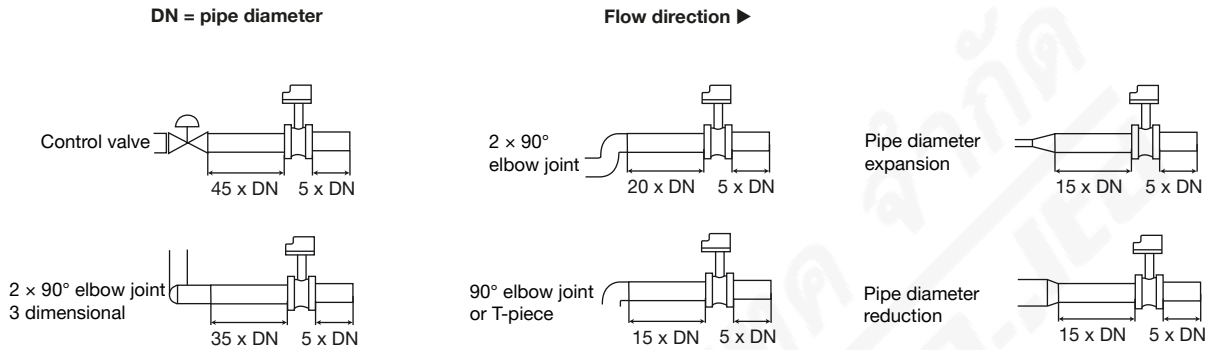

Table of additionally required inlet sections

Flow obstacle in front of the measuring section	Minimum Inlet section (L1)	Minimum Outlet section (L-L1)
Minimum curvature (elbow joint < 90°)	12 x D	5 x D
Pipe diameter reduction (pipe narrows in the direction of the measuring section)	15 x D	5 x D
Pipe diameter expansion (pipe expands in the direction of the measuring section)	15 x D	5 x D
90° elbow joint or T-piece	15 x D	5 x D
2 x 90° elbow joint on one level	20 x D	5 x D
2 x 90° elbow joint (3-dimensional change of direction)	35 x D	5 x D
Control valve	45 x D	5 x D

7. Product operation

7.1. Flow ranges

Note:

The table below lists the final flow rate value for flow velocities up to 185 m/s. Lower or higher maximum flow ranges relative to the pipe diameter can be achieved by adjusting the maximum flow velocity during calibration. The optimal design of the devices is done automatically when ordering.

Operating medium	Pipe diameter							
	½"	¾"	1"	1¼"	1½"	2"	2½"	3"
	[m³/h]	[m³/h]	[m³/h]	[m³/h]	[m³/h]	[m³/h]	[m³/h]	[m³/h]
Reference according to DIN 1945/ISO 1217: 20 °C and 1000 mbar								
Air	90	170	290	530	730	1195	2050	2840
Reference according to DIN 1343: 0 °C and 1013.25 mbar								
Air	80	160	270	490	670	1100	1885	2610
Argon (Ar)	140	275	460	830	1140	1870	3205	4440
Carbon dioxide (CO ₂)	90	175	290	525	720	1185	2030	2810
Nitrogen (N ₂)	80	160	270	485	670	1100	1885	2610
Oxygen (O ₂)	85	165	280	505	695	1140	1955	2710
Laughing gas (N ₂ O)	85	170	285	520	715	1170	2010	2785
Natural gas, methane	50	105	170	310	430	705	1210	1680

DTS 1000196002 EN Version: P Status: RL (released | freigegeben | validé) printed: 20.06.2024

8. Ordering information

8.1. Bürkert eShop



Bürkert eShop – Easy ordering and quick delivery

You want to find your desired Bürkert product or spare part quickly and order directly? Our online shop is available for you 24/7. Sign up and enjoy all the benefits.

[Order online now](#)

8.2. Bürkert product filter

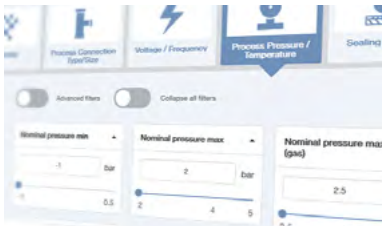

Bürkert product filter – Get quickly to the right product

You want to select products comfortably based on your technical requirements? Use the Bürkert product filter and find suitable articles for your application quickly and easily.

[Try out our product filter](#)

8.3. Ordering chart standard variant

Note:

- Air with operating pressure at 6 bar
- Index N: standard condition, flow rate at 0 °C and 1.013 bar abs
- The total length of the device is not enough to condition the flow, see “6.1. Installation notes” on page 9.
- Calibration for another flow range, other gases and/or operating pressure are available on request.
- The article numbers refer to variants with external threaded connection, article numbers for flange variants are available on request.

Pipe connection [inch]	Inner diameter of pipe [mm]	Max. flow range [Nm ³ /h]	Overall length [mm]	Article no.
R ½	16.1	80	300	773501
R ¾	21.7	160	475	773502
R 1	27.3	270	475	773503
R 1¼	36	485	475	773504
R 1½	41.8	670	475	773505
R 2	53.1	1100	475	773506



8.4. Ordering chart heavy duty variant

Note:

- Air with operating pressure at 6 bar
- Index N: standard condition, flow rate at 0 °C and 1.013 bar abs
- Calibration for another flow range, other gases and/or operating pressure are available on request.

Pipe connection [inch]	Inner diameter of pipe [mm]	Max. flow range [Nm ³ /h]	Overall length [mm]	Article no.
R ½	16.1	80	300	773511
R ¾	21.7	160	475	773512
R 1	27.3	270	475	773513
R 1¼	36	485	475	773514







DTS 1000196002 EN Version: P Status: RL (released | freigegeben | valide) printed: 20.06.2024

Pipe connection [inch]	Inner diameter of pipe [mm]	Max. flow range [Nm ³ /h]	Overall length [mm]	Article no.
R 1½	41.8	670	475	773515 
R 2	53.1	1100	475	773516 

8.5. Ordering chart accessories standard variant

Note:

Without ordering cables, the flow meter is delivered with an M12 connector for port A.

Description	Article no.
5 m cable, assembled on one side with M12 socket, 5-pin	770217 
10 m cable, assembled on one side with M12 socket, 5-pin	770795 
Power supply unit Phoenix Class2 (Type 1573), 85...240 V AC/24 V DC, 1.25 A, NEC Class 2 (UL 1310)	772438 
Power supply unit for standard rail (Type 1573), 100...240 V AC/24 V DC, 1 A, NEC Class 2 (UL 1310)	772361 
Power supply unit for standard rail (Type 1573), 100...240 V AC/24 V DC, 2 A, NEC Class 2 (UL 1310)	772362 
Power supply unit for standard rail (Type 1573), 100...240 V AC/24 V DC, 3.8 A, NEC Class 2 (UL60950 - 1)	772898 
Service software for Type 8008	773890 