





## 2/2 or 3/2-way Whisper Valve with media separation

- Highest chemical resistance
- Compact design with 8.9 mm installation width
- DN 0.8 mm (vacuum up to 5 bar) and 1.2 mm (vacuum up to 3 bar)
- Very fast, almost silent switching with <20 dB (A) and very low power consumption
- High back-pressure tightness, excellent cleanability and 100 % duty cycle

Product variants described in the data sheet may differ from the product presentation and description.

### Can be combined with

- 

**Type 2503** ▶  
Cable plug for whisper valve Types 6712 and 6724
- 

**Type 8763** ▶  
Pressure controller for precise time-pressure dosing

### Type description

Many fluidic processes moving closer to where they are actually required. In the field of medical devices, for example, treatments such as dialysis can be provided to patients in convenient surroundings at home. Washing units in analytical equipment are positioned on the pipetting arm or directly on the print head in printing applications. This imposes different requirements on the components used. Solenoid valves must be able to switch without being heard. They need to be smaller and lighter to be used in mobile devices. However, their ability to achieve a long service life and excellent switching characteristics is every bit as important. The Whisper Valve Type 6724 combines all of these traits and, thanks to its modular structure and range of available material variants, this valve is universally applicable.



**Table of contents**

<b>1. General technical data</b>	<b>3</b>
1.1. General data.....	3
1.2. Medium pressure .....	4
<b>2. Product versions</b>	<b>5</b>
<b>3. Circuit functions</b>	<b>5</b>
<b>4. Approvals and conformities</b>	<b>6</b>
4.1. General notes.....	6
4.2. Conformity .....	6
4.3. Standards.....	6
4.4. Foods and beverages/Hygiene .....	6
<b>5. Materials</b>	<b>6</b>
5.1. Bürkert resistApp .....	6
5.2. Material specifications .....	6
<b>6. Dimensions</b>	<b>7</b>
6.1. Bürkert sub-base (9 x 26).....	7
6.2. Flange pattern (Bürkert sub-base 9 x 26) .....	8
6.3. Bürkert sub-base (26 x 57) horizontal.....	9
6.4. Flange pattern (Bürkert sub-base 26 x 57) .....	9
6.5. Threaded port version (UNF ¼" -28) .....	10
6.6. Tube connector version.....	11
<b>7. Device/Process connections</b>	<b>11</b>
7.1. Pin assignment .....	11
<b>8. Ordering information</b>	<b>12</b>
8.1. Bürkert eShop.....	12
8.2. Bürkert product filter .....	12
8.3. Ordering chart.....	12
Standard version.....	12
Impulse version.....	13
8.4. Ordering chart accessories.....	14
Manifolds .....	14
Cable plug Type 2503 .....	14
Fittings and hoses.....	14

DTS 1000262565 EN Version: T Status: RL (released | freigegeben | valide) printed: 24.04.2024

## 1. General technical data

### 1.1. General data

Product properties	
Dimensions	Further information can be found in chapter "6. Dimensions" on page 7.
Material	
Seal	FFKM, EPDM, FKM or FFKM HCR (High Chemical Resistance)
Fluidic housing	PEEK, PPS, (PVDF on request)
Internal volume	Bürkert sub-base (9 x 26): approx. 38 µl Bürkert sub-base (26 x 57) horizontal: approx. 93 µl Threaded version UNF ¼"-28: approx. 59 µl Tube connector: approx. 68 µl
Orifice	
Standard version	DN 0.8 or DN 1.2
Impulse version	DN 1.2
FFKM HCR version	DN 1.2
Circuit function	Further information can be found in chapter "3. Circuit functions" on page 5.
Typical product service life	10 million switching cycles (acc. to laboratory duration tests) <sup>1)</sup>
Performance data	
Pressure range	Further information can be found in chapter "1.2. Medium pressure" on page 4.
Duty cycle <sup>4)</sup>	100 % continuous operation
Switching noise	30 dB (A) (<20 dB (A) on request <sup>2)</sup> )
Switching time <sup>3)</sup>	Opening: approx. 3 ms (Pressure build-up 0...10%) Closing: approx. 3 ms (Pressure reduction 100...90%)
Electrical data	
Operating voltage	12 V/DC, 24 V/DC (other voltages on request)
Nominal power	
Standard version	1.25 W <sup>5)</sup>
Impulse version	1.25 W <sup>5)</sup> (impulse length min. 500 ms)
Voltage tolerance	
Standard version	-10 %/+5 % (including residual ripple)
Impulse version	±5 % (including residual ripple)
FFKM HCR version	-10 %/+5 % (including residual ripple)
Medium data	
Operating medium	Resistant to neutral and aggressive gases and liquids. Further information can be found in chapter "5.1. Bürkert resistApp" on page 6.
Medium temperature	
Standard version	FFKM: +15 °C...+50 °C (59 °F...122 °F) FKM: 0 °C...+50 °C (32 °F...122 °F) EPDM: 0 °C...+50 °C (32 °F...122 °F)
Impulse version	FFKM: +15 °C...+40 °C (59 °F...104 °F) FKM: 0 °C...+40 °C (32 °F...104 °F) EPDM: 0 °C...+40 °C (32 °F...104 °F) (Higher temperature range on request)
FFKM HCR version	FFKM HCR: +15 °C...+50 °C (59 °F...122 °F) <sup>6)</sup>
Viscosity	Max. 21 mm <sup>2</sup> /s
Process/Port connection & communication	
Electrical connection <sup>7)</sup>	Plug with detent, pin spacing 2 mm, see data sheet <b>Type 2503</b> ▶
Port connection	Bürkert sub-base (9 x 26) Bürkert sub-base (26 x 57) horizontal Threaded version UNF ¼"-28 Tube connector version
Approvals and conformities	
Degree of protection	IP10
Foods and beverages/Hygiene	Further information can be found in chapter "4.4. Foods and beverages/Hygiene" on page 6.

**Environment and installation**

Installation position	As required, preferably with actuator upright
<b>Ambient temperature</b>	
FFKM	+ 15 °C...+50 °C (59 °F...122 °F)
FKM	0 °C...+50 °C (32 °F...122 °F)
EPDM	0 °C...+50 °C (32 °F...122 °F)
FFKM HCR	+ 15 °C...+50 °C (59 °F...122 °F)

- 1.) The service life depends on the medium, temperature, pressure, sealing material and individual operating conditions.
- 2.) The maximum body temperature must not exceed +110 °C. In continuous operation, care must be taken to ensure sufficient heat dissipation (convection) on the metal surface of the valve. Overheating of the valve can lead to damage.
- 3.) May be higher with impulse version. < 20 dB(A) with optional soft-close electronics only possible in conjunction with standard valve.
- 4.) Measurement at +20 °C, 2 bar at the valve outlet acc. to DIN ISO 12238:2001
- 5.) No further power reduction possible
- 6.) Reduced shifting performance at 15 °C
- 7.) Please order socket with flying leads separately (see "8.4. Ordering chart accessories" on page 14).  
 Other suitable connectors are, for example W+P: Series 521 (socket 521S-02-1; contact 521S-01-2-00) or JST (socket PHR-2; contact SPH-002GW-P0.5S), version 04/2015). As a PCB connector we recommend a pin size of 0.5 x 0.5 mm, grid size 2 mm and a maximum size of the connector of 4.9 x 2.5 mm. E.g. Samtec SQT-102-01-x-S (x=L or F) or W+P Series 257 Part No. 257-002-1-50-00-6.

**1.2. Medium pressure**

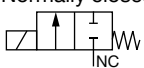
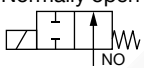
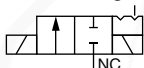
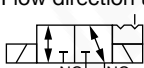
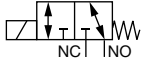
Circuit function	Orifice [mm]	Pressure range at the connection			Max. differential pressure [bar]
		NC [bar]	COM [bar]	NO [bar]	
<b>CF A</b> 2/2-way solenoid valve Direct-acting Normally closed 	0.8	Vac...5 <sup>1,2)</sup>	N/A	– <sup>2)3)</sup>	5
	1.2	Vac...3 <sup>1)</sup>	N/A	– <sup>2)3)</sup>	3
	1.2 (with boost electronics <sup>4)</sup> )	Vac...7 <sup>1)</sup>	N/A	– <sup>2)3)</sup>	7
	1.2 (with seal material FFKM HCR)	Vac...2 <sup>1)</sup>	N/A	– <sup>2)3)</sup>	2
<b>CF B</b> 2/2-way solenoid valve Direct-acting Normally open 	0.8	0...3 <sup>1)3)</sup>	N/A	Vac...5	5
	1.2	– <sup>1)2)3)</sup>	N/A	Vac...2	2
<b>CF P</b> 2/2-way impulse solenoid valve Direct-acting 	1.2	Vac...2 <sup>1)</sup>	N/A	– <sup>2)3)</sup>	2
<b>CF S</b> 3/2-way impulse solenoid valve Direct-acting Flow direction unrestricted 	1.2	Vac...2 <sup>1)</sup>	0...2 <sup>3)</sup>	Vac...2 <sup>1)</sup>	2
<b>CF T</b> 3/2-way solenoid valve Direct-acting Flow direction optional Universal 	0.8	Vac...5 <sup>1)</sup>	0...3 <sup>3)</sup>	Vac...5 <sup>1)</sup>	5
	1.2	Vac...3 <sup>1)</sup>	0...3 <sup>3)</sup>	Vac...3 <sup>1)</sup>	3
	1.2 (with boost electronics <sup>4)</sup> )	Vac...7 <sup>1)</sup>	0...5 <sup>3)</sup>	Vac...2 <sup>1)</sup>	7
	1.2 (with seal material FFKM HCR)	Vac...2 <sup>1)</sup>	0...2 <sup>3)</sup>	Vac...2 <sup>1)</sup>	2

- 1.) Connect technical vacuum (-0.8 bar) to NC or NO. If vacuum is connected to (COM/OUT), significantly reduced flow must be expected.
- 2.) Up to 2 bar, the flow direction is permissible even against the specification.
- 3.) Low vacuum due to back pressure at media flow permissible. In case of continuous operation with higher vacuum, there is a risk of flow reduction. In case of doubt, please contact your Bürkert sales office.
- 4.) For information on the optional boost electronics see chapter "8.4. Ordering chart accessories" on page 14.

DTS 1000262565 EN Version: T Status: RL (released | freigegeben | valide) printed: 24.04.2024

## 2. Product versions

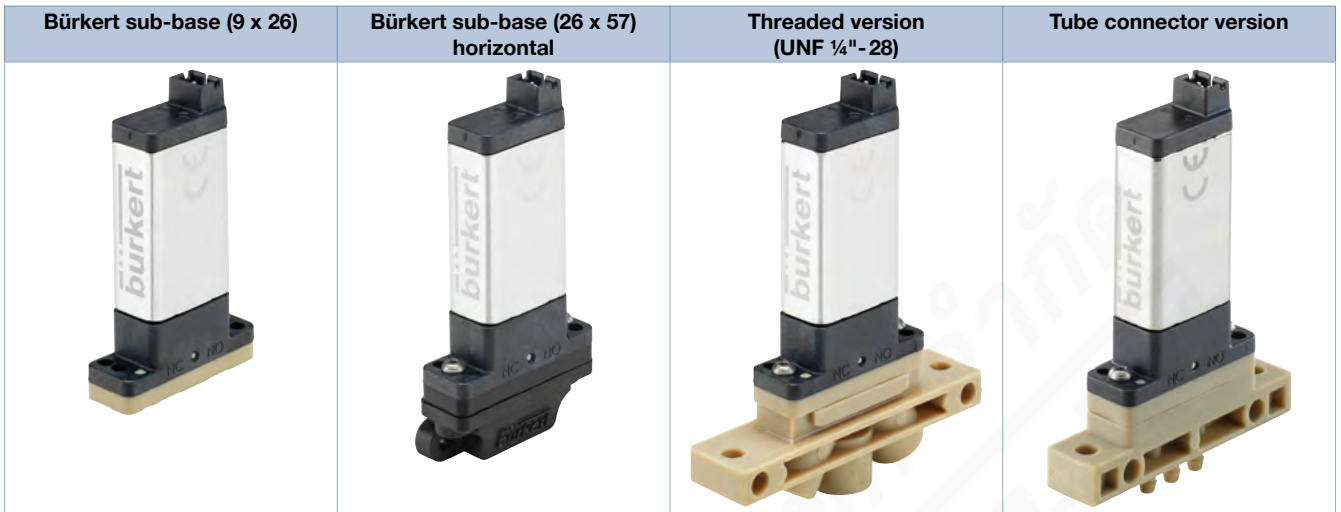

## 3. Circuit functions

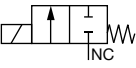
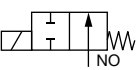
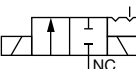
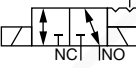
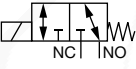
Symbol	Description
	<b>Circuit function A (CF A)</b> 2/2-way solenoid valve Direct-acting Normally closed
	<b>Circuit function B (CF B)</b> 2/2-way solenoid valve Direct-acting Normally open
	<b>Circuit function P (CF P)</b> 2/2-way impulse solenoid valve Direct-acting
	<b>Circuit function S (CF S)</b> 3/2-way impulse solenoid valve Direct-acting Flow direction unrestricted
	<b>Circuit function T (CF T)</b> 3/2-way solenoid valve Direct-acting Flow direction optional Universal

DTS 1000262565 EN Version: T Status: RL (released | freigegeben | validé) printed: 24.04.2024

## 4. Approvals and conformities

### 4.1. General notes

- The approvals and conformities listed below must be stated when making enquiries. This is the only way to ensure that the product complies with all required specifications.
- Not all available versions can be supplied with the below mentioned approvals or conformities.

### 4.2. Conformity

In accordance with the Declaration of Conformity, the product is compliant with the EU Directives.

### 4.3. Standards

The applied standards which are used to demonstrate compliance with the EU Directives are listed in the EU-Type Examination Certificate and/or the EU Declaration of Conformity.

### 4.4. Foods and beverages/Hygiene

Conformity	Description
FDA	<b>FDA – Code of Federal Regulations (valid for the variable code PL03)</b> All wetted materials are compliant with the Code of Federal Regulations published by the FDA (Food and Drug Administration, USA) according to the manufacturer’s declaration.

## 5. Materials

### 5.1. Bürkert resistApp

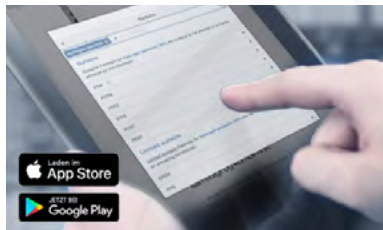

#### Bürkert resistApp – Chemical resistance chart

You want to ensure the reliability and durability of the materials in your individual application case? Verify your combination of media and materials on our website or in our resistApp.

[Start chemical resistance check](#)

### 5.2. Material specifications

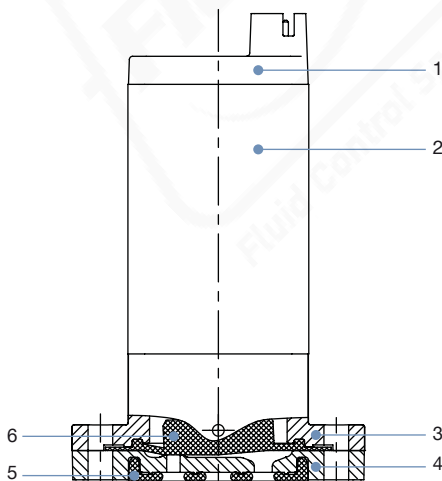

No.	Element	Material
1	Cover	LCP
2	Coil housing	nickel-plated
3	Valve housing	PPS
4	Fluidic housing <sup>1.)</sup>	PEEK or PPS (PVDF on request)
5	Sub-base seal <sup>1.)</sup>	FFKM, EPDM or FKM
6	Diaphragm <sup>1.)</sup>	FFKM, EPDM, FKM or FFKM HCR (High Chemical Resistance)

1.) in contact with medium

## 6. Dimensions

### 6.1. Bürkert sub-base (9 x 26)

**Note:**

- Dimensions in mm
- Including fastening screws M2 x 10

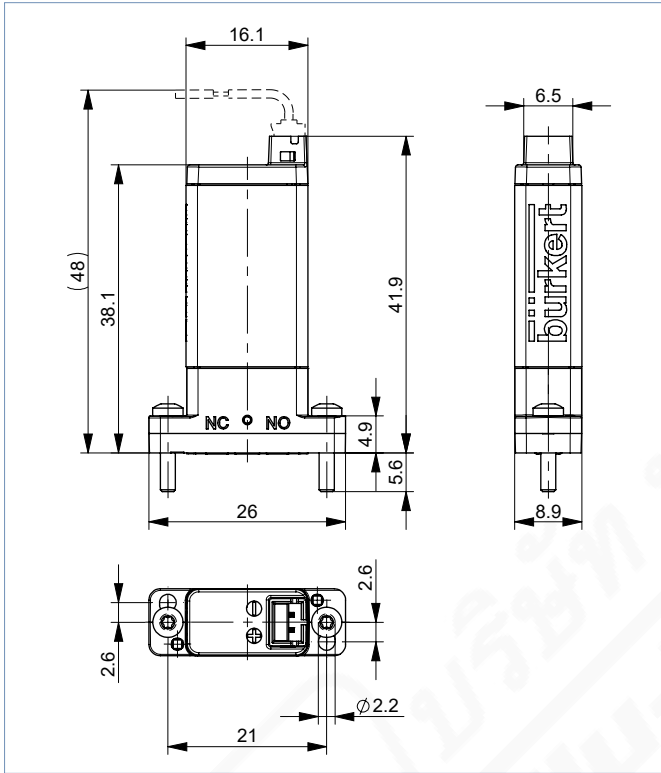

6.2. Flange pattern (Bürkert sub-base 9 x 26)

Note:  
Dimensions in mm

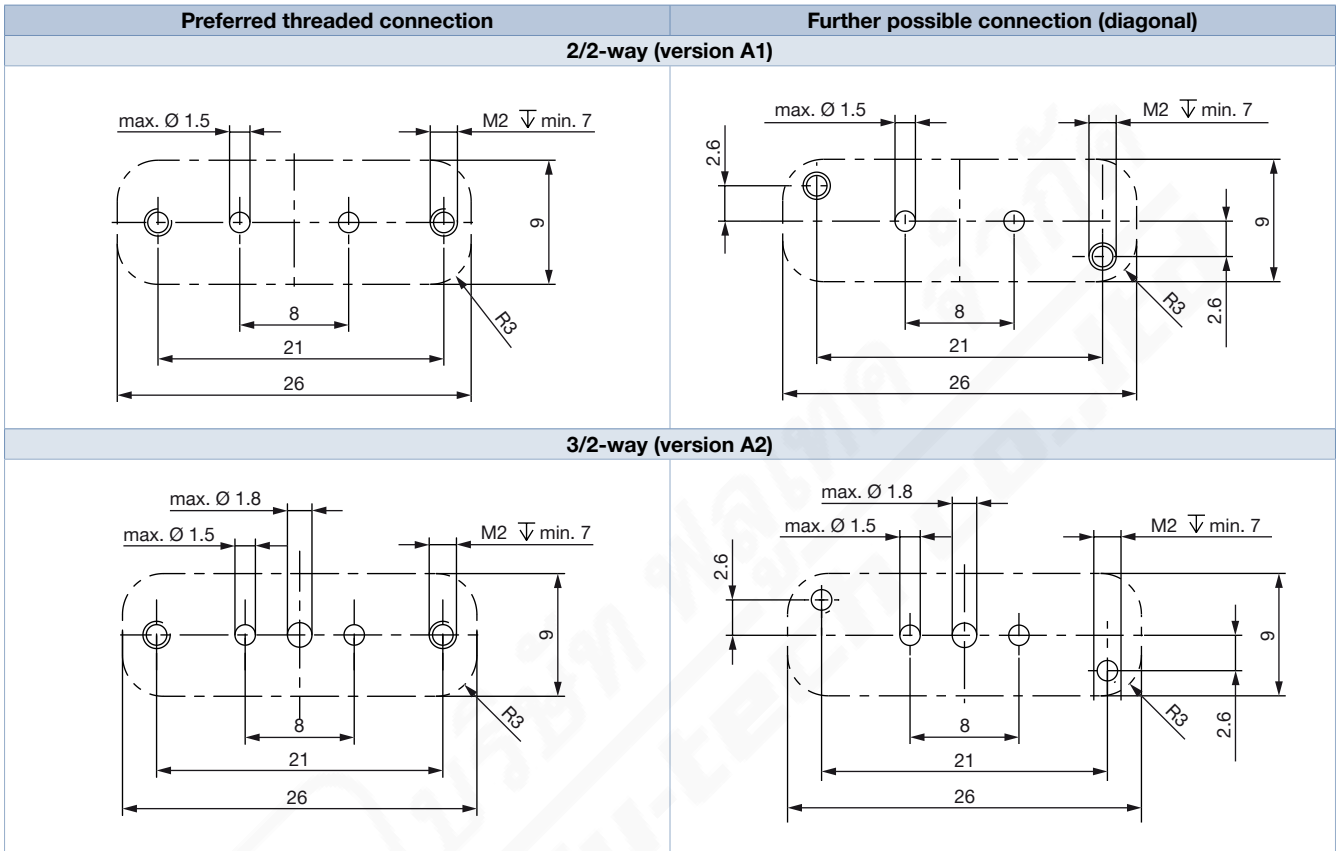

DTS 1000262565 EN Version: T Status: RL (released | freigegeben | valide) printed: 24.04.2024

### 6.3. Bürkert sub-base (26 x 57) horizontal

**Note:**

- Dimensions in mm
- Optional: Sub-base can be turned by 180°
- Including fastening screws M2 x 6

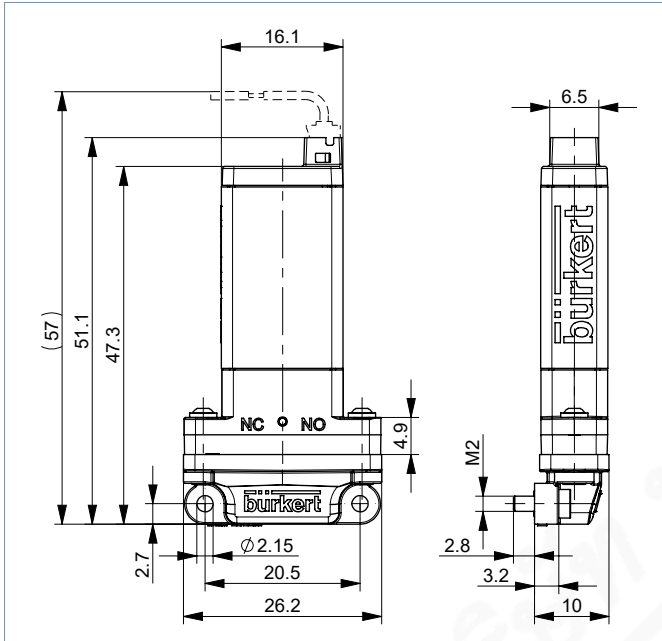

### 6.4. Flange pattern (Bürkert sub-base 26 x 57)

**Note:**

Dimensions in mm

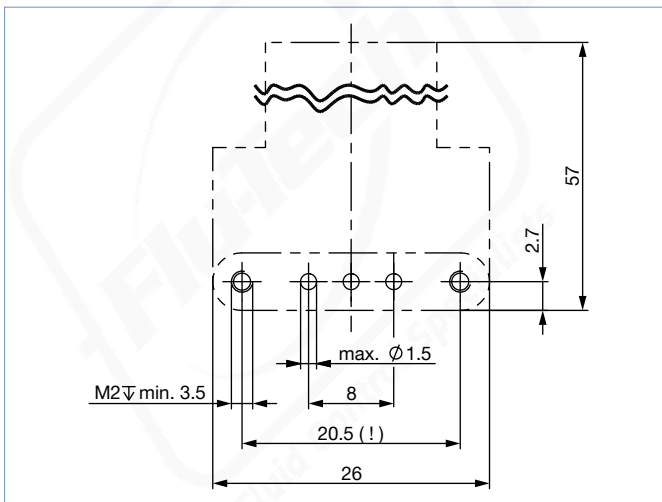

DTS 1000262565 EN Version: T Status: RL (released | freigegeben | validé) printed: 24.04.2024

6.5. Threaded port version (UNF 1/4"-28)

Note:  
Dimensions in mm

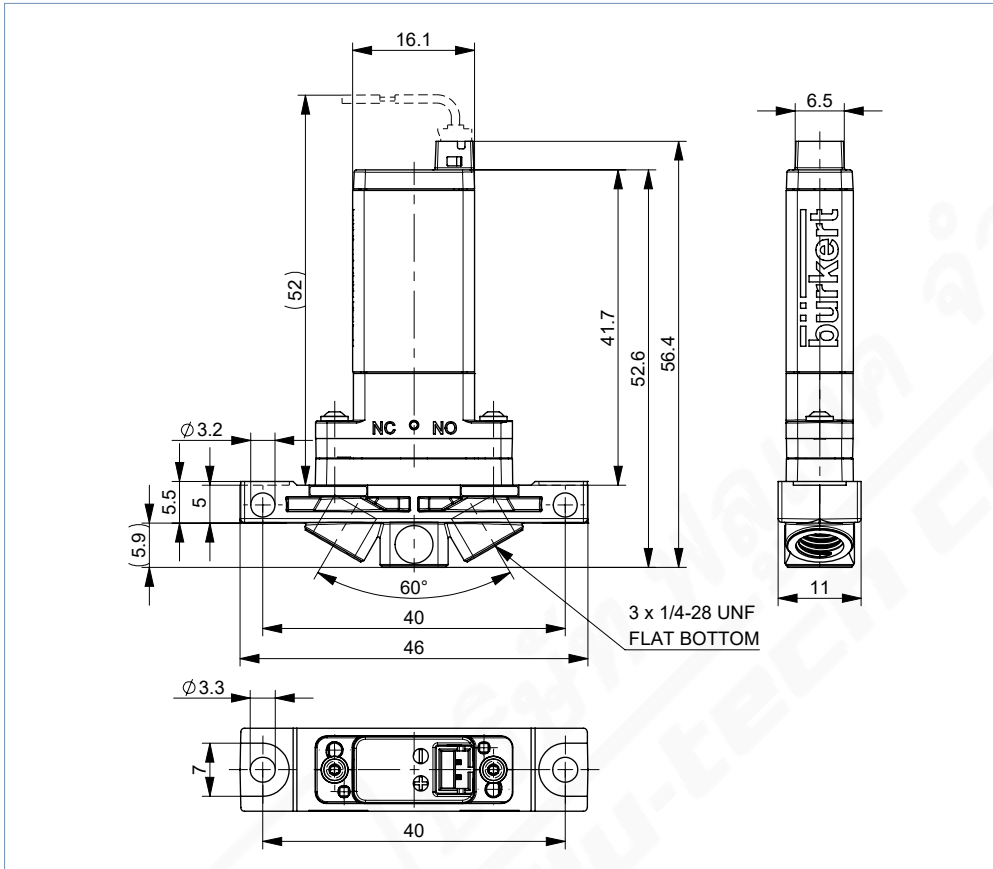

DTS 1000262565 EN Version: T Status: RL (released | freigegeben | validé) printed: 24.04.2024

### 6.6. Tube connector version

**Note:**  
Dimensions in mm

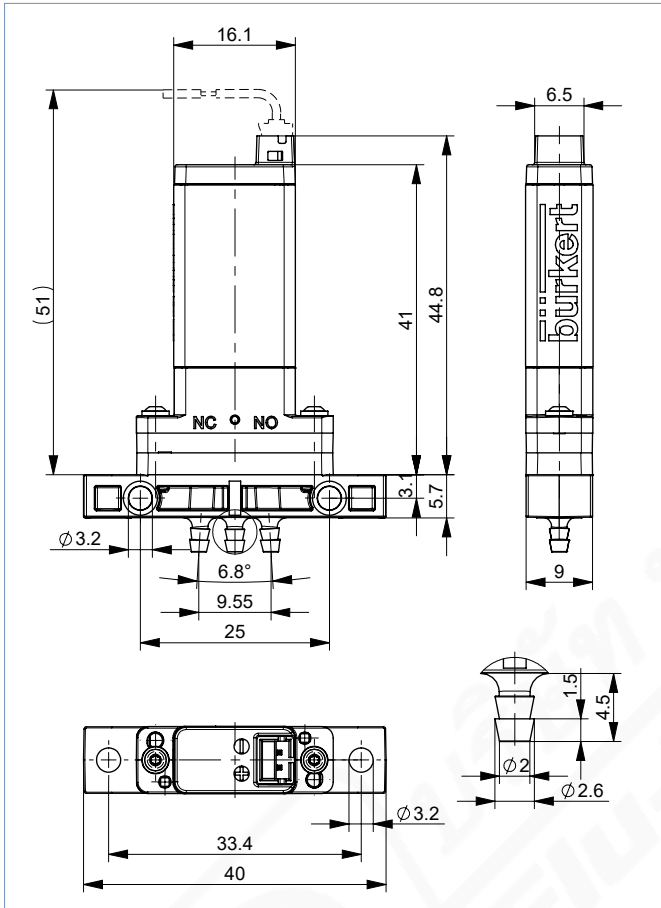

## 7. Device/Process connections

### 7.1. Pin assignment

Electrical control for impulse versions		Impulse 500 ms		
		1	2	
<b>CF P</b> 2/2-way impulse solenoid valve Direct-acting 	NC (open)	-	+	
	NC (closed)	+	-	
<b>CF S</b> 3/2-way impulse solenoid valve Direct-acting Flow direction unrestricted 	NC ⇄ COM (open)	-	+	
	NO ⇄ COM (open)	+	-	

DTS 1000262565 EN Version: T Status: RL (released | freigegeben | valide) printed: 24.04.2024

## 8. Ordering information

### 8.1. Bürkert eShop



**Bürkert eShop – Easy ordering and quick delivery**

You want to find your desired Bürkert product or spare part quickly and order directly? Our online shop is available for you 24/7. Sign up and enjoy all the benefits.

[Order online now](#)

### 8.2. Bürkert product filter

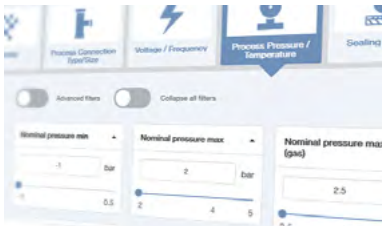

**Bürkert product filter – Get quickly to the right product**

You want to select products comfortably based on your technical requirements? Use the Bürkert product filter and find suitable articles for your application quickly and easily.

[Try out our product filter](#)

### 8.3. Ordering chart

#### Standard version

**Note:**

- Plug connectors with flying leads or electronics Type 2503 are not included in the scope of delivery and must be ordered separately, see [“8.4. Ordering chart accessories” on page 14](#)).
- Including mounting screws for the following port connections:  
Bürkert sub-base (9 x 26): M2 x 10-TORX T6-A2, Bürkert sub-base (26 x 57) horizontal: M2 x 6-TORX T6-A2
- Mounting screws M1.6 x 8-ISK for replacing Type 6604 with Type 6724 are available on request.

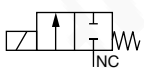
Circuit function	Port connection	Orifice	Q <sub>Nr</sub> value air <sup>2)</sup>	K <sub>v</sub> value water <sup>1)</sup>	C <sub>v</sub> value water	Voltage/frequency	Pressure range <sup>3)</sup>	Max. pressure difference	Body material	Seal material	Article no.	
		[mm]	[l/min]	[m <sup>3</sup> /h]	[gpm]	[V]	[bar]	[bar]				
<b>CF A</b> 2/2-way solenoid valve Direct-acting Normally closed 	Bürkert sub-base (9 x 26)	0.8	10.7	0.01	0.012	24	Vac...5	5	PEEK	FFKM	20034162	
									PPS	FKM	20071070	
										EPDM	20037617	
	UNF 1/4"-28		10.7	0.01	0.012	24	Vac...5	5	PEEK	FFKM	20071068	
	Tube connector		10.7	0.01	0.012	24	Vac...5	5	PEEK	FFKM	20071231	
										EPDM	20071233	
	Bürkert sub-base (26 x 57) horizontal		10.7	0.01	0.012	24	Vac...5	5	PPS	EPDM	20071279	
	Bürkert sub-base (9 x 26)		1.2	28	0.026	0.03	24	Vac...3	3	PEEK	FFKM	20027698
		PPS								FKM	20071048	
										EPDM	20037618	
UNF 1/4"-28			28 <sup>4)</sup>	0.026 <sup>4)</sup>	0.03 <sup>4)</sup>	24	Vac...3	3	PEEK	FFKM	20071047	
						12			FKM	20071065		
Bürkert sub-base (9 x 26)			28	0.026	0.03	24	Vac...2	2	PEEK	FFKM HCR	20048280	
UNF 1/4"-28			28 <sup>4)</sup>	0.026 <sup>4)</sup>	0.03 <sup>4)</sup>	24	Vac...2	2	PEEK	FFKM HCR	20075595	

DTS 1000262565 EN Version: T Status: RL (released | freigegeben | validé) printed: 24.04.2024

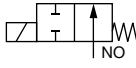
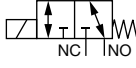
Circuit function	Port connection	Orifice	Q <sub>Nn</sub> value air <sup>2.)</sup>	K <sub>v</sub> value water <sup>1.)</sup>	C <sub>v</sub> value water	Voltage/frequency	Pressure range <sup>3.)</sup>	Max. pressure difference	Body material	Seal material	Article no.
		[mm]	[l/min]	[m <sup>3</sup> /h]	[gpm]	[V]	[bar]	[bar]			
<b>CF B</b> 2/2-way solenoid valve Direct-acting Normally open 	Bürkert sub-base (9 x 26)	1.2	28	0.026	0.03	24	Vac...2	2	PEEK	FFKM	20071046
		1.2	28	0.026	0.03	12	Vac...3	3	PEEK	FFKM	20027694
<b>CF T</b> 3/2-way solenoid valve Direct-acting Flow direction optional Universal 	Bürkert sub-base (9 x 26)	0.8	10.7	0.01	0.012	24	0...3 <sup>5.)</sup>	5	PEEK	FFKM	20030343
						12			PPS	FKM	20071074
						24			PPS	EPDM	20071081
	UNF 1/4"-28	10.7	0.01	0.012	0.012	24	0...3 <sup>5.)</sup>	5	PEEK	FFKM	20071072
									PEEK	FFKM	20071230
	Tube connector	10.7	0.01	0.012	0.012	24	0...3 <sup>5.)</sup>	5	PEEK	EPDM	20071234
									PPS	FKM	20071281
	Bürkert sub-base (26 x 57) horizontal	10.7	0.01	0.012	0.012	24	0...3 <sup>5.)</sup>	5	PPS	EPDM	20071280
									PEEK	FFKM	20071063
	Bürkert sub-base (9 x 26)	1.2	28	0.026	0.03	12	Vac...3	3	PEEK	FFKM	20071045
									PPS	FKM	20071049
	UNF 1/4"-28	28 <sup>4.)</sup>	0.026 <sup>4.)</sup>	0.03 <sup>4.)</sup>	0.03 <sup>4.)</sup>	24	Vac...3	3	PEEK	FFKM	20071045
PEEK									FFKM HCR	20075596	
Bürkert sub-base (9 x 26)	28 <sup>4.)</sup>	0.026 <sup>4.)</sup>	0.03 <sup>4.)</sup>	0.03 <sup>4.)</sup>	24	Vac...2	2	PEEK	FFKM HCR	20054962	
								PEEK	FFKM HCR	20054962	

- 1.) Measurement at +20 °C, 1 bar at the valve inlet and free outlet
- 2.) Converted to standard conditions
- 3.) Connect technical vacuum (-0.8 bar) to NC or NO. If vacuum is connected to (COM/OUT), significantly reduced flow must be expected.
- 4.) K<sub>v</sub> value of the valve. The UNF connections have a diameter of 1.2 mm; in conjunction with conventional connection technology (10 cm hose each with ID=1.6 mm), this results in practical values of K<sub>v</sub>=0.015 m<sup>3</sup>/h; C<sub>v</sub>=0.017 gpm; Q<sub>Nn</sub>=21.8 l/min.
- 5.) Applies to pressure connection to COM. For pressure connection to NC or NO Vac...5 bar applies.

**Impulse version**

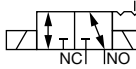
Circuit function	Port connection	Orifice	Q <sub>Nn</sub> value air <sup>2.)</sup>	K <sub>v</sub> value water <sup>1.)</sup>	C <sub>v</sub> value water	Voltage/frequency	Pressure range <sup>3.)4.)</sup>	Max. pressure difference	Body material	Seal material	Article no.
		[mm]	[l/min]	[m <sup>3</sup> /h]	[gpm]	[V]	[bar]	[bar]			
<b>CF P</b> 2/2-way impulse solenoid valve Direct-acting 	Bürkert sub-base (9 x 26)	1.2	25	0.024	0.027	24	Vac...2	2	PPS	FKM	355749
						24			PEEK	FFKM	355744
						12			PEEK	FFKM	355750
	UNF 1/4"-28	25 <sup>5.)</sup>	0.024 <sup>5.)</sup>	0.027 <sup>5.)</sup>	24	Vac...2	2	PEEK	FFKM	355745	
<b>CF S</b> 3/2-way impulse solenoid valve Direct-acting Flow direction unrestricted 	Bürkert sub-base (9 x 26)	1.2	28	0.026	0.03	24	Vac...2	2	PPS	FKM	355756
						24			PEEK	FFKM	355754
						12			PEEK	FFKM	20005293
	UNF 1/4"-28	28 <sup>5.)</sup>	0.026 <sup>5.)</sup>	0.03 <sup>5.)</sup>	24	Vac...2	2	PEEK	FFKM	355755	

- 1.) Measurement at +20 °C, 1 bar at the valve inlet and free outlet
- 2.) Converted to standard conditions
- 3.) Pressure data: Overpressure to atmospheric pressure
- 4.) Connect technical vacuum (-0.8 bar) to NC or NO. If vacuum is connected to (COM/OUT), significantly reduced flow must be expected.
- 5.) K<sub>v</sub> value of the valve. The UNF connections have a diameter of 1.2 mm; in conjunction with conventional connection technology (10 cm hose each with ID=1.6 mm), this results in practical values of K<sub>v</sub>=0.015 m<sup>3</sup>/h; C<sub>v</sub>=0.017 gpm; Q<sub>Nn</sub>=21.8 l/min.

DTS 1000262565 EN Version: T Status: RL (released | freigegeben | validé) printed: 24.04.2024

### 8.4. Ordering chart accessories

#### Manifolds

**Note:**  
Customised for connecting plates, on request.

#### Cable plug Type 2503

**Note:**  
Special custom-built manifolds are available on request.

Accessories	Description	Article no.
	Cable plug with 500 mm flying leads AWG 24 For further information please refer to data sheet <b>Type 2503</b> ▶.	689974
	Cable plug with 500 mm flying leads and boost-close electronics to increase the permissible pressure under NC. For further information refer to the operating instructions for <b>Type 2503</b> ▶ <b>BoostClose</b> or see data sheet <b>Type 2503</b> ▶.	689998
	Cable plug with 500 mm flying leads and Soft Close Elektronik for noise minimization. For further information refer to the operating instructions for <b>Type 2503</b> ▶ <b>SoftClose</b> or see data sheet <b>Type 2503</b> ▶.	689999
	The electronic accessory "Impulse" was specially developed for the impulse version of the solenoid valve Type 6724. With the help of the electronics, the impulse valve is activated by reversing the polarity of the voltage. The electronics automatically choose the correct polarity for the valve. This means that no polarity reversal logic needs to be provided in the control system. For further information refer to the operating instructions for <b>Type 2503</b> ▶ <b>Impulse</b> or see data sheet <b>Type 2503</b> ▶.	366210

#### Fittings and hoses

Accessories	Description	Article no.
	Fittings and hoses for UNF connections and hoses see type <b>Type TVU003</b> ▶.	see data sheet <b>TVU003</b> ▶

DTS 1000262565 EN Version: T Status: RL (released | freigegeben | valide) printed: 24.04.2024