



Electromotive 2-way diaphragm control valve

- Safety position through energy storage
- Adjustable driving force
- Diagnostics functions and fieldbus connection
- Wetted surfaces in Ra ≤ 0.38 µm...1.6 µm (optionally electropolished)
- Available in nominal diameters DN 06...DN 100

Product variants described in the data sheet may differ from the product presentation and description.

Can be combined with

	Type SV02 Diaphragms	▶
	Type ME61 EDIP process display	▶
	Type ME63 Industrial Ethernet gateway, IP65/ IP67/ IP69k	▶
	Type ME43 Fieldbus gateway	▶
	Type 8098 FLOWave SAW flowmeter	▶

Type description

The externally controlled Type 3363 diaphragm valve consists of an electrically controlled linear actuator (positioner), a diaphragm and a 2-way valve body. The electric actuator with ball screw ensures usage under hygienic or aggressive ambient conditions. The flow-optimised valve body with minimum dead space enables high flow values and a wide range of possible applications. An optional energy storage device guarantees the safety position in the event of a power failure. The position is indicated by means of a 360° LED light ring. The actuator has a drive force adjustment to protect the diaphragm. A correspondingly high IP protection IP65/IP67 ensures adequate splash protection. The electromotive actuator of the diaphragm valve with ball screw moves to the desired end position at a particularly high speed of up to 4 mm/s. Moreover, the valve is also equipped with a mechanical position indicator and corresponding explosion protection ATEX/ II 3G Ex ec IIC T4 Gc/II 3D Ex tc IIIC T135 °C Dc.

DTS 1000303711 EN Version: P Status: RL (released | freigegeben | validé) printed: 19.06.2024

FLU-TECH CO. LTD.

Email: sales@flutech.co.th **Website:** https://flutech.co.th

Tel: 02-384-6060, 086-369-5871-3 **Fax:** 02-384-5701 **LINE OA:** @flutech.co.th

Address (HQ): 845/3-4, Moo 3, Theparak Rd., T. Theparak, A. Mueang Samut Prakan, Samut Prakan, 10270, Thailand



Table of contents

1. General technical data	4
2. Approvals and conformities	6
2.1. General notes.....	6
2.2. Conformity	6
2.3. Standards.....	6
2.4. Explosion protection	6
2.5. North America (USA/Canada)	6
2.6. Foods and beverages/Hygiene	6
2.7. Others	7
Oxygen.....	7
3. Materials	8
3.1. Bürkert resistApp	8
3.2. Pressure temperature diagram for plastic body.....	8
3.3. Material specifications	9
3.4. Example of available membrane materials	9
4. Dimensions	10
4.1. Actuator	10
AG2	10
AG3	11
4.2. Forged steel valve body (VS) with welded connection	12
4.3. Forged steel valve body (VS) with clamp connection	14
4.4. Tube valve body (VP) with welded connection	16
4.5. Tube valve body (VP) with clamp connection	17
4.6. Tube valve body (VP) with threaded connection.....	18
4.7. Tube valve body (VP) with flange connection	19
4.8. Cast valve body (VG) with welded connection	20
4.9. Cast valve body (VG) with clamp connection	22
4.10. Plastic body (PV, PD, PP) with spigot connections.....	23
4.11. Plastic body (PV, PD, PP) with true union	24
4.12. Plastic body (PV, PD, PP) with flange connection.....	25
5. Performance specifications	26
5.1. Fluidic data	26
Flow characteristics	26
5.2. Operating limits.....	27
Medium pressure	27
Operating limits for ambient and medium temperature	28
5.3. Electrical control and interfaces.....	30
Interface diagram	30
6. Product design and assembly	31
6.1. Product features.....	31
6.2. Product assembly	34
Structure of electromotive diaphragm valve Type 3363 AG2.....	34
Structure of electromotive diaphragm valve Type 3363 AG3.....	35
7. Ordering information	36
7.1. Bürkert eShop	36
7.2. Bürkert product filter.....	36
7.3. Bürkert Product Enquiry Form	36

7.4.	Ordering chart accessories	37
	Standard accessories	37
	Accessories cable	37
	Bürkert accessories	37



1. General technical data

Note:

- AG2: actuator size 2 with a nominal force of 2500 N for diaphragm size 8...40
- AG3: actuator size 3 with a nominal force of 11500 N for diaphragm size 40...100

Product properties	
Dimensions	Further information can be found in chapter "4. Dimensions" on page 10.
Material	
Forged steel valve body (VS) ¹⁾	Forged material 1.4435 according to BN2 DIN EN 10222-5, F316L according to ASTM A182/A182M and 316 I according to ASME BPE
Stainless steel block material (VI etc.) ¹⁾	Bloc material 1.4435 according to BN2 and 316L according to ASME BPE table DT-3
Tube valve body (VP) ¹⁾	Stainless steel tube 1.4435-BN2 / UNS S31603 (316L) according to DIN 11866, ASTM A269 / A270, DIN EN 10217-7 / 10216-5
Cast valve body (VG) ¹⁾	Investment cast material 1.4435 / 316 I
Design	Diaphragm control valve
Diaphragm	EPDM (AD) ¹⁾ , PTFE/EPDM (EA) ¹⁾ , Advanced PTFE/EPDM (EU) ¹⁾ , laminate of GYLON® and EPDM (ER) ¹⁾
Diaphragm size	8...100, for plastic body 15...100
Plastic body (PV, PD, PP) ¹⁾	PVC (PVC-U), PVDF, PP
Standard surface quality²⁾	
Forged steel valve body (VS) ¹⁾	Internally electrically polished: Ra ≤ 0.38 µm (NO17) ¹⁾ (ASME BPE SF4/DIN HE4) (externally forged surface, electrically polished) Internally mechanically polished: Ra ≤ 0.5 µm (NO14) ¹⁾ (ASME BPE SF1) (externally forged surface)
Stainless steel block material (VI etc.) ¹⁾	Internally electrically polished: Ra ≤ 0.38 µm (NO17) ¹⁾ (ASME BPE SF4/DIN HE4) (externally electrically polished) Internally mechanically polished: Ra ≤ 0.5 µm (NO14) ¹⁾ (ASME BPE SF1) (externally mechanically machined)
Tube valve body (VP) ¹⁾	Internally electrically polished: Ra ≤ 0.38 µm (NO17) ¹⁾ (ASME BPE SF4/DIN HE4) (externally electrically polished) Internally glass-bead blasted: Ra ≤ 1.6 µm (NO05) ¹⁾ (externally glass-bead blasted)
Cast valve body (VG) ¹⁾	Internally electrically polished: Ra ≤ 0.6 µm (NO16) ¹⁾ (ASME BPE SF6) ³⁾ (externally cast surface, electrically polished) ³⁾ Internally mechanically polished: Ra ≤ 0.76 µm (NO06) ¹⁾ (ASME BPE SF3/DIN H2) (externally cast surface)
Safety setting in case of power failure	With energy storage SAFEPOS energy-pack: open, closed or freely programmable Without energy storage SAFEPOS energy-pack: blocked in last position
Service life of energy storage SAFEPOS energy-pack	Up to 10 years (depending on operating conditions)
Controller variant	Positioner or process controller (option)
Performance data	
Closing time	AG2: 1.5...4.5 s AG3: 5.7...12.0 s (Depending on travel speed, stroke and operating conditions)
Travel speed	4 mm/s (for AG2 actuator force 2500 N) 3 mm/s (for AG3 actuator force 11500 N)
Dead band of the positioner	± 0.4 %

Electrical data	
Operating voltage	24 V DC \pm 10 % (maximum residual ripple 10 %)
Operating current ^{4.)}	AG2: maximum 3 A (at maximum load and including 1 A charging current of the optional energy storage SAFEPOS energy-pack). At minimum operating temperature additionally 2 A AG3: maximum 5 A (at maximum load and including charging current of the optional energy storage SAFEPOS energy-pack). At minimum operating temperature additionally 6 A
Protection class (DIN EN 61140)	III
Duty cycle	100 %
Standby consumption ^{4.)}	1...5 W
Communication and control	
Standard signal (analogue)	Set-point value: 0/4...20 mA, 0...5/10 V and binary input (further inputs and outputs optional (see "5.3. Electrical control and interfaces" on page 30)
Fieldbus (digital)	Bürkert system bus (bÜS) CANopen (option) EtherNet/IP, PROFINET, Modbus TCP (option via integrated gateway)
Medium data	
Process medium	Neutral gases and fluids, highly purified, sterile, aggressive or abrasive mediums (see chemical resistance chart ▶)
Medium temperature	
EPDM (AD) ^{1.)}	-10...+143 °C (steam sterilisation +150 °C for 60 min)
PTFE/EPDM (EA) ^{1.)}	-10...+130 °C (steam sterilisation +140 °C for 60 min)
Advanced PTFE/EPDM (EU) ^{1.)}	-5...+143 °C (steam sterilisation +150 °C for 60 min)
Laminate of GYLON® and EPDM (ER) ^{1.)}	-5...+130 °C (steam sterilisation +140 °C for 60 min)
Plastic body	See "3.2. Pressure temperature diagram for plastic body" on page 8
Process/Port connection & communication	
Nominal diameter (port connection)	DN 06...DN 100 (1/8" ... 4")
Port connection ^{2.)}	
For stainless steel body^{5.)}	
Welded connection ^{2.)}	DIN EN ISO 1127 / ISO 4200 / DIN 11866 series B DIN 11850-2 / DIN 11866 series A / DIN EN 10357 series A ASME BPE / DIN 11866 series C
Clamp connection ^{2.)}	DIN 32676 series A (DIN pipe) DIN 32676 series B (ISO pipe) ASME BPE
For plastic body	
Spigot connection	DN 15...DN 50
True union	DN 15...DN 50
Loose flange	DN 15...DN 65
Fixed flange	DN 80...DN 100
Electrical connection	
Actuator	Terminal strip with cable gland (only AG2), 2 x M20 or 2 x M12 circular plugs, 5-pin and 8-pin
Fieldbus gateway	2 x M12 circular sockets, 4-pin (only with Industrial Ethernet)
Approvals and conformities	
Further information can be found in chapter "2. Approvals and conformities" on page 6.	
Detergent resistance	According to Ecolab test method: R&D/P3-E No. 40-1
Environment and installation	
Ambient temperature	-10 °C...+65 °C ^{6.)} (without display) -10 °C...+60 °C ^{6.)} (with display) -10 °C...+55 °C ^{6.)} (with energy storage SAFEPOS energy-pack) Derating see "5.2. Operating limits" on page 27
Degree of protection	IP65/IP67 (DIN EN 60529), NEMA 4X
Installation position	As required, preferably with actuator upright

1.) This information is part of the product key (see "7.3. Bürkert Product Enquiry Form" on page 36).

2.) Other port connections are available on request.

3.) Only up to DN 50, not available for DN 65...100

3.) All values relate to a supply voltage of 24 V at +25 °C.

5.) Tube valve body (VP) also available with flange and threaded connections

6.) Depends on medium temperature, see chapter "Operating limits for ambient and medium temperature" on page 28

2. Approvals and conformities

2.1. General notes

- The approvals and conformities listed below must be stated when making enquiries. This is the only way to ensure that the product complies with all required specifications.
- Not all available versions can be supplied with the below mentioned approvals or conformities.



2.2. Conformity

In accordance with the Declaration of Conformity, the product is compliant with the EU Directives.

2.3. Standards

The applied standards which are used to demonstrate compliance with the EU Directives are listed in the EU-Type Examination Certificate and/or the EU Declaration of Conformity.



2.4. Explosion protection

Approval	Description
 	<p>Optional: Explosion protection (valid for the variable code PX48) As a category 3 device suitable for zone 2/22.</p> <p>ATEX: BVS 17 ATEX E 117 X II 3G Ex ec IIC T4 Gc II 3D Ex tc IIIC T135 °C Dc</p> <p>IECEX: IECEX BVS 17.0100X Ex ec IIC T4 Gc Ex tc IIIC T135 °C Dc</p>

2.5. North America (USA/Canada)

Approval	Description
	<p>Optional: Actuators UL Listed for the USA and Canada (valid for the variable code PU11) The actuators are UL Listed for the USA and Canada according to:</p> <ul style="list-style-type: none"> • UL 61010-1 (ELECTRICAL EQUIPMENT FOR MEASUREMENT, CONTROL, AND LABORATORY USE – Part 1: General Requirements) • CAN/CSA-C22.2 No. 61010-1

2.6. Foods and beverages/Hygiene

Conformity	Description
	<p>3-A Sanitary Standards Inc. (valid for the variable code PE05) The products comply with 3-A Sanitary Standards Inc (3-A SSI) as per certificate.</p>
<p>FDA</p>	<p>FDA – Code of Federal Regulations The diaphragms made of EPDM (AD), PTFE/EPDM (EA), Advanced PTFE/EPDM (EU) and laminate of GYLON® and EPDM (ER) comply with the Code of Federal Regulations published by the FDA (Food and Drug Administration, USA).</p>
<p>USP</p>	<p>United States Pharmacopeial Convention (USP) The diaphragms made of EPDM (AD), PTFE/EPDM (EA), Advanced PTFE/EPDM (EU) and laminate of GYLON® and EPDM (ER) are tested according to USP Class VI.</p>
	<p>EC Regulation 1935/2004 of the European Parliament and of the Council The diaphragms made of EPDM (AD), PTFE/EPDM (EA), Advanced PTFE/EPDM (EU) and laminate of GYLON® and EPDM (ER) are suitable for use with food and beverages (according to EC Regulation 1935/2004/EC).</p>

DTS 1000303711 EN Version: P Status: RL (released | freigegeben | valide) printed: 19.06.2024

2.7. Others

Oxygen

Conformity	Description
O ₂	Optional: Suitability for oxygen (valid for the variable code NL02) The products are suitable for use with gaseous oxygen, according to the manufacturer's declaration.

DTS 1000303711 EN Version: P Status: RL (released | freigegeben | valide) printed: 19.06.2024



3. Materials

3.1. Bürkert resistApp

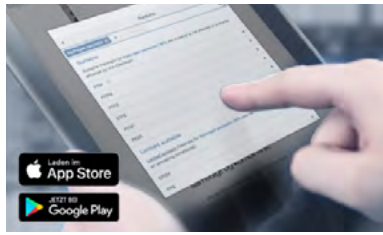

Bürkert resistApp – Chemical resistance chart

You want to ensure the reliability and durability of the materials in your individual application case? Verify your combination of media and materials on our website or in our resistApp.

[Start chemical resistance check](#)

3.2. Pressure temperature diagram for plastic body

Note:

This information is important for material selection. Observe the permissible operating pressure depending on the medium temperature.

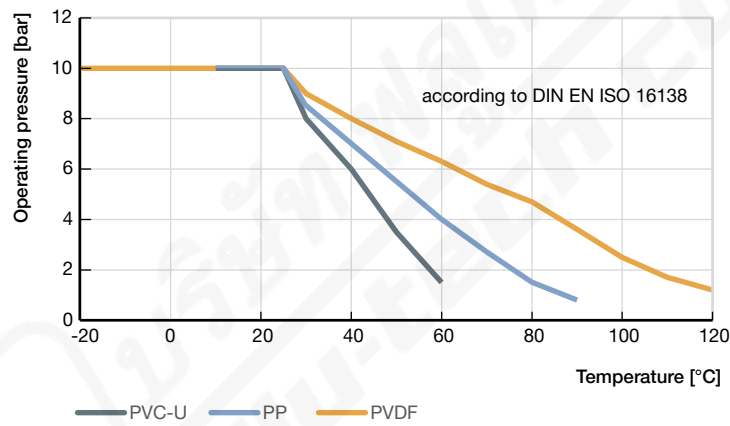

DTS 1000303711 EN Version: P Status: RL (released | freigegeben | validé) printed: 19.06.2024

3.3. Material specifications

Note:

The exemplary representation may differ from the actual product.

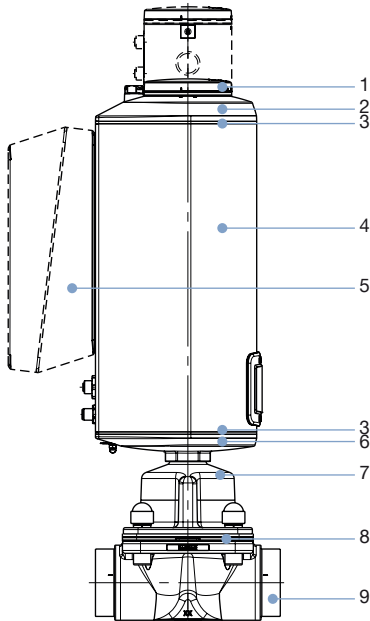

AG2

No.	Component	Material
1	Display housing/blind cover	PPS (standard), Stainless steel 1.4301 (for ATEX/IECEX)
2	Actuator cover	PPS
3	Seal	EPDM
4	Actuator housing	Powder-coated aluminium
6	Actuator base	PPS
7	Diaphragm bonnet	Stainless steel 1.4308
8	Diaphragm	EPDM (AD) PTFE/EPDM (EA) Advanced PTFE/EPDM (EU) Laminate of GYLON® and EPDM (ER)
9	Valve body	See "1. General technical data" on page 4

AG3

No.	Component	Material
1	Display housing/blind cover	PPS (standard), Stainless steel 1.4301 (for ATEX/IECEX)
2	Actuator cover	PC
3	Seal	EPDM
4	Actuator housing	Powder-coated aluminium
5	Energy storage SAFEPOS energy-pack housing	PC
6	Actuator base	Stainless steel 1.4308
7	Diaphragm bonnet	Stainless steel 1.4470
8	Diaphragm	EPDM (AD) PTFE/EPDM (EA) Advanced PTFE/EPDM (EU) Laminate of GYLON® and EPDM (ER)
9	Valve body	See "1. General technical data" on page 4

3.4. Example of available membrane materials

The diaphragms have been developed to meet the unique challenges of hygienic and sterile requirements. Bürkert offers diaphragms with precise material composition and high accuracy. Bürkert diaphragms are available in a wide range of materials which have been tested and proven in applications in the food and beverage, biotechnology, pharmaceutical and cosmetics industries. The diaphragms are tested during development and production to ensure reliability under difficult process conditions.



- EPDM (AD)
- PTFE/EPDM (EA)
- Advanced PTFE/EPDM (EU)
- Laminate of GYLON® and EPDM (ER)

For further information please refer to our flyer "Diaphragm competence for hygienic applications" on our [website](#) ►.

DTS 1000303711 EN Version: P Status: RL (released | freigegeben | validé) printed: 19.06.2024

4. Dimensions

4.1. Actuator

AG2

Note:

Dimensions in mm, unless otherwise stated

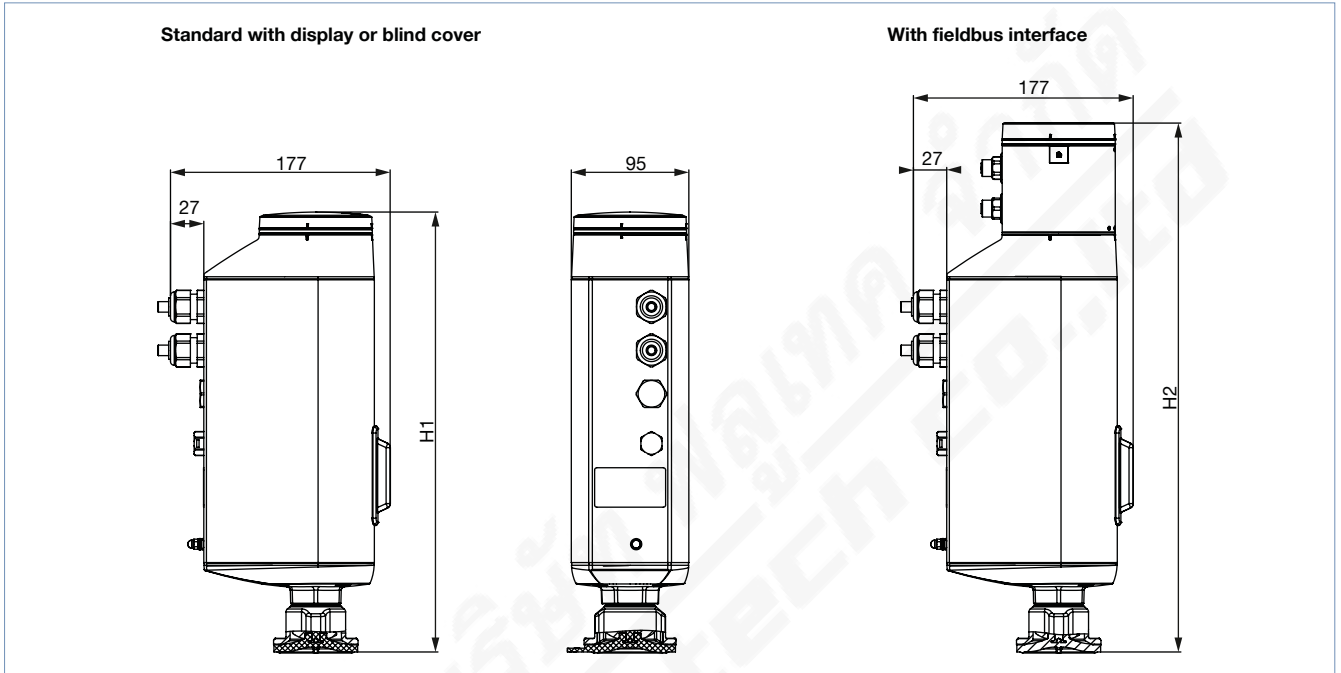

Diaphragm size	Height	
	H1 Standard variant	H2 ^{1.)} Fieldbus variant (KOMM ≠ G, N, L)
8	342	414
15	345	418
20	350	422
25	355	426
32	365	436
40	370	442

1.) Option: integrated fieldbus gateway

AG3

Note:

Dimensions in mm, unless otherwise stated

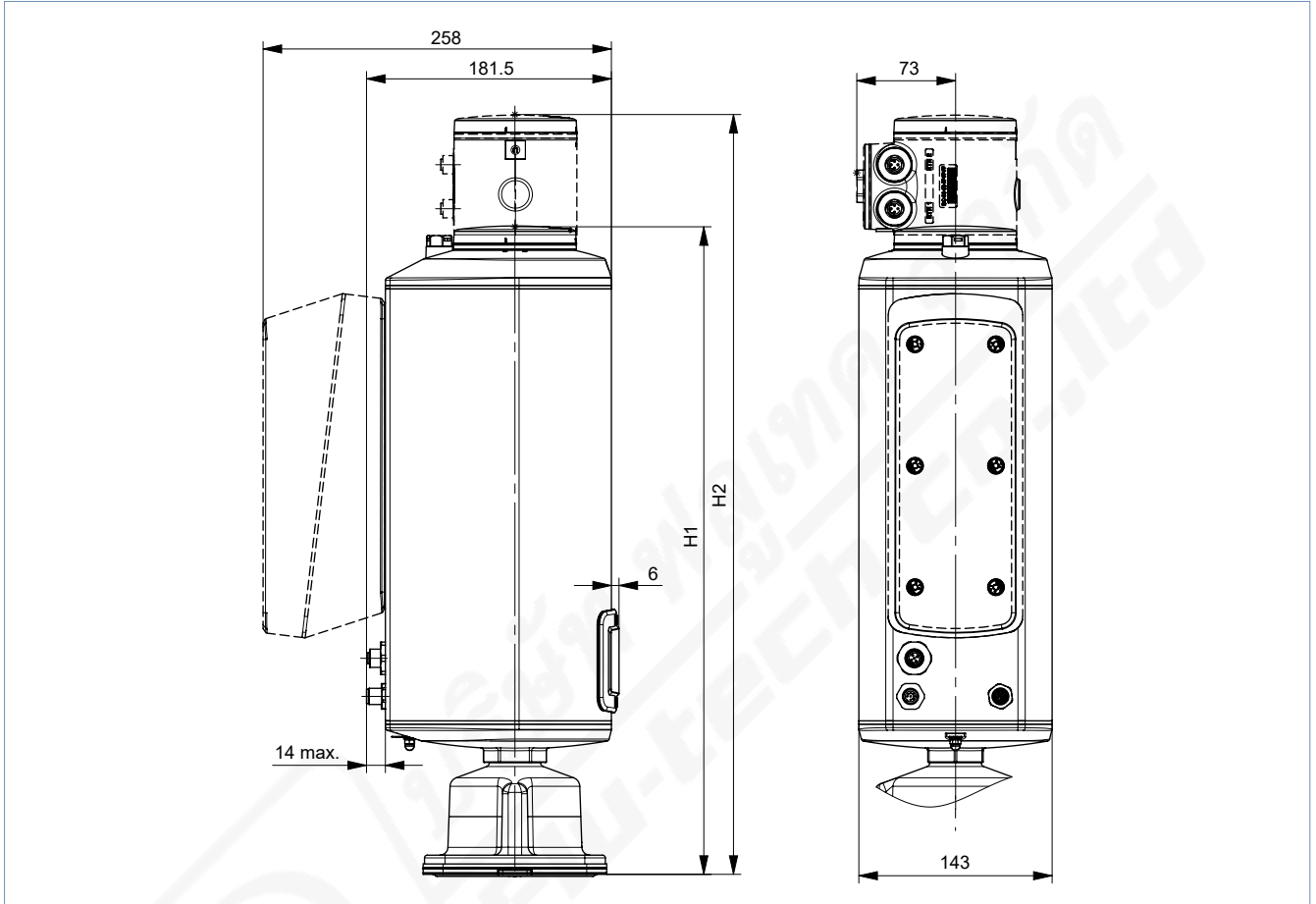

Diaphragm size	Height	
	H1 Standard variant	H2 ^{1.)} Fieldbus variant (KOMM ≠ G, N, L)
40	452	523
50	462	533
65	477	548
80	479	550
100	482	553

1.) Option: integrated fieldbus gateway

4.2. Forged steel valve body (VS) with welded connection

Note:

- Dimensions in mm, unless otherwise stated
- Further information on the draining angle can be found in the “Additional manual Type 2xxx 3xxx” on our website (see **operating instructions Type 3363** ▶).

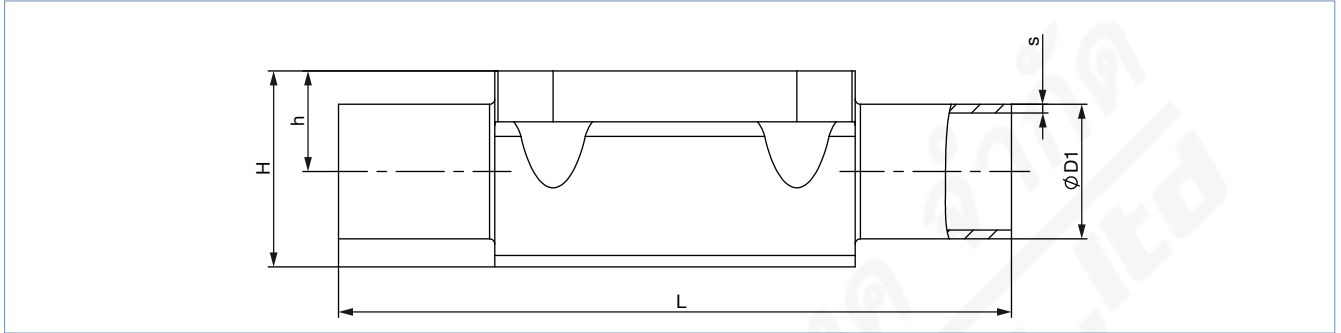

Diaphragm size	Port connection DN	ØD1	s	L	h	H	Product key ¹⁾
DIN EN ISO 1127 / ISO 4200 / DIN 11866 series B							
8	8	13.5	1.6	90	9.3	18.8	SA40
15	8	13.5	1.6	108	8.15	19.85	SA40
8	10	17.2	1.6	90	9.3	18.8	SA41
15	10	17.2	1.6	110	12.05	23.75	SA41
15	15	21.3	1.6	110	12.05	23.75	SA42
20	15	21.3	1.6	119	16	30.3	SA42
20	20	26.9	1.6	119	16	30.3	SA43
25	20	26.9	1.6	119	19	37	SA43
25	25	33.7	2.0	129	19	37	SA44
40	25	33.7	2.0	161	27.6	52.4	SA44
40	32	42.4	2.0	161	27.6	52.4	SA45
40	40	48.3	2.0	161	27.6	52.4	SA46
50	50	60.3	2.0	192	35.5	68.3	SA47
80	65	76.1	2.0	250	51	98.1	SA48
80	80	88.9	2.3	250	51	98.1	SA49
100 ²⁾	100	114.3	2.3	295	63.5	127.0	SA39
DIN 11850-2 / DIN 11866 series A / DIN EN 10357 series A							
8	10	13	1.5	90	9.3	18.8	SD40
15	10	13	1.5	110	8.15	19.85	SD40
15	15	19	1.5	110	12.05	23.75	SD42
20	20	23	1.5	119	16.0	30.3	SD43
25	25	29	1.5	129	19.0	37.0	SD44
40	32	35	1.5	161	27.6	52.4	SD45
40	40	41	1.5	161	27.6	52.4	SD46
50	50	53	1.5	192	35.5	68.3	SD47
80	65	70	2.0	250	51.0	98.1	SD48
80	80	85	2.0	250	51.0	98.1	SD49
100 ²⁾	100	104	2	295	63.5	127.0	SD50

DTS 1000303711 EN Version: P Status: RL (released | freigegeben | validé) printed: 19.06.2024

Diaphragm size	Port connection DN	ØD1	s	L	h	H	Product key ^{1.)}
ASME BPE / DIN 11866 series C							
8	¼"	6.35	0.89	78	5.7	15.2	SA90
8	⅜"	9.53	0.89	89	5.7	15.2	SA91
8	½"	12.7	1.65	89	9.3	18.8	SA92
15	½"	12.7	1.65	108	8.15	19.85	SA92
15	¾"	19.05	1.65	108	12.05	23.75	SA93
20	¾"	19.05	1.65	117	16.0	30.3	SA93
25	1"	25.4	1.65	127	19.0	37.0	SODF
40	1½"	38.1	1.65	159	27.6	52.4	SODH
50	2"	50.8	1.65	190	35.5	68.3	SODI
50	2½"	63.5	1.65	192	35.5	68.6	SODJ
80	2½"	63.5	1.65	250	51.0	98.1	SODJ
80	3"	76.2	1.65	250	51.0	98.1	SODK
100 ^{2.)}	4"	101.6	2.11	295	63.5	127.0	SODL
BS 4825							
8	8	6.35	1.20	78	5.7	15.2	SODB
8	10	9.53	1.20	89	5.7	15.2	SODC
15	15	12.7	1.20	108	8.15	19.85	SODD
20	20	19.05	1.20	117	16.0	30.3	SODE
25	25	25.4	1.65	127	19.0	37.0	SODF
40	40	38.1	1.65	159	27.6	52.4	SODH
50	50	50.8	1.65	190	35.5	68.3	SODI
50	65	63.5	1.65	192	35.5	68.6	SODJ
80	80	63.5	1.65	250	51.0	98.1	SODJ
80	80	76.2	1.65	250	51.0	98.1	SODK
SMS 3008							
25	25	25	1.2	129	19	37	SA60
40	40	38	1.2	161	27.6	52.4	SA62
50	50	51	1.2	192	35.5	68.3	SA63
100 ^{2.)}	100	101.6	2	295	63.5	127.0	SA66
DIN 11850 - 0							
8	6	8	1.0	90	5.7	15.2	SC41
8	8	10	1.0	90	5.7	15.2	SC42

1.) This information is part of the product key (see "7.3. Bürkert Product Enquiry Form" on page 36).

2.) Only available as block material

DTS 1000303711 EN Version: P Status: RL (released | freigegeben | validé) printed: 19.06.2024

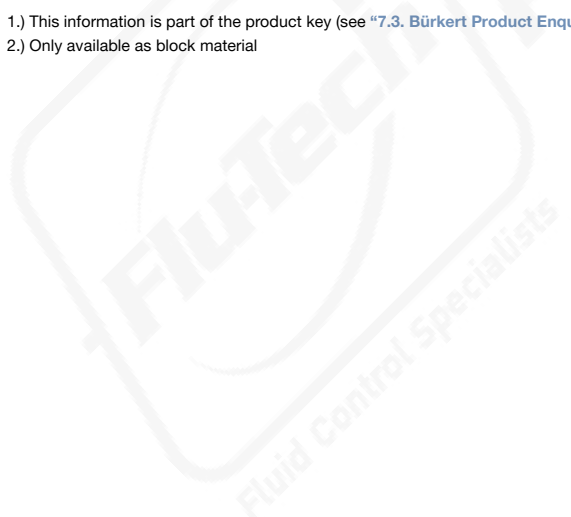

4.3. Forged steel valve body (VS) with clamp connection

Note:

- Dimensions in mm, unless otherwise stated
- Further information on the draining angle can be found in the “Additional manual Type 2xxx 3xxx” on our website (see **operating instructions Type 3363** ▶).

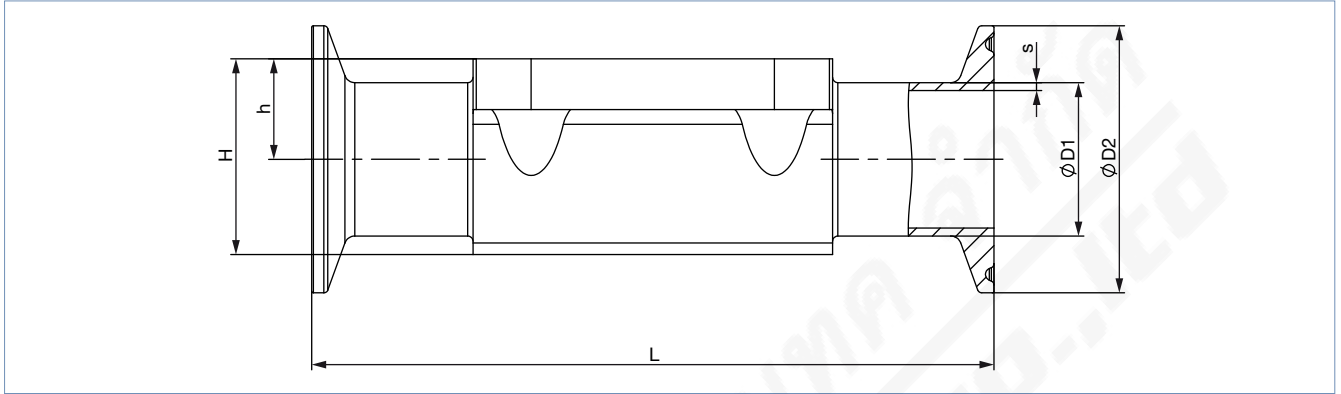

Diaphragm size	Port connection DN	ØD1	s	ØD2	L	h	H	Product key ¹⁾	Variable code ¹⁾
DIN 32676 series B (ISO pipe)									
8	8	13.50	1.60	25.00	90.00	9.30	18.80	TC40	–
8	10	17.20	1.60	25.00	89.00	9.30	18.80	TC53	–
15	8	13.50	1.60	25.00	89.00	8.15	19.85	TC40	–
15	15	21.30	1.60	50.50	167.00	12.05	23.75	TC52	AF79
20	20	26.90	1.60	50.50	114.00	16.00	30.30	TC43	AF79+AG42
25	25	33.70	2.00	50.50	129.00	19.00	37.00	TC44	–
40	40	48.30	2.00	64.00	161.00	27.60	52.40	TC46	–
50	50	60.30	2.00	77.50	190.00	35.50	68.30	TC47	–
65	65	76.10	2.00	91.00	190.00	35.50	68.30	TC48	–
80	80	88.90	2.30	106.00	222.00	51.00	98.10	TC49	–
100 ²⁾	100	114.30	2.30	130.00	350.00	63.50	127.00	TC50	–
DIN 32676 series A (DIN pipe)									
8	6	8.00	1.00	25.00	89.00	5.70	15.20	TD39	–
8	8	10.00	1.00	25.00	90.00	5.70	15.20	TD40	–
8	10	13.00	1.50	34.00	126.00	9.30	18.80	TD41	AF79
15	10	13.00	1.50	34.00	110.00	8.15	19.85	TD41	–
15	15	19.00	1.50	34.00	110.00	12.05	23.75	TD42	–
20	20	23.00	1.50	34.00	119.00	16.00	30.30	TD43	–
25	25	29.00	1.50	50.50	129.00	19.00	37.00	TD44	–
40	40	41.00	1.50	50.50	161.00	27.60	52.40	TD46	–
50	50	53.00	1.50	64.00	192.00	35.50	68.30	TD47	–
65	65	70.00	2.00	91.00	248.00	43.00	83.50	TD48	–
80	65	70.00	2.00	91.00	222.00	51.00	98.10	TD48	–

DTS 1000303711 EN Version: P Status: RL (released | freigegeben | validé) printed: 19.06.2024

ASME BPE									
8	¼"	6.35	0.89	25.00	64.50	5.70	15.20	TG50	–
8	⅜"	9.53	0.89	25.00	89.00	5.70	15.20	TG01	AF34
8	½"	12.70	1.65	25.00	64.00	9.30	18.80	TG02	–
8	½"	12.70	1.65	25.00	89.00	9.30	18.80	TG02	AF34
15	½"	12.70	1.65	25.00	89.00	8.15	19.85	TG02	–
15	½"	12.70	1.65	25.00	108.00	8.15	19.85	TG02	AF34
15	¾"	19.05	1.65	25.00	89.00	12.05	23.75	TG03	–
20	¾"	19.05	1.65	25.00	102.00	16.00	30.30	TG03	–
20	¾"	19.05	1.65	25.00	117.00	16.00	30.30	TG03	AF34
25	1"	25.40	1.65	50.50	114.00	19.00	37.00	TG04	–
25	1"	25.40	1.65	50.50	127.00	19.00	37.00	TG04	AF34
40	1 ½"	38.10	1.65	50.50	140.00	27.60	52.40	TG05	–
40	1 ½"	38.10	1.65	50.50	159.00	27.60	52.40	TG05	AF34
50	2"	50.80	1.65	64.00	159.00	35.50	68.30	TG06	–
50	2"	50.80	1.65	64.00	190.00	35.50	68.30	TG06	AF34
65	2 ½"	63.50	1.65	77.50	249.00	43.00	83.50	TG07	–
80	2 ½"	63.50	1.65	77.50	216.00	51.00	98.10	TG07	–
80	3"	76.20	1.65	91.00	222.00	51.00	98.10	TG08	–
100 ^{2.)}	4"	101.60	2.11	119.00	306.00	63.50	127.00	TG09	–

1.) This information is part of the product key (see "7.3. Bürkert Product Enquiry Form" on page 36).

2.) Only available as block material



4.4. Tube valve body (VP) with welded connection

Note:

- Dimensions in mm, unless otherwise stated
- Further information on the draining angle can be found in the “Additional manual Type 2xxx 3xxx” on our website (see **operating instructions Type 3363** ▶).

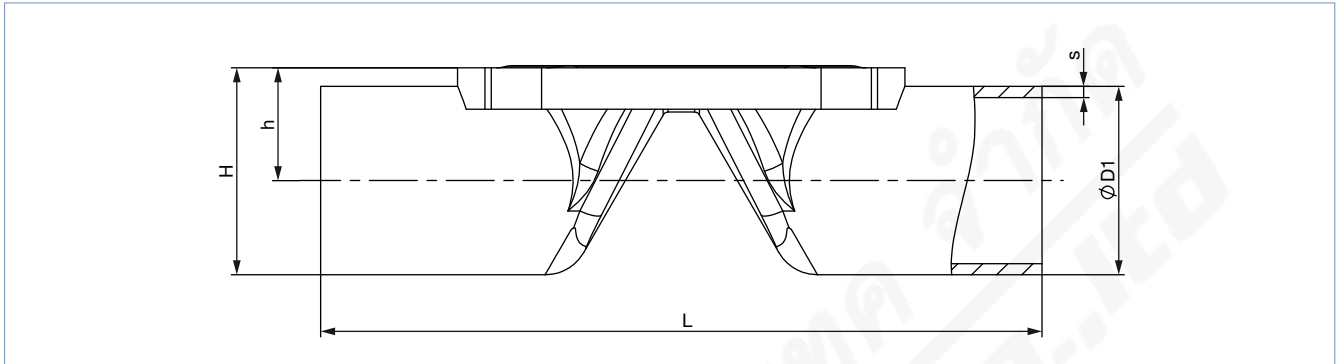

Diaphragm size	Port connection DN	ØD1	s	L	h	H	Product key ^{1.)}
DIN EN ISO 1127 / ISO 4200 / DIN 11866 series B							
8	8	13.50	1.60	90.00	9.45	16.20	SA40
8	10	17.20	1.60	90.00	11.30	19.90	SA41
15	15	21.30	1.60	110.00	13.95	24.60	SA42
20	20	26.90	1.60	119.00	16.75	30.20	SA43
25	25	33.70	2.00	129.00	20.15	37.00	SA44
32	32	42.40	2.00	148.00	24.70	45.90	SA45
40	40	48.30	2.00	161.00	28.95	53.10	SA46
50	50	60.30	2.00	192.00	34.95	65.10	SA47
DIN 11850-2 / DIN 11866 series A / DIN EN 10357 series A							
8	10	13.00	1.50	90.00	9.45	16.00	SD40
15	15	19.00	1.50	110.00	12.80	22.30	SD42
15	20	23.00	1.50	119.00	14.80	26.30	SD43
20	25	29.00	1.50	129.00	17.80	32.30	SD44
25	32	35.00	1.50	148.00	20.80	38.30	SD45
32	40	41.00	1.50	161.00	24.00	44.50	SD46
40	50	53.00	1.50	192.00	31.30	57.80	SD47
ASME BPE / DIN 11866 series C							
8	½"	12.70	1.65	90.00	9.05	15.40	SA92
15	¾"	19.05	1.65	117.00	12.83	22.35	SA93
20	1"	25.40	1.65	127.00	16.00	28.70	SODF
32	1 ½"	38.10	1.65	159.00	22.55	41.60	SODH
40	2"	50.80	1.65	190.00	30.20	55.60	SODI
50	2 ½"	63.50	1.65	192.00	36.75	68.50	SODJ
65	3"	76.20	1.65	250.00	46.30	84.40	SODK
80	4"	101.60	2.11	295.00	60.00	110.80	SODL

1.) This information is part of the product key (see “7.3. Bürkert Product Enquiry Form” on page 36).

DTS 1000303711 EN Version: P Status: RL (released | freigegeben | validé) printed: 19.06.2024

4.5. Tube valve body (VP) with clamp connection

Note:

- Dimensions in mm, unless otherwise stated
- Further information on the draining angle can be found in the “Additional manual Type 2xxx 3xxx” on our website (see **operating instructions Type 3363** ▶).

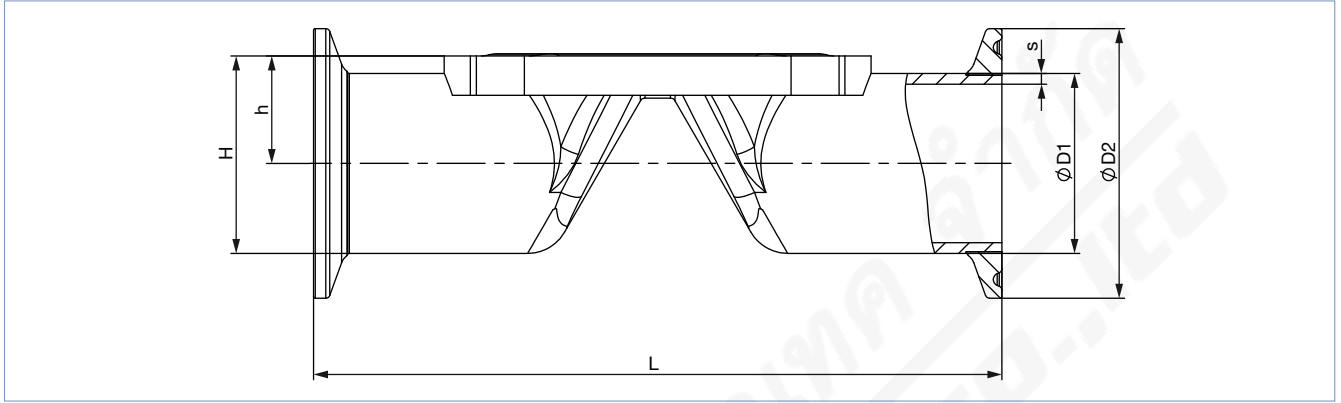

Diaphragm size	Port connection DN	ØD1	s	ØD2	L	h	H	Product key ^{1.)}
DIN 32676 series B (ISO pipe)								
8	8	13.50	1.60	25.00	89.00	9.45	16.20	TC40
8	10	17.20	1.60	25.00	89.00	11.30	19.90	TC53
15	15	21.30	1.60	50.50	110.00	13.95	24.60	TC52
20	20	26.90	1.60	50.50	119.00	16.75	30.20	TC43
25	25	33.70	2.00	50.50	129.00	20.15	37.00	TC44
32	32	42.40	2.00	64.00	148.00	24.70	45.90	TC55
40	40	48.30	2.00	64.00	161.00	28.95	53.10	TC46
50	50	60.30	2.00	77.50	192.00	34.95	65.10	TC47
DIN 32676 series A (DIN pipe)								
8	10	13.00	1.50	34.00	89.00	9.45	16.00	TD41
15	15	19.00	1.50	34.00	110.00	12.80	22.30	TD42
15	20	23.00	1.50	34.00	119.00	14.80	26.30	TD43
20	25	29.00	1.50	50.50	129.00	17.80	32.30	TD44
25	32	35.00	1.50	50.50	148.00	20.80	38.30	TD45
32	40	41.00	1.50	50.50	161.00	24.00	44.50	TD46
40	50	53.00	1.50	64.00	192.00	31.30	57.80	TD47
ASME BPE								
8	½"	12.70	1.65	25.00	89.00	9.05	15.40	TG02
15	¾"	19.05	1.65	25.00	102.00	12.83	22.35	TG03
20	1"	25.40	1.65	50.50	114.00	16.00	28.70	TG04
32	1 ½"	38.10	1.65	50.50	140.00	22.55	41.60	TG05
40	2"	50.80	1.65	64.00	159.00	30.20	55.60	TG06
50	2 ½"	63.50	1.65	77.50	190.00	36.75	68.50	TG07

1.) This information is part of the product key (see “7.3. Bürkert Product Enquiry Form” on page 36).

DTS 1000303711 EN Version: P Status: RL (released | freigegeben | validé) printed: 19.06.2024

4.6. Tube valve body (VP) with threaded connection

Note:

- Dimensions in mm, unless otherwise stated
- Further information on the draining angle can be found in the “Additional manual Type 2xxx 3xxx” on our website (see **operating instructions Type 3363** ▶).

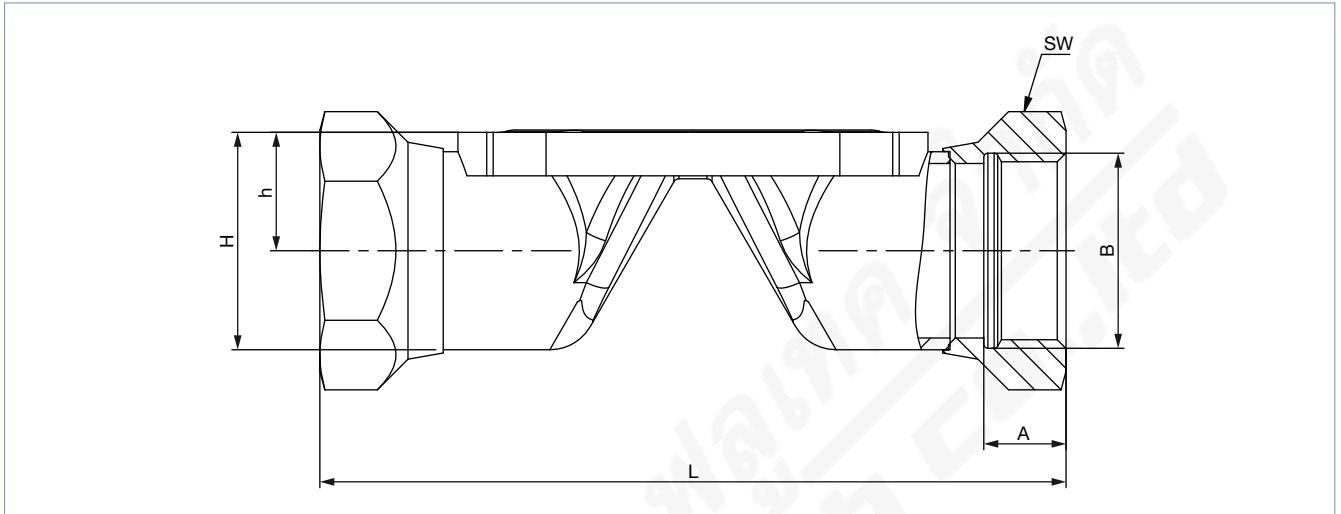

Diaphragm size	L	A	B	h	H	Spanner width of threaded ports	Product key ^{1.)}
8	85.00	8.00	G ¼	9.45	16.20	17	GM82
15	102.00	14.00	G ½	13.95	24.60	27	GM84
20	118.00	12.00	G ¾	16.75	30.20	32	GM85
25	127.00	14.00	G 1	20.15	37.00	41	GM86
32	146.00	16.00	G 1 ¼	24.70	45.90	50	GM87
40	159.00	18.00	G 1 ½	28.95	53.10	60	GM88
50	191.00	20.00	G 2	34.95	65.10	70	GM89
Diaphragm size	L	A	B	h	H	Spanner width of threaded ports	Product key ^{1.)}
8	58.00	9.70	Rc ¼	9.45	16.20	17	RC82
15	102.00	13.20	Rc ½	13.95	24.60	27	RC84
20	118.00	14.50	Rc ¾	16.75	30.20	32	RC85
25	127.00	16.80	Rc 1	20.15	37.00	41	RC86
32	146.00	19.10	Rc 1 ¼	24.70	45.90	50	RC87
40	159.00	19.10	Rc 1 ½	28.95	53.10	60	RC88
50	191.00	23.40	Rc 2	34.95	65.10	70	RC89
Diaphragm size	L	A	B	h	H	Spanner width of threaded ports	Product key ^{1.)}
8	85.00	10.00	NPT ¼	9.45	16.20	17	NM82
15	102.00	13.70	NPT ½	13.95	24.60	27	NM84
20	118.00	14.00	NPT ¾	16.75	30.20	32	NM85
25	127.00	16.80	NPT 1	20.15	37.00	41	NM86
32	146.00	17.30	NPT 1 ¼	24.70	45.90	50	NM87
40	159.00	17.30	NPT 1 ½	28.95	53.10	60	NM88
50	191.00	17.60	NPT 2	34.95	65.10	70	NM89

1.) This information is part of the product key (see “7.3. Bürkert Product Enquiry Form” on page 36).

DTS 1000303711 EN Version: P Status: RL (released | freigegeben | valide) printed: 19.06.2024

4.7. Tube valve body (VP) with flange connection

Note:

- Dimensions in mm, unless otherwise stated
- Further information on the draining angle can be found in the “Additional manual Type 2xxx 3xxx” on our website (see **operating instructions Type 3363** ▶).

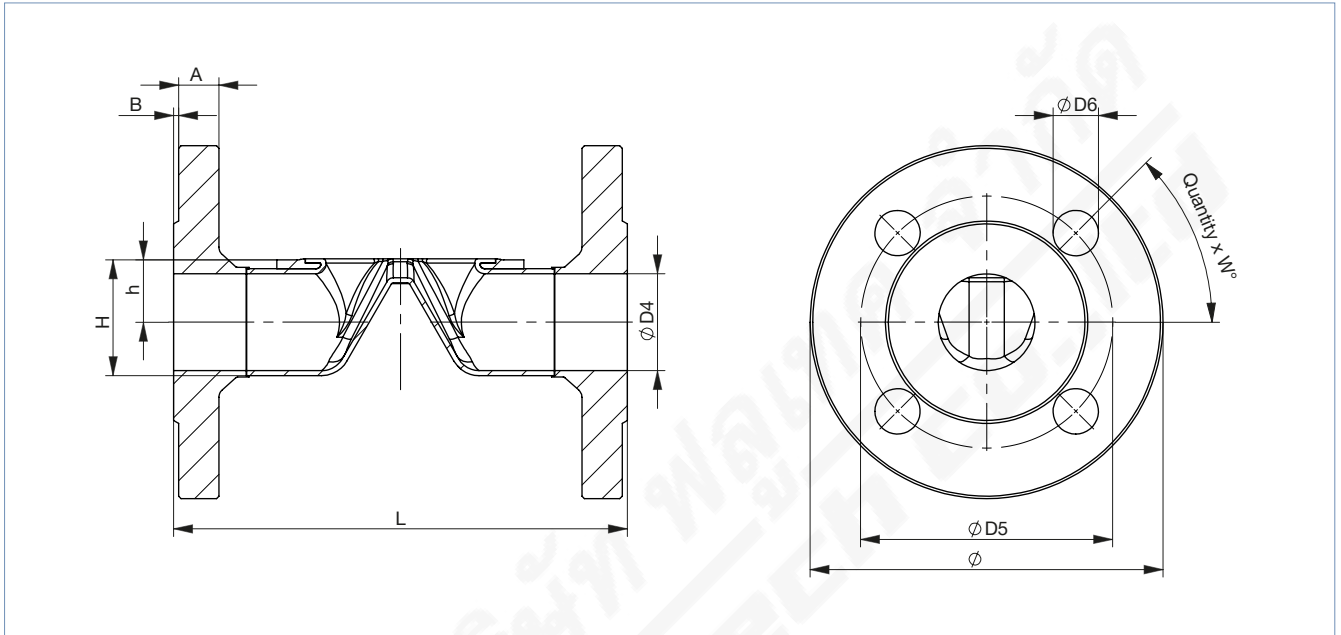

Diaphragm size	L	h	H	Ø D3	Ø D4	Ø D5	Ø D6	W	A	B	Product key ^{1.)}
DIN EN 1092 - 1											
15	130.00	13.95	24.60	95.00	18.10	65.00	14.00	4 x 45°	14.00	2.00	FD22
20	150.00	16.75	30.20	105.00	23.70	75.00	14.00		16.00	2.00	FD23
25	160.00	20.15	37.00	115.00	29.70	85.00	14.00		16.00	2.00	FD24
32	180.00	24.70	45.90	140.00	38.40	100.00	18.00		16.00	2.00	FD25
40	200.00	28.95	53.10	150.00	44.30	110.00	18.00		15.00	3.00	FD26
50	230.00	34.95	65.10	165.00	56.30	125.00	18.00		17.00	3.00	FD27
ANSI B16.5											
15	130.00	12.80	22.30	89.00	15.70	60.50	15.70	4 x 45°	9.60	1.60	FA02
20	150.00	16.75	30.20	99.00	20.80	69.90	15.70		11.10	1.60	FA03
25	160.00	20.15	37.00	108.00	26.70	79.20	15.70		12.60	1.60	FA04
40	200.00	28.95	53.10	127.00	40.90	98.60	15.70		15.90	1.60	FA06
50	230.00	34.95	65.10	152.00	52.60	120.70	19.10		17.50	1.60	FA07
JIS 10K											
15	130.00	13.95	24.60	95.00	18.10	70.00	15.00	4 x 45°	11.00	1.00	FJ01
20	150.00	16.75	30.20	100.00	23.70	75.00	15.00		13.00	1.00	FJ02
25	160.00	20.15	37.00	125.00	29.70	90.00	19.00		13.00	1.00	FJ03
40	200.00	28.95	53.10	140.00	44.30	105.00	19.00		14.00	2.00	FJ05
50	230.00	34.95	65.10	155.00	56.30	120.00	19.00		14.00	2.00	FJ06

1.) This information is part of the product key (see “7.3. Bürkert Product Enquiry Form” on page 36).

DTS 1000303711 EN Version: P Status: RL (released | freigegeben | validé) printed: 19.06.2024

4.8. Cast valve body (VG) with welded connection

Note:

- Dimensions in mm, unless otherwise stated
- Further information on the draining angle can be found in the “Additional manual Type 2xxx 3xxx” on our website (see **operating instructions Type 3363** ▶).

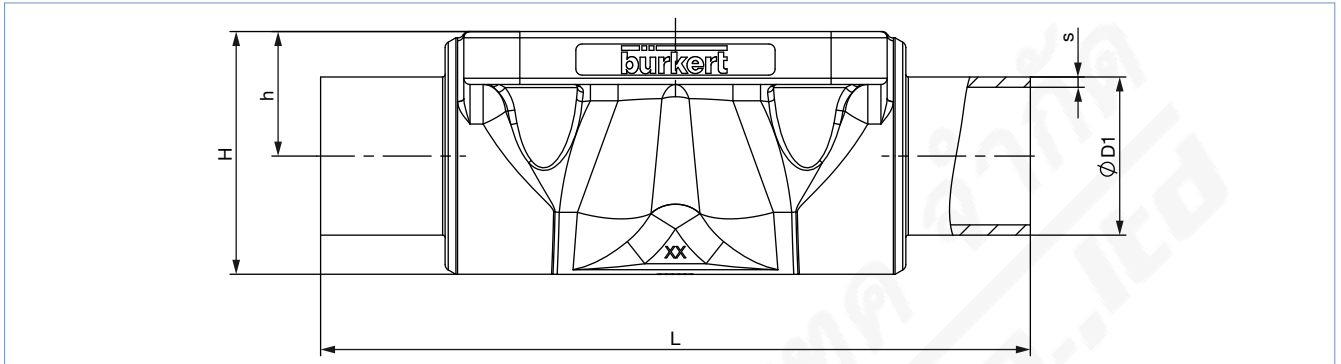

Diaphragm size	Port connection DN	ØD1	s	L	h	H	Product key ¹⁾
DIN EN ISO 1127 / ISO 4200 / DIN 11866 series B							
8	8	13.5	1.6	90	9.6	18.5	SA40
8	10	17.2	1.6	90	9.6	18.6	SA41
15	15	21.3	1.6	110	13.5	25.0	SA42
20	15	21.3	1.6	119	18.0	32.9	SA42
20	20	26.9	1.6	119	18.0	32.7	SA43
25	25	33.7	2.0	129	20.0	39.0	SA44
40	32	42.4	2.0	161	28.6	55.0	SA45
40	40	48.3	2.0	161	28.6	55.0	SA46
50	50	60.3	2.0	192	35.5	68.0	SA47
65	65	76.1	2.0	192	43.0	82.0	SA48
80	80	76.1	2.0	250	51.0	101.0	SA48
80	80	88.9	2.3	250	51.0	101.0	SA49
100	100	114.3	2.3	295	63.5	123.5	SA39
DIN 11850-2 / DIN 11866 series A / DIN EN 10357 series A							
8	10	13	1.5	90	9.6	18.6	SD40
15	15	19	1.5	110	13.5	25.0	SD42
20	20	23	1.5	119	18.0	32.8	SD43
25	25	29	1.5	129	20.0	39.0	SD44
40	40	41	1.5	161	28.6	55.0	SD46
50	50	53	1.5	192	35.5	68.0	SD47
65	65	70	2.0	192	43.0	82.0	SD48
80	80	85	2.0	250	51.0	101.0	SD49
100	100	104	2.0	295	63.5	123.5	SD50
ASME BPE / DIN 11866 series C							
8	¼"	6.35	0.89	64.5	9.6	18.6	SA90
8	⅜"	9.53	0.89	89	9.6	18.6	SA91
8	½"	12.7	1.65	89	9.6	18.6	SA92
15	¾"	19.05	1.65	102	13.5	25.0	SA93
20	¾"	19.05	1.65	119	18.0	32.8	SA93
20	1"	25.4	1.65	119	18.0	32.7	SODF
25	1"	25.4	1.65	114	20.0	39.0	SODF
40	1½"	38.1	1.65	140	28.6	55.0	SODH
50	2"	50.8	1.65	159	35.5	68.0	SODI
50	2½"	63.5	1.65	192	35.5	68.0	SODJ
65	2½"	63.5	1.65	192	43.0	82.0	SODJ
80	3"	76.2	1.65	250	51.0	101.0	SODK
100	4"	101.6	2.11	295	63.5	123.5	SODL

DTS 1000303711 EN Version: P Status: RL (released | freigegeben | validé) printed: 19.06.2024

Diaphragm size	Port connection DN	ØD1	s	L	h	H	Product key ^{1.)}
BS 4825							
8	8	6.35	1.20	64.5	9.6	18.6	SODB
8	10	9.53	1.20	89	9.6	18.6	SODC
8	15	12.7	1.20	89	9.6	18.6	SODD
15	20	19.05	1.20	102	14.0	25.5	SODE
20	25	25.4	1.65	119	18.0	32.8	SODF
25	25	25.4	1.65	114	20.0	39.0	SODF
40	40	38.1	1.65	140	28.6	55.0	SODH
50	50	50.8	1.65	159	35.5	68.0	SODI
50	65	63.5	1.65	192	35.5	68.0	SODJ
65	65	63.5	1.65	192	43.0	82.0	SODJ
80	80	76.2	1.65	250	51.0	101.0	SODK
100	100	101.6	2.11	295	63.5	123.5	SODL
SMS 3008							
20	25	25	1.2	119	18.0	32.8	SA60
25	25	25	1.2	129	20.0	39.0	SA60
40	40	38	1.2	161	28.6	55.0	SA62
50	50	51	1.2	192	35.5	68.0	SA63
DIN 11850-0							
8	4	6	1.0	90	9.6	18.6	SC40
8	6	8	1.0	90	9.6	18.6	SC41
8	8	10	1.0	90	9.6	18.6	SC42
15	15	18	1.5	110	13.5	25.0	SC43
20	20	22	1.5	119	18.0	32.8	SC44
25	25	28	1.5	129	20.0	39.0	SC45
25	32	34	1.5	129	20.0	39.0	SC46
40	40	40	1.5	161	28.6	56.0	SC47
50	50	52	1.5	192	35.5	68.0	SC48

1.) This information is part of the product key (see "7.3. Bürkert Product Enquiry Form" on page 36).

4.9. Cast valve body (VG) with clamp connection

Note:

- Dimensions in mm, unless otherwise stated
- Further information on the draining angle can be found in the “Additional manual Type 2xxx 3xxx” on our website (see **operating instructions Type 3363** ▶).

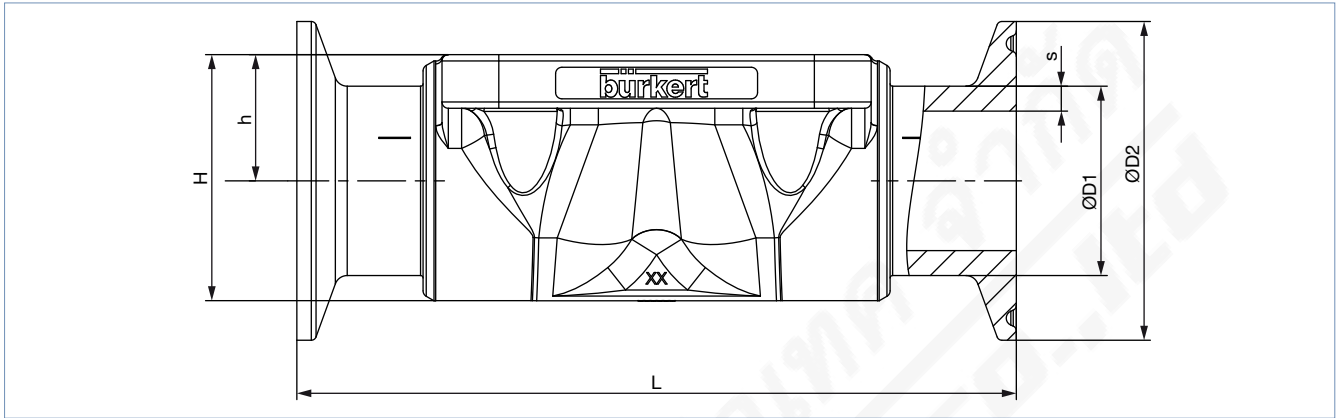

Diaphragm size	Port connection DN	ØD1	s	ØD2	L	h	H	Product key ^{1.)}
DIN 32676 series B (ISO pipe)								
25	25	33.7	2	50.5	129	20.0	39.0	TC44
40	40	48.3	2	64.0	161	28.6	55.0	TC46
50	50	60.3	2	77.5	192	35.5	68.0	TC47
DIN 32676 series A (DIN pipe)								
15	15	19	1.5	34.0	110	13.5	25.0	TD42
20	20	23	1.5	34.0	119	18.0	32.8	TD43
25	25	29	1.5	50.5	129	20.0	39.0	TD44
40	40	41	1.5	50.5	161	28.6	55.0	TD46
50	50	53	1.65	64.0	192	35.5	68.0	TD47
ASME BPE								
8	3/8"	9.53	0.89	25.0	89	9.6	18.6	TG01
8	1/2"	12.7	1.65	25.0	89	9.6	18.6	TG02
15	3/4"	19.05	1.65	25.0	102	13.5	23.0	TG03
20	3/4"	19.05	1.65	25.0	117	18.0	25.0	TG03
25	1"	25.4	1.65	50.5	114	18.0	40.0	TG04
40	1 1/2"	38.1	1.65	50.5	140	28.6	55.0	TG05
50	2"	50.8	1.65	64.0	159	35.5	68.0	TG06
50	2 1/2"	63.5	1.65	77.5	190	35.5	68.0	TG07
65	2 1/2"	63.5	1.65	77.5	249.2	43.0	82.0	TG07
80	3"	76.2	1.65	91	306.2	51.0	101.0	TG08
100	4"	101.6	2.11	119	352.2	63.5	123.5	TG09
BS 4825: Clamp BS 4825-3 / pipe BS 4825-1								
8	15	12.7	1.2	25	89	9.6	18.9	TH42
15	20	19.05	1.2	25	102	13.5	25.0	TH43
25	25	25.4	1.65	50.5	114	20.0	39.0	TG04
40	40	38.1	1.65	50.5	140	28.6	55.0	TG05
50	50	50.8	1.65	64.0	159	35.5	68.0	TG06
50	65	63.5	1.65	77.5	190	35.5	68.0	TG07
Clamp 34.0 similar to DIN 32676 series B (ISO pipe)								
15	15	21.3	1.6	34	110	13.5	25.0	TC42

1.) This information is part of the product key (see “7.3. Bürkert Product Enquiry Form” on page 36).

DTS 1000303711 EN Version: P Status: RL (released | freigegeben | valide) printed: 19.06.2024

4.10. Plastic body (PV, PD, PP) with spigot connections

Note:

Dimensions in mm, unless otherwise stated

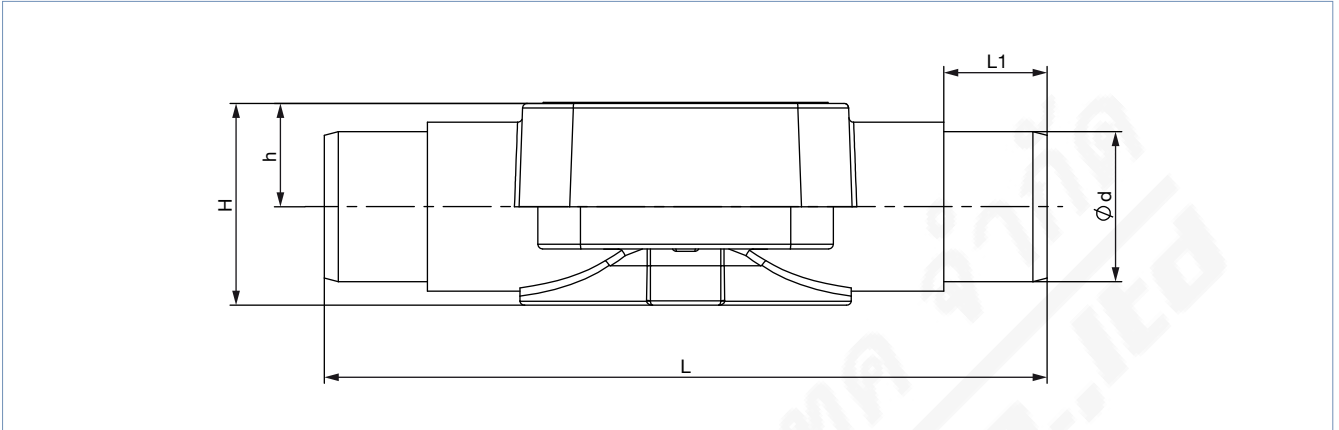

Diaphragm size	Ø d	Wall thickness	h	H	L	L1	Product key ^{1.)}
PVC-U (PV)							
15	20	2.5	15	29	124	16	KS25
20	25	2.5	18.5	36	144	19	KS26
25	32	3.5	22	43	154	22	KS27
32	40	4	27	52.5	174	26	KS28
40	50	5	33	65.5	194	31	KS29
50	63	6.5	40	79	224	44	KS30
PVDF (PD) and PP (PP)							
15	20	2.5	15	29	124	16	SS25
20	25	2.5	18.5	36	144	19	SS26
25	32	3.5	22	43	154	22	SS27
32	40	4	27	52.5	174	26	SS28
40	50	5	33	65.5	194	31	SS29
50	63	6.5	40	79	224	44	SS30

1.) This information is part of the product key (see "7.3. Bürkert Product Enquiry Form" on page 36).

4.11. Plastic body (PV, PD, PP) with true union

Note:

Dimensions in mm, unless otherwise stated

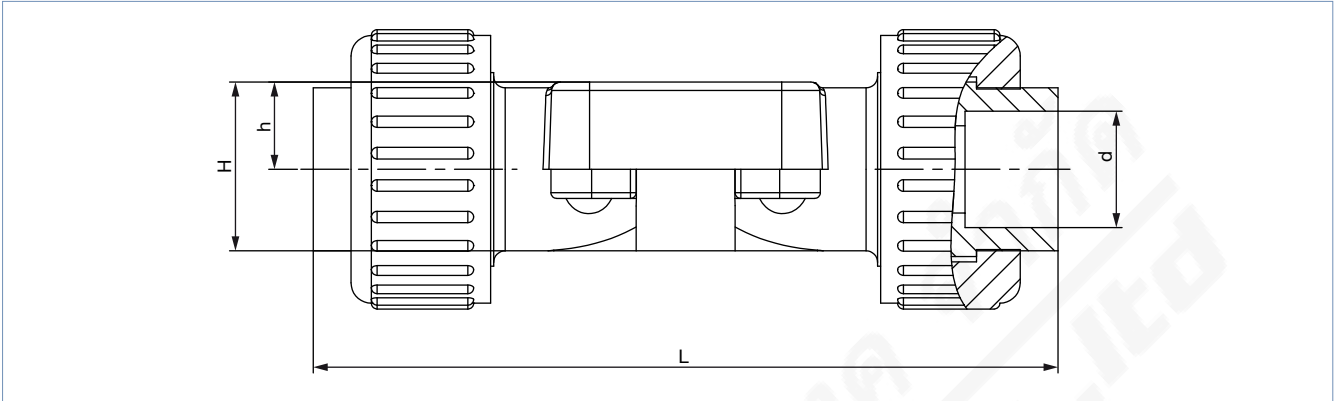

Diaphragm size	L	h	H	Ød	Product key ^{1.)}
PVC-U (PV)					
15	128	15	29	20	KM25
20	152	18.5	36	25	KM26
25	166	22	43	32	KM27
32	192	27	52.5	40	KM28
40	222	33	65.5	50	KM29
50	266	40	79	63	KM30
PVDF (PD)					
15	129	15	29	20	SM25
20	150	18.5	36	25	SM26
25	162	22	43	32	SM27
32	184	27	52.5	40	SM28
40	210	33	65.5	50	SM29
50	248	40	79	63	SM30
PP (PP)					
15	125	15	29	20	SM25
20	146	18.5	36	25	SM26
25	158	22	43	32	SM27
32	181	27	52.5	40	SM28
40	207	33	65.5	50	SM29
50	245	40	79	63	SM30

1.) This information is part of the product key (see "7.3. Bürkert Product Enquiry Form" on page 36).

4.12. Plastic body (PV, PD, PP) with flange connection

Note:

Dimensions in mm, unless otherwise stated

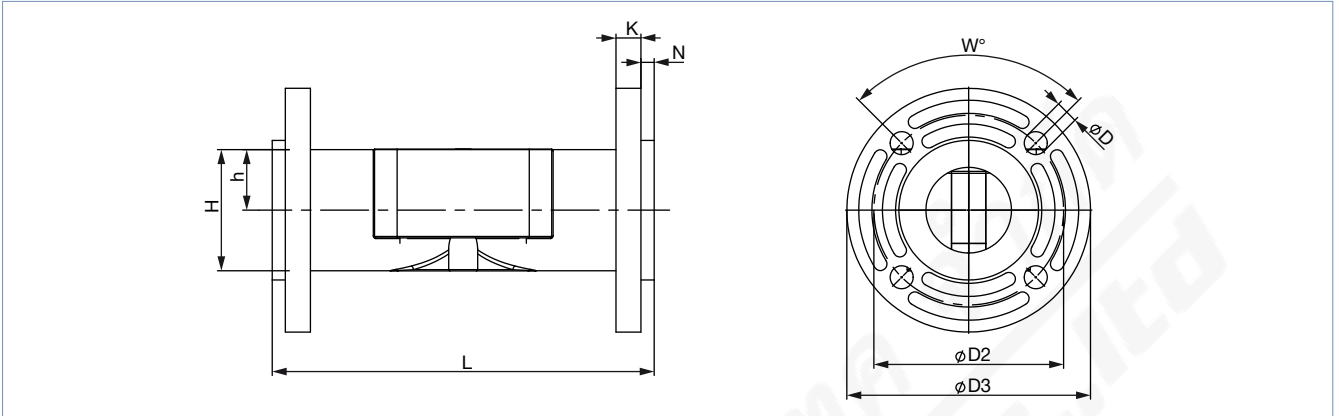

Diaphragm size	L	ØD2	ØD3	K	H	h	ØD	W	N	Product key ^{1.)}
PVC-U (PV), PVDF (PD) and PP (PP)										
15	130	65.5	96	12	-	-	14	4 x 90°	5.9	FL24
20	150	75	105	14	-	-	14	4 x 90°	6.9	FL25
25	160	85	115	15	-	-	14	4 x 90°	6.9	FL26
32	180	100	140	17	-	-	18	4 x 90°	7.9	FL27
40	200	110	150	17	-	-	18	4 x 90°	8	FL28
50	230	125	165	18	-	-	18	4 x 90°	9	FL29
65	290	145	185	19	92	47	18	4 x 90°	10	FL30
80	310	160	200	36	107	50	18	8 x 45°	-	FF31
100	350	180	225	35	134.5	65.5	18	8 x 45°	-	FF31

1.) This information is part of the product key (see "7.3. Bürkert Product Enquiry Form" on page 36).

DTS 1000303711 EN Version: P Status: RL (released | freigegeben | valide) printed: 19.06.2024



5. Performance specifications

5.1. Fluidic data

Flow characteristics

Note:

- The K_v values may vary slightly with different actuator sizes and diaphragm materials.
- More K_v values are available on request.
- Flow rate: K_v value water (m³/h) for elastomer diaphragm
- Measurement at +20 °C, 4 bar at valve inlet and 3 bar at valve outlet

Forged steel valve body (VS)

Diaphragm size DN	Port connection		K_v value water					
	[mm]	[inch]	DIN EN ISO 1127 / ISO 4200 / DIN 11866 series B [m ³ /h]	DIN 11850-2 / DIN 11866 series A / DIN EN 10357 series A [m ³ /h]	ASME BPE / DIN 11866 series C [m ³ /h]	DIN 11850-0 [m ³ /h]	BS4825 [m ³ /h]	SMS3008 [m ³ /h]
8	6	1/8"	–	–	–	1.1	–	–
8	8	1/4"	1.5	–	0.7	1.7	0.5	–
8	10	3/8"	1.5	1.5	1.6	–	1.4	–
8	15	1/2"	–	–	1.5	–	–	–
15	10	3/8"	5.5	3.5	–	–	–	–
15	15	1/2"	6.5	6.5	3.1	–	3.7	–
15	20	3/4"	–	–	6.5	–	–	–
20	20	3/4"	12.5	12.4	8.4	–	8.9	–
25	25	1"	18	20	15.5	–	15.5	16
40	32	1 1/4"	–	34	–	–	–	–
40	40	1 1/2"	41	40	37	–	37	38
50	50	2"	66	66	66	–	66	66
50	65	2 1/2"	–	–	70	–	70	70
65	65	2 1/2"	110	110	110	–	–	–
80	65	2 1/2"	–	150	–	–	–	–
80	80	3"	175	175	180	–	–	–
100	100	4"	235	240	235	–	–	–

Tube valve body (VP)

Diaphragm size DN	Port connection		K_v value water		
	[mm]	[inch]	DIN EN ISO 1127 / ISO 4200 / DIN 11866 series B [m ³ /h]	DIN 11850-2 / DIN 11866 series A / DIN EN 10357 series A [m ³ /h]	ASME BPE / DIN 11866 series C [m ³ /h]
8	8	1/4"	1.9	–	–
8	10	3/8"	–	1.9	–
8	15	1/2"	–	–	1.8
15	10	3/8"	–	–	7.1
15	15	1/2"	7.2	7.4	–
15	20	3/4"	–	7.4	–
20	20	3/4"	13.5	–	–
20	25	1"	–	14.9	12.8
25	32	1 1/4"	–	22.3	–
25	25	1"	20.8	–	–
32	40	1 1/2"	–	34.8	31
40	40	1 1/2"	47.9	–	–
40	50	2"	–	46.2	43
50	50	2"	60	–	60
65	80	3"	–	–	85
80	100	4"	–	–	145

DTS 1000303711 EN Version: P Status: RL (released | freigegeben | valide) printed: 19.06.2024

Cast valve body (VG)

Diaphragm size DN	Port connection		K _v value water [m ³ /h]
	[mm]	[inch]	
8	8	¼"	1
15	15	½"	5.6
20	20	¾"	10.7
25	25	1"	14.6
40	40	1½"	35
50	50	2"	47
65	65	2½"	65
80	80	3"	100
100	100	4"	180

Plastic body (PV, PD, PP)

Diaphragm size DN	Port connection		K _v value water [m ³ /h]
	[mm]	[inch]	
15	15	½"	3
20	20	¾"	7
25	25	1"	11.4
32	32	1¼"	17
40	40	1½"	24.5
50	50	2"	41.5
65	65	2½"	60
80	80	3"	100
100	100	4"	150

5.2. Operating limits

Medium pressure

Diaphragm size DN	Maximum operating pressure for seal material		
	EPDM, FKM [bar]	PTFE/EPDM, Advanced PTFE/EPDM (EU) [bar]	Laminate of GYLON® and EPDM (ER) [bar]
8	10	10	10
15	10	10	10
20	10	10	10
25	10	10	10
32	8	5.5	5.5
40	10	10	10
50	10	10	10
65	10	6	6
80	6	2.5	6
100	3.5	–	–

Operating limits for ambient and medium temperature

The maximum permissible temperature for the environment and the medium depend on each other. The maximum allowable temperature curves of different device variants are shown in the temperature chart.

Temperature diagram AG2

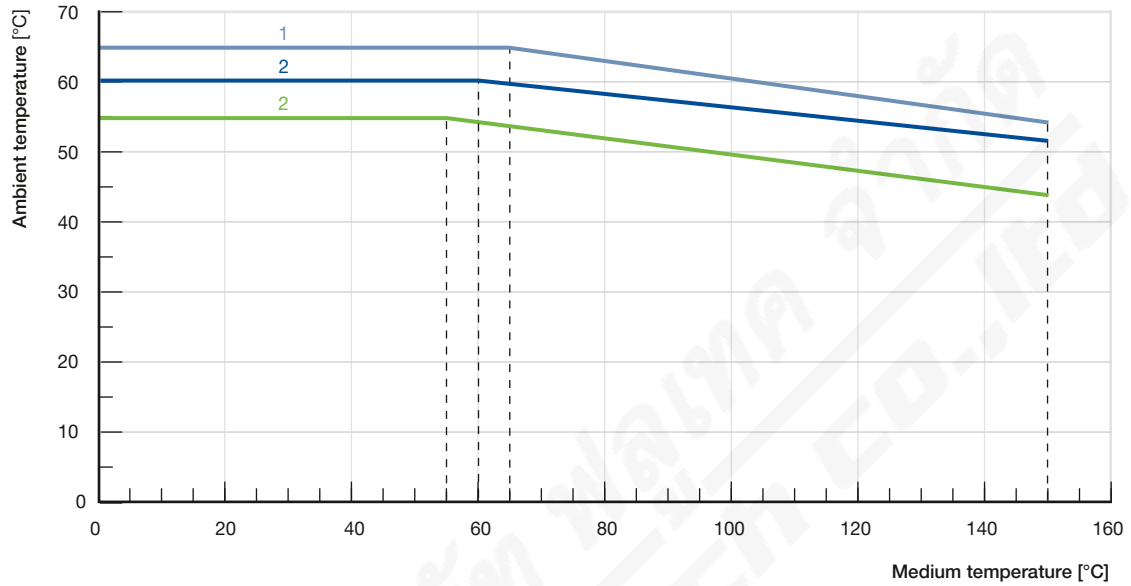

No.	Description
1	Devices without module
2	Devices with display
3	Devices with energy storage SAFEPOS energy-pack or fieldbus gateway, with/without display module

1.) The service life of the energy storage SAFEPOS energy-pack depends on the medium temperature and the ambient temperature.

DTS 1000303711 EN Version: P Status: RL (released | freigegeben | validé) printed: 19.06.2024

Temperature diagram AG3

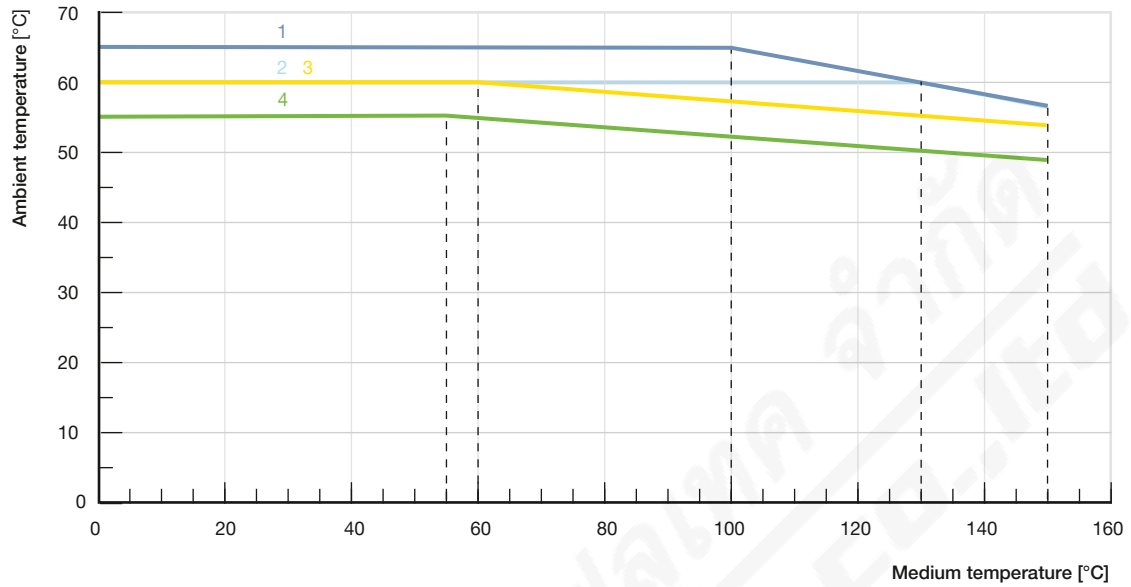

No.	Description
1	Devices without module
2	Devices with energy storage SAFEPOS energy-pack
3	Devices with display module with/without energy storage SAFEPOS energy-pack
4	Devices with fieldbus gateway with/without display module with/without energy storage SAFEPOS energy-pack

1.) The service life of the energy storage SAFEPOS energy-pack depends on the medium temperature and the ambient temperature.

5.3. Electrical control and interfaces

Interface diagram

The position of the actuator is regulated according to the position set-point value. The position set-point value is specified either by an external standard signal (analogue) or via a fieldbus (digital).

Analogue control

For analogue control, 2 variants are available for each the inputs and outputs and the connection interface.

Inputs and outputs:

- 1 analogue input, 1 binary input
- 1 analogue input, 1 binary input, 1 analogue output, 2 binary output (option)
- 1 input for actual process value (for process controller variant)

Interface:

- Cable gland with connection terminal (only AG2)
- M12 circular plug-in connectors (optional)

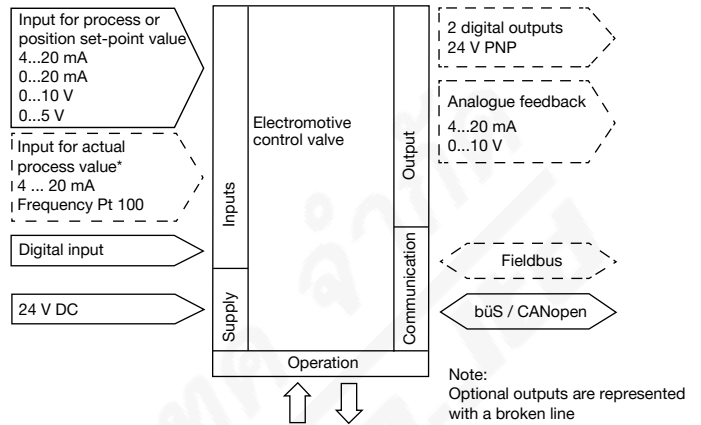

Control data	
Analogue input set-point value	Galvanically isolated from the supply voltage and analogue output 0/4...20 mA (input resistance 70 Ω) 0...5/10 V (input resistance 22 kΩ)
Analogue output	Maximum current 10 mA (for voltage output 0...5/10 V) Load 0...800 Ω (for current output 0/4...20 mA)
Digital input	0...5 V = log "0", 10...30 V = log "1", inverted input reversed accordingly
Digital output	PNP, current limitation 100 mA
Analogue input actual value (optional)	
4...20 mA	Input resistance: 80 Ω Resolution: 12 bit
Frequency	Measuring range: up to 1000 Hz Input resistance: >30 kΩ Resolution: 0.1 % of measurement value Input signal: >300 mVss Signal form: sine, rectangle, triangle
Pt 100	Measuring range: -20 °C...+220 °C Resolution: 0.01 °C Measurement current: 1 mA
Communication	
Communication interface (bÜS)	Connection to PC via USB bÜS interface set
Communication software (bÜS)	Bürkert Communicator, see Type 8920 ▶

DTS 1000303711 EN Version: P Status: RL (released | freigegeben | validé) printed: 19.06.2024

6. Product design and assembly

6.1. Product features

Note

Further information can be found in the **operating instructions Type 3363** ▶.

User interface	
<p>Device without display module</p> <p>The basic functions are operated by 4 DIP switches and 2 push buttons. These are located under the blind cover which can be removed manually by turning. Through the bÜS service access, the device can also be configured in detail with the Bürkert communicator software.</p> <p>For this, the optional USB-bÜS interface kit is required (see "7.4. Ordering chart accessories" on page 37).</p>	<p style="text-align: right;">Blind cover dismantled</p> <p>1.) Non-functional in devices with display module. The display must be used for operation!</p>
<p>Device with display module</p> <p>The robust display module is easy to use, it configures and displays all the required functions. In addition to the start screen you can also switch to the configuration view and user-specified views as needed. All functions of the device without display module like bÜS service interface are available, too.</p>	
Actuation	
<p>Mechanical manual control</p> <p>The manual override for mechanical movement of the valve is located for AG2 under the blind cover or display module and for AG3 under the pressure compensation element. It ensures that the actuator can be operated even if the power supply fails.</p>	
<p>Electrical control via operating elements</p> <p>The electrical manual override for the procedure is carried out via two buttons under the blind cover.</p>	

DTS 1000303711 EN Version: P Status: RL (released | freigegeben | valide) printed: 19.06.2024

<p>Display elements</p>		
<p>Display 360° LED light ring A clearly visible 360° LED ring is attached to the blind cover or display module to indicate the device status, the valve end position and the operating status. The LED light ring lights up, blinks or flashes into one or changing colours, depending on the LED mode set.</p> <p>Mechanical position indicator: The mechanical position indicator shows the current valve position even if the supply voltage fails.</p>		
<p>Data transmission (optional)</p>		
<p>SIM card (optional) With the optionally available SIM card, device-specific values and user settings can be stored and quickly transferred to another device.</p>		
<p>büS service interface The büS service interface connects the device with the Bürkert Communicator software on a PC, laptop or smartphone. From there a configuration of the device or error diagnosis can be carried out.</p>		
<p>Safety position via energy storage (optional)</p>		
<p>The safety starting positions in case of power interruption is realised with the optional energy storage SAFEPOS energy-pack. The desired position is set via the menu. In addition to the end positions (open/closed), any desired intermediate position can be defined here. The energy storage has a lifespan of up to 10 years, depending on the operating conditions. The power of the energy storage is monitored and a warning is displayed to indicate its service life coming to an end. The storage device is designed as a plug-in module to facilitate replacement. Without energy storage, the valve remains in the last position it was in.</p> <p>The energy storage device is fully charged and ready for operation after a maximum of 120 seconds (depending on the operating conditions).</p> <p>The energy storage device cannot be retrofitted in the field.</p>	<p>AG2</p>	<p>AG3</p>

DTS 1000303711 EN Version: P Status: RL (released | freigegeben | valide) printed: 19.06.2024

Fieldbus: EtherNet/IP, PROFINET, Modbus TCP (optional)

The fieldbus gateway for EtherNet/IP, PROFINET and Modbus TCP is integrated in an additional module. It has 2 fieldbus connections with 4-pin M12 circular sockets. The interfaces for the fieldbus connection and the status LEDs are located under the gateway housing cover. If there is a need for it to be included in a network, the Ethernet configuration can be performed via the web server.

The gateway cannot be retrofitted in the field.

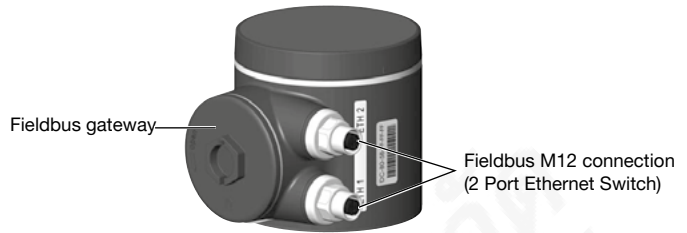

DTS 1000303711 EN Version: P Status: RL (released | freigegeben | valide) printed: 19.06.2024

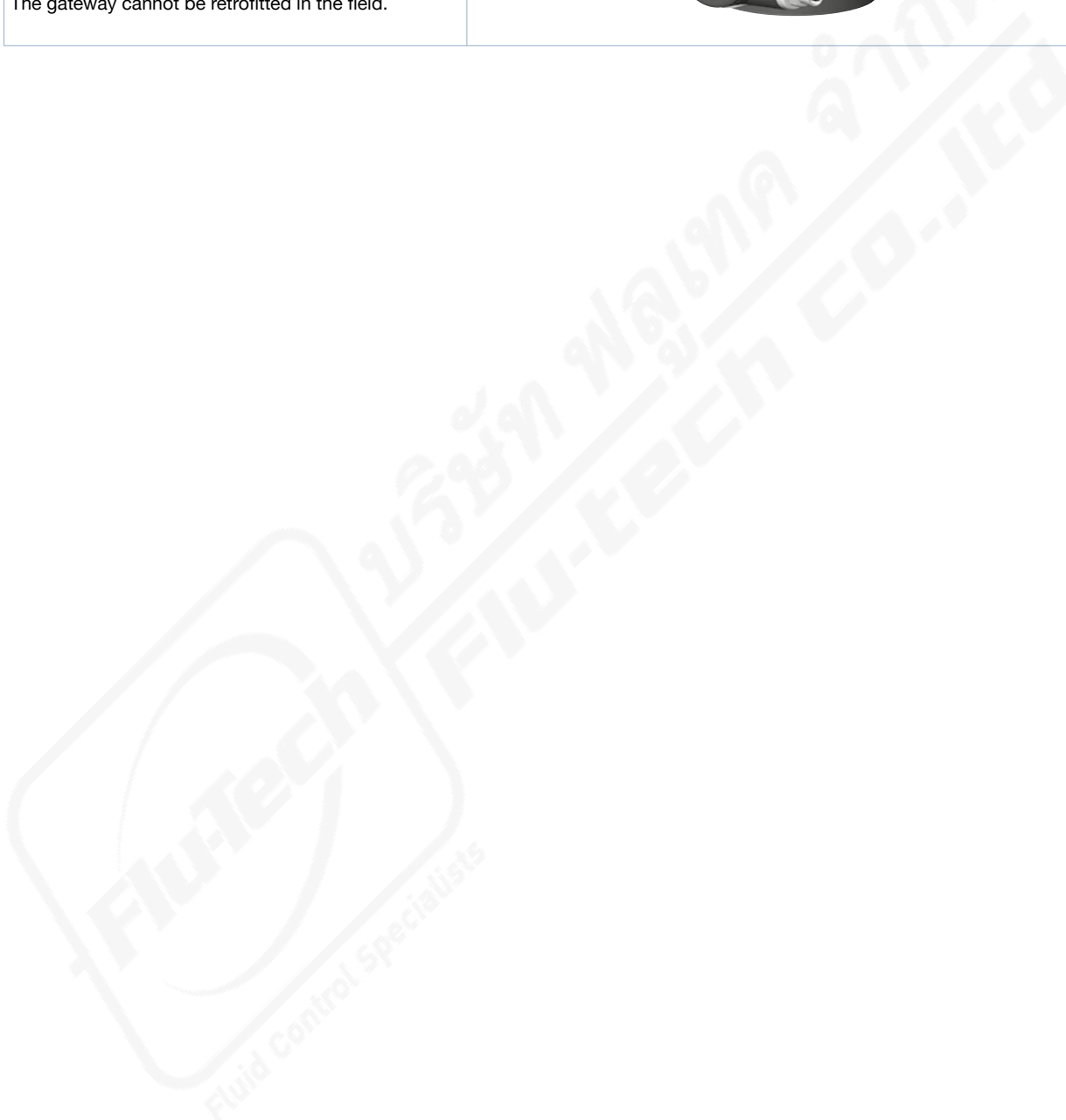

6.2. Product assembly

The electromotive linear drive consists of a brushless DC motor, a gear and a spindle system that transfers the force to the closing element. The integrated control electronics are controlled either by standard signals or via a fieldbus (digital). A positioner and a process controller are available as controller variants. The electromotive linear actuator is designed to provide optimum efficiency. At the same time, it keeps the valve tight and in position even at the maximum specified medium pressure in a powerless standstill. The optional energy storage device SAFEPOS energy-pack is available for the device. If the supply voltage fails, it supplies the actuator with the energy required to move the valve into the desired position which can be set in the menu.

The valve position can be changed manually in 2 ways. Either via the electrical manual control or via a mechanical manual control if no supply voltage is available. The device can be set and operated either via 2 capacitive keys and 4 DIP switches or optionally on a display with touch screen. Additionally, you can always operate the device via the bÜS service interface and using the software Bürkert Communicator.

The intelligent process valve Type 3363 offers the operator options for process monitoring, valve diagnosis and preventive maintenance. Internal measurements of the operating status are evaluated and, if necessary, issued as a warning or error message. These signal, for example, impermissible ambient and process conditions, functional deviations of components or the status of the energy storage device. A special feature of the globe control valve is the screwed-in valve seat which can be replaced to reduce the seat size.

To increase diaphragm service life, the drive force is adapted to the diaphragm size. It can also be adapted to the operating conditions to achieve optimum service life.

Structure of electromotive diaphragm valve Type 3363 AG2

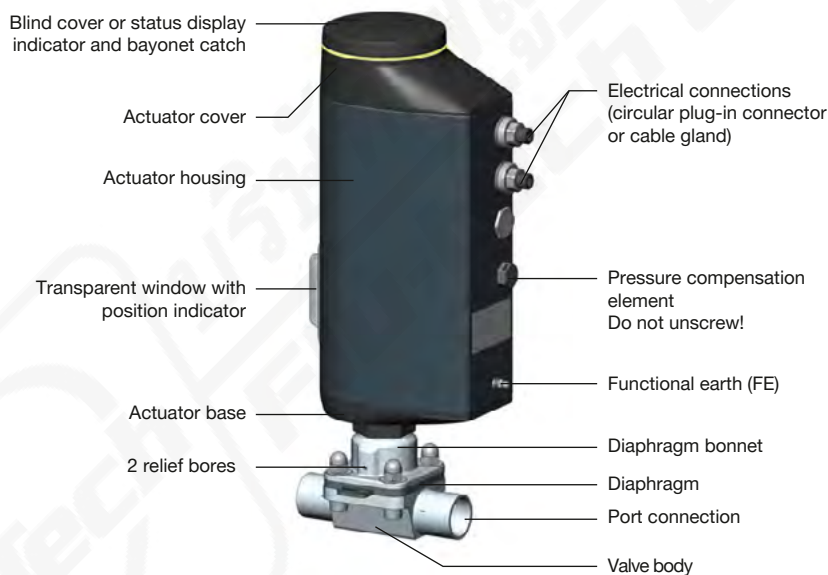

DTS 1000303711 EN Version: P Status: RL (released | freigegeben | valide) printed: 19.06.2024

Structure of electromotive diaphragm valve Type 3363 AG3

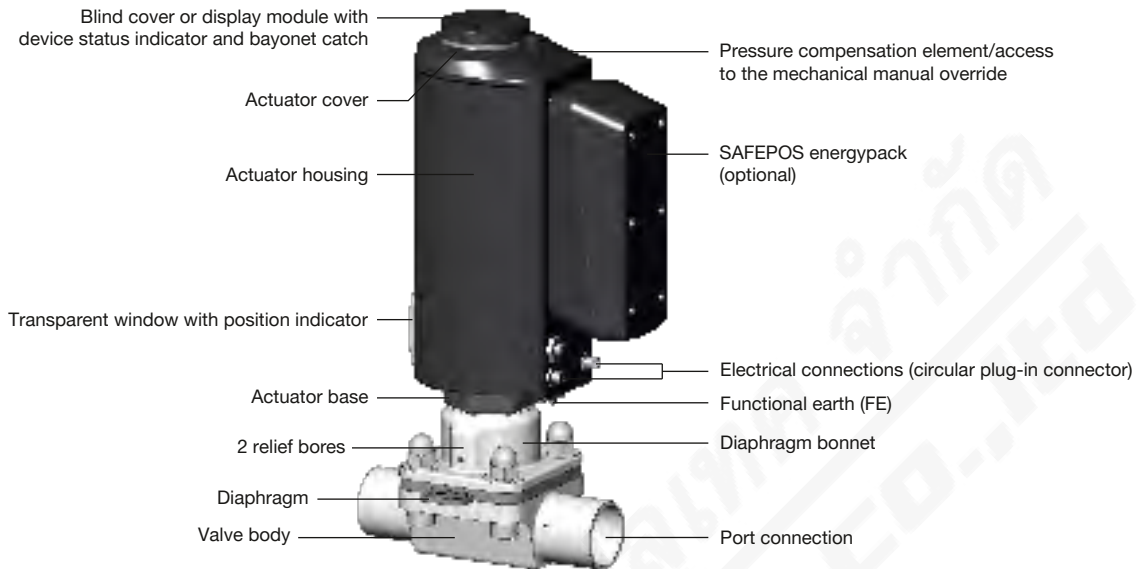

Integrated position controller	
<p>The position of the actuator (stroke) is controlled according to the position set-point. The position set-point is either given by an external standard signal (analogue) or via a fieldbus (digital). The displacement transducer records the actual position (POS) of the electric linear actuator. The positioner compares the actual position value with the position set-point (CMD) specified as standard signal. If there is a system deviation (Xd1), the electric motor drive is controlled via the actuating variable CTRL and the actual position value is changed accordingly.</p>	
Integrated process controller (optional)	
<p>The additionally implemented PID controller allows process control. The set-point position of the valve is calculated from the external signal (e.g. level, pressure, flow rate, temperature) for the process set-point and the actual process value via the control parameters (PID controller).</p>	

DTS 1000303711 EN Version: P Status: RL (released | freigegeben | validé) printed: 19.06.2024

7. Ordering information

7.1. Bürkert eShop



Bürkert eShop – Easy ordering and quick delivery

You want to find your desired Bürkert product or spare part quickly and order directly? Our online shop is available for you 24/7. Sign up and enjoy all the benefits.

[Order online now](#)

7.2. Bürkert product filter



Bürkert product filter – Get quickly to the right product

You want to select products comfortably based on your technical requirements? Use the Bürkert product filter and find suitable articles for your application quickly and easily.

[Try out our product filter](#)

7.3. Bürkert Product Enquiry Form

Note:

Please see our Product Enquiry Form for a full explanation of our specification key.

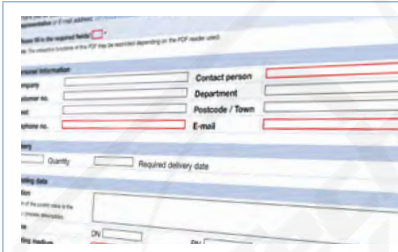

Bürkert Product Enquiry Form – Your enquiry quickly and compactly

Would you like to make a specific product enquiry based on your technical requirements? Use our Product Enquiry Form for this purpose. There you will find all the relevant information for your Bürkert contact. This will enable us to provide you with the best possible advice.

[Fill out the form now](#)

DTS 1000303711 EN Version: P Status: RL (released | freigegeben | validé) printed: 19.06.2024

7.4. Ordering chart accessories

Standard accessories

Description	Article no.
SIM card for data transmission between units	291773
Holding device for port connection DN 08...DN 40 ^{1.)}	697473
Dummy cover made of plastic	277881
Spare part energy storage SAFEPOS energy-pack (AG2)	285834
Spare part energy storage SAFEPOS energy-pack (AG3)	20046438

1.) For diaphragm size 08, the holding device is included in the scope of delivery.

Accessories cable

Note:

For connection to a bus/CANopen network see **cabling guide** ▶

Description	Article no.
M12 circular socket with cable, 4-pin, A-coded, cable length: 5 m, for X3, operating voltage AG2 (without communication)	918038
M12 circular socket with cable, 5-pin, L-coded, cable length: 5 m, for X4, operating voltage AG2 (without communication)	20010840
M12 circular socket with cable, 8-pin, A-coded, cable length: 2 m, for X1, input and output signals	919061
M12 circular plug with cable (shielded), 5-pin, A-coded, cable length: 2 m, for X2, input signals process actual value (only for variant with process controller)	559177

Bürkert accessories

Note:

- For connection to a bus/CANopen network see **cabling guide** ▶
- For detailed accessory tables see **cabling guide** ▶.

Description	Article no.
Software Bürkert Communicator, Type 8920	Type 8920 ▶
USB-bus-Interface Set 1 (Type 8923)	772426
USB-bus-Interface Set 2 (Type 8923)	772551
bus adapter for bus service interface (M12 on bus service interface micro USB), cable length: 0.3 mm	773254

DTS 1000303711 EN Version: P Status: RL (released | freigegeben | valide) printed: 19.06.2024