









## Explosion Proof Rotary Actuator - On/Off and control

- Direct mounting for quarter-turn valves
- Manual override
- Corrosion resistant
- Adjustable limit switches
- ATEX II 2 GD Ex d II B T6

Product variants described in the data sheet may differ from the product presentation and description.

### Can be combined with

	<b>Type 2651</b> 2/2 or 3/2-way Ball Valve, 2-Piece	▶
	<b>Type 2654</b> 2/2-way ball valve 3-piece	▶
	<b>Type 2657</b> Ball Valve, manually-operated	▶
	<b>Type 2671</b> Butterfly valve	▶
	<b>Type 2674</b> Plastic butterfly valve	▶
	<b>Type TKU001</b> 2/2-way compact flange ball valve	▶
	<b>Type 8804</b> Ball valve / butterfly valve with electrical rotary actuator	▶

### Type description

The electrical rotary actuator type 3004 is a compact, powerful and explosion proofed actuator system which provides a long service life. Materials and components have been chosen for a maintenance-free operation and ensure low thermal loading on the actuator. The modular design offers many options such as extra limit switches or potentiometers, to be added to the basic unit.



## Table of contents

<b>1. General Technical Data</b>	<b>3</b>
<b>2. Materials</b>	<b>4</b>
2.1. Chemical Resistance Chart – Bürkert resistApp.....	4
<b>3. Dimensions</b>	<b>4</b>
3.1. Motor 25, 45, 75 Nm.....	4
3.2. Motor 100, 150, 300 Nm.....	5
<b>4. Device/Process connections</b>	<b>6</b>
4.1. Multi-voltage or 24 V AC/DC standard version.....	6
4.2. Multi-voltage or 24 V AC/DC with programmable analogue signal input or output.....	7
<b>5. Product design and assembly</b>	<b>8</b>
5.1. Product features.....	8
<b>6. Ordering information</b>	<b>9</b>
6.1. Bürkert eShop – Easy ordering and quick delivery.....	9
6.2. Bürkert product filter.....	9
6.3. Ordering chart.....	9
Standard version without analogue signal input.....	9
Control version with 4...20 mA, 0...20 mA or 0...10 V programmable analogue signal input or output.....	10
6.4. Ordering chart accessories.....	10
Conversion sleeves.....	10
Spare battery for actuators with electronic emergency reset.....	11
Other accessories.....	11

## 1. General Technical Data

Product properties	
Dimensions	Detailed information can be found in chapter "3. Dimensions" on page 4.
<b>Material</b>	
Cover / Body	Epoxy coated aluminium
Axis / Screw	Stainless steel
Gear	Stainless steel
<b>ISO Mounting</b>	
Motor 25, 45, 75 Nm	F05/F07
Motor 100, 150, 300 Nm	F07/F10
<b>Drive</b>	
Motor 25 Nm	Female star 17 mm; conversion sleeve star 17/11 mm enclosed
Motor 45, 75 Nm	Female star 17 mm; conversion sleeve star 17/14 mm enclosed
Motor 100, 150, 300 Nm	Female star 22 mm; conversion sleeve star 22/17 mm enclosed
<b>Manual override</b>	
Motor 25, 45, 75 Nm	By outgoing axis with return spring
Motor 100, 150, 300 Nm	By hand wheel
<b>Weight</b>	
Motor 25, 45, 75 Nm	4 kg
Motor 100, 150, 300 Nm	6 kg
Mechanical limit stops	Standard
Optical position indicator	Standard
Performance data	
Torque	25, 45, 75, 100, 150 und 300 Nm Detailed information can be found in chapter "6. Ordering information" on page 9.
Position angle	90° (±5°)
Actuating time (10...90 %)	7...50 sec. Detailed information can be found in chapter "6. Ordering information" on page 9.
Options	Rotation 180° or 270° 3 position actuator (for 180°) Feedback On/Off actuators: - Potentiometer 1K, 5K, or 10K - Analogue signal 4...20 mA Fail safe option* (on request) 2 extra limit switches
Electrical data	
Operating voltage	100...240 V AC / 50...60 Hz oder 24 V AC/DC ± 10 %
Limit switches	4 adjustable (2 for motor and 2 additional for feedback) max. 250 V AC/5 A
Power consumption	45 W...85 W
Voltage tolerance	± 10 %
Analogue signals control version	
Input	-0...10 V / -4...20 mA / -0...20 mA
Output	-0...10 V / -4...20 mA / -0...20 mA
Motor protection	Electronic torque limited
Duty cycle	At max. torque: 50 % of the time Control actuator: 50 % of max. torque
Heating resistor	10 W
Process/Port connection & communication	
Electrical connection	2 cable glands ISO 20
Environment and installation	
Installation position	Do not mount the actuator upside down!
Ambient temperature	-20 °C...+70 °C
Degree of protection	IP68

## 2. Materials

### 2.1. Chemical Resistance Chart – Bürkert resistApp

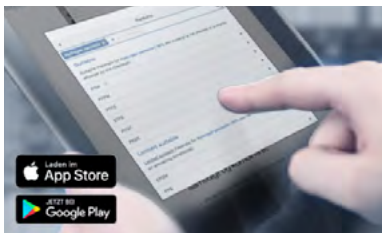

**Bürkert resistApp – Chemical Resistance Chart**

You want to ensure the reliability and durability of the materials in your individual application case? Verify your combination of media and materials on our website or in our resistApp.

Start Chemical Resistance Check

## 3. Dimensions

### 3.1. Motor 25, 45, 75 Nm

**Note:**  
Dimensions in mm

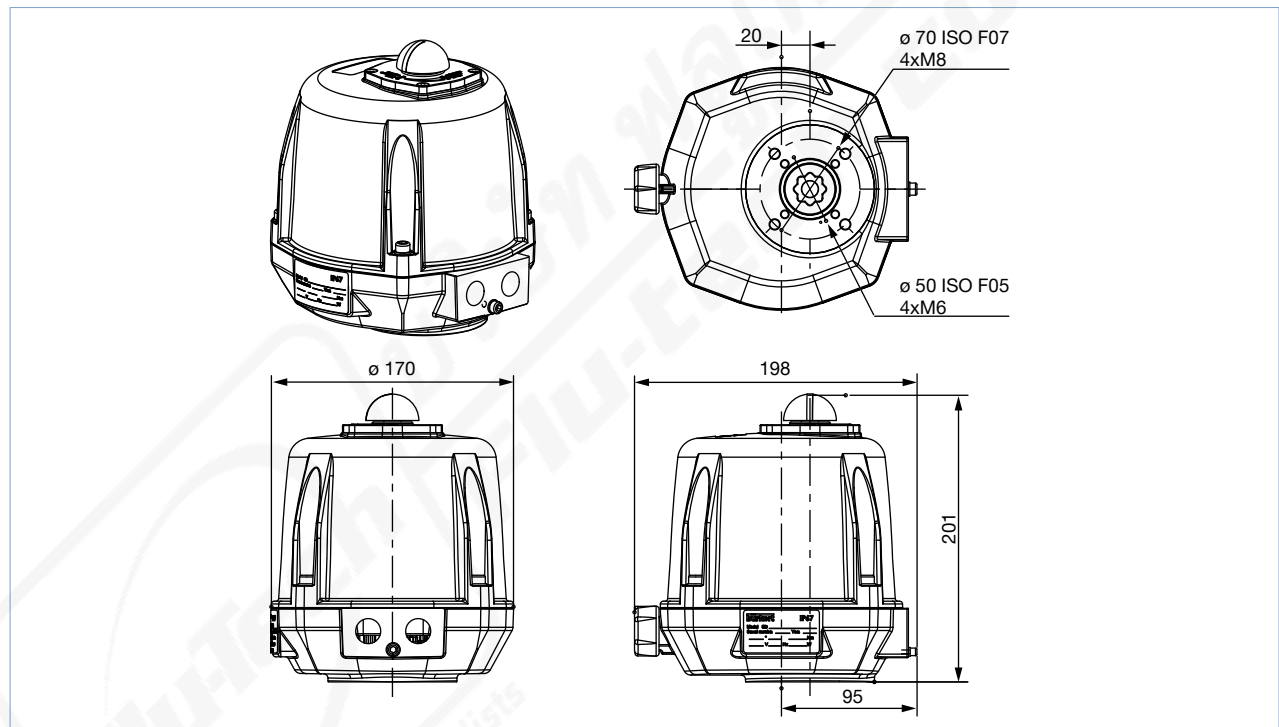

DTS 1000097022 EN Version: V Status: RL (released | freigegeben | valide) printed: 22.02.2023

3.2. Motor 100, 150, 300 Nm

Note:

Dimensions in mm

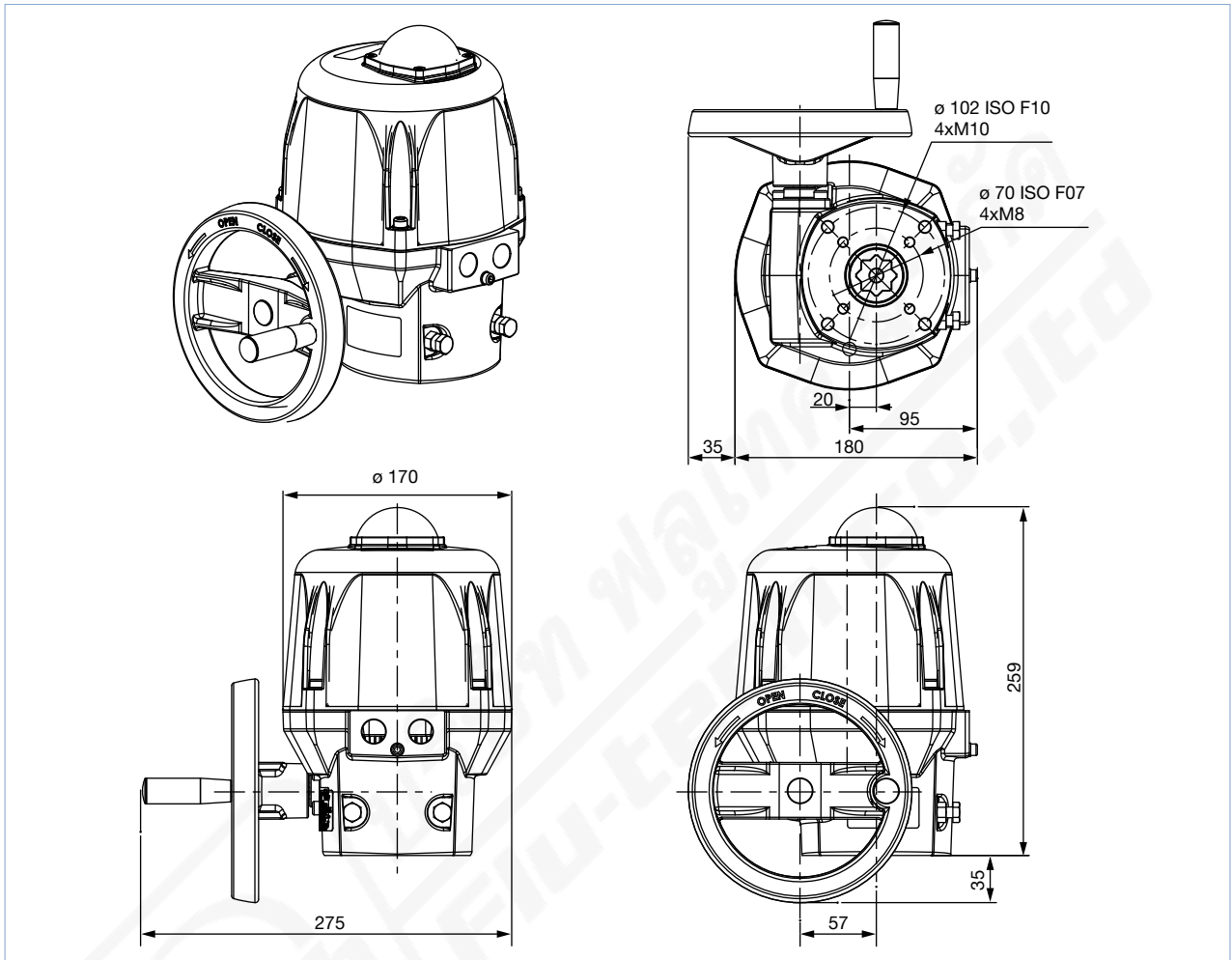

DTS 1000097022 EN Version: V Status: RL (released | freigegeben | validé) printed: 22.02.2023

### 4. Device/Process connections

#### 4.1. Multi-voltage or 24 V AC/DC standard version

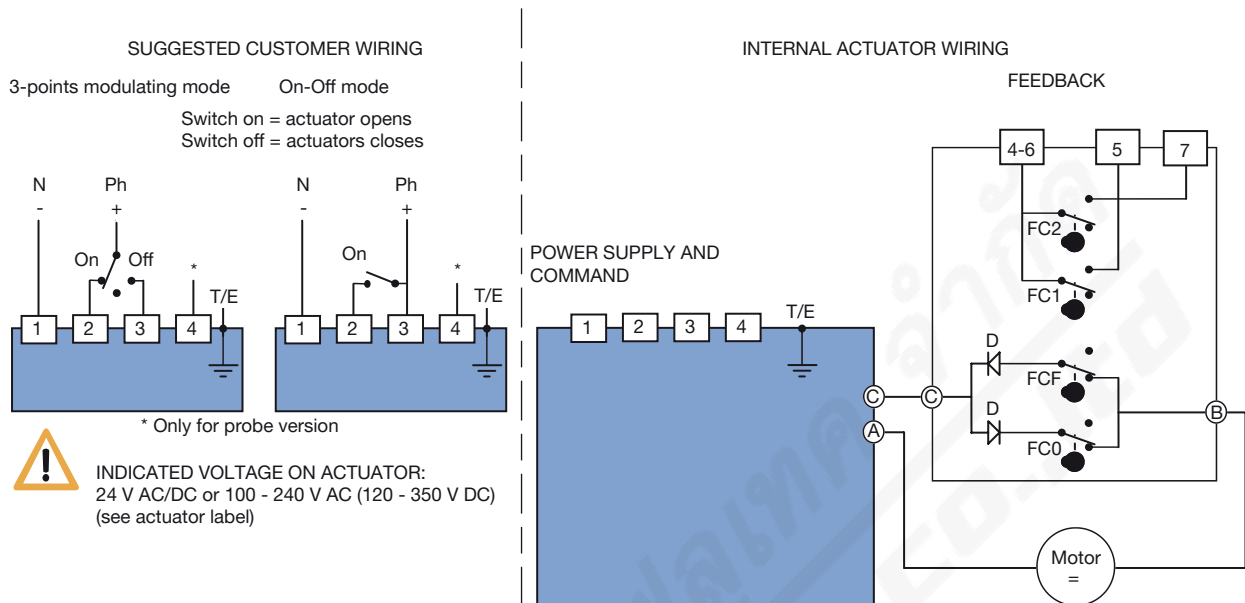

Symbol	Description
<b>FCO</b>	Open limit switch
<b>FCF</b>	Close limit switch
<b>FC1</b>	Auxiliary 1 limit switch
<b>FC2</b>	Auxiliary 2 limit switch

DTS 1000097022 EN Version: V Status: RL (released | freigegeben | valide) printed: 22.02.2023

4.2. Multi-voltage or 24 V AC/DC with programmable analogue signal input or output

POWER SUPPLY:

100 - 240 V AC (120 - 350 V DC)

\* Only for probe version

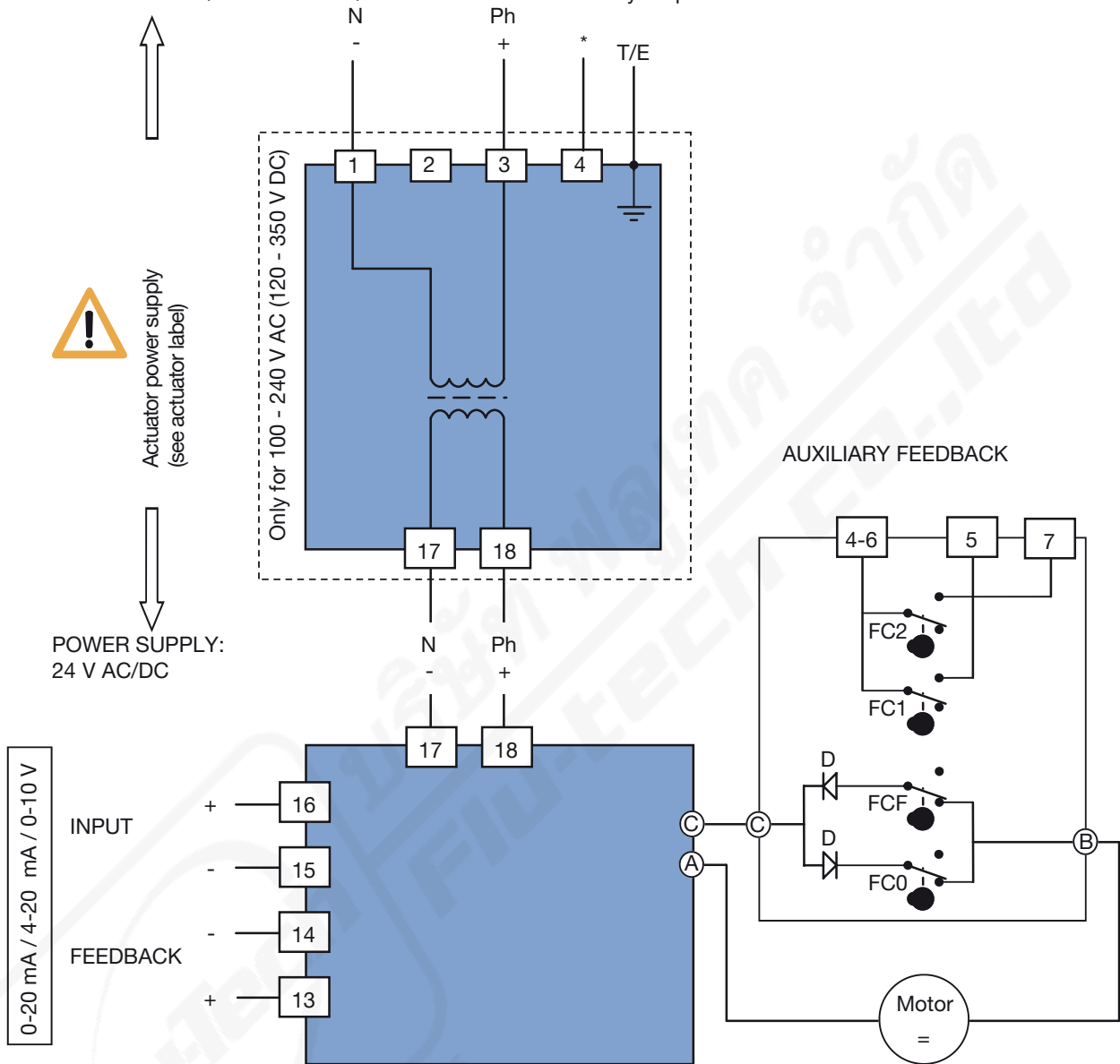

Symbol	Description
FC0	Open limit switch
FCF	Close limit switch
FC1	Auxiliary 1 limit switch
FC2	Auxiliary 2 limit switch

DTS 1000097022 EN Version: V Status: RL (released | freigegeben | validé) printed: 22.02.2023



## 5. Product design and assembly

### 5.1. Product features

Motor 25, 45, 75 Nm

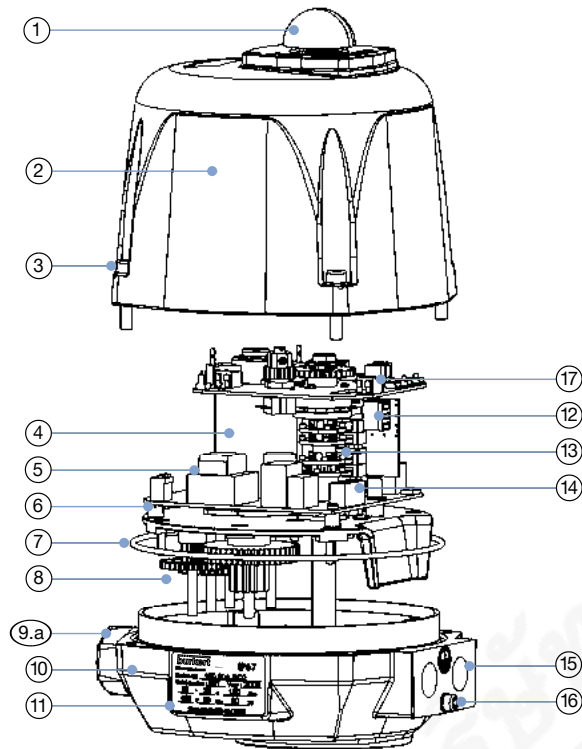

Motor 100, 150, 300 Nm

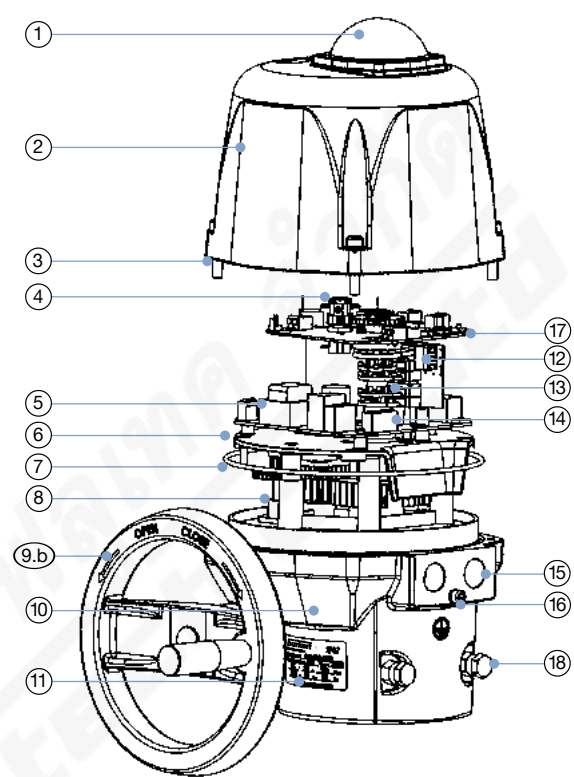

No.	Element
1	Optical position indicator
2	Cover
3	Stainless steel screws
4	Motor
5	Power supply card
6	Gear box
7	O-ring
8	Gear
9.a	Manual override
9.b	Hand wheel
10	Housing
11	Identification label
12	Auxiliary limit switch terminal
13	Cams
14	Power supply terminal
15	Internal thread M20 × 1.5
16	Earth screw
17	Positioning card (only actuator with position control)
18	Mechanical limit stops

DTS 1000097022 EN Version: V Status: RL (released | freigegeben | valide) printed: 22.02.2023



## 6. Ordering information

### 6.1. Bürkert eShop – Easy ordering and quick delivery



**Bürkert eShop – Easy ordering and fast delivery**

You want to find your desired Bürkert product or spare part quickly and order directly? Our online shop is available for you 24/7. Sign up and enjoy all the benefits.

[Order online now](#)

### 6.2. Bürkert product filter



**Bürkert product filter – Get quickly to the right product**

You want to select products comfortably based on your technical requirements? Use the Bürkert product filter and find suitable articles for your application quickly and easily.

[Try out our product filter](#)

### 6.3. Ordering chart

#### Standard version without analogue signal input

**Note:**

- For the actuator choice, we recommend a safety torque equal to 1.5 times of the valve maximal torque (2 times for the control version).
- Other regulating times and delay angles on request

Drive stars	Conversion adapter star	Connection flange	Torque	90° ravel	Power consumption	Voltage / Frequency	Article no.					
[mm]	[mm]		[Nm]	[s]	[W]	[V / Hz]						
17	17/11	F05-F07	25	7	45	100...240 V AC, / 50/60 Hz / 100...350 V DC	181308					
						15...30 V AC, 50/60 Hz / 12...48 V DC <sup>1.)</sup>	181309					
	17/14	F05-F07	45	15	45	100...240 V AC, / 50/60 Hz / 100...350 V DC	181310					
						15...30 V AC, 50/60 Hz / 12...48 V DC <sup>1.)</sup>	181311					
						100...240 V AC, / 50/60 Hz / 100...350 V DC	181312					
						15...30 V AC, 50/60 Hz / 12...48 V DC <sup>1.)</sup>	181313					
22	22/17	F07-F10	100	15	45	100...240 V AC, / 50/60 Hz / 100...350 V DC	181314					
						15...30 V AC, 50/60 Hz / 12...48 V DC <sup>1.)</sup>	181315					
			150	30	45	30	45	100...240 V AC, / 50/60 Hz / 100...350 V DC	181316			
								15...30 V AC, 50/60 Hz / 12...48 V DC <sup>1.)</sup>	181317			
								300	60	45	100...240 V AC, / 50/60 Hz / 100...350 V DC	181318
											15...30 V AC, 50/60 Hz / 12...48 V DC <sup>1.)</sup>	181319

1.) The operating voltage mustn't to fall below 11.5 V

Control version with 4...20 mA, 0...20 mA or 0...10 V programmable analogue signal input or output

Note:

- For the actuator choice, we recommend a safety torque equal to 1.5 times of the valve maximal torque (2 times for the control version).
- Other regulating times and delay angles on request

Drive stars	Conversion adapter star	Connection flange	Torque	90° ravel	Power consumption	Voltage / Frequency	Article no.
[mm]	[mm]		[Nm]	[s]	[W]	[V / Hz]	
17	17/11	F05-F07	25	15	45	100...240 V AC, / 50/60 Hz / 100...350 V DC	182324
						15...30 V AC, 50/60 Hz / 12...48 V DC <sup>1.)</sup>	182326
	17/14	F05-F07	45	15	45	100...240 V AC, / 50/60 Hz / 100...350 V DC	182327
						15...30 V AC, 50/60 Hz / 12...48 V DC <sup>1.)</sup>	182330
						100...240 V AC, / 50/60 Hz / 100...350 V DC	182335
						15...30 V AC, 50/60 Hz / 12...48 V DC <sup>1.)</sup>	182384
22	22/17	F07-F10	100	15	45	100...240 V AC, / 50/60 Hz / 100...350 V DC	182385
						15...30 V AC, 50/60 Hz / 12...48 V DC <sup>1.)</sup>	182386
	150	30	45	30	45	100...240 V AC, / 50/60 Hz / 100...350 V DC	182388
						15...30 V AC, 50/60 Hz / 12...48 V DC <sup>1.)</sup>	182390
						100...240 V AC, / 50/60 Hz / 100...350 V DC	182392
						15...30 V AC, 50/60 Hz / 12...48 V DC <sup>1.)</sup>	182394

1.) The operating voltage mustn't to fall below 11.5 V

**Further versions on request**

**Voltage**

Other voltages



### 6.4. Ordering chart accessories

#### Conversion sleeves

Description	Article no.
Conversion Sleeve star/square 14/9 mm	665288
Conversion Sleeve star/square 14/11 mm	665289
Conversion Sleeve square/square 17/14 mm	665290
Conversion Sleeve star/square 17/14 mm	773348
Conversion Sleeve star/square 17/11 mm	773343
Conversion Sleeve square/square 22/19 mm	773836
Conversion Sleeve star/square 22/17 mm	684858
Conversion Sleeve star/star 22/14 mm	666684
Conversion Sleeve star/square 22/11 mm	773344
Conversion Sleeve star/square 27/22 mm	774594
Conversion Sleeve square/square 27/19 mm	774279
Conversion Sleeve square/square 27/17 mm	774193

**Spare battery for actuators with electronic emergency reset****Note:**

- The battery must be replaced after max. 500 charging cycles or after 2 years at the latest. Depending on which condition is reached earlier.
- Additional information for Type 3004: The person who changes the battery must be trained and qualified to do modifications on ATEX products.
- Actuators that do not have an electronic emergency reset when delivered cannot be upgraded with this device at a later date.

Type	Version	Torque [Nm]	Article no.
3003	BB40	10...100	775335 
3004/5	BB40	25...300	774761 
3004/5	BB40	600...2400	775337 

**Other accessories**

Description	Article no.
Key for adjusting the limit switches	679946 