





Cable plug for whisper valve Types 6712 and 6724

- Latching
- Stranded wire version available
- Boost Close and Soft Close electronics assembly
- Impuls-Elektronik



Product variants described in the data sheet may differ from the product presentation and description.

Can be combined with

	Type 6712 2/2-way Whisper Valve with media separation	▶
	Type 6724 2/2 or 3/2-way Whisper Valve with media separation	▶

Type description

Plug connection with locking lugs for contacting Bürkert whisper valves. This robust and affordable plug connection has become well established for Bürkert whisper valves Types 6712 and 6724 in the fields of analysis technology. In addition to the stranded wire versions, versions with electronics assembly are also available that actively influence the switching behaviour of the valve and thus fully exploit the potential of the whisper valve actuator.



Table of contents

1. General technical data	3
2. Product versions	3
3. Dimensions	4
3.1. Connector without PCB.....	4
3.2. Connector for PCB mounting.....	5
3.3. Connector with PCB.....	5
4. Ordering information	6
4.1. Bürkert eShop – Easy ordering and quick delivery.....	6
4.2. Bürkert product filter.....	6
4.3. Ordering chart.....	7
Connector without PCB.....	7
Connector with PCB “Boost Close”.....	7
Connector with PCB “Soft Close”.....	8
Connector with PCB “Impulse”.....	8

1. General technical data

Product properties	
Dimensions	Detailed information can be found in chapter "3. Dimensions" on page 4.
Material	
Connector housing	Polyamide
Plug contacts	Bronze gold-plated
Flying leads (insulation)	PVC
Cable outlet	Straight
Flying leads cross section	0.22 mm ² corresponds to AWG 24
Number of pins	2 pin
Electrical data	
Maximum continuous current	
Without PCB	2 A
With PCB	0.2 A
Nominal voltage	Up to 24 V DC
Contact resistance	≤ 10 mΩ
Environment and installation	
Ambient temperature without PCB	0 °C...+70 °C
Ambient temperature with PCB	0 °C...+60 °C
Protection class	IP10
Minimum bending radius	Single bending: 6 mm radius Multiple bending: 12 mm radius

2. Product versions

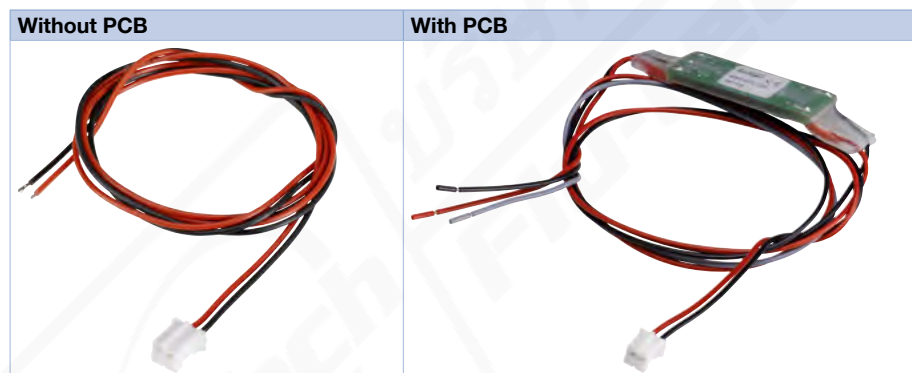

3. Dimensions

3.1. Connector without PCB

Note:

- Dimensions in mm
- On request, different flying lead lengths available
- On request, flying lead ends can be individually assembled for customer adaptation

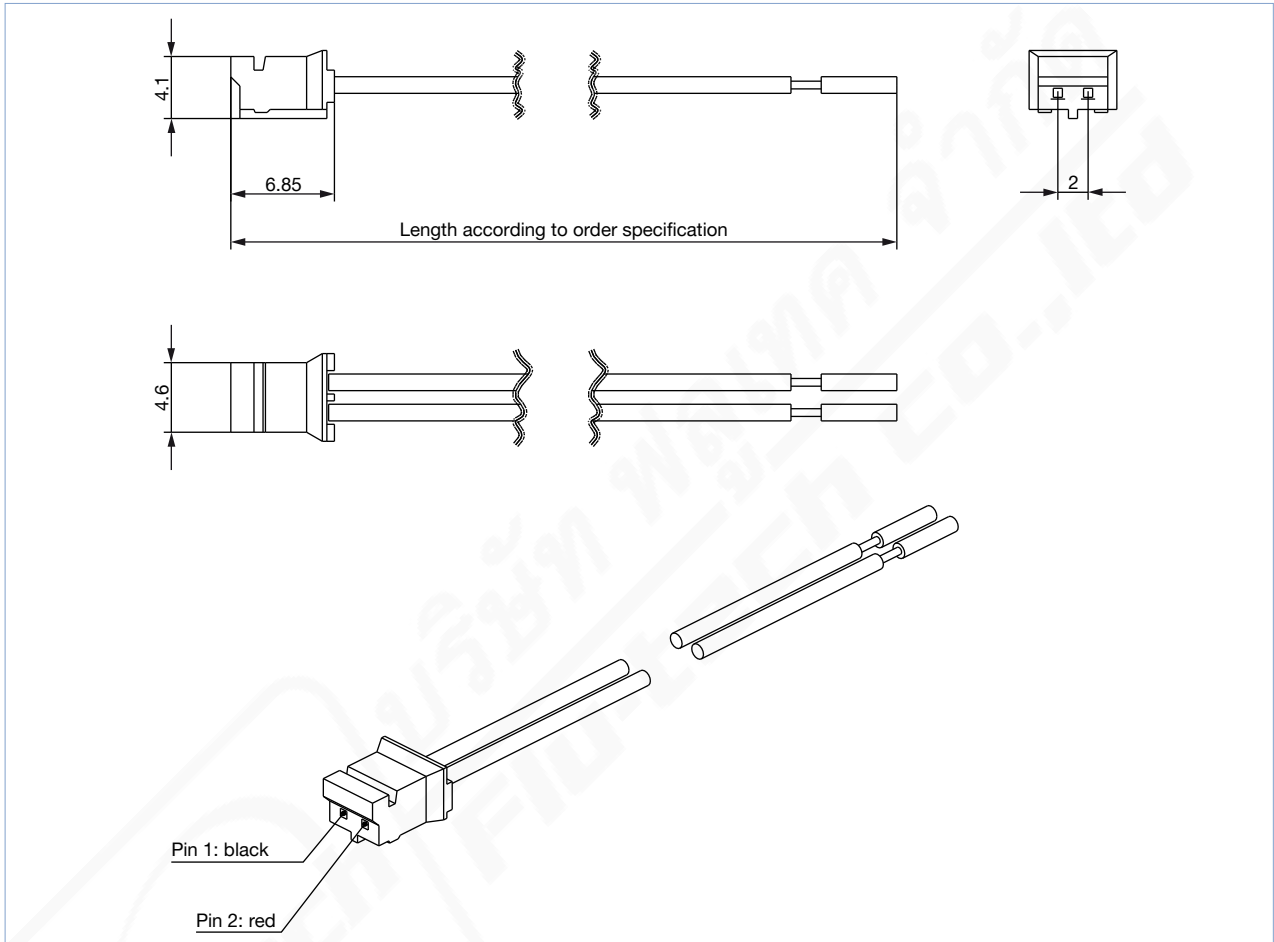

Description	Flying leads length	Article no.
	Connector^{1.)} with flying leads AWG 24	
	500 mm	689974
	1000 mm	349986
	2000 mm	318330

1.) Plug connector comparable to e.g.: W+P: 521 series (socket 521-02-1; contact 521-01-2-00) or JST (socket PHR-2; contact SPH-002GW-P0, 5S), as of 04/2015).

3.2. Connector for PCB mounting

Note:

- Dimensions in mm
- E.g. Samtec SQT-102-01-x-S (x=L or F), W+P series 257 art. no. 257-002-1-50-00-6
- The connectors are not available from Bürkert.

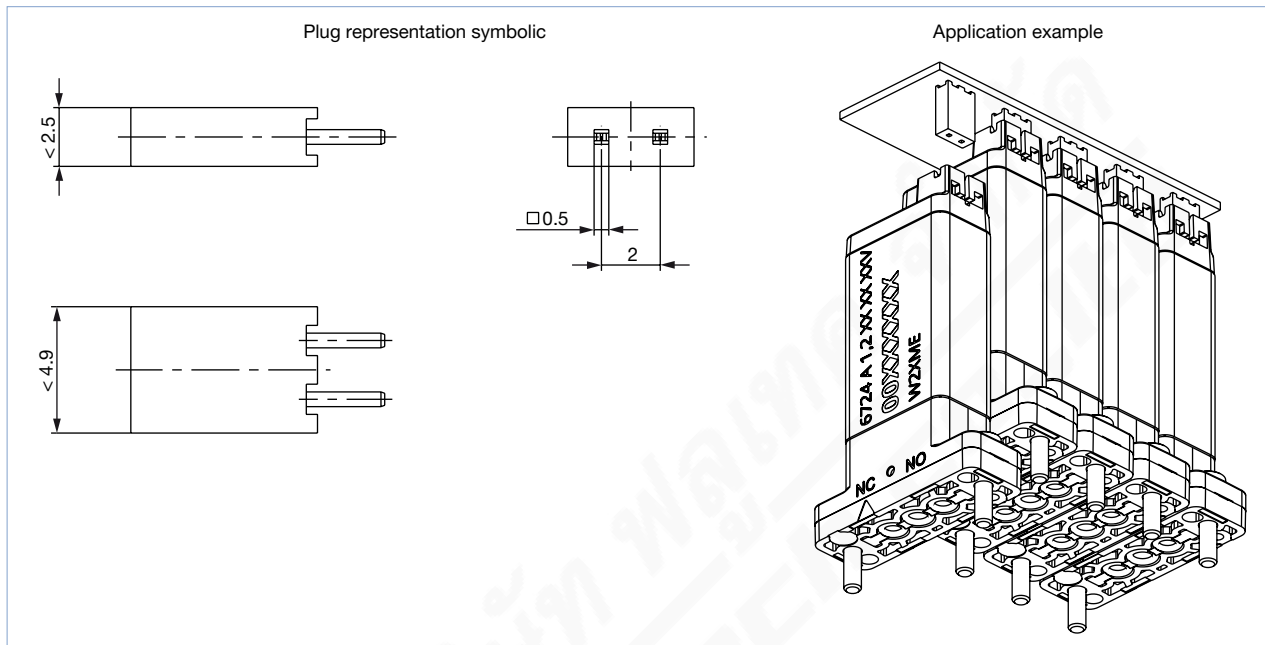

3.3. Connector with PCB

Note:

- Dimensions in mm
- The functional description can be found in the respective operating instructions.
- The dimensional drawing shown refers to the boost close, soft close and impulse electronics.

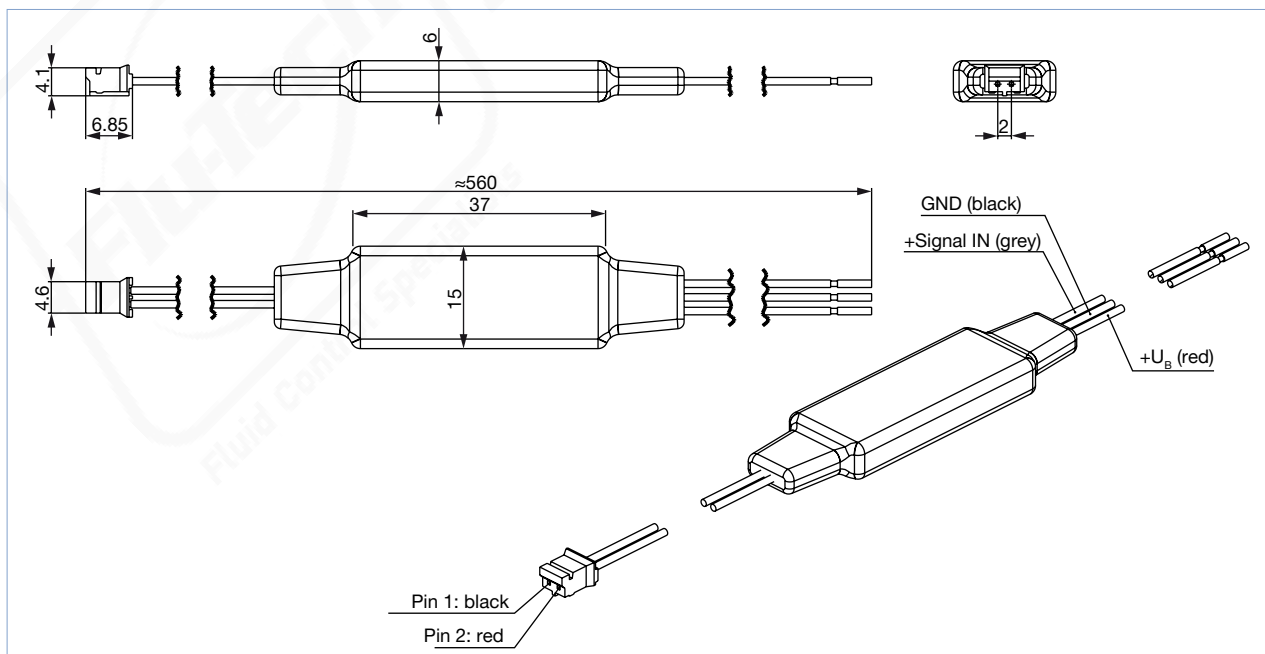

4. Ordering information

4.1. Bürkert eShop – Easy ordering and quick delivery



Bürkert eShop – Easy ordering and fast delivery

You want to find your desired Bürkert product or spare part quickly and order directly? Our online shop is available for you 24/7. Sign up and enjoy all the benefits.

[Order online now](#)

4.2. Bürkert product filter



Bürkert product filter – Get quickly to the right product

You want to select products comfortably based on your technical requirements? Use the Bürkert product filter and find suitable articles for your application quickly and easily.

[Try out our product filter](#)

4.3. Ordering chart

Connector without PCB

Detailed ordering information can be found in chapter “3.1. Connector without PCB” on page 4.

Connector with PCB “Boost Close”

The accessory electronics “Boost Close” has been specially developed for solenoid valves with WhisperValve actuator of **Type 6712 ▶** and **Type 6724 ▶** series. The electronics increase the tightness of the “Normally Closed” valve connection by reversing the polarity of the voltage applied to the valve. With Type 6712, the back pressure tightness is also significantly increased (see following table). The following is an example of a switching cycle.

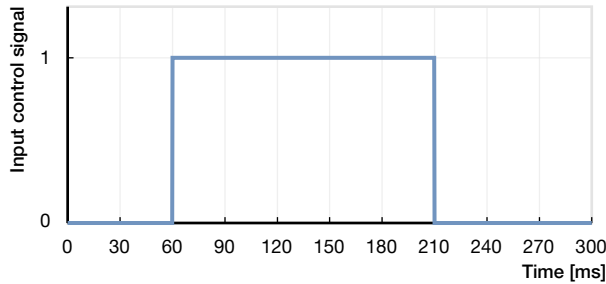

Control signal Boost Close

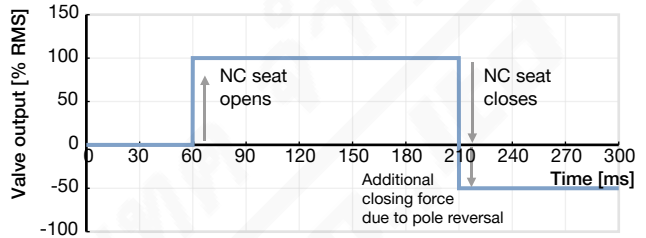

Valve voltage curve

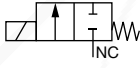

- The Boost Close electronics can be operated with 12 and 24 V valves.
- Further information can be found in the **Type 2503 ▶ Boost Close** operating instructions.
- Not suitable for the impulse version.
- The electronics cannot be used for solenoid valves.
- We would be pleased to support you with the design of a customer's own electronics for use in large-scale production, which fully exploits the properties of the unique WhisperValve actuator and is optimally adapted to the respective application.

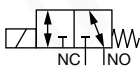
Circuit function	Valve type	Orifice [mm]	Pressure range			Max. differential pressure ^{1.)} [bar]	Seal material	Article no.
			NC ^{1.)} [bar]	COM [bar]	NO [bar]			
A, solenoid valve 2/2 way Direct-acting Normally closed 	6712	0.8	0...6	–	–	6 ^{2.)}	EPDM ^{6.)}	689998 
	6724	1.2	Vac...7 ^{3.)}	–	– ^{4.)}	7	EPDM FKM FFKM	
T, solenoid valve 3/2 way Direct-acting Flow direction optional Universal 	6724	1.2	Vac...7 ^{3.)}	0...5 ^{3.) 5.)}	Vac...2 ^{3.)}	7	EPDM FKM FFKM	

1.) **Caution!** If the operating voltage of the electronics is switched off, the pressure values are reduced again to the values specified in the data sheet for the valve types without electronics.

2.) Max. back pressure at the output of 5 bar is permissible.

3.) Connect technical vacuum (-0.8 bar) to NC or NO. Do not apply a vacuum at the valve outlet (COM /OUT), otherwise the flow rate may be considerably reduced.

4.) Up to 2 bar, the flow direction is also permissible against the default.

5.) Low vacuum due to back pressure at media flow permissible. In case of continuous operation with higher vacuum, there is a risk of flow reduction. In case of doubt, please contact your Bürkert sales office.

6.) The service life is reduced with EPDM. With FFKM the electronics lead to a significant reduction of the service life and is therefore not recommended.

Connector with PCB “Soft Close”

The accessory electronics “Soft Close” has been specially developed for solenoid valves with WhisperValve actuator of **Type 6724 ▶**. The switching noise of the valve is significantly reduced by the electronics through a targeted lowering of the voltage. At the time of switching, the operating voltage at the valve is not switched on and off abruptly, but “gently” by means of a ramp function. The following is an example of a switching cycle.

Control signal Soft Close

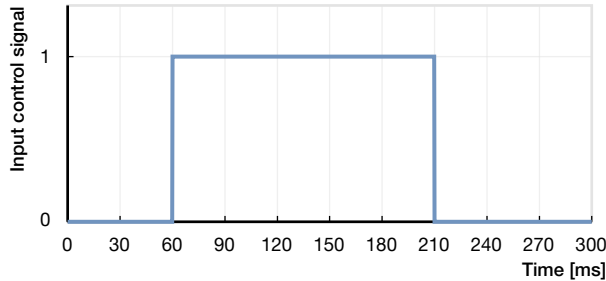

Valve voltage curve

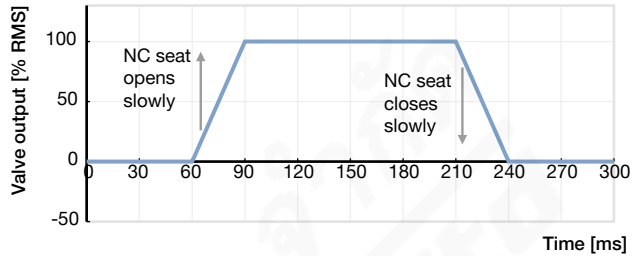

- Values < 20 dB(A) can be achieved.
- For optimum noise reduction, the valve should be mounted decoupled from the housing to avoid structure-borne noise (e.g. by attaching to supply lines or rubber suspension).
- The valve switching time is extended up to 30 ms by the electronics.
- The Soft Close electronics can be operated with 12 and 24 V valves, all materials and the circuit functions A, B and T.
- Further information can be found in the **Type 2503 ▶ Soft Close** operating instructions.
- Not suitable for Type 6712 and the impulse version Type 6724.
- We would be pleased to support you with the design of a customer’s own electronics for use in large-scale production, which fully exploits the properties of the unique WhisperValve actuator and is optimally adapted to the respective application.

Description	Article no.
Accessory electronics “Soft Close” with flying leads AWG 24	689999

Connector with PCB “Impulse”

The accessory electronics “Impulse” was specially developed for the impulse version of the solenoid valve **Type 6724 ▶**. With the help of the electronics, the impulse valve is switched by selectively reversing the polarity of the voltage. The electronics take over the control of the correct polarity to the valve. This means that no reversal logic needs to be provided in the control system. The following is an example of a switching cycle.

Control signal Impulse

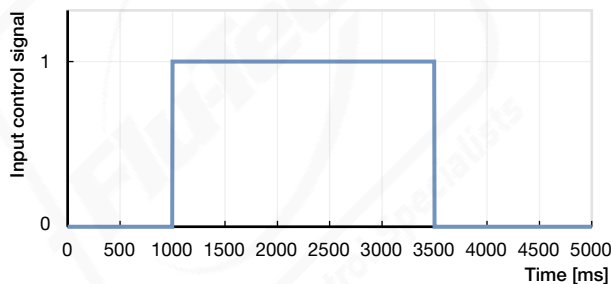

Valve voltage curve

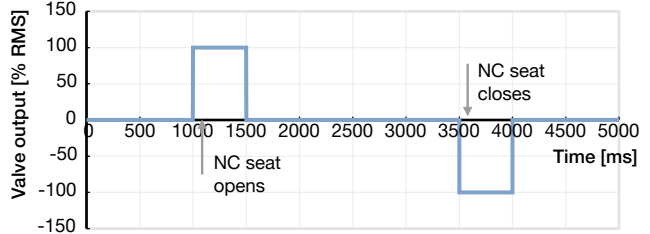

- The advantage is a very low heat input into the medium.
- The pulse electronics can be operated with 12 and 24 V pulse valves and all materials and the circuit functions P and S.
- Further information can be found in the operating instructions **Type 2503 ▶ Impulse** and operating instructions **Type 6724 ▶**.
- We will be pleased to support you in designing a customer-specific electronic system for use in large-scale production, which is optimally matched to the respective application.

Description	Article no.
Accessory electronics “Impulse” with flying leads AWG 24	366210

Visit product website ▶