



Pneumatic rotary actuator for the automation of ball and butterfly valves

- Combination with top control positioner Type 8691/2/3/4 possible
- Ideally suited for hygienic applications
- 100 % maintenance-free (welded stainless steel housing)
- Streamline design
- Standardised interface acc. to ISO 5211

Product variants described in the data sheet may differ from the product presentation and description.

Can be combined with

	Type 2654 ▶ 2/2-way ball valve 3-piece
	Type 2651 ▶ 2/2 or 3/2-way Ball Valve, 2-Piece
	Type 2657 ▶ Ball Valve, manually-operated
	Type 8691 ▶ Control head for decentralised automation of ELEMENT process valves
	Type 8692 ▶ Digital electro-pneumatic positioner for integrated mounting on process control valves
	Type 8693 ▶ Digital electro-pneumatic process controller for integrated mounting on process control valves

Type description

The pneumatic actuator Type 2053 enables the automated actuation of ball and butterfly valves. The linear stroke movement of the actuator piston is deflected into a 90° rotary movement of the drive shaft. The interface on the armature is designed according to ISO 5211. In addition, the rotary actuator can be combined with the 8691/2/3/4 series position feedback sensors.

The single-acting actuators are returned to the initial position by spring force, while double-acting actuators are returned by compressed air. The welded construction of the stainless steel housing ensures the actuator is 100 % maintenance-free.

Overall, the actuator is available in three different sizes: P0 - P1 - P2. All three sizes have an extremely high torque in the closing area despite their compact design. The air consumption per stroke cycle is very low due to the low cylinder volume. This offers a remarkable energy saving potential.

DTS 1000436877 EN Version: B Status: RL (released | freigegeben | valide) printed: 18.09.2023

FLU-TECH CO. LTD.

Email: sales@flutech.co.th **Website:** https://flutech.co.th

Tel: 02-384-6060, 086-369-5871-3 **Fax:** 02-384-5701 **LINE OA:** @flutech.co.th

Address (HQ): 845/3-4, Moo 3, Theparak Rd., T. Theparak, A. Mueang Samut Prakan, Samut Prakan, 10270, Thailand



Table of contents

1. General technical data	3
2. Circuit functions	3
3. Materials	3
3.1. Bürkert resistApp	3
3.2. Material specifications	4
Central section	4
Interface for ELEMENT control heads and positioners	4
Cover	4
Bottom plate	5
4. Dimensions	6
4.1. Version P0	6
4.2. Version P1	7
4.3. Version P2	8
5. Performance specifications	9
5.1. Torque chart	9
Single-acting	9
Double-acting	9
5.2. Air Consumption	9
6. Product operation	9
6.1. Functional overview	9
7. Networking and combination with other Bürkert products	10
8. Ordering information	10
8.1. Bürkert eShop	10
8.2. Bürkert product filter	11
8.3. Ordering chart	11
Double-acting - Control head/Positioner ready	11
Double-acting	11
Single-acting - Control head/Positioner ready	11
Single-acting	11
8.4. Ordering chart accessories	12
Form Seal for Control Units of Type 8691/8692/8693/8694	12
Angled connector	12
Silencer	12
Conversion sleeves	12

1. General technical data

Product properties	
Dimensions	Detailed information can be found in chapter "4. Dimensions" on page 6.
Material	
Housing	Stainless steel
Drive shaft	Stainless steel
Piston	PA
Seal	NBR
Performance data	
Rotation	90°
Control pressure	4.8...8 bar, single-acting 3.0...8 bar, double-acting Max. 8 bar
Media data	
Control medium	Filtered compressed air with or without oil
Dust content	Class 5 (< 40 µm particle size)
Particle density	Class 5 (< 10 mg/m³)
Pressure dew point	Class 4 (< 3 °C)
Oil concentration	Class 5 (< 25 mg/m³)
Process/Port connection & communication	
Pilot air ports	Threaded hole G 1/8
Environment and installation	
Valve interface	ISO 5211
Control Head/Positioner interface	ELEMENT FA03
Ambient temperature	- 10 °C...+60 °C

2. Circuit functions

Symbol	Description
	Control function A (CF A) Pneumatically operated 2/2-way on/off valve Flow direction above seat Normally closed by spring force
	Control function I (CF I) Pneumatically operated 2/2-way on/off valve on either side Bidirectional Switching position dependent on external control

3. Materials

3.1. Bürkert resistApp

Bürkert resistApp – Chemical resistance chart

You want to ensure the reliability and durability of the materials in your individual application case? Verify your combination of media and materials on our website or in our resistApp.

Start chemical resistance check

DTS 1000436877 EN Version: B Status: RL (released | freigegeben | valide) printed: 18.09.2023

3.2. Material specifications

Central section

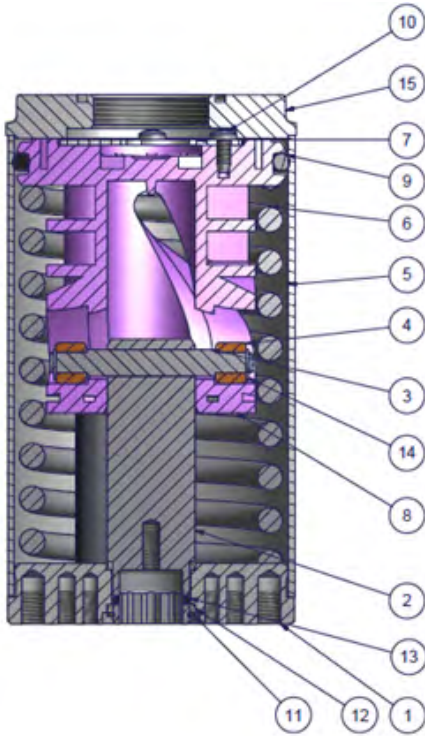

No.	Quantity	Element	Material
1	1	Bottom plate	304
2	1	Drive shaft	304
3	1	Pin	304/316L
4	2	Roller	20.401
5	1	Housing tube	304
6	1	Pressure spring	54SiCr6
7	1	Retaining washer	304
8	1	Piston	PA
9	1	O-Ring 72x5.2	NBR
10	3	Screw WN E5451 40x10-S	A2
11	1	Constant section retaining ring XFS-023	302
12	2	Sliding disk	IGLIDUR W300
13	1	O-Ring 19x2	NBR
14	2	Lock washer DIN 6799 - 5.0	A2
15	1	Cover	304

Interface for ELEMENT control heads and positioners

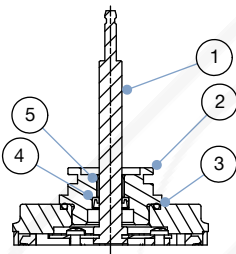

No.	Quantity	Element	Material
1	1	Shaft	304
2	1	Adaptor bolt	304
3	1	O-Ring 37.77x2.62	NBR
4	1	Shaft seal	EPDM
5	1	Socket	DU

Cover

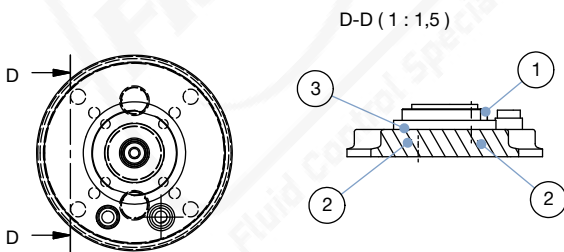

No.	Quantity	Element	Material
1	1	Press-in socket	304
2	1	Sealing	EPDM
3	1	Press-in shell	304

DTS 1000436877 EN Version: B Status: RL (released | freigegeben | valide) printed: 18.09.2023

Bottom plate

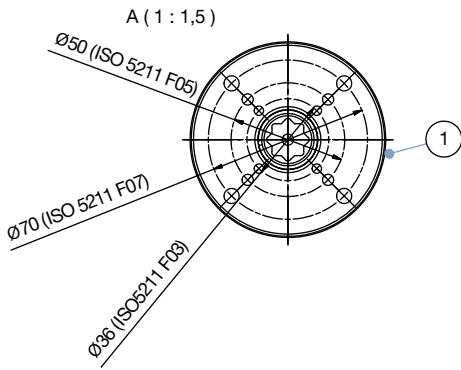

No.	Quantity	Element	Material
1	1	Bottom plate with interface acc. ISO 5211	304

DTS 1000436877 EN Version: B Status: RL (released | freigegeben | valide) printed: 18.09.2023

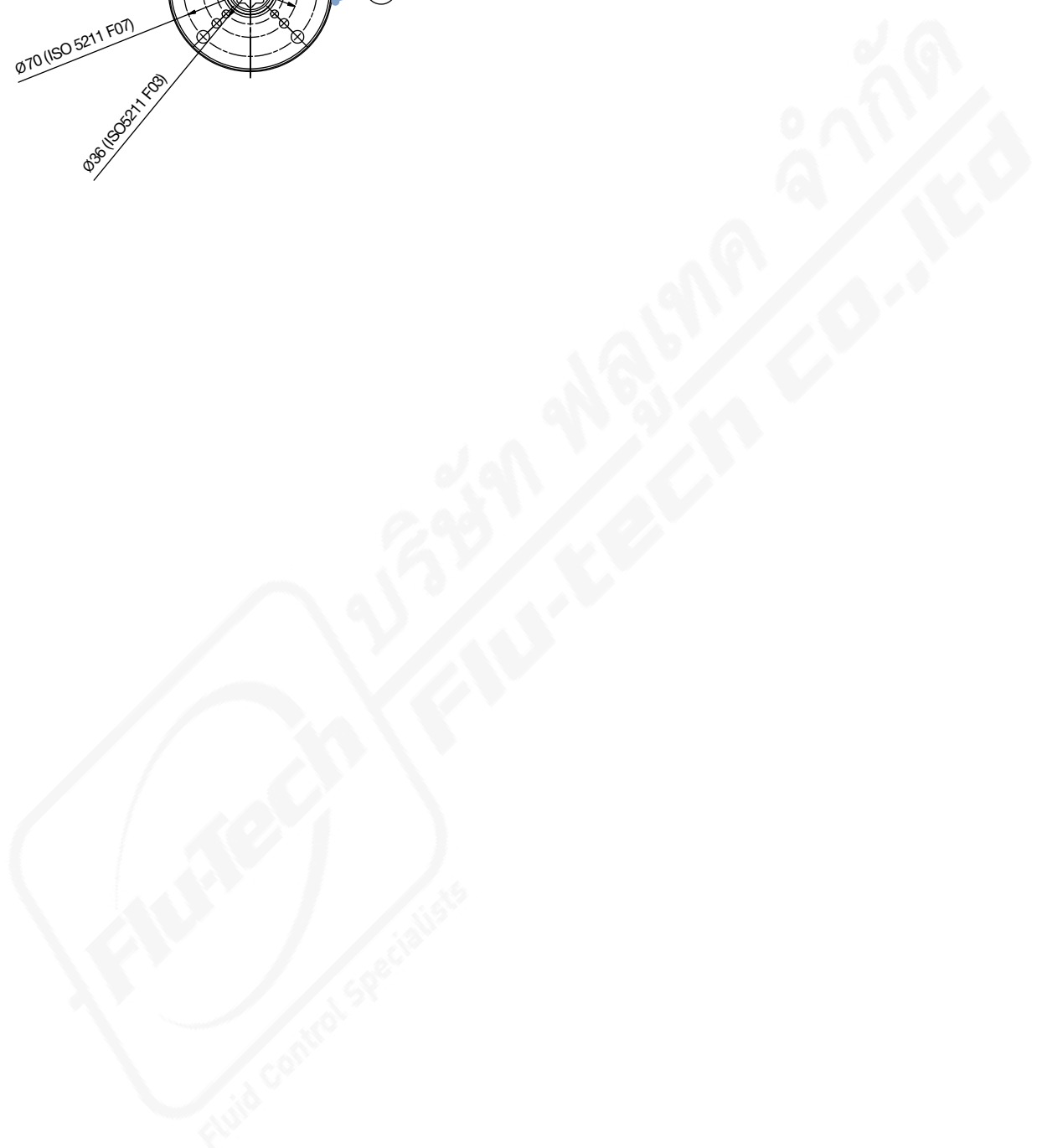

4. Dimensions

4.1. Version P0

Note:

Dimensions in mm

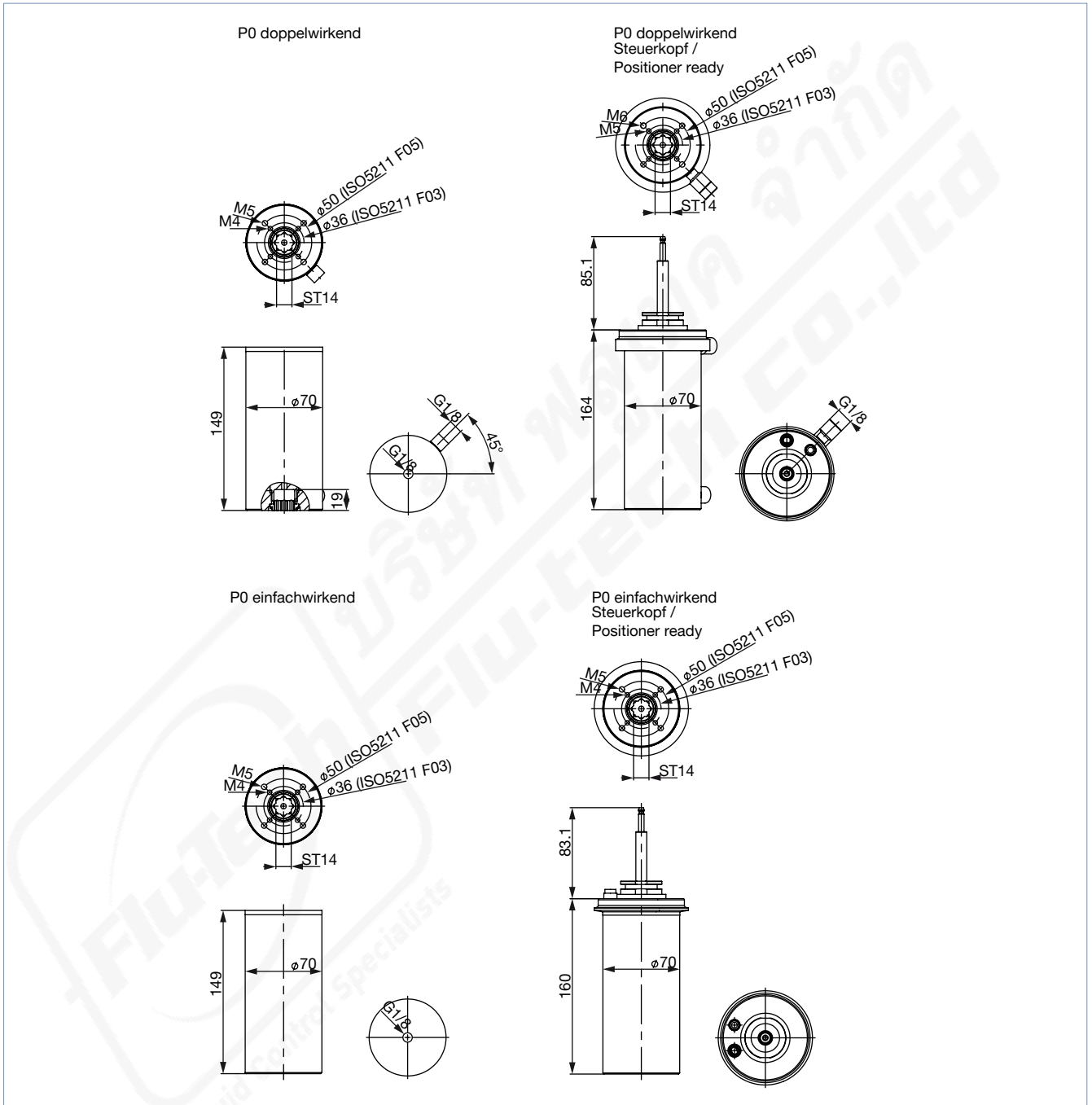

DTS 1000436877 EN Version: B Status: RL (released | freigegeben | valide) printed: 18.09.2023

4.2. Version P1

Note:
Dimensions in mm

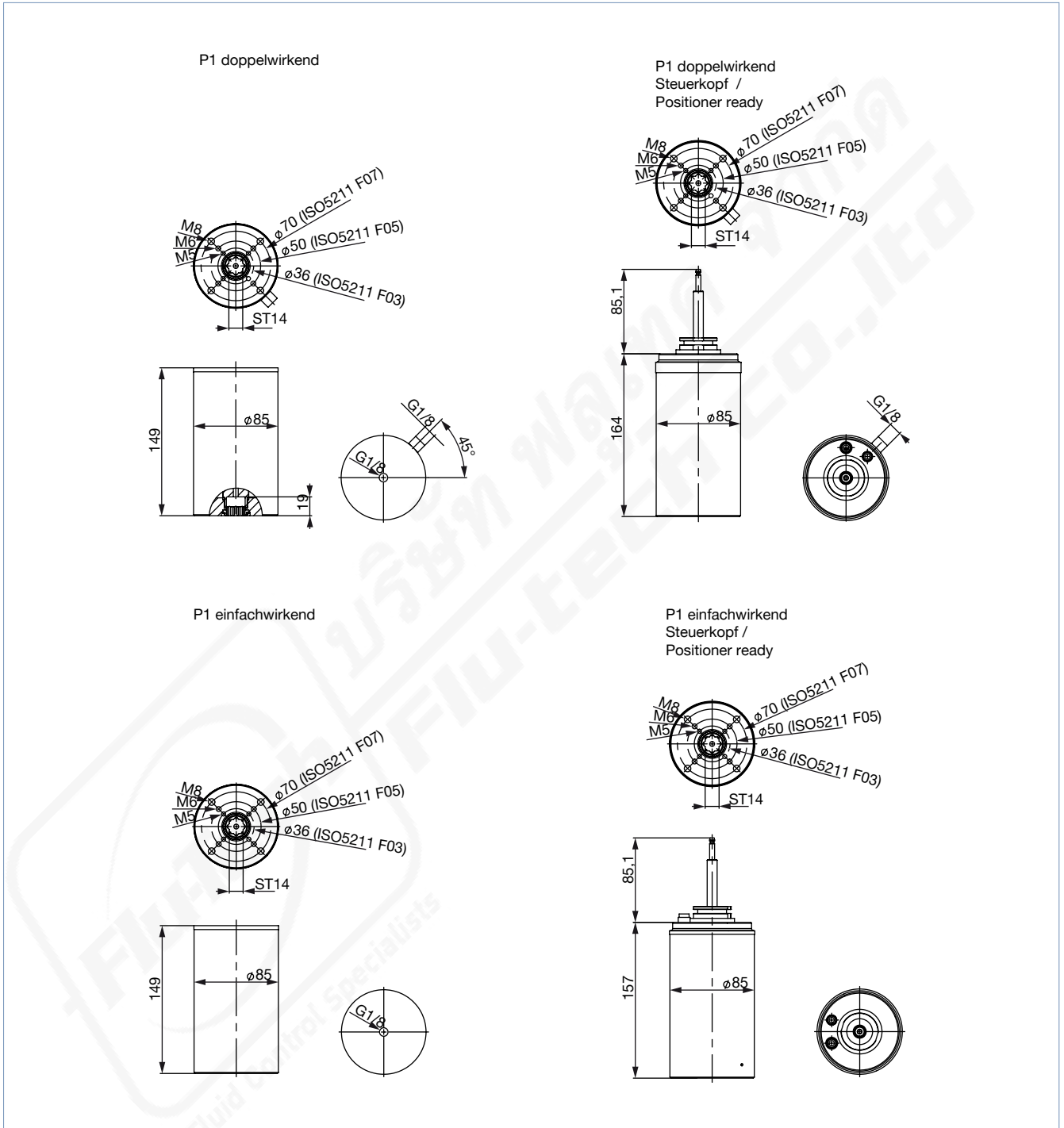

DTS 1000436877 EN Version: B Status: RL (released | freigegeben | valide) printed: 18.09.2023

4.3. Version P2

Note:
Dimensions in mm

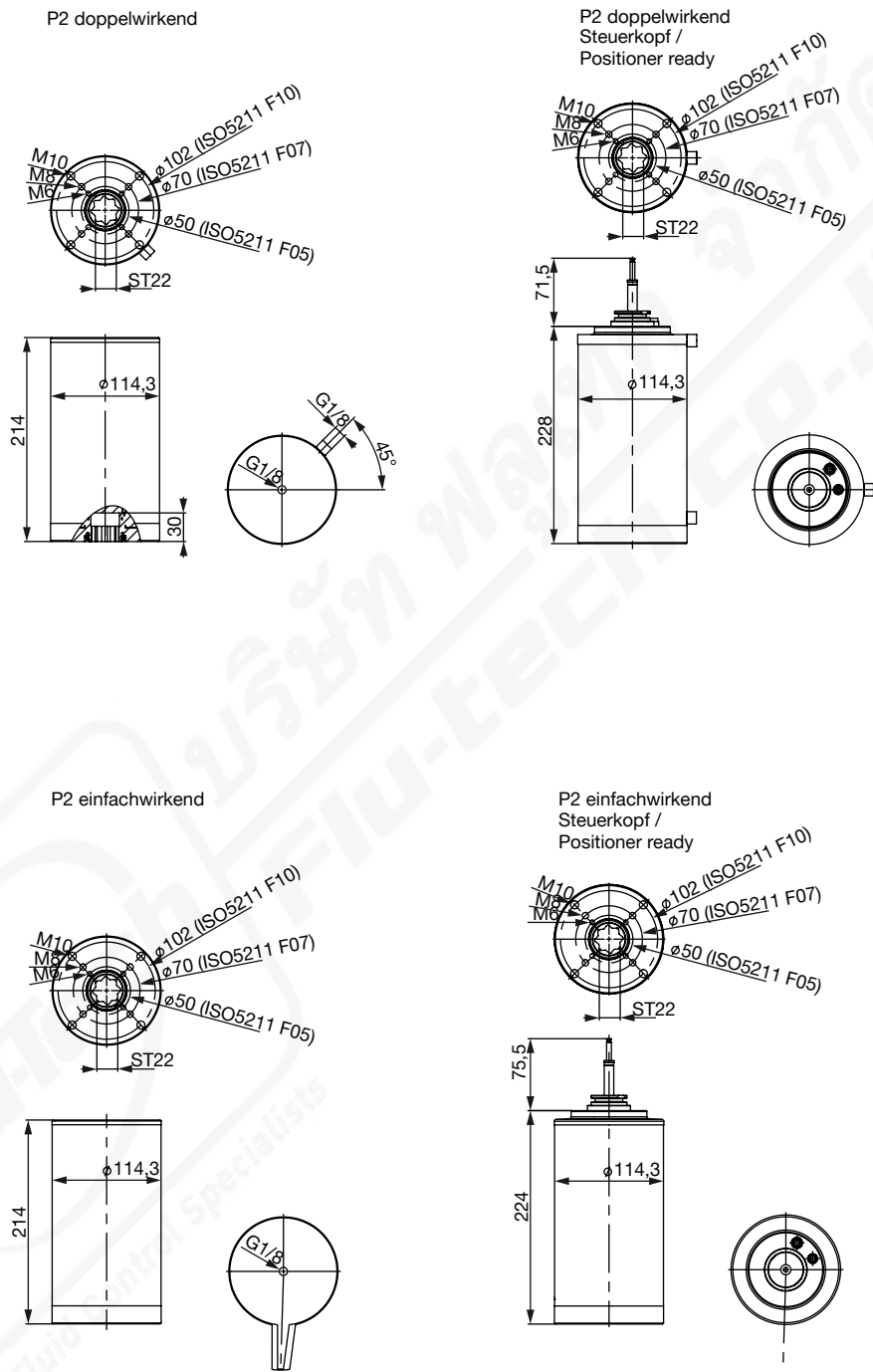

DTS 1000436877 EN Version: B Status: RL (released | freigegeben | valide) printed: 18.09.2023

5. Performance specifications

5.1. Torque chart

Single-acting

Note:

For the actuator choice, we recommend a safety torque equal to 1.3 times of the valve maximum torque.

Actuator size	Min. torque for 6 bar control pressure ^{1.)}
	[Nm]
P0	10
P1	28
P2	48

1.) For the balanced operation (ratio of the spring torque to the torque generated by compressed air) the actuator has to be operated with 6 bar compressed air. Lower control pressures reduce the torque.

Double-acting

Note:

For the actuator choice, we recommend a safety torque equal to 1.3 times of the valve maximum torque.

Actuator size	Torque (depending on the control pressure)			
	3 bar	4 bar	5 bar	6 bar
	[Nm]	[Nm]	[Nm]	[Nm]
P0	17	21	26	32
P1	26	36	44	50
P2	60	80	90	95

5.2. Air Consumption

Actuator size	Control function	Control pressure	Air consumption
		[bar]	[l/Stroke]
P0	double-acting	3...8	0.5...1.2
P1			0.8...2.0
P2			1.9...5.0
P0	single-acting	4.8...8	0.8...1.2
P1			1.2...2.0
P2			3.0...5.0

6. Product operation

6.1. Functional overview

Function	Description
	<ul style="list-style-type: none"> The linear lifting motion of the drive piston is redirected in a 90° rotational movement of the drive shaft. The return to the initial position of the single-acting actuators is caused by spring force. For the double-acting actuators, the movement in both directions is caused by compressed air. <p>Note for actuator size P2 in combination with Bürkert control units Position feedback „open“: Already at 75° opening angle Control range: 0...75° opening angle</p>

DTS 1000436877 EN Version: B Status: RL (released | freigegeben | valide) printed: 18.09.2023

7. Networking and combination with other Bürkert products

Note:

The actuator of Type 2053 is perfectly suited for the combined use with ELEMENT control heads/positioners (Type 8691/8692/8693/8694) and quarter turn valves like ball valves (Type 2651/2654/2657) and butterfly valves (Type 2671/2674). The described combination is named Type 8805.

Example:

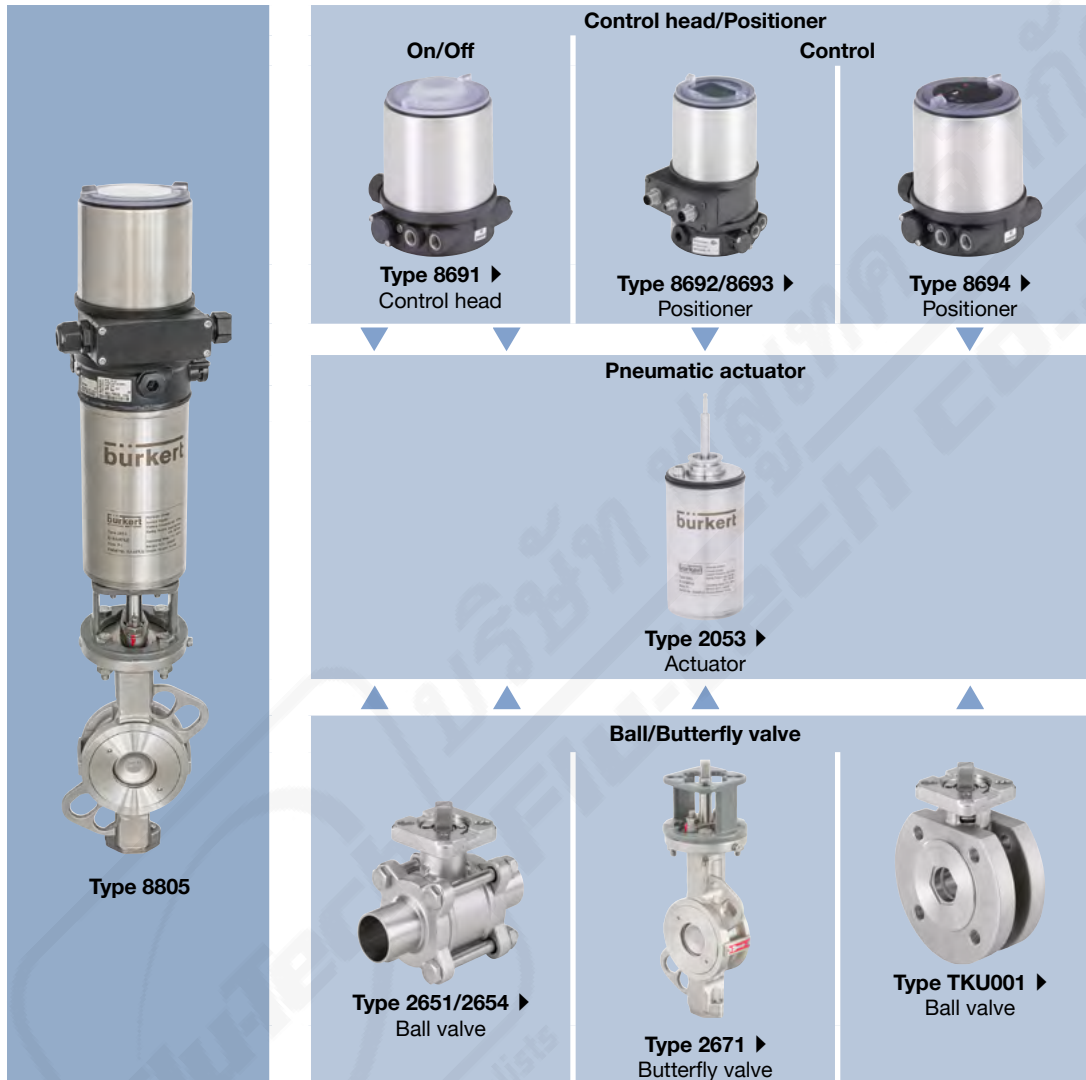

8. Ordering information

8.1. Bürkert eShop



Bürkert eShop – Easy ordering and quick delivery

You want to find your desired Bürkert product or spare part quickly and order directly? Our online shop is available for you 24/7. Sign up and enjoy all the benefits.

[Order online now](#)

DTS 1000436877 EN Version: B Status: RL (released | freigegeben | valide) printed: 18.09.2023

8.2. Bürkert product filter



Bürkert product filter – Get quickly to the right product

You want to select products comfortably based on your technical requirements? Use the Bürkert product filter and find suitable articles for your application quickly and easily.

Try out our product filter

8.3. Ordering chart

Double-acting - Control head/Positioner ready

Note:

For all assemblies of actuator Type 2053 with control unit Type 8691/8692/8693/8694 the Form Seal for Control Units is needed. The article number can be found in chapter “8.4. Ordering chart accessories” on page 12.

Actuator size	ISO 5211	Double square	Weight	Article no.
		[mm]	[kg]	
P0	F03-05	14	2.15	369736
P1	F03-05-07	14	2.95	369740
P2	F05-07-10	22	6.65	369744

Double-acting

Actuator size	ISO 5211	Double square	Weight	Article no.
		[mm]	[kg]	
P0	F03-05	14	1.9	369734
P1	F03-05-07	14	2.7	369738
P2	F05-07-10	22	6.3	369742

Single-acting - Control head/Positioner ready

Note:

For all assemblies of actuator Type 2053 with control unit Type 8691/8692/8693/8694 the Form Seal for Control Units is needed. The article number can be found in chapter “8.4. Ordering chart accessories” on page 12.

Actuator size	ISO 5211	Double square	Weight	Article no.
		[mm]	[kg]	
P0	F03-05	14	2.2	369735
P1	F03-05-07	14	3	369739
P2	F05-07-10	22	6.7	369743

Single-acting

Actuator size	ISO 5211	Double square	Weight	Article no.
		[mm]	[kg]	
P0	F03-05	14	1.95	369733
P1	F03-05-07	14	2.75	369737
P2	F05-07-10	22	6.4	369741

DTS 1000436877 EN Version: B Status: RL (released | freigegeben | valide) printed: 18.09.2023

8.4. Ordering chart accessories

Form Seal for Control Units of Type 8691/8692/8693/8694

Note:

For all assemblies of actuator Type 2053 with control unit Type 8691/8692/8693/8694 the Form Seal for Control Units is needed.

Description	Article no.
Form Seal for Control Units of Type 8691/8692/8693/8694	60014507 

Angled connector

Description	Article no.
Angled Connector G 1/8	780082 

Silencer

Description	Article no.
Silencer G 1/8	780779 

Conversion sleeves

Description	Article no.
Conversion sleeve star/square 14/9 mm	665288 
Conversion sleeve star/square 14/11 mm	665289 
Conversion sleeve square/square 17/14 mm	665290 
Conversion sleeve star/square 17/14 mm	773348 
Conversion sleeve star/square 17/11 mm	773343 
Conversion sleeve square/square 22/19 mm	773836 
Conversion sleeve star/square 22/17 mm	684858 
Conversion sleeve star/star 22/14 mm	666684 
Conversion sleeve star/square 22/11 mm	773344 
Conversion sleeve star/square 27/22 mm	774594 
Conversion sleeve square/square 27/19 mm	774279 
Conversion sleeve square/square 27/17 mm	774193 