



### Servo-assisted 2/2-way diaphragm valve

- Servo-assisted diaphragm valve up to DN 50
- Fix-coupled diaphragm opens without differential pressure
- Vibration-proof, block screwed coil system
- Energy-saving power reduction for all DC variants

Product variants described in the data sheet may differ from the product presentation and description.

#### Can be combined with



**Type 2518**  
Cable plug,  
form A according to  
DIN EN 175301 - 803



**Type 1087**  
Timer,  
form A according to  
DIN EN 175301 - 803

#### Type description

The 0290 valve is a servo-assisted diaphragm valve of the S.EV series. The valve opens without differential pressure. The opening process is facilitated by the fix coupling of the diaphragm to the magnetic core. The integrated 'soft-kick' function ensures gentle opening. Various diaphragm materials are available depending on the actual application. Stainless steel body variants complete the offering. The solenoid coils are moulded with a chemically resistant epoxy. A 'kick and drop' electronics assembly is moulded into the coil of all DC variants to reduce electrical power consumption. NEMA 4X is available on request.



## Table of contents

<b>1. General technical data</b>	<b>3</b>
<b>2. Circuit functions</b>	<b>4</b>
<b>3. Approvals and conformities</b>	<b>4</b>
3.1. General notes .....	4
3.2. Conformity .....	4
3.3. Standards .....	4
3.4. North America (USA/Canada) .....	4
3.5. Drinking water .....	4
3.6. Others .....	5
Fuel gases .....	5
<b>4. Materials</b>	<b>5</b>
4.1. Bürkert resistApp .....	5
4.2. Material specifications .....	5
<b>5. Dimensions</b>	<b>6</b>
5.1. Threaded version .....	6
5.2. Flange version according to DIN EN 1092 - 1 .....	6
<b>6. Performance specifications</b>	<b>7</b>
6.1. Power consumption .....	7
Standard version .....	7
Gas valve according to DIN EN 161 (variable code PO17) .....	7
<b>7. Ordering information</b>	<b>7</b>
7.1. Bürkert eShop .....	7
7.2. Bürkert product filter .....	7
7.3. Bürkert Product Enquiry Form .....	8
7.4. Ordering chart .....	8
Standard version with brass body .....	8
Standard version with stainless steel body .....	9
Gas valve according to DIN EN 161 (variable code PO17) .....	9
7.5. Ordering chart accessories .....	10
Cable plug Type 2518, form A according to DIN EN 175301 - 803 .....	10
Timer Type 1087, form A according to DIN EN 175301 - 803 .....	10

## 1. General technical data

Product properties	
Dimensions	Further information can be found in chapter "5. Dimensions" on page 6.
Material	
Seal	NBR, FKM, EPDM
Body	Brass, stainless steel 1.4581
Coil	Epoxy
Valve inner parts	Brass, stainless steel
Orifice	
Standard version	DN 12...DN 50
With approval according to DIN EN 161	DN 12...DN 25
Circuit function	A Further information can be found in chapter "2. Circuit functions" on page 4.
Thermal insulation class of solenoid coil	Epoxy coil class H
Performance data	
Duty cycle	Continuous operation 100 % duty cycle (unless otherwise specified on the type plate)
Switching time <sup>1)</sup>	
DN 12...DN 25	Opening: 100...250 ms Closing: 700...2000 ms
DN 32...DN 65	Opening: 100...250 ms Closing: 700...2000 ms
DN 12...DN 25 with approval according to DIN EN 161	Opening: 120...150 ms Closing: 130...250 ms
Electrical data	
Voltage	24 V/50 Hz, 24 V/DC, 24 V/UC, 110 V/50 Hz, 230 V/50 Hz
Voltage tolerance	± 10 %
Medium data	
Operating medium	
NBR	Neutral media (e.g. compressed air, water, hydraulic oil, oils without additives)
FKM	Per solutions, hot oils with additives
EPDM	Oil and grease-free media, (e.g. hot water)
NBR with approval according to DIN EN 161	Fuel gases of the 1st, 2nd and 3rd gas family
Medium temperature <sup>2)</sup>	
NBR	- 10 °C...+80 °C
FKM	0 °C...+ 120 °C
EPDM	-30 °C...+100 °C
NBR with approval according to DIN EN 161	0 °C...+80 °C
Process/Port connection & communication	
Electrical connection	Plug contacts according to DIN EN 175 301 -803 form A for cable plug <b>Type 2518</b> ▶. Further information can be found in chapter "Cable plug Type 2518, form A according to DIN EN 175301 -803" on page 10.
Approvals and certificates	
Degree of protection	IP65 with cable plug
North America (USA/Canada)	Further information can be found in chapter "3.4. North America (USA/Canada)" on page 4.
Drinking water	Further information can be found in chapter "3.5. Drinking water" on page 4.
Others	Further information can be found in chapter "3.6. Others" on page 5.
Environment and installation	
Installation position	As required, preferably with actuator upright
Ambient temperature	
Standard version	Max. +55 °C
With approval according to DIN EN 161	0 °C to +55 °C

1.) Measurement at +20 °C, 6 bar at the valve outlet, opening: pressure build-up 0...90 %, closing: pressure reduction 100...10 %

2.) Max. medium temperature for versions with high-performance electronics (encoding .../UC) is 90 °C.

## 2. Circuit functions

Symbol	Description
	<b>Circuit function A (CF A)</b> 2/2-way solenoid valve Servo-controlled Normally closed

## 3. Approvals and conformities

### 3.1. General notes

- The approvals and conformities listed below must be stated when making enquiries. This is the only way to ensure that the product complies with all required specifications.
- Not all available versions can be supplied with the below mentioned approvals or conformities.

### 3.2. Conformity

In accordance with the Declaration of Conformity, the product is compliant with the EU Directives.

### 3.3. Standards

The applied standards which are used to demonstrate compliance with the EU Directives are listed in the EU-Type Examination Certificate and/or the EU Declaration of Conformity.

### 3.4. North America (USA/Canada)

Approval	Description
	<b>Optional: UL Listed for the USA</b> The products are UL Listed for the USA according to: <ul style="list-style-type: none"> <li>UL 429 (electrically operated valves)</li> </ul>
	<b>Optional: UL Recognized for the USA</b> The products are UL Recognized for the USA according to: <ul style="list-style-type: none"> <li>UL 429 (electrically operated valves)</li> </ul>
	<b>Optional: CSA for Canada</b> The products are CSA approved for Canada according to: <ul style="list-style-type: none"> <li>CAN/CSA-C22.2 No. 139 - 19 (electrically operated valves)</li> </ul>

### 3.5. Drinking water

Conformity	Description
	<b>Suitable for use in drinking water applications</b> The materials comply with the assessment principles (UBA) for materials in contact with drinking water (TrinkwasserV).  PF36: Suitable for products with a maximum temperature of 60 °C (warm water)
	<b>Suitable for use in drinking water applications with WRAS/WRC approval</b>  PD23: Sealing materials with WRAS/WRC approval for DN 12...DN 25

DTS 1000024859 EN Version: W Status: RL (released | freigegeben | validé) printed: 08.04.2024

### 3.6. Others

#### Fuel gases

Conformity	Description
	<b>Fuel gases (valid for the variable code PO17)</b> The products comply with: <ul style="list-style-type: none"> <li>• Regulation (EU) 2016/426 – Appliances burning gaseous fuels and</li> <li>• DVGW DIN EN 161 (Automatic shut-off valves for gas burners and gas appliances)</li> </ul>
	<b>Optional: DIN EN 549:2023-07 certification</b> The wetted valve seals are compliant with DIN EN 549:2023-07 (Rubber materials for seals and diaphragms for gas appliances and gas equipment) for medium temperatures of 0 °C...+80 °C.

## 4. Materials

### 4.1. Bürkert resistApp

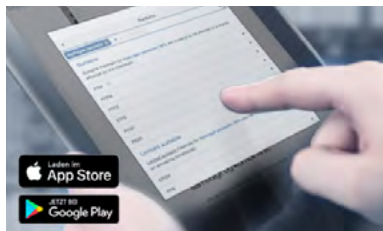

#### Bürkert resistApp – Chemical resistance chart

You want to ensure the reliability and durability of the materials in your individual application case? Verify your combination of media and materials on our website or in our resistApp.

[Start chemical resistance check](#)

### 4.2. Material specifications

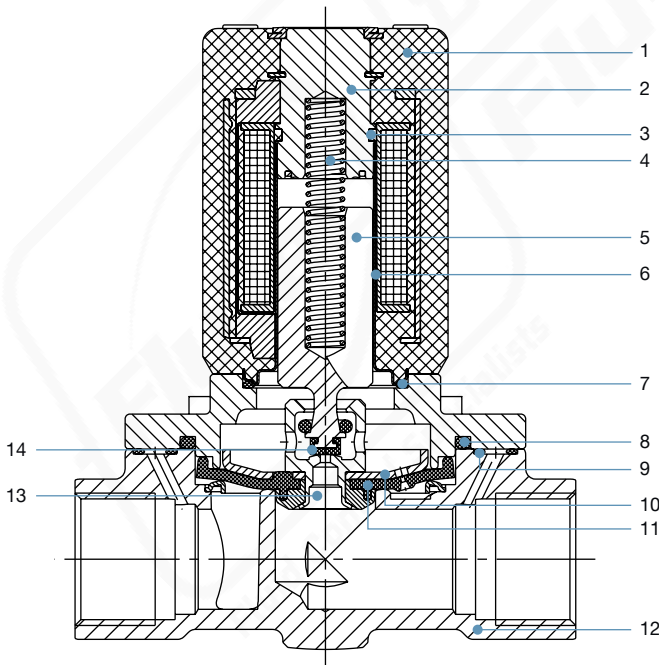

No.	Element	Material
1	Coil	Epoxy
2	Stopper	Stainless steel 1.4105, 1.4113 or 1.4523 (optional)
3	Shading ring	Brass variant: Copper
4	(AC variant only)	Stainless steel variant: Silver
4	Spring	Stainless steel 1.4310
5	Magnetic core	Stainless steel 1.4105 or 1.4113
6	Core guide tube	Stainless steel 1.4303
7	O-ring	NBR, FKM, EPDM
8	O-ring	NBR, FKM, EPDM
9	O-ring	NBR, FKM, EPDM
10	Diaphragm plate	Brass variant: CuZn37 Stainless steel variant: 1.4401
11	Diaphragm	NBR, FKM, EPDM
12	Body	Brass or stainless steel 1.4581
13	Pilot valve seat	Brass variant: MS Stainless steel variant: 1.4401
14	Seat seal	NBR, FKM, EPDM

## 5. Dimensions

### 5.1. Threaded version

**Note:**

- Dimensions in mm
- The dimensions D1 and F1 apply to G-threads.
- The dimensions D2 and F2 apply to NPT-threads.

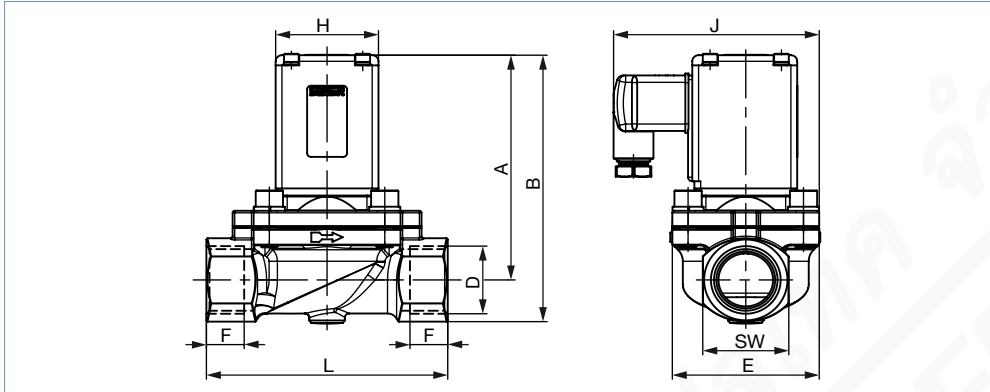

DN	A	B	G		NPT		E	L	SW	J	H
			D1	F1	D2	F2					
12	80	94	G 1/2	14	NPT 1/2	13.7	40	74.5	27	81	40
20	106	122	G 3/4	16	NPT 3/4	14	60	100	32	93	49
25	110.5	131	G 1	18	NPT 1	16.8	70	115	41	98	49
32	120	145	G 1 1/4	20	NPT 1 1/4	17.3	85	126	50	106	49
40	124	154	G 1 1/2	22	NPT 1 1/2	17.3	85	126	60	106	49
50	176	211	G 2	24	NPT 2	17.6	115	164	70	133	72
65	176	218.5	G 2 1/2	27	NPT 2 1/2	23.6	115	179	85	133	72

### 5.2. Flange version according to DIN EN 1092-1

**Note:**

- Dimensions in mm
- Flange versions are available on request.

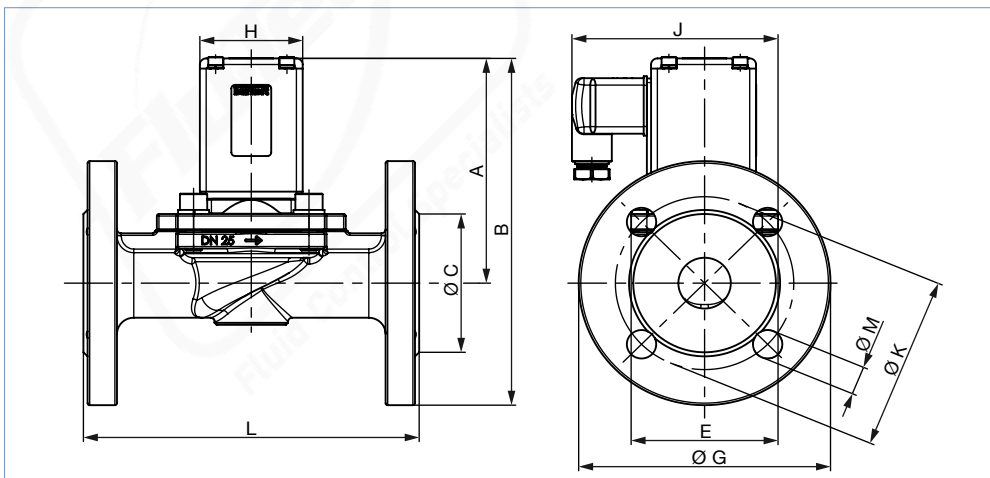

DN	A	B	C	E	Ø G	L	M	K	J	H
25	110.5	170.5	68	70	120	160	14	85	98	49
32	120	190	78	85	140	180	18	100	106	49
40	126	201	88	85	150	200	18	110	106	49
50	176	258.5	102	115	165	230	18	125	133	72

DTS 1000024859 EN Version: W Status: RL (released | freigegeben | valide) printed: 08.04.2024



## 6. Performance specifications

### 6.1. Power consumption

#### Standard version

Orifice [mm]	K <sub>v</sub> value water P→A [m <sup>3</sup> /h]	Port connection A/B and P	Electrical power consumption				Weight [kg]
			Inrush		Operation		
			AC [VA]	AC/DC <sup>1)</sup> [W]	AC [VA/W]	AC/DC <sup>1)</sup> [W]	
12	1.8	G ½	100	80	25/10	6	1.0
20	6.5	G ¾	120	100	32/16	9	1.4
25	10.0	G 1	120	100	32/16	9	1.8
32	16.0	G 1¼	120	100	32/16	9	2.7
40	16.0	G 1½	120	100	32/16	9	3.1
50	38.0	G 2	–	30 <sup>1)</sup>	–	30	6.5

1.) The coil with Kick and Drop electronics is an universal current coil (frequency coding: UC) that is suitable for AC and DC.  
 2.) With 24 V only DC

#### Gas valve according to DIN EN 161 (variable code PO17)

Orifice [mm]	K <sub>v</sub> value water P→A [m <sup>3</sup> /h]	Port connection A/B and P	Electrical power consumption				Weight [kg]
			Inrush		Operation		
			AC [VA]	AC/DC <sup>1)</sup> [W]	AC [VA/W]	AC/DC <sup>1)</sup> [W]	
12	1.8	G ½	100 to 120	80	25/10	6	1.0
20	6.5	G ¾		100	32/16	9	1.4
25	10.0	G 1	100	100	32/16	9	1.8

## 7. Ordering information

### 7.1. Bürkert eShop



#### Bürkert eShop – Easy ordering and quick delivery

You want to find your desired Bürkert product or spare part quickly and order directly? Our online shop is available for you 24/7. Sign up and enjoy all the benefits.

[Order online now](#)

### 7.2. Bürkert product filter



#### Bürkert product filter – Get quickly to the right product

You want to select products comfortably based on your technical requirements? Use the Bürkert product filter and find suitable articles for your application quickly and easily.

[Try out our product filter](#)

### 7.3. Bürkert Product Enquiry Form

**Bürkert Product Enquiry Form – Your enquiry quickly and compactly**

Would you like to make a specific product enquiry based on your technical requirements? Use our Product Enquiry Form for this purpose. There you will find all the relevant information for your Bürkert contact. This will enable us to provide you with the best possible advice.

Fill out the form now

### 7.4. Ordering chart

#### Standard version with brass body

**Note:**

All valves are delivered with a cable plug.

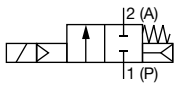
Circuit function	Port connection	Orifice	K <sub>v</sub> value water [m <sup>3</sup> /h]	Pressure range [bar]	Weight [kg]	Article no.			
						024/50 [V/Hz]	024 / AC/DC <sup>1.)</sup> [V/Hz]	230/50 [V/Hz]	110/50 [V/Hz]
<b>CF A</b> 2/2-way solenoid valve Servo-controlled Normally closed 	<b>Seal material NBR</b>								
	G ½	12	1.8	0...16	0.7	043816 ☒	050294 ☒	044373 ☒	049500 ☒
	G ¾	20	6.5	0...16	1.4	058766 ☒	049518 ☒	045292 ☒	057127 ☒
	G 1	25	10.0	0...16	1.8	048171 ☒	053675 ☒	045293 ☒	053869 ☒
	G 1¼	32	16.0	0...12	2.6	085290 ☒	085291 ☒	052513 ☒	085292 ☒
	G 1½	40	16.0	0...12	3.0	085294 ☒	085295 ☒	085297 ☒	085296 ☒
	G 2	50	38.0	0...12	6.7	–	085299 ☒ <sup>3.)</sup>	085301 ☒ <sup>2.)</sup>	085300 ☒ <sup>2.)</sup>
	<b>Seal material FKM</b>								
	G ½	12	1.8	0...16	0.7	048707 ☒	049229 ☒	042886 ☒	059240 ☒
	G ¾	20	6.5	0...16	1.4	053910 ☒	053674 ☒	049745 ☒	067973 ☒
	G 1	25	10.0	0...16	1.8	066270 ☒	066981 ☒	058627 ☒	067974 ☒
	G 1¼	32	16.0	0...12	2.6	120631 ☒	017457 ☒	087203 ☒	137478 ☒
	G 1½	40	16.0	0...12	3.0	228118 ☒	089619 ☒	087663 ☒	–
	G 2	50	38.0	0...12	6.7	–	120952 ☒ <sup>3.)</sup>	088551 ☒ <sup>2.)</sup>	–
	<b>Seal material EPDM</b>								
	G ½	12	1.8	0...16	0.7	045931 ☒	049050 ☒	044816 ☒	049055 ☒
	G ¾	20	6.5	0...16	1.4	065033 ☒	058427 ☒	045290 ☒	069138 ☒
	G 1	25	10.0	0...16	1.8	054245 ☒	057155 ☒	045291 ☒	064887 ☒
	G 1¼	32	16.0	0...12	2.6	087204 ☒	072962 ☒	085259 ☒	076763 ☒
	G 1½	40	16.0	0...12	3.0	073290 ☒	079629 ☒	087732 ☒	–
	G 2	50	38.0	0...12	6.7	–	120104 ☒ <sup>3.)</sup>	077494 ☒ <sup>2.)</sup>	121308 ☒ <sup>2.)</sup>

– = not available

1.) The coil with Kick and Drop electronics is an universal current coil (frequency coding: UC) that is suitable for AC and DC. Make sure that sufficient power is available (see "6. Performance specifications" on page 7).

2.) The valve is supplied with a cable plug with integrated rectifier.

3.) DC only

DTS 1000024859 EN Version: W Status: RL (released | freigegeben | valide) printed: 08.04.2024



**Standard version with stainless steel body**

**Note:**

All valves are delivered with a cable plug.

Circuit function	Port connection	Orifice	K <sub>v</sub> value water [m <sup>3</sup> /h]	Pressure range [bar]	Weight [kg]	Article no. per voltage/frequency			
						024/50 [V/Hz]	024 / AC/DC <sup>1.)</sup> [V/Hz]	230/50 [V/Hz]	110/50 [V/Hz]
<b>CF A</b> 2/2-way solenoid valve Servo-controlled Normally closed 	<b>Seal material NBR</b>								
	G ½	12	1.8	0...16	0.7	043659	053595	043654	052358
	G ¾	20	6.5	0...16	1.3	068338	018754	065121	-
	G 1	25	10.0	0...16	1.7	068510	061974	065414	067696
	<b>Seal material FKM</b>								
	G ½	12	1.8	0...16	0.7	048708	049987	042888	058407
	G ¾	20	6.5	0...16	1.3	065362	066381	064701	066594
	G 1	25	10.0	0...16	1.7	018121	065542	066125	069477
	<b>Seal material EPDM</b>								
	G ½	12	1.8	0...16	0.7	045765	048606	043553	049053
	G ¾	20	6.5	0...16	1.3	066460	059910	065025	025870
	G 1	25	10.0	0...16	1.7	059890	018348	059901	054044

- = not available

1.) The coil with Kick and Drop electronics is an universal current coil (frequency coding: UC) that is suitable for AC and DC. Make sure that sufficient power is available (see "6. Performance specifications" on page 7).

**Gas valve according to DIN EN 161 (variable code PO17)**

**Note:**

All valves are delivered with a cable plug.

Circuit function	Port connection	Orifice	K <sub>v</sub> value water [m <sup>3</sup> /h]	Pressure range [bar]	Weight [kg]	Article no. per voltage/frequency		
						024 / AC/DC <sup>1.)</sup> [V/Hz]	230/50 [V/Hz]	230 / AC/DC <sup>1.)</sup> [V/Hz]
<b>CF A</b> 2/2-way solenoid valve Servo-controlled Normally closed 	<b>Seal material NBR</b>							
	G ½	12	1.8	0...5	0.7	280855	266512	281001
	G ¾	20	6.5		1.4	280877	266513	280878
G 1	25	10.0	1.8		280879	266515	280880	

1.) The coil with Kick and Drop electronics is an universal current coil (frequency coding: UC) that is suitable for AC and DC. Make sure that sufficient power is available (see "6. Performance specifications" on page 7).

**Further versions on request**

<b>Approval</b> Further information can be found in chapter "3. Approvals and conformities" on page 4.	<b>Voltage</b> Further voltages on request
<b>Process connection</b> Flange connection according to DIN EN 1092-1 (DN 25...DN 50)	

DTS 1000024859 EN Version: W Status: RL (released | freigegeben | valide) printed: 08.04.2024

### 7.5. Ordering chart accessories

#### Cable plug Type 2518, form A according to DIN EN 175301 - 803

**Note:**

- Dimensions in mm
- For further versions see data sheet **Type 2518** ▶.

Cable plug	Dimensions	Version	Voltage	Article no.
		Without circuitry (AC/DC)	0...250 V AC/DC	314802
		With LED (AC/DC)	12...24 V AC/DC	314812
		With LED and varistor (AC/DC)	12...24 V AC/DC	314820
		With rectifier, LED and varistor	12...24 V AC/DC	314816
		Without circuitry (AC/DC) with silicone seal for higher ambient temperature, e.g. steam version (NA07)	0...250 V AC/DC	361687

#### Timer Type 1087, form A according to DIN EN 175301 - 803

**Note:**

Refer to data sheet **Type 1087** ▶ for more information about the timer.

Timer	Approval	Product code	Voltage range	Article no.
	-	1087-A-BCH-UC-28	10...30 V AC/DC	348828
	-	1087-A-BDK-UC-28	24...240 V AC/DC	348829
	cURus	1087-A-BCH-UC-28*PU01	10...30 V AC/DC	348906
	cURus	1087-A-BDK-UC-28*PU01	24...240 V AC/DC	348907
	-	1087-A-BFW-UC-29	10...48 V AC/DC	348830
	-	1087-A-BDX-UC-29	110...240 V AC/DC	348831
	cURus	1087-A-BFW-UC-29*PU01	10...48 V AC/DC	348908
	cURus	1087-A-BDX-UC-29*PU01	110...240 V AC/DC	348909

DTS 1000024859 EN Version: W Status: RL (released | freigegeben | valide) printed: 08.04.2024