





Piston valve, 3/2-way, servo-assisted

- Servo-assisted piston valve from DN 8 to DN 40
- Increased operational safety with pivoted armature technology
- Service-friendly manual override
- Energy-saving “Kick and Drop” or pulse coils
- Explosion-proof variants available on request

Product variants described in the data sheet may differ from the product presentation and description.

Can be combined with

	Type 2518 Cable plug, form A according to DIN EN 175301 - 803	▶
	Type 2516 Cable plug, form C according to DIN EN 175301 - 803	▶
	Type 1087 Timer, form A according to DIN EN 175301 - 803	▶

Type description

The valve 6430 is a servo-assisted 3/2-way piston valve. If the valve is not supplied with auxiliary pilot air, a minimum differential pressure is required for the function. Variants: For neutral liquids and gases in the pressure range 1 - 16 bar in the function NC and NO. -For technical vacuums up to 3 bar in the function NC and NO. - With auxiliary pilot air for vacuums up to 8 bar in the function NC and NO. All variants are available as an impulse version to secure the switching position even in the event of power interruptions. The Type 6430 is equipped with a manual override for start-up or manual operation (exception: impulse version). To reduce electrical power consumption during operation, coils with integrated “Kick and Drop” (KD) electronics featuring double coil technology are available. A maintenance-free, media-separated 3/2-way pivoted armature valve Type 0331 is used as a pilot valve. In combination with a plug to DIN EN 175301 – 803 Form A, the valves satisfy degree of protection IP65.

DTS 1000395477 EN Version: D Status: RL (released | freigegeben | validé) printed: 15.01.2024

FLU-TECH CO. LTD.

Email: sales@flutech.co.th **Website:** https://flutech.co.th

Tel: 02-384-6060, 086-369-5871-3 **Fax:** 02-384-5701 **LINE OA:** @flutech.co.th

Address (HQ): 845/3-4, Moo 3, Theparak Rd., T. Theparak, A. Mueang Samut Prakan, Samut Prakan, 10270, Thailand



Table of contents

1. General technical data	3
2. Circuit functions	4
3. Approvals and conformities	4
3.1. General notes.....	4
3.2. Conformity	4
3.3. Standards.....	4
3.4. Explosion protection	5
3.5. North America (USA/Canada)	5
4. Materials	6
4.1. Bürkert resistApp	6
4.2. Material specifications	6
Standard and vacuum version	6
External air controlled version.....	7
5. Dimensions	8
5.1. Standard and vacuum version	8
Pilot valve configuration.....	8
5.2. Vacuum version Low-Power	9
Pilot valve configuration.....	9
5.3. External air controlled version.....	10
Pilot valve configuration.....	10
5.4. ATEX/IECEX version	11
Cable version	11
Terminal box version	12
Pilot valve configuration.....	13
6. Ordering information	14
6.1. Bürkert eShop	14
6.2. Bürkert product filter.....	14
6.3. Bürkert Product Enquiry Form	14
6.4. Ordering chart	15
Standard version.....	15
Standard version as impulse valve	15
Vacuum version.....	16
Vacuum version as impulse valve	16
Vacuum version Low-Power	17
6.5. External air controlled version.....	18
6.6. Ordering chart accessories.....	19
Cable plug Type 2516, form C according to DIN EN 175301 - 803.....	19
Cable plug Type 2518, form A according to DIN EN 175301 - 803	19
Threaded connection, reduction, cylindrical UNI-ISO 228/1	19

DTS 1000395477 EN Version: D Status: RL (released | freigegeben | validé) printed: 15.01.2024

1. General technical data

Product properties	
Dimensions	Further information can be found in chapter "5. Dimensions" on page 8.
Material	
Seal	NBR, PUR, FKM, (EPDM on request)
Body	Brass (DN 8...DN 20), gunmetal (DN 25...DN 40)
Coil	Epoxy
Orifice	DN 8, DN 12, DN 20, DN 25, DN 40
Circuit function	C and D Further information can be found in chapter "2. Circuit functions" on page 4.
Thermal insulation class of solenoid coil	Epoxy coil class H
Performance data	
Duty cycle	100 % continuous operation (unless otherwise specified on the type plate)
Switching time ¹⁾	
DN 8	Opening: 25 ms Closing: 30 ms
DN 12	Opening: 30 ms Closing: 60 ms
DN 20	Opening: 35 ms Closing: 270 ms
DN 25	Opening: 50 ms Closing: 300 ms
DN 40	Opening: 80 ms Closing: 740 ms
Electrical data	
Power consumption	
Standard version, vacuum version and external air controlled version	Inrush AC: 30 VA Hold AC: 15 VA/8 W DC cold/warm: 11 W/8 W
Vacuum version Low-Power	DC cold/warm: 3.4 W/2 W
Impulse version	Hold AC: 20 VA/11 W DC cold/warm: 11 W/8 W
Explosion-proof version	Inrush/Hold: 40 W/3 W
Voltage tolerance	± 10 %
Medium data	
Operating medium ²⁾	
Standard version	<ul style="list-style-type: none"> Neutral gases and liquids (e.g. compressed air, water, low-viscosity oils) Oil- and grease-free media with EPDM
Vacuum version and external air controlled version	Neutral gases, compressed air, vacuum (low vacuum)
Medium temperature	
NBR	0 °C...+80 °C
PUR	0 °C...+80 °C
FKM	0 °C...+90 °C
EPDM	0 °C...+90 °C
Viscosity	Max. 21 mm ² /s (21 cSt)
Process/Port connection & communication	
Electrical connection	
Standard version, vacuum version and external air controlled version	Plug contacts according to DIN EN 175 301 - 803 form A for cable plug Type 2518 ▶. Further information can be found in chapter "Cable plug Type 2518, form A according to DIN EN 175301 - 803" on page 19.
Vacuum version Low-Power	Plug contacts according to DIN EN 175 301 - 803 form C for cable plug Type 2516 ▶. Further information can be found in chapter "Cable plug Type 2516, form C according to DIN EN 175301 - 803" on page 19.
Explosion-proof version	With cable outlet 3 x 0.5 mm ² or terminal box
Port connection	G ¼, G ½, G ¾, G 1, G 1½ (NPT on request)

Approvals and conformities	
Degree of protection	IP65 with cable plug, cable outlet or terminal box
Explosion protection	Further information can be found in chapter “3.4. Explosion protection” on page 5.
Environment and installation	
Installation position	As required, preferably with actuator upright
Ambient temperature	0 °C...+55 °C -20 °C...+55 °C (EPDM)

- 1.) Measurement at +20 °C, 6 bar at the valve outlet, opening: pressure build-up 0...90 %, closing: pressure reduction 100...10 %
 2.) Media resistance according to the material combination

2. Circuit functions

Symbol	Description
	Circuit function C (CF C) 3/2-way solenoid valve Servo-controlled, with manual override Normally closed
	Circuit function C (CF C) 3/2-way impulse solenoid valve Servo-controlled
	Circuit function C (CF C) 3/2-way solenoid valve Servo-controlled, with auxiliary pilot air, with manual override Normally closed
	Circuit function D (CF D) 3/2-way solenoid valve Servo-controlled, with manual override Normally open
	Circuit function D (CF D) 3/2-way solenoid valve Servo-controlled, with auxiliary pilot air, with manual override Normally open

3. Approvals and conformities

3.1. General notes

- The approvals and conformities listed below must be stated when making enquiries. This is the only way to ensure that the product complies with all required specifications.
- Not all available versions can be supplied with the below mentioned approvals or conformities.

3.2. Conformity



In accordance with the Declaration of Conformity, the product is compliant with the EU Directives.

3.3. Standards



The applied standards which are used to demonstrate compliance with the EU Directives are listed in the EU-Type Examination Certificate and/or the EU Declaration of Conformity.

DTS 1000395477 EN Version: D Status: RL (released | freigegeben | valide) printed: 15.01.2024

3.4. Explosion protection

Approval	Description					
 	<p>Optional: Explosion protection according to category 2 (zone 1/21)</p> <p>Ex marking of the components according to the following table:</p>					
	<table border="1"> <thead> <tr> <th colspan="2">Coil Type ACP016</th> </tr> <tr> <th>Coils with cable outlet</th> <th>Coils with terminal box</th> </tr> </thead> <tbody> <tr> <td> <p>ATEX: EPS 16 ATEX 1 111 X II 2 G Ex mb IIC T4 Gb II 2 D Ex mb IIIC T130 °C Db</p> <p>IECEX: IECEX EPS 16.0049X Ex mb IIC T4 Gb Ex mb IIIC T130 °C Db</p> </td> <td> <p>ATEX: PTB 15 ATEX 1011 U II 2G Ex eb mb IIC T4 Gb II 2D EX mb tb IIIC T130 °C</p> <p>IECEX: IECEX PTB 15.0037 U II eb mb IIC T4 Gb II mb tb IIIC T130 °C Db</p> </td> </tr> </tbody> </table>	Coil Type ACP016		Coils with cable outlet	Coils with terminal box	<p>ATEX: EPS 16 ATEX 1 111 X II 2 G Ex mb IIC T4 Gb II 2 D Ex mb IIIC T130 °C Db</p> <p>IECEX: IECEX EPS 16.0049X Ex mb IIC T4 Gb Ex mb IIIC T130 °C Db</p>
Coil Type ACP016						
Coils with cable outlet	Coils with terminal box					
<p>ATEX: EPS 16 ATEX 1 111 X II 2 G Ex mb IIC T4 Gb II 2 D Ex mb IIIC T130 °C Db</p> <p>IECEX: IECEX EPS 16.0049X Ex mb IIC T4 Gb Ex mb IIIC T130 °C Db</p>	<p>ATEX: PTB 15 ATEX 1011 U II 2G Ex eb mb IIC T4 Gb II 2D EX mb tb IIIC T130 °C</p> <p>IECEX: IECEX PTB 15.0037 U II eb mb IIC T4 Gb II mb tb IIIC T130 °C Db</p>					

3.5. North America (USA/Canada)

Approval	Description
	<p>Optional: UL Recognized for the USA and Canada (valid for coils)</p> <p>The coils are UL Recognized for the USA and Canada according to:</p> <ul style="list-style-type: none"> • UL 429 (electrically operated valves) • CAN/CSA-C22.2 No. 139
	<p>Optional: UL Hazardous Locations – Explosion Protection (valid for coils)</p> <p>UL Listed for Hazardous Locations for USA and Canada</p> <p>Class I, Zone 1 Class I, Division 2, Group A, B, C and D Class II + III, Division 2, Group F and G</p>
	<p>Optional: FM (Factory Mutual) – Explosion Protection (valid for coils)</p> <p>FM for Hazardous Locations for USA and Canada</p> <p>Class I, Zone 1 Class I, Division 1, Groups A, B, C and D Class II + III, Division 1, Groups E, F and G</p>

DTS 1000395477 EN Version: D Status: RL (released | freigegeben | valide) printed: 15.01.2024

4. Materials

4.1. Bürkert resistApp



Bürkert resistApp – Chemical resistance chart

You want to ensure the reliability and durability of the materials in your individual application case? Verify your combination of media and materials on our website or in our resistApp.

[Start chemical resistance check](#)

4.2. Material specifications

Standard and vacuum version

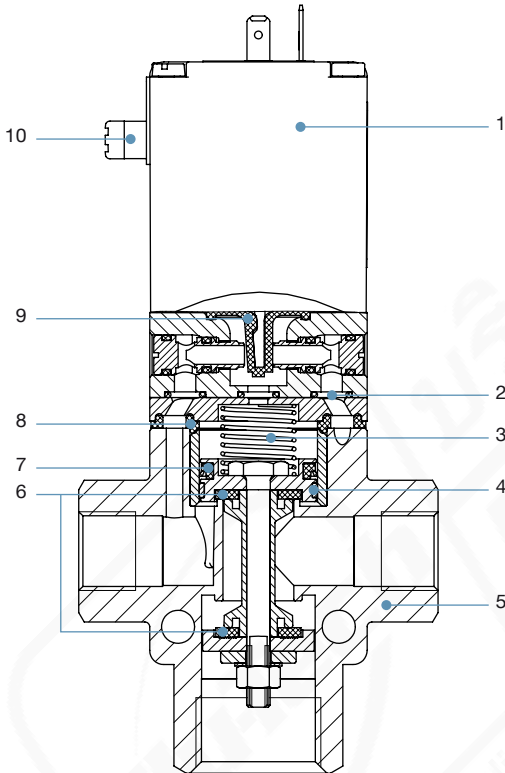

No.	Element	Material
1	Coil	Epoxy
2	O-rings	NBR, FKM, EPDM
3	Spring ^{1.)}	Stainless steel 1.4310
4	Piston ring	PTFE
5	Housing	Brass, gunmetal
6	Seat seal	NBR, PUR, FKM, EPDM
7	Piston seal	NBR, FKM, EPDM
8	Seal	NBR, FKM, EPDM
9	Diaphragm	NBR, FKM, EPDM
10	Manual override	PA

1.) Only for the vacuum version

External air controlled version

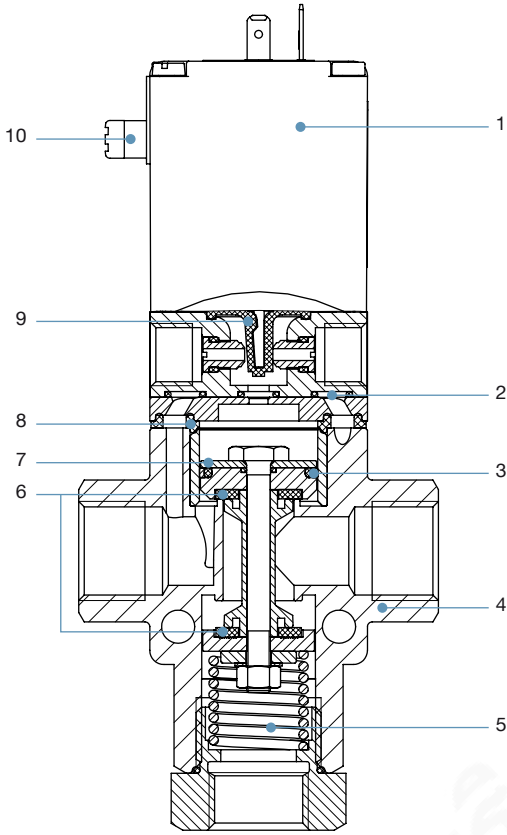

No.	Element	Material
1	Coil	Epoxy
2	O-rings	NBR, FKM, EPDM
3	Piston ring	PTFE
4	Housing	Brass, gunmetal
5	Spring	Stainless steel 1.4310
6	Seat seal	NBR, PUR, FKM, EPDM
7	Piston seal	NBR, FKM, EPDM
8	Seal	NBR, FKM, EPDM
9	Diaphragm	NBR, FKM, EPDM
10	Manual override	PA

DTS 1000395477 EN Version: D Status: RL (released | freigegeben | validé) printed: 15.01.2024

5. Dimensions

5.1. Standard and vacuum version

Note:

- Dimensions in mm
- The dimensions A1, B1, E1 and F1 apply to G-threads.
- The dimensions A2, B2, E2 and F2 apply to NPT-threads.
- The figure shows the valve in circuit function C with ports P, R and A/B (manual override via port P).
In circuit function D, the manual override is located above port A/B.

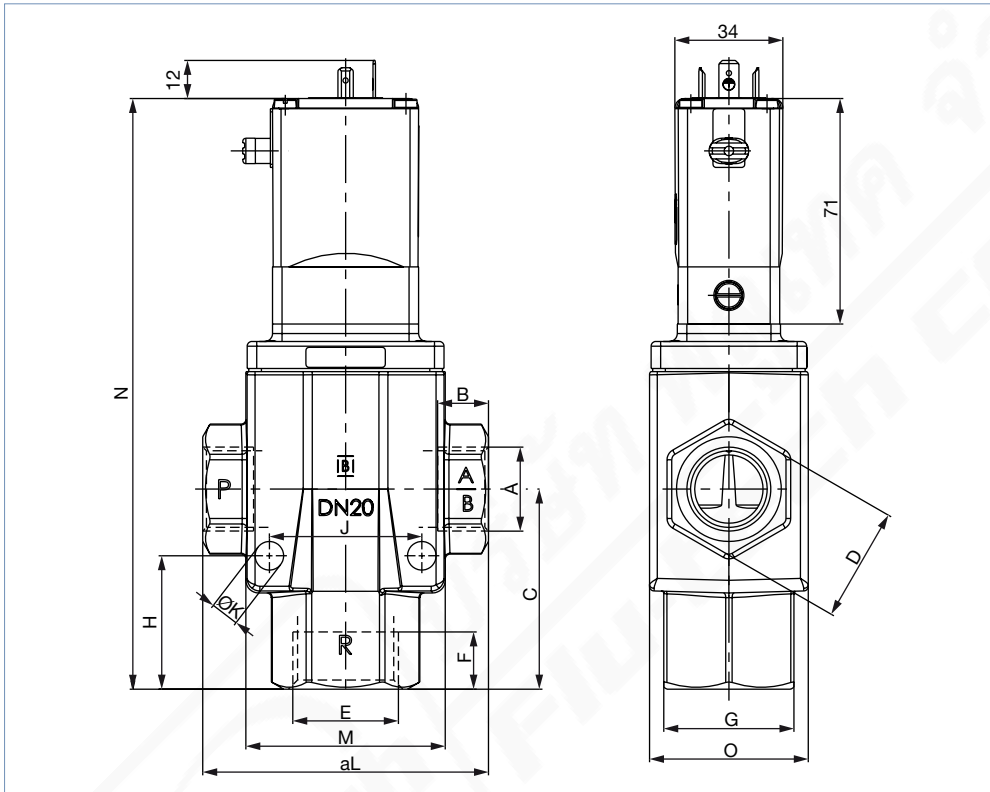

DN	A1	B1	A2	B2	C	D	E1	F1	E2	F2	G	H	J	K	L	M	N	O
8	G ¼	12	NPT ¼	10	34.5	SW22	G ¾	12	NPT ¾	10.3	SW22	23	30	7	65	46	124.8	33
12	G ½	14	NPT ½	13.7	47	SW27	G ¾	16	NPT ¾	14	SW32	31	34	7	76	46	150.5	33
20	G ¾	16	NPT ¾	14	63	SW36	G 1	18	NPT 1	16.8	SW41	42	48	9	90	63	186	50
25	G 1	18	NPT 1	16.8	74.5	SW41	G 1¼	20	NPT 1¼	17.3	54	44	66	9	110	82	210.5	60
40	G 1½	22.5	NPT 1½	17.3	104	SW55	G 2	26.5	NPT 2	17.6	78	65	93	13	153	117	264	88

Pilot valve configuration

Type 6430 WWC | Type 6430 WWD

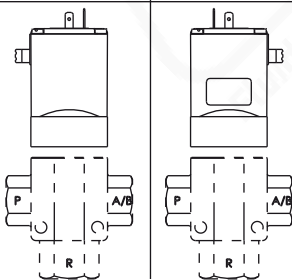

5.2. Vacuum version Low-Power

Note:

- Dimensions in mm
- The dimensions A1, B1, E1 and F1 apply to G-threads.
- The dimensions A2, B2, E2 and F2 apply to NPT-threads.
- The figure shows the valve in circuit function C with ports P, R and A/B (manual override via port A/B). In circuit function D, the manual override is located above port P.

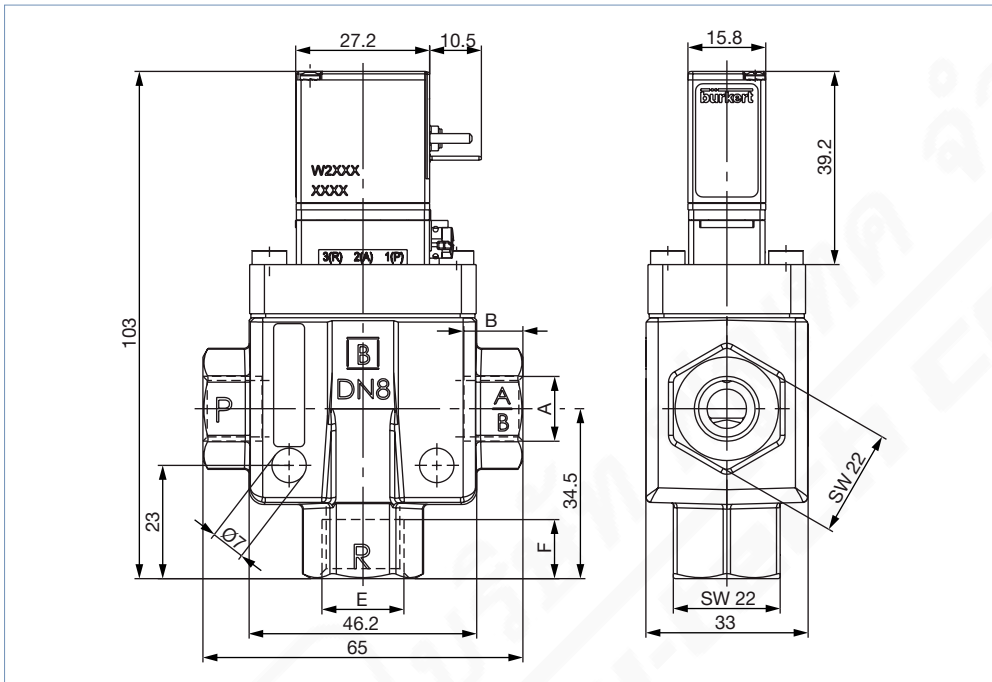

DN	A1	B1	A2	B2	E1	F1	E2	F2
8	G ¼	12	NPT ¼	10	G ⅝	12	NPT ⅝	10.3

Pilot valve configuration

Type 6430 WWC | Type 6430 WWD

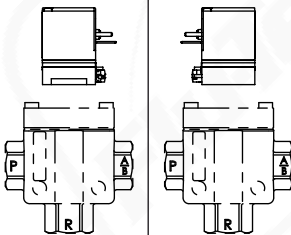

DTS 1000395477 EN Version: D Status: RL (released | freigegeben | validé) printed: 15.01.2024

Fluid Control Specialists

5.3. External air controlled version

Note:

- Dimensions in mm
- The dimensions A1, B1, E1 and F1 apply to G-threads.
- The dimensions A2, B2, E2 and F2 apply to NPT-threads.
- The figure shows the valve in circuit function C with ports P, R and A/B (manual override via port P).
In circuit function D, the manual override is located above port A/B.

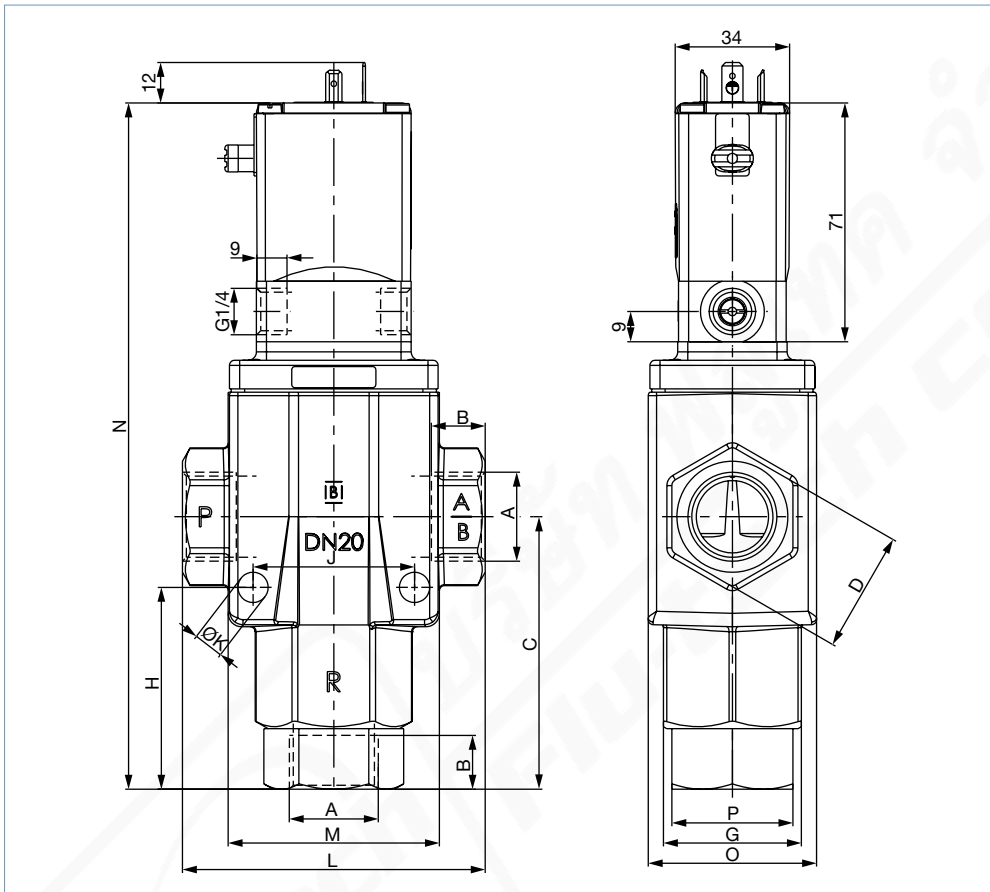

DN	A1	B1	A2	B2	C	D	G	H	J	K	L	M	N	O	P
8	G ¼	12	NPT ¼	10	47.5	SW22	SW22	36	30	7	65	46	137.8	33	SW19
12	G ½	14	NPT ½	13.7	59	SW27	SW32	43	34	7	76	46	162.5	33	SW32
20	G ¾	16	NPT ¾	14	81	SW36	SW41	60	48	9	90	63	204	50	SW36

Pilot valve configuration

Type 6430 WWC | Type 6430 WWD

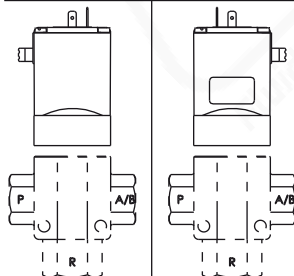

DTS 1000395477 EN Version: D Status: RL (released | freigegeben | validé) printed: 15.01.2024

5.4. ATEX/IECEX version

Note:

- Dimensions in mm
- The dimensions A1, B1, E1 and F1 apply to G-threads.
- The dimensions A2, B2, E2 and F2 apply to NPT-threads.

Cable version

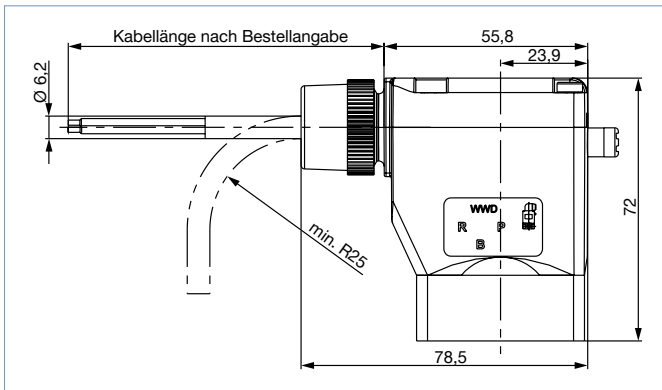

Terminal box version

Note:

The figure shows the valve in circuit function C with ports P, R and A/B (manual override via port P).
 In circuit function D, the manual override is located above port A/B.

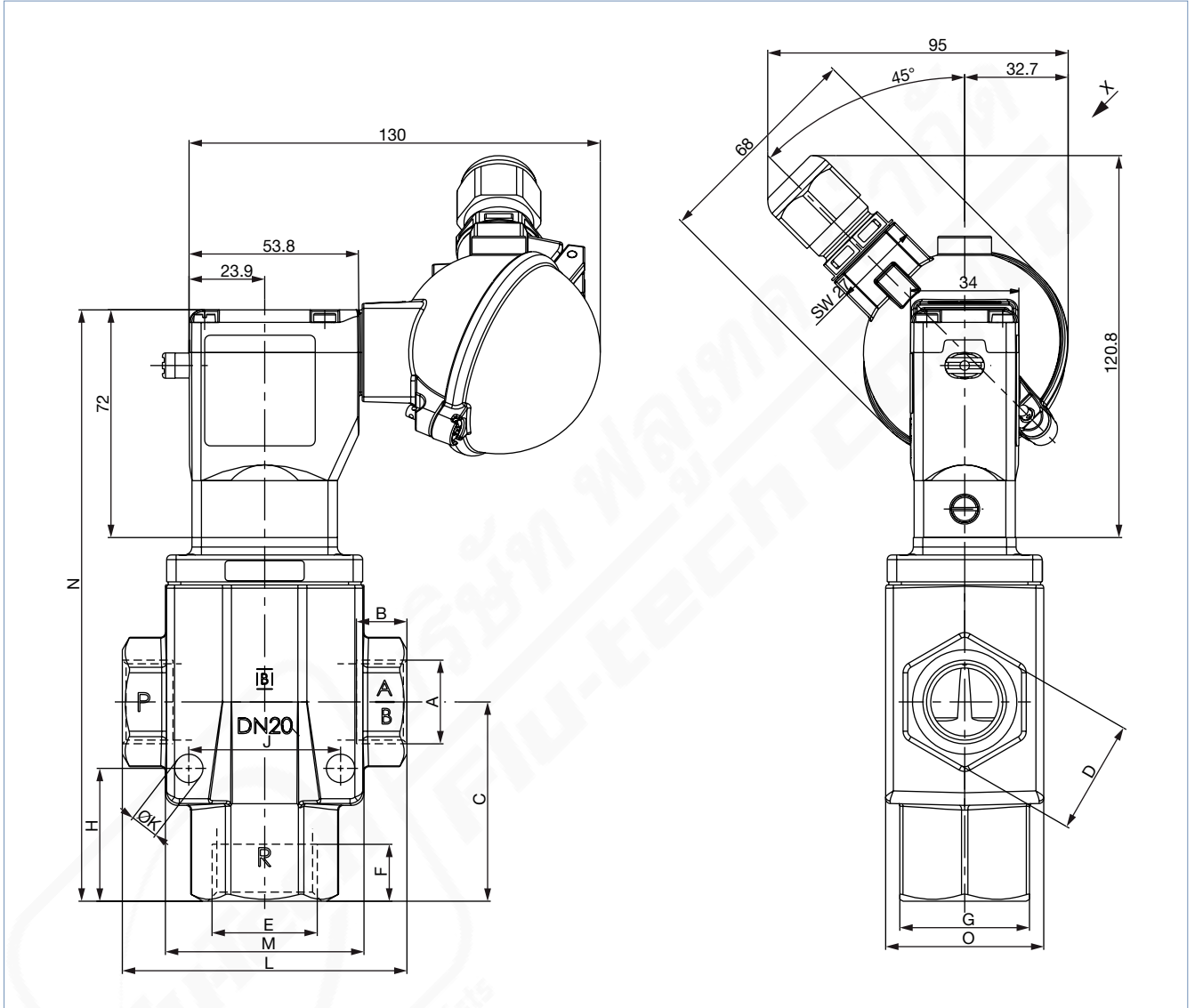

DTS 1000395477 EN Version: D Status: RL (released | freigegeben | valide) printed: 15.01.2024

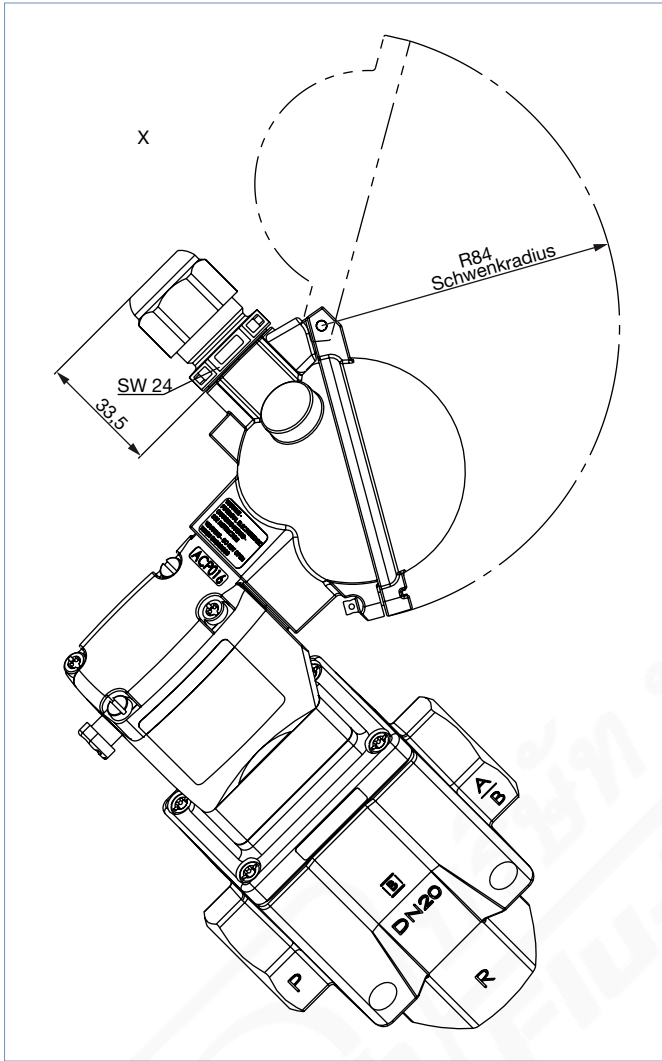

DN	A1	B1	A2	B2	C	D	E1	F1	E2	F2	G	H	J	K	L	M	N	O
8	G ¼	12	NPT ¼	10	34.5	SW22	G ¾	12	NPT ¾	10.3	SW22	23	30	7	65	46	124.8	33
12	G ½	14	NPT ½	13.7	47	SW27	G ¾	16	NPT ¾	14	SW32	31	34	7	76	46	150.5	33
20	G ¾	16	NPT ¾	14	63	SW36	G 1	18	NPT 1	16.8	SW41	42	48	9	90	63	186	50
25	G 1	18	NPT 1	16.8	74.5	SW41	G 1¼	20	NPT 1¼	17.3	54	44	66	9	110	82	210.5	60
40	G 1½	22.5	NPT 1½	17.3	104	SW55	G 2	26.5	NPT 2	17.6	78	65	93	13	153	117	264	88

Pilot valve configuration

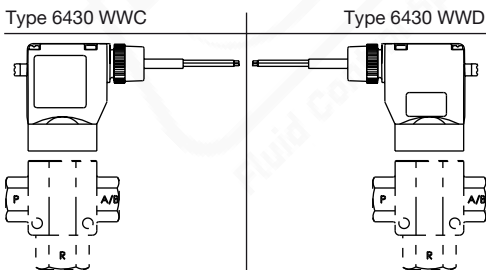

DTS 1000395477 EN Version: D Status: RL (released | freigegeben | valide) printed: 15.01.2024

6. Ordering information

6.1. Bürkert eShop



Bürkert eShop – Easy ordering and quick delivery

You want to find your desired Bürkert product or spare part quickly and order directly? Our online shop is available for you 24/7. Sign up and enjoy all the benefits.

[Order online now](#)

6.2. Bürkert product filter



Bürkert product filter – Get quickly to the right product

You want to select products comfortably based on your technical requirements? Use the Bürkert product filter and find suitable articles for your application quickly and easily.

[Try out our product filter](#)

6.3. Bürkert Product Enquiry Form

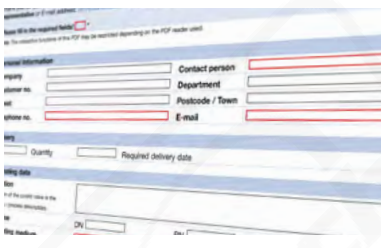

Bürkert Product Enquiry Form – Your enquiry quickly and compactly

Would you like to make a specific product enquiry based on your technical requirements? Use our Product Enquiry Form for this purpose. There you will find all the relevant information for your Bürkert contact. This will enable us to provide you with the best possible advice.

[Fill out the form now](#)

DTS 1000395477 EN Version: D Status: RL (released | freigegeben | validé) printed: 15.01.2024

6.4. Ordering chart

Standard version

Note:

- Please note that the cable plug must be ordered separately, see “Cable plug Type 2516, form C according to DIN EN 175301 - 803” on page 19 or separate data sheet Type 2518 ▶.
- Further versions are available on request.
- Valid for all articles in the following table: Body material brass (DN 25 and DN 40 gunmetal)

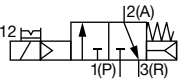
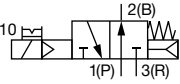
Circuit function	Port connection P and A/B	Orifice [mm]	K _v value water [m ³ /h] ^{1.)}	Pressure range [bar] ^{2.)}	Weight [kg]	Article no.		
						024/DC [V/Hz]	024/50 [V/Hz]	230/50 [V/Hz]
G-inner thread, seal material NBR (DN 12 seat seal PUR / external sealing NBR)								
CF C 3/2-way solenoid valve Servo-controlled, with manual override Normally closed 	G ¼	8	0.95	1...16	0.9	351164 ☒	357602 ☒	357604 ☒
	G ½	12	2.6	1...16	1.1	351175 ☒	357609 ☒	357611 ☒
	G ¾	20	6.2	1...16	2.2	351235 ☒	357615 ☒	357617 ☒
	G 1	25	10.0	1...10	2.8	351241 ☒	357621 ☒	357622 ☒
	G 1 ½	40	22.8	1...10	6.1	351247 ☒	357623 ☒	357624 ☒
CF D 3/2-way solenoid valve Servo-controlled, with manual override Normally open 	G ¼	8	0.95	1...16	0.9	357601 ☒	357603 ☒	357605 ☒
	G ½	12	2.6	1...16	1.1	357608 ☒	357610 ☒	357612 ☒
	G ¾	20	6.2	1...16	2.2	357614 ☒	357616 ☒	357618 ☒
	G 1	25	10.0	1...10	2.8	357619 ☒	o. r.	364298 ☒
	G 1 ½	40	22.8	1...10	6.1	364302 ☒	o. r.	364299 ☒

o. r. = on request

1.) Measurement at +20 °C, 1 bar at the valve inlet and free outlet

2.) Pressure data: overpressure to atmospheric pressure

Standard version as impulse valve

Note:

Valid for all articles in the following table: Body material brass (DN 25 and DN 40 gunmetal)

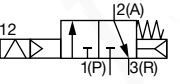
Circuit function	Port connection P and A/B	Orifice [mm]	K _v value water [m ³ /h] ^{1.)}	Pressure range [bar] ^{2.)}	Weight [kg]	Article no.	
						024/DC [V/Hz]	024/50 [V/Hz]
G-inner thread, seal material NBR (DN 12 seat seal PUR / external seal NBR)							
CF C 3/2-way impulse solenoid valve Servo-controlled 	G ¼	8	0.95	1...16	0.9	357606 ☒	o. r.
	G ½	12	2.6	1...16	1.1	357613 ☒	o. r.
	G ¾	20	6.2	1...16	2.2	o. r.	o. r.
	G 1	25	10.0	1...10	2.8	o. r.	o. r.
	G 1 ½	40	22.8	1...10	6.1	o. r.	o. r.

o. r. = on request

1.) Measurement at +20 °C, 1 bar at the valve inlet and free outlet

2.) Pressure data: overpressure to atmospheric pressure

DTS 1000395477 EN Version: D Status: RL (released | freigegeben | valide) printed: 15.01.2024

Vacuum version

Note:

- Please note that the cable plug must be ordered separately, see “Cable plug Type 2516, form C according to DIN EN 175301 - 803” on page 19 or separate data sheet **Type 2518** ▶.
- Please note that the vacuum version requires a minimum pressure difference of 0.5 bar and that it is only suitable for rough vacuum (atmospheric pressure (1013 hPa) to 100 Pa (1 mbar)).
- Further versions are available on request.
- Valid for all articles in the following table: Body material brass (DN 25 and DN 40 gunmetal)

Circuit function	Port connection P and A/B	Orifice [mm]	K _v value water [m ³ /h] ^{1.)}	Pressure range [bar] ^{2.)3.)}	Weight [kg]	Article no.	
						024/DC [V/Hz]	024/50 [V/Hz]
G-inner thread, seal material NBR							
CF C 3/2-way solenoid valve Servo-controlled, with manual override Normally closed 	G ¼	8	0.95	Vacuum up to 3	0.9	351169 ☒	357628 ☒
	G ½	12	2.6	Vacuum up to 3	1.1	351179 ☒	357631 ☒
	G ¾	20	6.2	Vacuum up to 3	2.2	351237 ☒	357634 ☒
	G 1	25	10.0	Vacuum up to 3	2.8	351243 ☒	357637 ☒
	G 1 ½	40	22.8	Vacuum up to 3	6.1	351249 ☒	o. r.
CF D 3/2-way solenoid valve Servo-controlled, with manual override Normally open 	G ¼	8	0.95	Vacuum up to 3	0.9	357627 ☒	357629 ☒
	G ½	12	2.6	Vacuum up to 3	1.1	357630 ☒	357632 ☒
	G ¾	20	6.2	Vacuum up to 3	2.2	357633 ☒	357635 ☒
	G 1	25	10.0	Vacuum up to 3	2.8	357636 ☒	357638 ☒
	G 1 ½	40	22.8	Vacuum up to 3	6.1	o. r.	o. r.

o. r. = on request
 1.) Measurement at +20 °C, 1 bar at the valve inlet and free outlet
 2.) Pressure data: overpressure to atmospheric pressure
 3.) A minimum differential pressure of 0.5 bar is required for switching.

Vacuum version as impulse valve

Note:

Valid for all articles in the following table: Body material brass (DN 25 and DN 40 gunmetal)

Circuit function	Port connection P and A/B	Orifice [mm]	K _v value water [m ³ /h] ^{1.)}	Pressure range [bar] ^{2.)3.)}	Weight [kg]	Article no.	
						024/DC [V/Hz]	024/50 [V/Hz]
G-inner thread, seal material NBR							
CF C 3/2-way impulse solenoid valve Servo-controlled 	G ¼	8	0.95	Vacuum up to 3	0.9	357639 ☒	o. r.
	G ½	12	2.6	Vacuum up to 3	1.1	357640 ☒	o. r.
	G ¾	20	6.2	Vacuum up to 3	2.2	357641 ☒	o. r.
	G 1	25	10.0	Vacuum up to 3	2.8	357642 ☒	o. r.
	G 1 ½	40	22.8	Vacuum up to 3	6.1	357643 ☒	o. r.

o. r. = on request
 1.) Measurement at +20 °C, 1 bar at the valve inlet and free outlet
 2.) Pressure data: overpressure to atmospheric pressure
 3.) A minimum differential pressure of 0.5 bar is required for switching.

DTS 1000395477 EN Version: D Status: RL (released | freigegeben | valide) printed: 15.01.2024

Vacuum version Low-Power

Note:

- Please note that the cable plug must be ordered separately, see “Cable plug Type 2516, form C according to DIN EN 175301 - 803” on page 19 or separate data sheet **Type 2516** ▶.
- Please note that the vacuum version requires a minimum pressure difference of 0.5 bar and that it is only suitable for rough vacuum (atmospheric pressure (1013 hPa) to 100 Pa (1 mbar)).
- Further versions are available on request.
- Valid for all articles in the following table: Body material brass (DN 25 and DN 40 gunmetal)

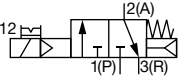
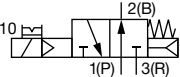
Circuit function	Port connection P and A/B	Orifice [mm]	K _v value water [m ³ /h] ¹⁾	Pressure range [bar] ^{2),3)}	Weight [kg]	Article no.
						024/DC [V/Hz]
G-inner thread, seal material NBR						
CF C 3/2-way solenoid valve Servo-controlled, with manual override Normally closed 	G ¼	8	0.95	Vacuum up to 1	0.6	357626
CF D 3/2-way solenoid valve Servo-controlled, with manual override Normally open 	G ¼	8	0.95	Vacuum up to 1	0.6	357625

1.) Measurement at +20 °C, 1 bar at the valve inlet and free outlet
 2.) Pressure data: overpressure to atmospheric pressure
 3.) A minimum differential pressure of 0.5 bar is required for switching.

DTS 1000395477 EN Version: D Status: RL (released | freigegeben | validé) printed: 15.01.2024

6.5. External air controlled version

Note

- Please note that the cable plug must be ordered separately, see “Cable plug Type 2518, form A according to DIN EN 175301 - 803” on page 19 or separate data sheet Type 2518 ▶.
- Please note that the version controlled by external air requires an auxiliary control air of at least 2 bar above the operating pressure.
- Further versions are available on request.
- Valid for all articles in the following table: Body material brass (DN 25 and DN 40 gunmetal)

Circuit function	Port connection P and A/B	Orifice	K _v value water	Pressure range	Weight	Article no.
		[mm]	[m ³ /h] ^{1.)}	[bar] ^{2.)3.)}	[kg]	024/DC [V/Hz]
G-inner thread, seal material NBR (DN 8 and DN 12 seat seal PUR / external seal NBR)						
CF C 3/2-way solenoid valve Servo-controlled, with auxiliary pilot air, with manual override Normally closed 	G ¼	8	0.95	Vacuum up to 8	0.9	351172 ☒
	G ½	12	2.6	Vacuum up to 8	1.1	351181 ☒
	G ¾	20	6.2	Vacuum up to 8	2.3	351239 ☒
CF D 3/2-way solenoid valve Servo-controlled, with auxiliary pilot air, with manual override Normally open 	G ¼	8	0.95	Vacuum up to 8	0.9	357644 ☒
	G ½	12	2.6	Vacuum up to 8	1.1	357645 ☒
	G ¾	20	6.2	Vacuum up to 8	2.3	357646 ☒

1.) Measurement at +20 °C, 1 bar at the valve inlet and free outlet
 2.) Pressure data: overpressure to atmospheric pressure
 3.) The external air-controlled version requires an auxiliary control air of at least 2 bar above the operating pressure.

Further versions on request	
Additional Electrical position feedback	Material • FKM • EPDM
Approval • cURus – coil approval • Pilot valve cURus (UL Recognized) • ATEX/IECEX	Voltage Further voltages on request
Process connection NPT	

DTS 1000395477 EN Version: D Status: RL (released | freigegeben | valide) printed: 15.01.2024

6.6. Ordering chart accessories

Cable plug Type 2516, form C according to DIN EN 175301 - 803

Note:

- Dimensions in mm
- Delivery of cable plug includes a flat seal and a fixing screw.
- For further versions see data sheet **Type 2516** ▶.

Cable plug	Dimensions	Version	Voltage	Article no.
		Without circuitry	0...250 V AC/DC	303141
		With LED	12...24 V AC/DC	303145
		With LED and varistor	12...24 V AC/DC	303148
		With rectifier, LED and varistor	12...24 V AC/DC	303142

Cable plug Type 2518, form A according to DIN EN 175301 - 803

Note:

- Dimensions in mm
- For further versions see data sheet **Type 2518** ▶.

Cable plug	Dimensions	Version	Voltage	Article no.
		Without circuitry (AC/DC)	0...250 V AC/DC	314802
		With LED (AC/DC)	12...24 V AC/DC	314812
		With LED and varistor (AC/DC)	12...24 V AC/DC	314820
		With rectifier, LED and varistor	12...24 V AC/DC	314816
		Without circuitry (AC/DC) with silicone seal for higher ambient temperature, e.g. steam version (NA07)	0...250 V AC/DC	361687

Threaded connection, reduction, cylindrical UNI-ISO 228/1

Reduction	Material	Max. nominal pressure [bar]	F	F1	L	Packaging unit	Article no.
					[mm]	[piece]	
	brass, nickel-plated	60	G 1/2	G 3/8	15.5	10	780140

DTS 1000395477 EN Version: D Status: RL (released | freigegeben | valide) printed: 15.01.2024