





### Digital electropneumatic positioner for the integrated mounting on process control valves

- Compact, robust stainless steel design
- Start-up by automatic TUNE-Function
- Contact-free position sensor
- Integrated control air routing
- Digital communication IO-Link, Bürkert system bus (bÜS)

Product variants described in the data sheet may differ from the product presentation and description.

#### Can be combined with

	<b>Type 2301</b> ▶ Pneumatically operated 2-way globe control valve
	<b>Type 2300</b> ▶ Pneumatically operated 2 way angle seat control valve ELEMENT
	<b>Type 2103</b> ▶ 2/2-way diaphragm valve with pneumatic stainless steel actuator (Type ELEMENT) for decentralised automation

#### Type description

Compact positioner for integrated mounting on pneumatically operated process valves. Remote setpoint adjustment via a 4-20 mA signal. A contact-free continuous sensor measures the position of the valve spindle. Simple installation through automatic TUNE-Function and setting through DIP-switch: close tight function, characteristic curves selection, reversal of effective direction, switching manual / automatic operation, digital input. A software interface can be used for, amongst others, linearisation of the operation characteristics by using free programmable fixed points. The valve position indication is shown through LED components. As an option an analogue position feedback can be integrated.

DTS 1000110889 EN Version: T Status: RL (released | freigegeben | validé) printed: 14.12.2023

**FLU-TECH CO. LTD.**

**Email:** sales@flutech.co.th **Website:** https://flutech.co.th

**Tel:** 02-384-6060, 086-369-5871-3 **Fax:** 02-384-5701 **LINE OA:** @flutech.co.th

**Address (HQ):** 845/3-4, Moo 3, Theparak Rd., T. Theparak, A. Mueang Samut Prakan, Samut Prakan, 10270, Thailand



## Table of contents

<b>1. General technical data</b>	<b>3</b>
1.1. Digital electropneumatic positioner Type 8696.....	3
1.2. Without fieldbus communication .....	4
1.3. With digital communication: IO-Link.....	5
1.4. With digital communication: Bürkert system bus (büS).....	5
<b>2. Approvals and conformities</b>	<b>6</b>
2.1. General notes.....	6
2.2. Conformity .....	6
2.3. Standards.....	6
2.4. Explosion protection .....	6
2.5. North America (USA/Canada) .....	6
2.6. Others .....	6
China Compulsory Certification (CCC) .....	6
<b>3. Materials</b>	<b>7</b>
3.1. Material specifications .....	7
<b>4. Dimensions</b>	<b>8</b>
4.1. Mounting on control valve ELEMENT Type 23xx / Type 2103 .....	8
4.2. Mounting on hygienic process valves of third party suppliers.....	8
<b>5. Device/Process connections</b>	<b>9</b>
5.1. Electrical connections.....	9
Without fieldbus communication 24 V DC.....	9
IO-Link connection.....	9
Bürkert system bus (büS) connection.....	9
<b>6. Performance specifications</b>	<b>10</b>
6.1. Signal flow diagram.....	10
Position control loop .....	10
Additional software functions of the TopControl Type 8696.....	10
6.2. Interface diagram .....	11
TopControl Positioner BASIC.....	11
<b>7. Product installation</b>	<b>12</b>
7.1. Combination options with pneumatic ELEMENT process valves.....	12
<b>8. Ordering information</b>	<b>13</b>
8.1. Bürkert eShop.....	13
8.2. Bürkert product filter.....	13
8.3. Ordering chart.....	13
8.4. Ordering chart accessories.....	14
Standard accessories .....	14
Adapter kits.....	14

DTS 1000110889 EN Version: T Status: RL (released | freigegeben | validé) printed: 14.12.2023

## 1. General technical data

### 1.1. Digital electropneumatic positioner Type 8696

Product properties	
Dimensions	Further information can be found in chapter "4. Dimensions" on page 8.
Material	
Body	PPS, Stainless steel
Seal	EPDM
Cover	PC
Operation	
Operating keys	2
DIP switch	Integrated (only for 24 V DC version without digital communication)
Service interface	Connection with PC via USB connection
Configuration tool	Bürkert Communicator PACTware (only for 24 V DC device version with serial interface)
Commissioning	
Initialisation positioner	Automatic by X.TUNE function (automatic adjustment of the positioner)
Manual override of pilot valve	In manual mode via operating keys
Status display	
Display of device and valve status	Multicoloured LEDs
Communication	
Digital	IO-Link, Bürkert system bus (bÜS) (based on CANopen)
Performance data	
Position sensor	
Measuring principle	Inductive
Position detection module	Contactless analogue position sensor (wear-free)
Stroke range	
Valve spindle	3...32 mm
Electrical data	
Operating voltage	24 V DC $\pm$ 25 % UL: NEC Class 2
Residual ripple	Max. 10 %
Power consumption	$\leq$ 3.5 W
Protection class	III according to DIN EN 61140
Electrical connection	
Multipole version	M12, 8-pin resp. 5-pin according to device version (see "5. Device/Process connections" on page 9)
Pneumatic data	
Control medium	
	Neutral gases, air, quality class according to ISO 8573 - 1
Dust content	Class 7 (< 40 $\mu$ m particle size)
Particle density	Class 5 (< 10 mg/m <sup>3</sup> )
Pressure dew point	Class 3 (< -20 °C)
Oil content	Class X (< 25 mg/ m <sup>3</sup> )
Supply pressure	0...7 bar <sup>1)</sup>
Pilot air port	Threaded connection G 1/8, stainless steel
Positioning system	
Low air capacity	
Single-acting	7 l <sub>N</sub> /min for aeration and ventilation (Q <sub>Nt</sub> value according to definition at pressure drop from 7 to 6 bar abs)
Actuator series/size	Type 23xx, actuator Ø 50 mm Type 2103, actuator Ø 50 mm

### Approvals and conformities

#### Explosion protection

Ignition protection class	II 3D Ex tc IIIC T135 °C Dc II 3G Ex ec IIC T4 Gc
ATEX	BVS 14 ATEX E 008 X II 3D Ex tc IIIC T135 °C Dc II 3G Ex ec IIC T4 Gc
IECEX	IECEX BVS 14.0009 X Ex tc IIIC T135 °C Dc Ex ec IIC T4 Gc

Further information can be found in chapter **"2.4. Explosion protection"** on page 6.

#### North America (USA/Canada)

UL Listed for the USA and Canada	cULus certificate: E238179 Further information can be found in chapter <b>"2.5. North America (USA/Canada)"</b> on page 6.
FM Explosion Protection	Increased Safety for Class I, Zone 2, AEx ec IIC T4 Gc hazardous (classified) locations, indoors and outdoors (IP54). Alternatively marked as Class I Division 2 Groups A, B, C, and D; T4. Further information can be found in chapter <b>"2.5. North America (USA/Canada)"</b> on page 6.

#### Others

China Compulsory Certification (CCC)	The products with Ex approval are suitable for import and use for hazardous applications in China. Further information can be found in chapter <b>"2.6. Others"</b> on page 6.
--------------------------------------	--

Further information can be found in chapter **"2. Approvals and conformities"** on page 6.

### Environment and installation

#### Operating conditions

Ambient temperature	- 10...+55 °C
Degree of protection	IP65/IP67 according to EN 60529, 4X according to NEMA 250 Standard
Operating altitude	Up to 2000 m above sea level

#### Installation and mechanical data

Installation variant	Direct mounting
Installation position	As required, preferably with actuator in upright position
Valve actuator (type, size)	ELEMENT actuator series Type 23xx/2103, actuator size Ø 50 mm and third-party actuators
Adapter kit	Further information can be found in chapter <b>"Adapter kits"</b> on page 14.

## 1.2. Without fieldbus communication

### Electrical data

Operating voltage	24 V DC ±25 %
Residual ripple	Max. 10 %
Protection class	III according to DIN EN 61140

### Input/Output

Digital input	1 digital input, 0...5 V = log "0", 10...30 V = log "1"
Analogue output	1 output (optional) 0/4...20 mA

### Input data setpoint

#### Setpoint signal

Setpoint value setting default	4...20 mA (0...20 mA adjustable via configuration software)
Input resistance	0/4...20 mA: 75 Ω

### 1.3. With digital communication: IO-Link

Electrical data	
IO-Link specification	V1.1
SIO mode	No
VendorID	0x0078, 120
DeviceID	See IODD file (The IODD file can be downloaded from our <a href="#">website Type 8696</a> ▶, see Software > Device Description Files)
Transmission rate	230.4 kbit/s (COM 3)
Data storage	Yes
Cable length	Max. 20 m
Port class	A and B
Electrical connection	M12×1, 5-pin, A-coded
Power supply	Via IO-Link
<b>Port Class A</b>	
Operating voltage	24 V DC ±25 % (according to specification)
Current consumption	Max. 150 mA
<b>Port Class B</b>	
<b>Operating voltage</b>	
System supply (Pin 1+3)	24 V DC ±25 % (according to specification)
Actuator supply (Pin 2+5)	24 V DC ±25 % (according to specification)
<b>Current consumption</b>	
System supply (Pin 1+3)	Max. 50 mA
Actuator supply (Pin 2+5)	Max. 120 mA

### 1.4. With digital communication: Bürkert system bus (būS)

Electrical data	
Operating voltage	18...30 V DC (according to specification)
Electrical connection	M12×1, 5-pin, A-coded
Current consumption	Max. 150 mA

## 2. Approvals and conformities

### 2.1. General notes

- The approvals and conformities listed below must be stated when making enquiries. This is the only way to ensure that the product complies with all required specifications.
- Not all available versions can be supplied with the below mentioned approvals or conformities.



### 2.2. Conformity

In accordance with the Declaration of Conformity, the product is compliant with the EU Directives.



### 2.3. Standards

The applied standards which are used to demonstrate compliance with the EU Directives are listed in the EU-Type Examination Certificate and/or the EU Declaration of Conformity.

### 2.4. Explosion protection

Approval	Description
 	<p><b>Optional: Explosion protection</b></p> <p><b>ATEX:</b>                      BVS 14 ATEX E 008 X                      II 3D Ex tc IIIC T135 °C Dc                      II 3G Ex ec IIC T4 Gc</p> <p><b>IECEX:</b>                      IECEX BVS 14.0009 X                      Ex tc IIIC T135 °C Dc                      Ex ec IIC T4 Gc</p>

### 2.5. North America (USA/Canada)

Approval	Description
	<p><b>Optional: UL Listed for the USA and Canada</b>                      The products are UL Listed for the USA and Canada according to:</p> <ul style="list-style-type: none"> <li>• UL 61010-1 (ELECTRICAL EQUIPMENT FOR MEASUREMENT, CONTROL, AND LABORATORY USE – Part 1: General Requirements)</li> <li>• CAN/CSA-C22.2 No. 61010-1</li> </ul>
	<p><b>Optional: FM (Factory Mutual) – Explosion Protection</b>                      Increased Safety for Class I, Zone 2, AEx ec IIC T4 Gc hazardous (classified) locations, indoors and outdoors (IP54). Alternatively marked as Class I Division 2 Groups A, B, C, and D; T4.</p>

### 2.6. Others

#### China Compulsory Certification (CCC)

Conformity	Description
	<p><b>Optional: China Compulsory Certification (CCC)</b>                      The products with Ex approval are suitable for import and use for hazardous applications in China.</p>

DTS 1000110889 EN Version: T Status: RL (released | freigegeben | valide) printed: 14.12.2023

### 3. Materials

#### 3.1. Material specifications

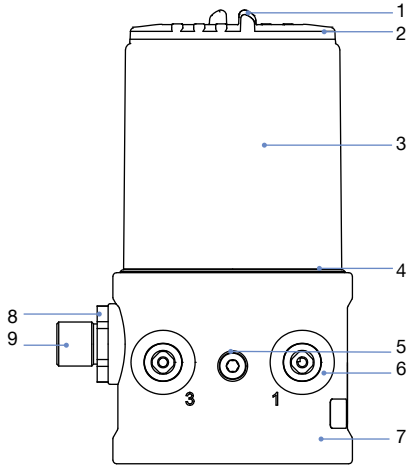

No.	Element	Material
1	Cover	PC
2	Seal	EPDM
3	Body casing	Stainless steel
4	Seal	EPDM
5	Screws	Stainless steel
6	Push-in connector Threaded ports G 1/8	POM/stainless steel Stainless steel
7	Basic housing	PPS
8	Screws	Stainless steel
9	Connector M12	Stainless steel





## 4. Dimensions

### 4.1. Mounting on control valve ELEMENT Type 23xx / Type 2103

**Note:**

- Dimensions in mm
- Internal control air supply to the actuator

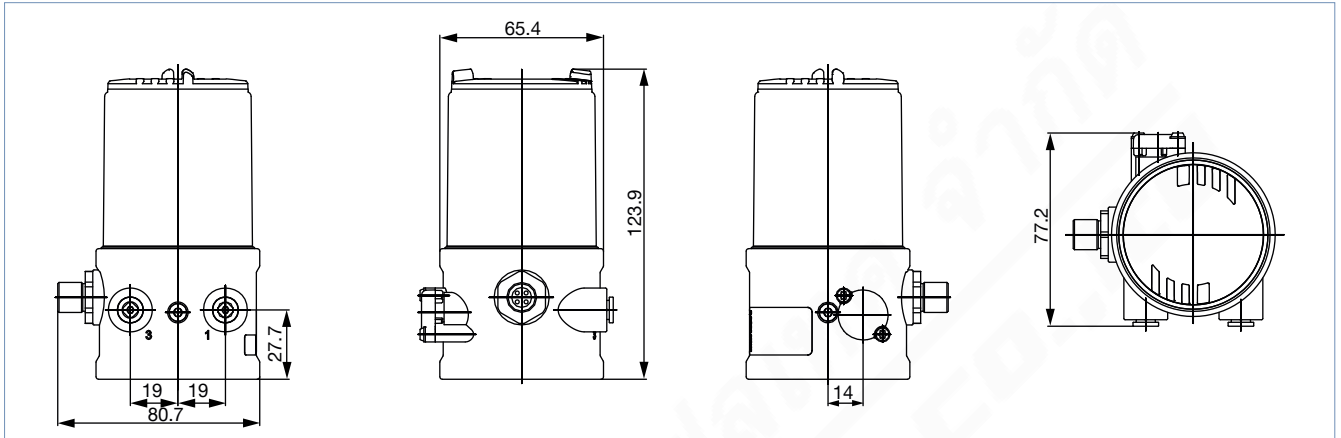

### 4.2. Mounting on hygienic process valves of third party suppliers

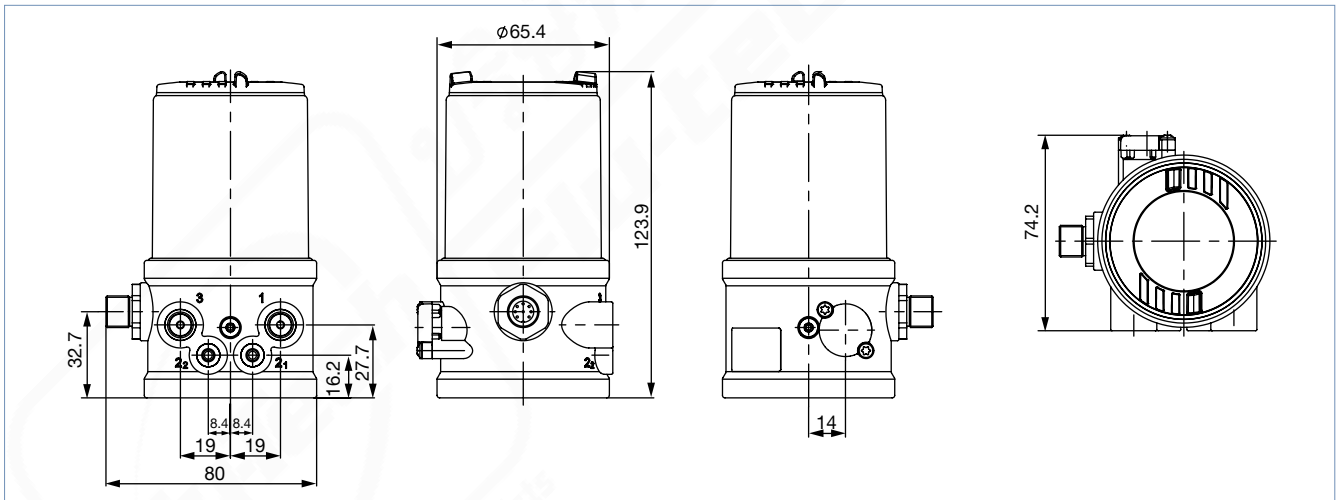

DTS 1000110889 EN Version: T Status: RL (released | freigegeben | validé) printed: 14.12.2023



## 5. Device/Process connections

### 5.1. Electrical connections

Without fieldbus communication 24 V DC

M12 circular plug, 8-pin																			
	<table border="1"> <thead> <tr> <th>Pin</th> <th>Pin assignment</th> </tr> </thead> <tbody> <tr> <td>1</td> <td>Setpoint + (0/4...20 mA / 0...5/10 V)</td> </tr> <tr> <td>2</td> <td>Setpoint GND</td> </tr> <tr> <td>3</td> <td>Operating voltage GND</td> </tr> <tr> <td>4</td> <td>Operating voltage +24 V DC</td> </tr> <tr> <td>5</td> <td>Digital input +</td> </tr> <tr> <td>6</td> <td>Digital input GND</td> </tr> <tr> <td>7</td> <td>Analogue position feedback GND</td> </tr> <tr> <td>8</td> <td>Analogue position feedback +</td> </tr> </tbody> </table>	Pin	Pin assignment	1	Setpoint + (0/4...20 mA / 0...5/10 V)	2	Setpoint GND	3	Operating voltage GND	4	Operating voltage +24 V DC	5	Digital input +	6	Digital input GND	7	Analogue position feedback GND	8	Analogue position feedback +
	Pin	Pin assignment																	
	1	Setpoint + (0/4...20 mA / 0...5/10 V)																	
	2	Setpoint GND																	
	3	Operating voltage GND																	
	4	Operating voltage +24 V DC																	
	5	Digital input +																	
	6	Digital input GND																	
7	Analogue position feedback GND																		
8	Analogue position feedback +																		

### IO-Link connection

M12 circular plug, 5-pin, Port Class A				
	Pin	Description	Pin assignment	
	1	L +	24 V DC	System supply
	2	I/Q	NC	Not connected
	3	L -	0 V (GND)	System supply
	4	C/Q	IO-Link	Communication
5	NC	NC	Not connected	

M12 circular plug, 5-pin, Port Class B				
	Pin	Description	Pin assignment	
	1	L +	24 V DC	System supply
	2	P24	24 V DC	Actuator supply
	3	L -	0 V (GND)	System supply
	4	C/Q	IO-Link	Communication
5	N24	0 V (GND)	Actuator supply	

### Bürkert system bus (būS) connection

M12 circular plug, 5-pin			
	Pin	Description	Cable colour
	1	CAN shielding	CAN shielding
	2	+24 V DC ±25 %, max. residual ripple 10 %	Red
	3	GND / CAN_GND	Black
	4	CAN_H	White
5	CAN_L	Blue	

DTS 1000110889 EN Version: T Status: RL (released | freigegeben | validé) printed: 14.12.2023

## 6. Performance specifications

### 6.1. Signal flow diagram

#### Position control loop

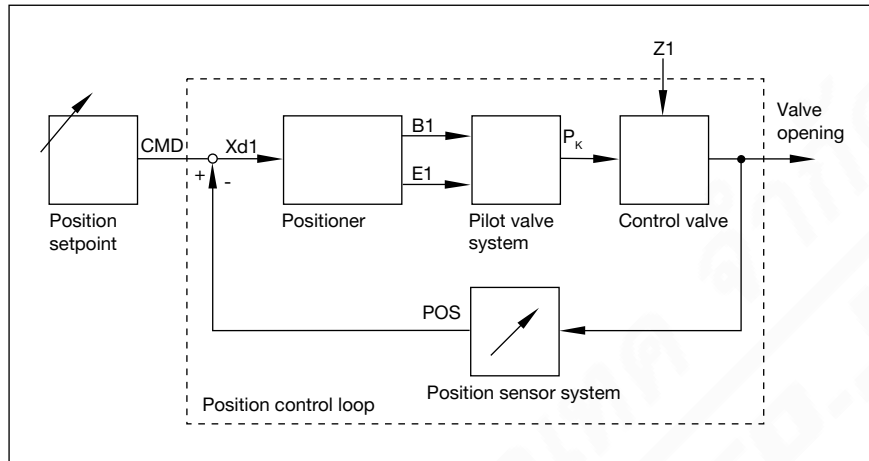

#### Additional software functions of the TopControl Type 8696

##### TopControl BASIC functions

- Automatic commissioning of control valve system
- Digital input (safety position)
- Analogue position feedback (optional)

##### DIP switch activated device

- Close-tight function
- Inversion of operating direction of the setpoint signal
- Linear characteristic curves selection or customised programming (software interface)
- Manual and automatic operation

##### Communication software with activatable and parameter driven functions

- Customised programming transmission characteristics
- Choices of setpoint signal
- Range splitting setpoint signal
- Limitation of stroke range
- Limitation of the actuating speed
- Safety position
- Signal fault detection

## 6.2. Interface diagram

### TopControl Positioner BASIC

#### Without fieldbus communication 24 V DC

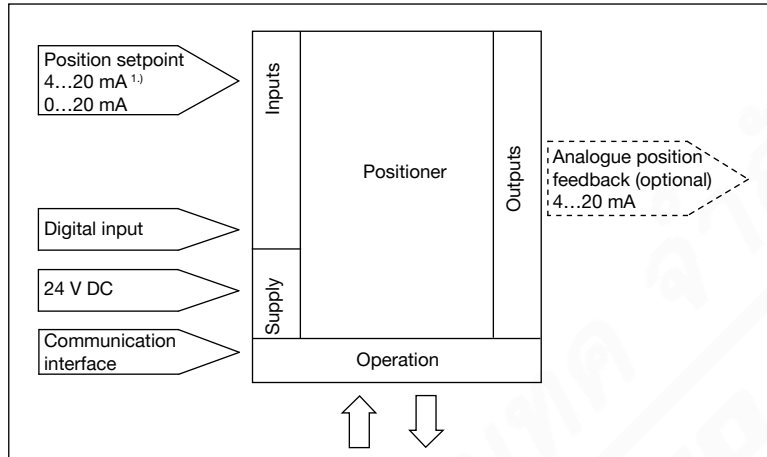

1.) Default setting

#### Version with fieldbus communication AS-Interface, IO-Link and Bürkert system bus (bÜS)

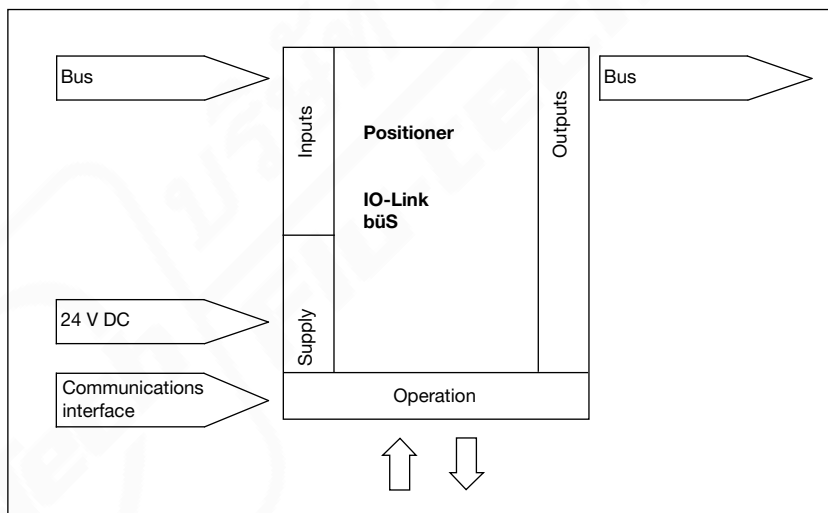

## 7. Product installation

### 7.1. Combination options with pneumatic ELEMENT process valves

**Note:**

A **TopControl control valve system** consists of a **BASIC positioner Type 8691** and an **ELEMENT control valve Type 23xx** resp. **Type 2103**, actuator size 50 mm.

The following information is required to select a complete system:

- **Article no.** of the desired **positioners TopControl BASIC**, see **data sheet Type 8696**
- **Article no.** of the desired **control valve Type 23xx/2103**, see **data sheet Type 2301 ▶, Type 2300 ▶ and Type 2103 ▶**

You order two components and receive a completely assembled and certified valve.

#### Example of decentralised automation of On/Off ELEMENT valve systems



1.) See data sheet **Adaptations for third-party actuators Type KK01 ▶** or contact the appropriate Bürkert sales office.

DTS 1000110889 EN Version: T Status: RL (released | freigegeben | validé) printed: 14.12.2023

## 8. Ordering information

### 8.1. Bürkert eShop



**Bürkert eShop – Easy ordering and quick delivery**

You want to find your desired Bürkert product or spare part quickly and order directly? Our online shop is available for you 24/7. Sign up and enjoy all the benefits.

[Order online now](#)

### 8.2. Bürkert product filter



**Bürkert product filter – Get quickly to the right product**

You want to select products comfortably based on your technical requirements? Use the Bürkert product filter and find suitable articles for your application quickly and easily.

[Try out our product filter](#)

### 8.3. Ordering chart

**Note:**

- The adapter kits must be ordered separately, see **“Adapter kits” on page 14.**
- All standard versions are UL-approved.
- Other versions are available on request.

Circuit function Pilot valve system	Electrical connection	Communication	Analogue feedback	Digital input	Pilot air ports Threaded connection	Article no.	
						Standard	ATEX II Cat. 3G/D, IECEx, CCC <sup>1.)</sup>
<b>Actuator series ELEMENT Type 23xx/2103 with actuator size Ø 50 mm (internal control air routing)</b>							
Single-acting	M12 plug connector	Without fieldbus communication	–	Yes	G 1/8	326436	265082
			Yes	Yes	G 1/8	326437	265083
		IO-Link Port Class A	–	–	G 1/8	20032474	20032476
		IO-Link Port Class B	–	–	G 1/8	326447	o. r.
		Bürkert system bus (büS)	–	–	G 1/8	326445	o. r.
<b>Mounting on external drives (external control air routing)</b>							
Single-acting	M12 plug connector	Without fieldbus communication	–	Yes	G 1/8	326434	265084
			Yes	Yes	G 1/8	326435	265085
		IO-Link Port Class A	–	–	G 1/8	20032473	20032475
		IO-Link Port Class B	–	–	G 1/8	326446	o. r.
		Bürkert system bus (büS)	–	–	G 1/8	326444	o. r.

o. r. = on request

1.) CCC (China Compulsory Certificate) for device versions with Ex approval











DTS 1000110889 EN Version: T Status: RL (released | freigegeben | validé) printed: 14.12.2023

#### 8.4. Ordering chart accessories

##### Standard accessories

**Note:**

Must be ordered separately.

Description	Article no.
M12 circular socket with cable, 8-pin, cable length: 5 m, for input and output signals	919267 
Silencer G 1/8	780779 
Silencer 6 mm, PE, push-in connection	902662 
USB interface for serial communication	227093 
USB büS interface set 2 (Type 8923) for connection to the Bürkert Communicator software: including büS stick, connection cable to M12 plug, M12 connection cable on micro USB for the büS service interface and Y distributor, cable length: 0.7 m	772551 
büS cable extension, M12, cable length: 1 m	772404 
büS cable extension, M12, cable length: 3 m	772405 
büS cable extension, M12, cable length: 5 m	772406 
büS cable extension, M12, cable length: 10 m	772407 
Sensor puck (spare part)	677245 
Software Bürkert Communicator	<b>Type 8920</b> 

##### Adapter kits

**Note:**

Must be ordered separately.

Adapter kits for third-party actuators can be found in the **data sheet Adaptation for third-party actuators Type KK01**  or contact the appropriate Bürkert sales office.

Description	Actuator size	Control function	Article no.
Attachment kit for Type 21xx/23xx actuator series	Ø 50 mm	Universal	679918 