



Servo-assisted 2/2-way diaphragm valve

- Servo-assisted diaphragm with diameter of up to DN 50
- Vibration-proof, central screwed coil system
- Damped design for quiet closing
- Energy-saving double coil technology with kick and drop variant
- Explosion-proof versions

Product variants described in the data sheet may differ from the product presentation and description.

Can be combined with



Type 2518
Cable plug,
form A according to
DIN EN 175301 - 803



Type 2509
Cable plug,
form A according to
DIN EN 175301 - 803

Type description

The 6281 valve is a servo-assisted solenoid valve of the S.EV series. A minimum differential pressure is always required for the function of the valve. Various diaphragm material combinations and methods of operation are available depending on the application. The standard brass housing satisfies all European drinking water requirements. Dezincification-resistant brass is available for other markets. The housing offering is rounded out by a stainless steel version. To reduce power consumption in operation, coils with "Kick and Drop" (KD) electronics assembly (double coil technology) are available. The valve can be equipped with manual override for easy maintenance and commissioning. NEMA 4X is available on request.



Table of contents

1. General technical data	3
2. Circuit functions	4
3. Approvals and conformities	4
3.1. General notes.....	4
3.2. Conformity	4
3.3. Standards.....	4
3.4. Explosion protection	4
3.5. North America (USA/Canada)	5
3.6. Drinking water	5
3.7. Others	5
DNV GL classification	5
4. Materials	6
4.1. Bürkert resistApp	6
4.2. Material specifications	6
5. Dimensions	7
5.1. Standard version.....	7
5.2. Coil UL Listed (cULus) for hazardous locations, Class I, Division 2	9
6. Performance specifications	12
6.1. Power consumption	12
6.2. Power consumption Kick and Drop coil.....	12
7. Product accessories	12
7.1. Cable glands for ATEX/IECEx terminal box	12
7.2. Special tool to turn the terminal box.....	13
8. Ordering information	13
8.1. Bürkert eShop.....	13
8.2. Bürkert product filter	13
8.3. Bürkert Product Enquiry Form	13
8.4. Ordering chart.....	14
Standard version with brass body	14
Standard version with stainless steel body.....	17
Coil UL Listed (cULus) for hazardous locations, Class I, Division 2, electrical connection with 3 m cable.....	19
8.5. Ordering chart accessories.....	20
Cable plug Type 2518, form A according to DIN EN 175301 - 803	20
Cable plug Type 2509, form A according to DIN EN 175301 - 803	20
Cable glands for ATEX/IECEx terminal box	21
Mounting set for DN 10.....	21

1. General technical data

Product properties	
Dimensions	Further information can be found in chapter "5. Dimensions" on page 7.
Material	
Seal	NBR, EPDM, FKM
Body	Brass CW617N, stainless steel (dezincification resistant on request)
Inner valve parts	Stainless steel, Brass, Plastic (PPS)
Orifice	DN 10...DN 50
Circuit function	Further information can be found in chapter "2. Circuit functions" on page 4.
Thermal insulation class of solenoid coil	Epoxy coil class H
Performance data	
Duty cycle	100 % continuous operation
Switching time ^{1.)}	Opening: 0.1...1.5 s Closing: 0.2...4 s
Electrical data	
Operating voltage	24 V/DC, 24 V/UC, 24 V/AC, 120 V/AC
Power consumption	Further information can be found in chapter "6. Performance specifications" on page 12.
Voltage tolerance	± 10 %
Medium data	
Operating medium	
NBR	Neutral fluids (e.g. compressed air, water)
EPDM	Oil and fat-free fluids, hot water, acetone, aqueous alkali solution
FKM	Hot air, per-solution, hot oils
Medium temperature	
NBR	+ 14 °F...+ 176 °F
EPDM	- 22 °F...+ 212 °F
FKM	+ 32 °F...+ 248 °F
Process/Port connection & communication	
Electrical connection	
Standard version	<ul style="list-style-type: none"> Cable plug Type 2518 ▶, form A according to DIN EN 175301 - 803 Further information can be found in chapter "Cable plug Type 2518, form A according to DIN EN 175301 - 803" on page 21. Cable plug Type 2509 ▶, form A according to DIN EN 175301 - 803 Further information can be found in chapter "Cable plug Type 2509, form A according to DIN EN 175301 - 803" on page 21.
Explosion-proof version	With moulded cable 3 m length, 3×0.5 mm ² with terminal box
Approvals and conformities	
Directives	CE, EAC
Degree of protection	IP65 with cable plug, IP67 with cable plug Type 2518 ▶ UL hazloc 2 with cable plug Type 2509 ▶ on request NEMA 4X with cable plug Type 2509 ▶ with stainless steel versions
Explosion protection	Further information can be found in chapter "3.4. Explosion protection" on page 4.
North America (USA/Canada)	Further information can be found in chapter "3.5. North America (USA/Canada)" on page 5.
Drinking water	Further information can be found in chapter "3.6. Drinking water" on page 5.
Environment and installation	
Installation	As required, preferably with actuator upright
Ambient temperature	Max. + 131 °F

1.) Measurement at +68 °F, 87 psi at the valve outlet, opening: pressure build-up 0...90 %, closing: pressure reduction 100...10 %

2. Circuit functions

Symbol	Description
	Circuit function A (CF A) 2/2-way solenoid valve Servo-controlled Normally closed
	Circuit function B (CF B) 2/2-way solenoid valve Servo-controlled Normally open

3. Approvals and conformities

3.1. General notes

- The approvals and conformities listed below must be stated when making enquiries. This is the only way to ensure that the product complies with all required specifications.
- Not all available versions can be supplied with the below mentioned approvals or conformities.

3.2. Conformity

In accordance with the Declaration of Conformity, the product is compliant with the EU Directives.

3.3. Standards

The applied standards which are used to demonstrate compliance with the EU Directives are listed in the EU-Type Examination Certificate and/or the EU Declaration of Conformity.

3.4. Explosion protection

Approval	Description
	Optional: Explosion protection ATEX: EPS 18 ATEX 1232 X II 2G Ex mb IIC T4 Gb II 2D Ex mb IIIC T130 °C Db II 2G Ex eb mb IIC T4 Gb II 2D Ex mb tb IIIC T130 °C Db IECEX: IECEx EPS 18.0110 X Ex mb IIC T4 Gb Ex mb IIIC T130 °C Db Ex eb mb IIC T4 Gb Ex mb tb IIIC T130 °C Db

DTS 1000597993 EN Version: - Status: RL (released | freigegeben | valide) printed: 11.12.2023

3.5. North America (USA/Canada)

Approval	Description
	Valid for valves: UL Listed for the USA The valves are UL Listed for the USA according to: <ul style="list-style-type: none"> • UL 429 (electrically operated valves) and UL 429A (Electrically Operated Valves for Fire Protection Service)
	Valid for coils: UL Hazardous Locations – Explosion Protection UL Listed for Hazardous Locations for USA and Canada Class I, Zone 1 Class I, Division 2, Group A, B, C and D Class II + III, Division 2, Group F and G
	Valid for valves: UL Recognized for the USA The valves are UL Recognized for the USA according to: <ul style="list-style-type: none"> • UL 429 (electrically operated valves) and UL 429A (Electrically Operated Valves for Fire Protection Service)
	Valid for coils: UL Recognized for the USA and Canada The coils are UL Recognized for the USA and Canada according to: <ul style="list-style-type: none"> • UL 429 (electrically operated valves) • CAN/CSA-C22.2 No. 61010-1
	Valid for valves: CSA for Canada The valves are CSA approved for Canada according to: <ul style="list-style-type: none"> • CSA 139 (electrically operated valves)

3.6. Drinking water

Conformity	Description
	Suitable for use in drinking water applications The materials comply with the assessment principles (UBA) for materials in contact with drinking water (TrinkwasserV). PF39: Suitable for products with a maximum temperature of 85 °C (hot water) PF36: Suitable for products with a maximum temperature of 60 °C (warm water)

3.7. Others

DNV GL classification

Approval	Description
	DNV GL classification – Ships, offshore units, and high speed and light craft The products are accepted for installation on all vessels classed by DNV GL.

DTS 1000597993 EN Version: - Status: RL (released | freigegeben | validé) printed: 11.12.2023

4. Materials

4.1. Bürkert resistApp



Bürkert resistApp – Chemical resistance chart

You want to ensure the reliability and durability of the materials in your individual application case? Verify your combination of media and materials on our website or in our resistApp.

[Start chemical resistance check](#)

4.2. Material specifications

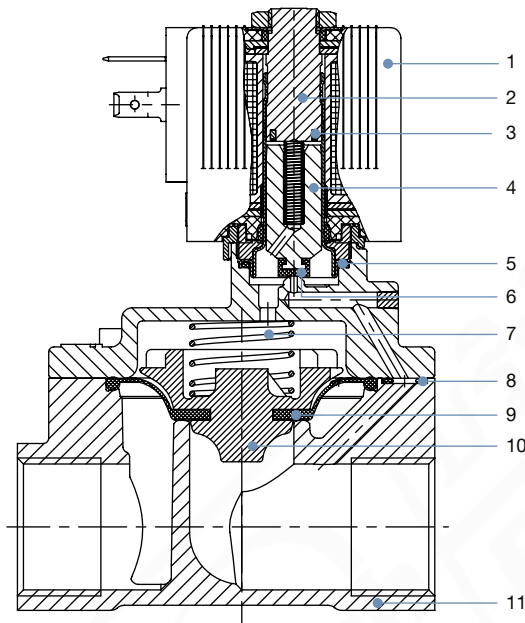

No.	Element	Material
1	Coil	Epoxy
2	Stopper	Stainless steel 1.4113
3	Shading ring	Cu (brass version) Ag (stainless steel version)
4	Magnetic core	Stainless steel 1.4113
5	O-rings	NBR, FKM, EPDM
6	Core seal	NBR, FKM, EPDM
7	Spring	Stainless steel 1.4310
8	O-rings	NBR, FKM, EPDM
9	Diaphragm	NBR, FKM, EPDM
10	Diaphragm holder	PPSGF40, DN 50: Brass and stainless steel
11	Valve body	Brass CW617N or stainless steel 1.4408 (CF8M)

5. Dimensions

5.1. Standard version

Note:

Dimensions in mm [inch]

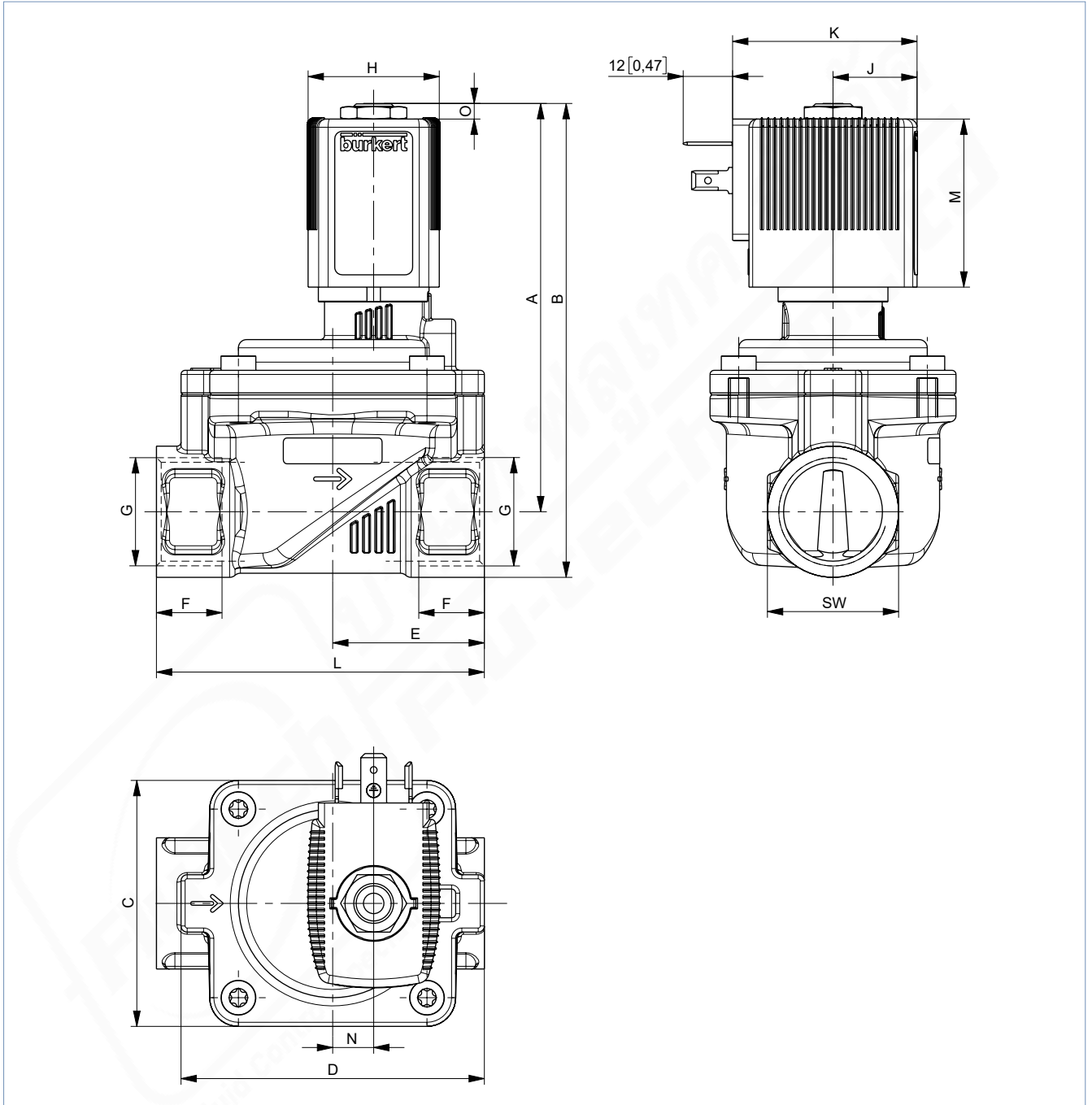

DTS 1000597993 EN Version: - Status: RL (released | freigegeben | validé) printed: 11.12.2023

Coil size	H		J		K		M		O	
	[mm]	[in]	[mm]	[in]	[mm]	[in]	[mm]	[in]	[mm]	[in]
5	32	1.26	20.5	0.81	45	1.77	41	1.61	3.4	0.13
6	40	1.57	23.5	0.93	51	2.01	41.4	1.63	3.8	0.15

Body material	DN	A		B		C		D		E		F		G [Zoll]	L		SW		N	
		[mm]	[in]	[mm]	[in]	[mm]	[in]	[mm]	[in]	[mm]	[in]	[mm]	[in]		[mm]	[in]	[mm]	[in]	[mm]	[in]
Brass	10	83.1	3.27	94.1	3.70	32	1.26	44	1.73	22	0.87	10	0.39	NPT ¼	50	1.97	22	0.87	-	-
												10.3	0.41							
	13	91.1	3.59	104.6	4.12	42	1.65	54.5	2.15	32.5	1.28	13.7	0.54	NPT ½	65	2.56	27	1.06	-	-
	25	106.6	4.20	127.1	5.00	70	2.76	85	3.35	46	1.81	16.8	0.66	NPT 1	95	3.74	41	1.61	15	0.59
	40	125.6	4.94	155.6	6.13	99	3.90	114	4.49	61	2.40	17.3	0.68	NPT 1½	126	4.96	60	2.36	23	0.91
	50	119.9	4.72	154.9	6.10	115	4.53	132	5.20	82	3.23	17.6	0.69	NPT 2	164	6.46	70	2.76	37	1.46
Stainless steel	13	91.1	3.59	104.6	4.12	42	1.65	54.5	2.15	32.5	1.28	13.7	0.54	NPT ½	65	2.56	27	1.06	-	-
	25	106.6	4.20	127.1	5.00	70	2.76	85	3.35	46	1.81	16.8	0.66	NPT 1	95	3.74	41	1.61	15	0.59
40	125.6	4.94	155.6	6.13	99	3.90	114	4.49	61	2.40	17.3	0.68	NPT 1½	126	4.96	60	2.36	23	0.91	
																				131.6

DTS 1000597993 EN Version: - Status: RL (released | freigegeben | validé) printed: 11.12.2023



5.2. Coil UL Listed (cULus) for hazardous locations, Class I, Division 2

Note:

- Dimensions in mm [inch]
- For DN 10...DN 50

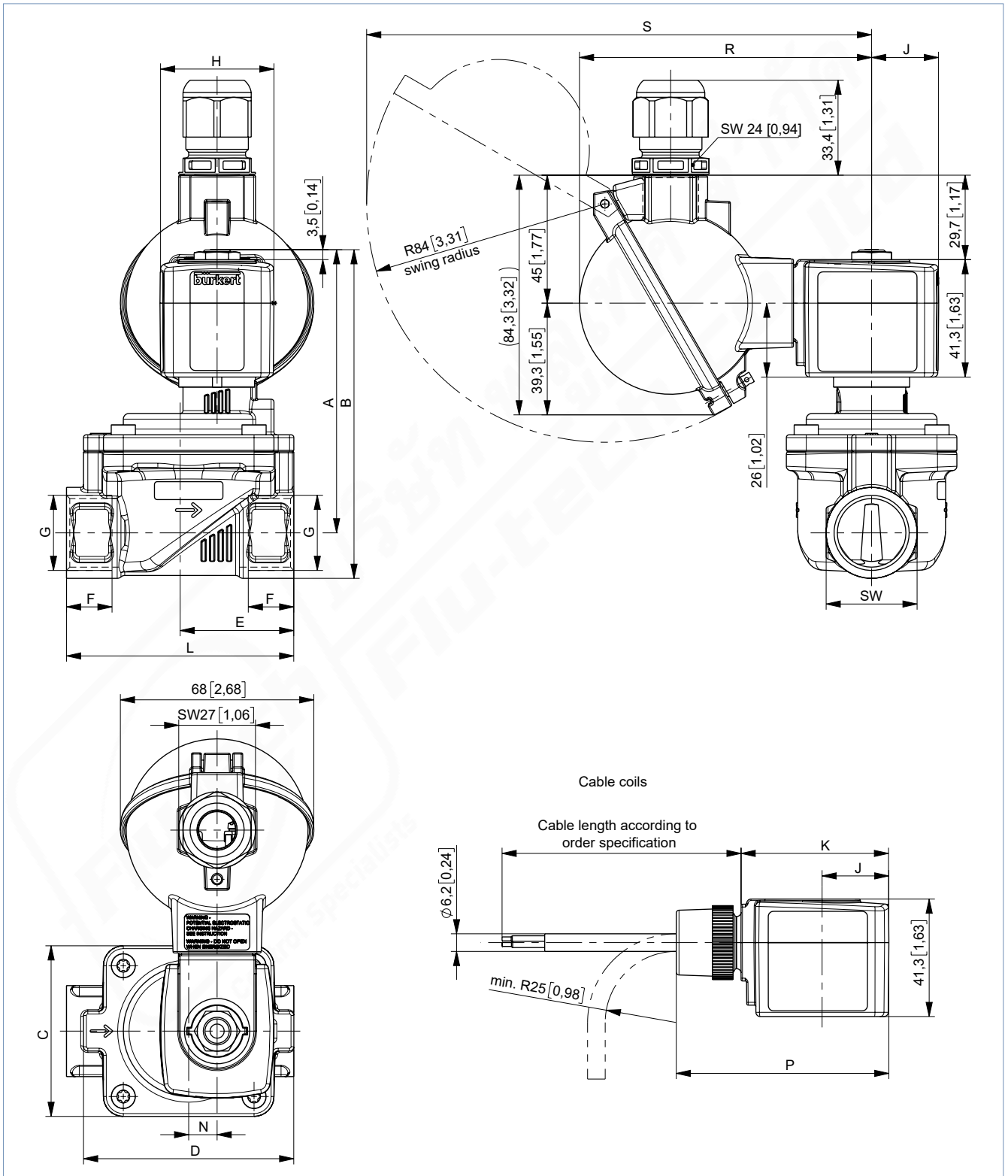

DTS 1000597993 EN Version: - Status: RL (released | freigegeben | valide) printed: 11.12.2023

Coil size	H		J		K		P		R		S	
	[mm]	[in]	[mm]	[in]	[mm]	[in]	[mm]	[in]	[mm]	[in]	[mm]	[in]
5	32	1.26	20.5	0.81	46	1.81	68.8	2.71	99.8	3.93	174.7	6.88
6	40	1.57	23.5	0.93	52	2.05	74.8	2.94	102.8	4.05	177.7	7.00

Body material	DN	A		B		C		D		E		F		G [Zoll]	L		SW		N		
		[mm]	[in]	[mm]	[in]	[mm]	[in]	[mm]	[in]	[mm]	[in]	[mm]	[in]		[mm]	[in]	[mm]	[in]	[mm]	[in]	
Brass	10	83.1	3.27	94.1	3.70	32	1.26	44	1.73	22	0.87	10	0.39	NPT ¼	50	1.97	22	0.87	-	-	
												10.3	0.41		NPT ⅜						
	13	91.1	3.59	104.6	4.12	42	1.65	54.5	2.15	32.5	1.28	13.7	0.54	NPT ½	65	2.56	27	1.06	-	-	
	20	99.6	3.92	115.6	4.55	60	2.36	74	2.91	37	1.46	14	0.55	NPT ¾	80	3.15	32	1.26	10	0.39	
	25	106.6	4.20	127.1	5.00	70	2.76	85	3.35	46	1.81	16.8	0.66	NPT 1	95	3.74	41	1.61	15	0.59	
			111.6	4.39	136.6	5.38							17.3	0.68	NPT 1¼			50	1.97		
	40	125.6	4.94	155.6	6.13	99	3.90	114	4.49	61	2.40	17.3	0.68	NPT 1½	126	4.96	60	2.36	23	0.91	
			131.6	5.18	166.6	6.56					64	2.52	17.6	0.69	NPT 2	132	5.20	70	2.76		
	50	119.9	4.72	154.9	6.10	115	4.53	132	5.20	82	3.23	17.6	0.69	NPT 2	164	6.46	70	2.76	37	1.46	
			119.6	4.71	162.1	6.38					89.5	3.52	23.6	0.93	NPT 2½	179	7.05	85	3.35		
Stainless steel	13	91.1	3.59	104.6	4.12	42	1.65	54.5	2.15	32.5	1.28	13.7	0.54	NPT ½	65	2.56	27	1.06	-	-	
	20	99.6	3.92	115.6	4.55	60	2.36	74	2.91	37	1.46	14	0.55	NPT ¾	80	3.15	32	1.26	10	0.39	
	25	106.6	4.20	127.1	5.00	70	2.76	85	3.35	46	1.81	16.8	0.66	NPT 1	95	3.74	41	1.61	15	0.59	
			111.6	4.39	136.6	5.38							17.3	0.68	NPT 1¼			50	1.97		
	40	125.6	4.94	155.6	6.13	99	3.90	114	4.49	61	2.40	17.3	0.68	NPT 1½	126	4.96	60	2.36	23	0.91	
		131.6	5.18	166.6	6.56					64	2.52	17.6	0.69	NPT 2	132	5.20	70	2.76			

DTS 1000597993 EN Version: - Status: RL (released | freigegeben | validé) printed: 11.12.2023



Note:

- Dimensions in mm [inch]
- Terminal box alignment for DN 50

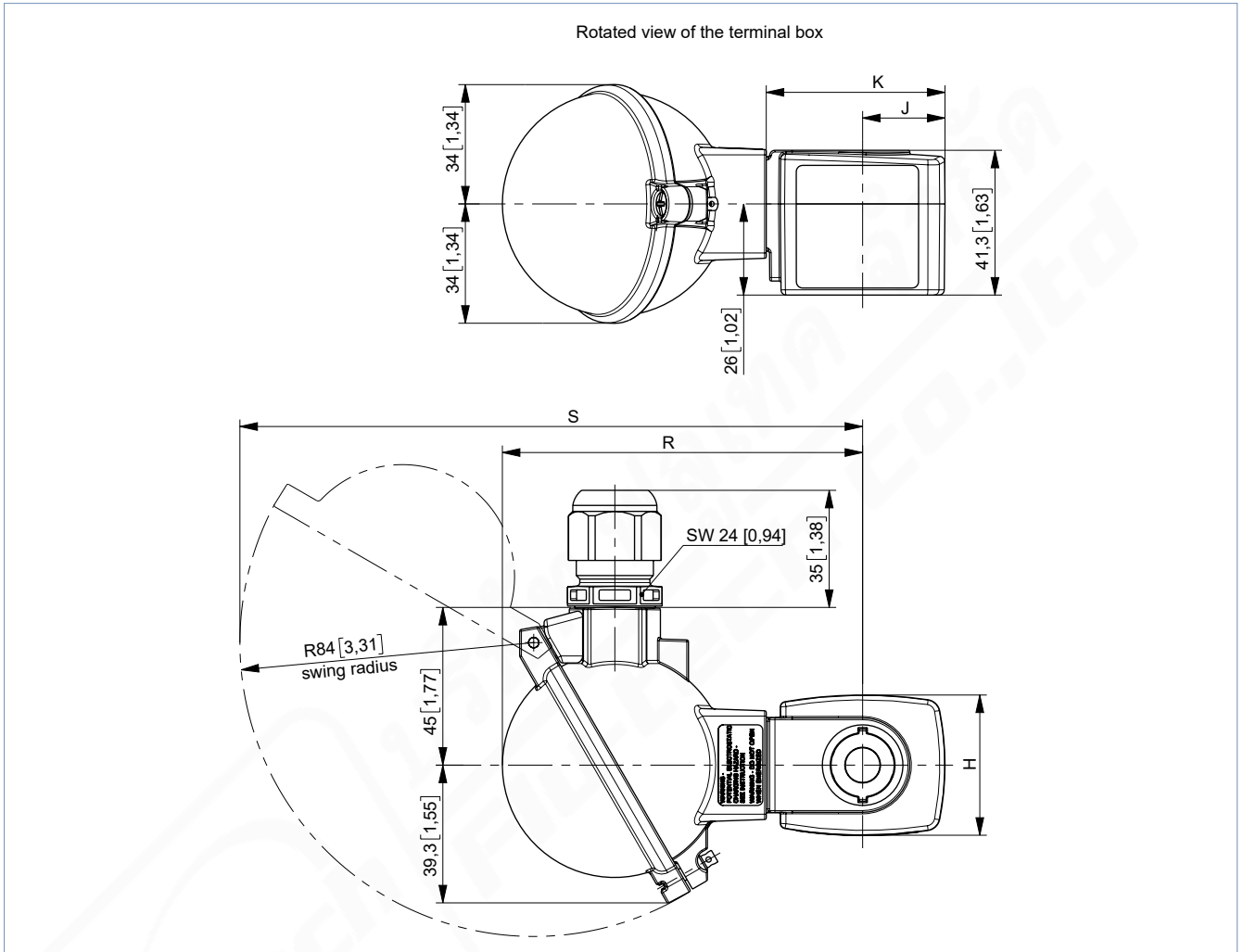

Coil size	H		J		K		P		R		S	
	[mm]	[in]	[mm]	[in]	[mm]	[in]	[mm]	[in]	[mm]	[in]	[mm]	[in]
5	32	1.26	20.5	0.81	46	1.81	68.8	2.71	99.8	3.93	174.7	6.88
6	40	1.57	23.5	0.93	52	2.05	74.8	2.94	102.8	4.05	177.7	7.00

DTS 1000597993 EN Version: - Status: RL (released | freigegeben | validé) printed: 11.12.2023

6. Performance specifications

6.1. Power consumption

Circuit function	Orifice [mm]	Coil size [mm]	AC			DC		EX AC/DC
			Inrush power [VA]	Holding power		Cold [W]	Hot [W]	Nominal power [W]
				[VA]	[VA]			
A	10...50	32	24	14	8	9.5	8	-
A	10...50	32	24	16	7	9.5	8	-
A / B	13...50	40	-	-	-	-	-	9
A	10	32	-	-	-	-	-	7
B	10	40	-	-	-	-	-	9

6.2. Power consumption Kick and Drop coil



Circuit function	Orifice [mm]	Coil size [mm]	Voltage [V]	Inrush power		Holding power [W]
				[VA]	[W]	
A	10...50	40	024/UC	-	12	0.6
A	10...50	40	230/56	20	-	2
B	10...50	40	024/UC	-	20	2
B	10...50	40	230/56	20	-	2

7. Product accessories

7.1. Cable glands for ATEX/IECEx terminal box

Note:

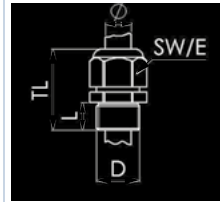
A polyamide cable gland is included in the scope of delivery. A nickel-plated brass version can be ordered for a surcharge, see **“Cable plug Type 2509, form A according to DIN EN 175301 - 803”** on page 21.

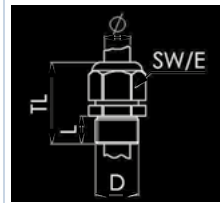
Description	Ex approvals		Dimensions										
	Certification	Identification											
Ex cable gland, Nickel-plated brass, 6...13 mm 	PTB 04 ATEX 1112 X, IECEx PTB 13.0027X	II 2 G Ex e IIC Gb, II 2 D Ex tb IIIC Db IP68	 <table border="1"> <tr><td>TL</td><td>29...37 mm</td></tr> <tr><td>L</td><td>6 mm</td></tr> <tr><td>D</td><td>20 mm</td></tr> <tr><td>SW</td><td>24 mm</td></tr> <tr><td>E</td><td>27 mm</td></tr> </table>	TL	29...37 mm	L	6 mm	D	20 mm	SW	24 mm	E	27 mm
TL	29...37 mm												
L	6 mm												
D	20 mm												
SW	24 mm												
E	27 mm												
Ex cable gland, Polyamide, 7...13 mm 	PTB 13 ATEX 1015 X, IECEx PTB 13.0034X	II 2 G Ex e IIC Gb, II 2 D Ex tb IIIC Db IP68	 <table border="1"> <tr><td>TL</td><td>36...45 mm</td></tr> <tr><td>L</td><td>10 mm</td></tr> <tr><td>D</td><td>20 mm</td></tr> <tr><td>SW</td><td>24 mm</td></tr> <tr><td>E</td><td>28 mm</td></tr> </table>	TL	36...45 mm	L	10 mm	D	20 mm	SW	24 mm	E	28 mm
TL	36...45 mm												
L	10 mm												
D	20 mm												
SW	24 mm												
E	28 mm												

DTS 1000597993 EN Version: - Status: RL (released | freigegeben | validé) printed: 11.12.2023

7.2. Special tool to turn the terminal box

Note:

This special tool is not included in the scope of delivery of the valve, see [“Cable plug Type 2509, form A according to DIN EN 175301 - 803” on page 21.](#)

Description	Components of the set
Set SC02-AC10 	<ul style="list-style-type: none"> • Special wrench • Service manual

8. Ordering information

8.1. Bürkert eShop



Bürkert eShop – Easy ordering and quick delivery

You want to find your desired Bürkert product or spare part quickly and order directly? Our online shop is available for you 24/7. Sign up and enjoy all the benefits.

[Order online now](#)

8.2. Bürkert product filter



Bürkert product filter – Get quickly to the right product

You want to select products comfortably based on your technical requirements? Use the Bürkert product filter and find suitable articles for your application quickly and easily.

[Try out our product filter](#)

8.3. Bürkert Product Enquiry Form

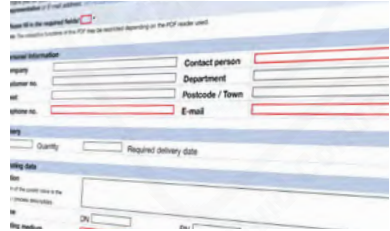

Bürkert Product Enquiry Form – Your enquiry quickly and compactly

Would you like to make a specific product enquiry based on your technical requirements? Use our Product Enquiry Form for this purpose. There you will find all the relevant information for your Bürkert contact. This will enable us to provide you with the best possible advice.

[Fill out the form now](#)

DTS 1000597993 EN Version: - Status: RL (released | freigegeben | valide) printed: 11.12.2023

8.4. Ordering chart

Standard version with brass body

Circuit function A

Note:

Please note that the cable plug Type 2518 is included at the UL Recognized versions. Further information can be found in chapter “Cable plug Type 2518, form A according to DIN EN 175301 - 803” on page 21 or separate data sheet Type 2518 ▶.

Circuit function	Port connection	Orifice [mm]	C _v flow coefficient water ^{1,2)} [gal/min]	Pressure range ³⁾ (MAWP ⁴⁾) [psi]	Weight [lb]	Article no.		
						024/DC	024/50...60	120/50...60
						[V/Hz]	[V/Hz]	[V/Hz]
Seal material NBR, UR (UL-recognized)-approval, coil UL Recognized, medium temperature +14 °F...+176 °F, with cable plug								
CF A 2/2-way solenoid valve Servo-controlled Normally closed 	NPT 1/2	13	4.4	3...232	1.2	314383 ☒	316266 ☒	264073 ☒
	NPT 3/4	20	9.8	3...232	2.0	273429 ☒	316088 ☒	273432 ☒
	NPT 1	25	13.9	3...232	2.9	273433 ☒	273435 ☒	273436 ☒
	NPT 1 1/4	25	13.9	3...232	3.3	273437 ☒	273438 ☒	273440 ☒
	NPT 1 1/2	40	34.7	3...232	6.6	273441 ☒	273443 ☒	273444 ☒
	NPT 2	40	34.7	3...232	7.1	382159 ☒	273446 ☒	273447 ☒
	NPT 2	50	46.2	3...232	9.9	273448 ☒	273449 ☒	273450 ☒
	NPT 2 1/2	50	46.2	3...232	11.5	o. r.	o. r.	369539 ☒
Seal material FKM, UR (UL-recognized)-approval, coil UL Recognized, medium temperature +32 °F...+248 °F, with cable plug								
CF A 2/2-way solenoid valve Servo-controlled Normally closed 	NPT 1/2	13	4.4	3...232	1.2	306761 ☒	306780 ☒	293686 ☒
	NPT 3/4	20	9.8	3...232	2.0	306762 ☒	306781 ☒	293688 ☒
	NPT 1	25	13.9	3...232	2.9	306763 ☒	306782 ☒	293690 ☒
	NPT 1 1/4	25	13.9	3...232	3.3	306764 ☒	306783 ☒	306838 ☒
	NPT 1 1/2	40	34.7	3...232	6.6	306765 ☒	306784 ☒	293689 ☒
	NPT 2	40	34.7	3...232	7.1	o. r.	o. r.	o. r.
	NPT 2	50	46.2	3...232	9.9	306766 ☒	306785 ☒	293691 ☒
	NPT 2 1/2	50	46.2	3...232	11.5	o. r.	338019 ☒	275476 ☒
Seal material EPDM UR (UL-recognized)-approval, coil UL Recognized, medium, temperature -22 °F...+212 °F, with cable plug								
CF A 2/2-way solenoid valve Servo-controlled Normally closed 	NPT 1/2	13	4.4	3...232	1.2	273460 ☒	273462 ☒	273463 ☒
	NPT 3/4	20	9.8	3...232	2.0	273464 ☒	273466 ☒	392858 ☒
	NPT 1	25	13.9	3...232	2.9	273468 ☒	273469 ☒	273470 ☒
	NPT 1 1/4	25	13.9	3...232	3.3	o. r.	o. r.	392857 ☒
	NPT 1 1/2	40	34.7	3...232	6.6	20007617 ☒	o. r.	304992 ☒
	NPT 2	40	34.7	3...232	7.1	o. r.	o. r.	o. r.
	NPT 2	50	46.2	3...232	9.9	336454 ☒	o. r.	392025 ☒
	NPT 2 1/2	50	46.2	3...232	11.5	o. r.	o. r.	o. r.

o. r. = on request

- 1.) Flow coefficient at +60 °F and pressure drop of 1 psi²⁾
- 2.) A pressure difference of 7.5 psi is required to open the full cross-section.
- 3.) Pressure indication: overpressure to atmospheric pressure
- 4.) Maximum allowable working pressure

DTS 1000597993 EN Version: - Status: RL (released | freigegeben | validé) printed: 11.12.2023

Circuit function B

Note:

Please note that the cable plug Type 2518 is included at the UL Recognized versions. Further information can be found in chapter “**Cable plug Type 2518, form A according to DIN EN 175301 - 803**” on page 21 or separate data sheet **Type 2518** ▶.

Circuit function	Port connection	Orifice	C _v flow coefficient water ^{1.)2.)}	Pressure range ^{3.)} (MAWP ^{4.)})	Weight	Article no.		
						024/DC	024/60	120/60
		[mm]	[gal/min]	[psi]	[lb]	[V/Hz]	[V/Hz]	[V/Hz]
Seal material NBR, UR (UL-recognized)-approval, coil UL Recognized, medium temperature + 14 °F...+ 176 °F, with cable plug								
CF B 2/2-way solenoid valve Servo-controlled Normally open 	NPT ½	13	4.4	3...232	1.2	264080 ☒	264083 ☒	264084 ☒
	NPT ¾	20	9.8	3...232	2.0	273471 ☒	273472 ☒	273473 ☒
	NPT 1	25	13.9	3...232	2.9	273474 ☒	273475 ☒	273476 ☒
	NPT 1¼	25	13.9	3...232	3.3	273477 ☒	273478 ☒	273479 ☒
	NPT 1½	40	34.7	3...232	6.6	273480 ☒	273481 ☒	273483 ☒
	NPT 2	40	34.7	3...232	7.1	273485 ☒	273486 ☒	273487 ☒
	NPT 2	50	46.2	3...232	9.9	273488 ☒	273489 ☒	273490 ☒
	NPT 2½	50	46.2	3...232	11.5	o. r.	o. r.	o. r.

o. r. = on request

- 1.) Flow coefficient at + 60 °F and pressure drop of 1 psi^{2.)}
- 2.) A pressure difference of 7.5 psi is required to open the full cross-section.
- 3.) Pressure indication: overpressure to atmospheric pressure
- 4.) Maximum allowable working pressure

Circuit function B

Note:

Please note that the cable plug Type 2518 is included at the UL Recognized versions. Further information can be found in chapter “**Cable plug Type 2518, form A according to DIN EN 175301 - 803**” on page 21 or separate data sheet **Type 2518** ▶.

Circuit function	Port connection	Orifice	C _v flow coefficient water ^{1.)2.)}	Pressure range ^{3.)} (MAWP ^{4.)})	Weight	Article no.		
						024/DC	024/50...60	120/60
		[mm]	[gal/min]	[psi]	[lb]	[V/Hz]	[V/Hz]	[V/Hz]
Seal material FKM, UR (UL-recognized)-approval, coil UL Recognized, medium temperature + 32 °F...+ 248 °F, with cable plug								
CF B 2/2-way solenoid valve Servo-controlled Normally open 	NPT ½	13	4.4	3...232	1.2	306767 ☒	–	306798 ☒
	NPT ¾	20	9.8	3...232	2.0	306768 ☒	–	306799 ☒
	NPT 1	25	13.9	3...232	2.9	306769 ☒	–	306800 ☒
	NPT 1¼	25	13.9	3...232	3.3	306770 ☒	–	306801 ☒
	NPT 1½	40	34.7	3...232	6.6	306772 ☒	–	306802 ☒
	NPT 2	40	34.7	3...232	7.1	o. r.	–	o. r.
	NPT 2	50	46.2	3...232	9.9	306773 ☒	–	306803 ☒
	NPT 2½	50	46.2	3...232	11.5	–	–	–
	NPT ½	13	4.4	3...232	1.4	–	306786 ☒	–
	NPT ¾	20	9.8	3...232	2.1	–	306787 ☒	–
	NPT 1	25	13.9	3...232	3.1	–	306788 ☒	–
	NPT 1¼	25	13.9	3...232	3.5	–	306789 ☒	–
	NPT 1½	40	34.9	3...232	6.8	–	306790 ☒	–
	NPT 2	40	34.9	3...232	7.3	–	o. r.	–
	NPT 2	50	46.2	3...232	10.1	–	306791 ☒	–
	NPT 2½	50	46.2	3...232	11.5	–	o. r.	–

o. r. = on request

– = not available

- 1.) Flow coefficient at + 60 °F and pressure drop of 1 psi^{2.)}
- 2.) A pressure difference of 7.5 psi is required to open the full cross-section.
- 3.) Pressure indication: overpressure to atmospheric pressure
- 4.) Maximum allowable working pressure

DTS 1000597993 EN Version: - Status: RL (released | freigegeben | validé) printed: 11.12.2023

Circuit function A

Note:

Please note that the cable plug Type 2509 is included at the UL Listed versions. Further information can be found in chapter **“Cable plug Type 2509, form A according to DIN EN 175301 - 803” on page 21** or separate data sheet **Type 2509** ▶.

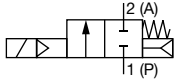
Circuit function	Port connection	Orifice [mm]	C _v flow coefficient water ^{1.)2.)} [gal/min]	Pressure range ^{3.)} (MAWP ^{4.)} [psi]	Weight [lb]	Article no.		
						024/DC	024/50...60	120/50...60
						[V/Hz]	[V/Hz]	[V/Hz]
Seal material FKM, UL (UL Listed) approval, coil UL Recognized, medium temperature + 32 °F...+ 248 °F, with cable plug								
CF A 2/2-way solenoid valve Servo-controlled Normally closed 	NPT ½	13	4.4	3...232	1.2	306547	306585	306617
	NPT ¾	20	9.8	3...232	2.0	306548	306586	306618
	NPT 1	25	13.9	3...232	2.9	306552	306588	306619
	NPT 1¼	25	13.9	3...232	3.3	306560	306589	306620
	NPT 1½	40	34.7	3...232	6.6	306561	306592	306621
	NPT 2	50	46.2	3...232	9.9	306562	306593	306622
	NPT 2½	50	46.2	3...232	11.5	303513	o. r.	303598

o. r. = on request

- 1.) Flow coefficient at + 60 °F and pressure drop of 1 psi^{2.)}
- 2.) A pressure difference of 7.5 psi is required to open the full cross-section.
- 3.) Pressure indication: overpressure to atmospheric pressure
- 4.) Maximum allowable working pressure

Circuit function B

Note:

Please note that the cable plug Type 2509 is included at the UL Listed versions. Further information can be found in chapter **“Cable plug Type 2509, form A according to DIN EN 175301 - 803” on page 21** or separate data sheet **Type 2509** ▶.

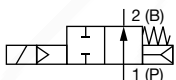
Circuit function	Port connection	Orifice [mm]	C _v flow coefficient water ^{1.)2.)} [gal/min]	Pressure range ^{3.)} (MAWP ^{4.)} [psi]	Weight [lb]	Article no.		
						024/DC	024/50...60	120/60
						[V/Hz]	[V/Hz]	[V/Hz]
Seal material FKM, UL (UL Listed) approval, coil UL Recognized, medium temperature + 32 °F...+ 248 °F, with cable plug								
CF B 2/2-way solenoid valve Servo-controlled Normally open 	NPT ½	13	4.4	3...232	1.2	306570	–	306630
	NPT ¾	20	9.8	3...232	2.0	306572	–	306631
	NPT 1	25	13.9	3...232	2.9	306573	–	306632
	NPT 1¼	25	13.9	3...232	3.3	306574	–	306633
	NPT 1½	40	34.7	3...232	6.6	306575	–	306634
	NPT 2	50	46.2	3...232	9.9	306577	–	306635
	NPT ½	13	4.4	3...232	1.4	–	306603	–
	NPT ¾	20	9.8	3...232	2.1	–	306604	–
	NPT 1	25	13.9	3...232	3.1	–	306605	–
	NPT 1¼	25	13.9	3...232	3.5	–	306607	–
	NPT 1½	40	34.7	3...232	6.8	–	306608	–
	NPT 2	50	46.2	3...232	10.1	–	306609	–

– = not available

- 1.) Flow coefficient at + 60 °F and pressure drop of 1 psi^{2.)}
- 2.) A pressure difference of 7.5 psi is required to open the full cross-section.
- 3.) Pressure indication: overpressure to atmospheric pressure
- 4.) Maximum allowable working pressure

DTS 1000597993 EN Version: - Status: RL (released | freigegeben | validé) printed: 11.12.2023

Circuit function A, with Kick and Drop coil

Note:

Please note that the cable plug Type 2518 is included. Further information can be found in chapter “Cable plug Type 2518, form A according to DIN EN 175301 - 803” on page 21 or separate data sheet **Type 2518** ▶.

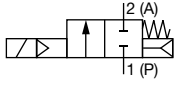
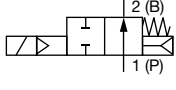
Circuit function	Port connection	Orifice [mm]	C _v flow coefficient water ^{1.)2.)} [gal/min]	Pressure range ^{3.)} (MAWP ^{4.)} [psi]	Weight [lb]	Article no.	
						024/UC	120/50...60
						[V/Hz]	[V/Hz]
Seal material FKM, coil UL Recognized, medium temperature +32 °F...+248 °F, with cable plug							
CF A 2/2-way solenoid valve Servo-controlled Normally closed 	NPT ¼	10	1.7	3...232	1.2	20046915	20046943
	NPT ⅜	10	2.2	3...232	1.1	20046916	20046944
	NPT ½	13	4.4	3...232	1.4	20046917	20046945
	NPT ¾	20	9.8	3...232	2.1	20046918	20046946
	NPT 1	25	13.9	3...232	3.1	20046919	20046947
	NPT 1¼	25	13.9	3...232	3.5	20046920	20046948
	NPT 1½	40	34.7	3...232	6.8	20046921	20046949
	NPT 2	40	34.7	3...232	7.3	o. r.	o. r.
	NPT 2	50	46.2	3...232	10.1	20046922	20046950
	NPT 2½	50	46.2	3...232	11.5	20046923	20046951
CF B 2/2-way solenoid valve Servo-controlled Normally open 	NPT ¼	10	1.7	3...232	1.2	20046934	20046952
	NPT ⅜	10	2.2	3...232	1.1	20046935	20046953
	NPT ½	13	4.4	3...232	1.4	20046936	20046954
	NPT ¾	20	9.8	3...232	2.1	20046937	20046955
	NPT 1	25	13.9	3...232	3.1	20046938	20046956
	NPT 1¼	25	13.9	3...232	3.5	20046939	20046957
	NPT 1½	40	34.7	3...232	6.8	20046940	20046958
	NPT 2	40	34.7	3...232	7.3	o. r.	o. r.
	NPT 2	50	46.2	3...232	10.1	20046941	20046959
	NPT 2½	50	46.2	3...232	11.5	20046942	20046960

o. r. = on request

- 1.) Flow coefficient at +60 °F and pressure drop of 1 psi^{2.)}
- 2.) A pressure difference of 7.5 psi is required to open the full cross-section.
- 3.) Pressure indication: overpressure to atmospheric pressure
- 4.) Maximum allowable working pressure

Standard version with stainless steel body

Circuit function A

Note:

Please note that the cable plug Type 2518 is included at the UL Recognized versions. Further information can be found in chapter “Cable plug Type 2518, form A according to DIN EN 175301 - 803” on page 21 or separate data sheet **Type 2518** ▶.

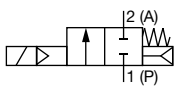
Circuit function	Port connection	Orifice [mm]	C _v flow coefficient water ^{1.)2.)} [gal/min]	Pressure range ^{3.)} (MAWP ^{4.)} [psi]	Weight [lb]	Article no.		
						024/DC	024/50...60	120/50...60
						[V/Hz]	[V/Hz]	[V/Hz]
Seal material FKM, UR (UL-recognized)-approval, coil UL Recognized, medium temperature +32 °F...+248 °F, with cable plug								
CF A 2/2-way solenoid valve Servo-controlled Normally closed 	NPT ½	13	4.4	3...232	1.2	307890	307907	307915
	NPT ¾	20	9.8	3...232	1.9	307901	307908	307916
	NPT 1	25	13.9	3...232	2.9	307903	307909	307917
	NPT 1¼	25	13.9	3...232	3.1	307904	307910	307918
	NPT 1½	40	34.7	3...232	6.2	307906	307912	307919
	NPT 2	40	34.7	3...232	6.6	307905	307913	307920

- 1.) Flow coefficient at +60 °F and pressure drop of 1 psi^{2.)}
- 2.) A pressure difference of 7.5 psi is required to open the full cross-section.
- 3.) Pressure indication: overpressure to atmospheric pressure
- 4.) Maximum allowable working pressure

DTS 1000597993 EN Version: - Status: RL (released | freigegeben | validé) printed: 11.12.2023



Circuit function B

Note:

Please note that the cable plug Type 2518 is included at the UL Recognized versions. Further information can be found in chapter “**Cable plug Type 2518, form A according to DIN EN 175301 - 803**” on page 21 or separate data sheet **Type 2518** ▶.

Circuit function	Port connection	Orifice [mm]	C _v flow coefficient water ^{1.)2.)} [gal/min]	Pressure range ^{3.)} (MAWP ^{4.)} [psi]	Weight [lb]	Article no.		
						024/DC	024/50...60	120/60
						[V/Hz]	[V/Hz]	[V/Hz]
Seal material FKM, UR (UL-recognized)-approval, coil UL Recognized, medium temperature +32 °F...+248 °F, with cable plug								
CF B 2/2-way solenoid valve Servo-controlled Normally open 	NPT ½	13	4.4	3...232	1.2	306774	–	306804
	NPT ¾	20	9.8	3...232	1.9	306775	–	306805
	NPT 1	25	13.9	3...232	2.9	306776	–	306806
	NPT 1¼	25	13.9	3...232	3.1	306777	–	306807
	NPT 1½	40	34.7	3...232	6.2	306778	–	306808
	NPT 2	40	34.7	3...232	6.6	306779	–	306809
	NPT ½	13	4.4	3...232	1.4	–	306792	–
	NPT ¾	20	9.8	3...232	2.1	–	306793	–
	NPT 1	25	13.9	3...232	3.1	–	306794	–
	NPT 1¼	25	13.9	3...232	3.3	–	306795	–
	NPT 1½	40	34.7	3...232	6.4	–	306796	–
	NPT 2	40	34.7	3...232	6.8	–	306797	–

– = not available

- 1.) Flow coefficient at +60 °F and pressure drop of 1 psi^{2.)}
- 2.) A pressure difference of 7.5 psi is required to open the full cross-section.
- 3.) Pressure indication: overpressure to atmospheric pressure
- 4.) Maximum allowable working pressure

Circuit function A

Note:

Please note that the cable plug Type 2509 is included at the UL Listed versions. Further information can be found in chapter “**Cable plug Type 2509, form A according to DIN EN 175301 - 803**” on page 21 or separate data sheet **Type 2509** ▶.

Circuit function	Port connection	Orifice [mm]	C _v flow coefficient water ^{1.)2.)} [gal/min]	Pressure range ^{3.)} (MAWP ^{4.)} [psi]	Weight [lb]	Article no.		
						024/DC	024/50...60	120/50...60
						[V/Hz]	[V/Hz]	[V/Hz]
Seal material FKM, UL (UL Listed) approval, coil UL Recognized, medium temperature +32 °F...+248 °F, with cable plug								
CF A 2/2-way solenoid valve Servo-controlled Normally closed 	NPT ½	13	4.4	3...232	1.2	306563	306595	306623
	NPT ¾	20	9.8	3...232	2.0	306564	306596	306624
	NPT 1	25	13.9	3...232	2.9	306566	306597	306625
	NPT 1¼	25	13.9	3...232	3.3	306567	306599	306626
	NPT 1½	40	34.7	3...232	6.2	306568	306600	306627
	NPT 2	40	34.7	3...232	6.6	306569	306602	306629

- 1.) Flow coefficient at +60 °F and pressure drop of 1 psi^{2.)}
- 2.) A pressure difference of 7.5 psi is required to open the full cross-section.
- 3.) Pressure indication: overpressure to atmospheric pressure
- 4.) Maximum allowable working pressure

DTS 1000597993 EN Version: - Status: RL (released | freigegeben | validé) printed: 11.12.2023

Circuit function B

Note:

Please note that the cable plug Type 2509 is included at the UL Listed versions. Further information can be found in chapter “Cable plug Type 2509, form A according to DIN EN 175301 - 803” on page 21 or separate data sheet **Type 2509** ▶.

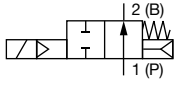
Circuit function	Port connection	Orifice [mm]	C _v flow coefficient water ^{1.)2.)} [gal/min]	Pressure range ^{3.)} (MAWP ^{4.)} [psi]	Weight [lb]	Article no.		
						024/DC	024/50...60	120/60
						[V/Hz]	[V/Hz]	[V/Hz]
Seal material FKM, UL(UL Listed) approval, coil UL Recognized, medium temperature +32 °F...+248 °F, with cable plug								
CF B 2/2-way solenoid valve Servo-controlled Normally open 	NPT ½	13	4.4	3...232	1.2	306578	–	306637
	NPT ¾	20	9.8	3...232	1.9	306579	–	306638
	NPT 1	25	13.9	3...232	2.9	306580	–	306639
	NPT 1¼	25	13.9	3...232	3.1	306581	–	306640
	NPT 1½	40	34.7	3...232	6.2	306583	–	306641
	NPT 2	40	134.7	3...232	6.6	306584	–	306643
	NPT ½	13	4.4	3...232	1.4	–	306610	–
	NPT ¾	20	9.8	3...232	2.1	–	306611	–
	NPT 1	25	13.9	3...232	3.1	–	306612	–
	NPT 1¼	25	13.9	3...232	3.3	–	306614	–
	NPT 1½	40	34.7	3...232	6.4	–	306615	–
	NPT 2	40	34.7	3...232	6.8	–	306616	–

– = not available

- 1.) Flow coefficient at +60 °F and pressure drop of 1 psi^{2.)}
- 2.) A pressure difference of 7.5 psi is required to open the full cross-section.
- 3.) Pressure indication: overpressure to atmospheric pressure
- 4.) Maximum allowable working pressure

Coil UL Listed (cULus) for hazardous locations, Class I, Division 2, electrical connection with 3 m cable

Note:

- The maximum medium temperature must never exceed the permitted temperature class (T4: +275 °F, T5: +212 °F, T6: +212 °F) minus 9 °F.
- Refer to chapter “3. Approvals and conformities” on page 4 for more information about the approvals.

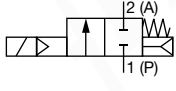
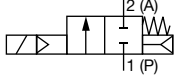
Circuit function	Port connection	Orifice [mm]	C _v flow coefficient water ^{1.)2.)} [gal/min]	Pressure range ^{3.)} (MAWP ^{4.)} [psi]	Weight [lb]	Article no.	
						024/ AC/DC	120/60
						[V/Hz]	[V/Hz]
Seal material FKM, brass body, medium temperature +32 °F...+248 °F							
CF A 2/2-way solenoid valve Servo-controlled Normally closed 	NPT ¼	10	1.7	3...232	1..4	20013600	20013601
	NPT ½	13	4.4	3...232	1.8	378848	371835
	NPT ¾	20	9.8	3...232	2.7	378849	378854
	NPT 1	25	13.9	3...232	3.5	378850	372932
	NPT 1¼	25	13.9	3...232	4.0	378851	378855
	NPT 1½	40	34.7	3...232	7.3	378852	378856
	NPT 2	50	46.2	3...232	10.6	378853	378857
Seal material FKM, stainless steel body, medium temperature +32 °F...+248 °F							
CF A 2/2-way solenoid valve Servo-controlled Normally closed 	NPT ½	13	4.4	3...232	1.8	378858	378864
	NPT ¾	20	9.8	3...232	2.7	378859	378865
	NPT 1	25	13.9	3...232	3.5	378860	378866
	NPT 1¼	25	13.9	3...232	3.8	378861	378867
	NPT 1½	40	34.7	3...232	6.8	378862	378868
	NPT 2	40	34.7	3...232	7.3	382488	382489

- 1.) Flow coefficient at +60 °F and pressure drop of 1 psi^{2.)}
- 2.) A pressure difference of 7.5 psi is required to open the full cross-section.
- 3.) Pressure indication: overpressure to atmospheric pressure
- 4.) Maximum allowable working pressure

DTS 1000597993 EN Version: - Status: RL (released | freigegeben | validé) printed: 11.12.2023

Further versions on request			
	Material Brass dezincification resistant		Voltage Further voltages
	Process connection NPT, G		Approval UL approval UL429 (Var. Code PE94/PE95)

8.5. Ordering chart accessories

Cable plug Type 2518, form A according to DIN EN 175301 - 803

Note:

For further versions see data sheet **Type 2518** ▶.

Cable plug	Dimensions	Version	Voltage	Article no.
		Without circuitry (AC/DC)	0...250 V AC/DC	314802
		With LED (AC/DC)	12...24 V AC/DC	314812
		With LED and varistor (AC/DC)	12...24 V AC/DC	314820
		With rectifier, LED and varistor	12...24 V AC/DC	314816
		Without circuitry (AC/DC) with silicone seal for higher ambient temperature, e.g. steam version (NA07)	0...250 V AC/DC	361687

Cable plug Type 2509, form A according to DIN EN 175301 - 803

Note:

- Without circuitry (standard)
- Refer to data sheet **Type 2509** ▶ for more information about the cable plug.

Cable plug	Dimensions	Version	Voltage	Article no.
		Without circuitry	0...250 V AC/DC	137943

DTS 1000597993 EN Version: - Status: RL (released | freigegeben | valide) printed: 11.12.2023

Cable glands for ATEX/IECEX terminal box

Note:

- A cable gland in polyamide version is included in the delivery. A nickel-plated brass version can be ordered at surcharge.
- Refer to “7.1. Cable glands for ATEX/IECEX terminal box” on page 12 for more information about Ex cable glands.
- Refer to “7.2. Special tool to turn the terminal box” on page 13 for more information about Special wrench.

Description	Article no.
Ex cable gland, nickel-plated brass, 6...13 mm ^{1.)}	773278 𠄎
Ex cable gland, polyamide, 7...13 mm ^{1.)}	773277 𠄎
Set SC02-AC10: Special wrench ^{2.)} incl. service manual	293488 𠄎

1.) Cable diameter

2.) Not included in the scope of delivery of the valve

Mounting set for DN 10

Cable plug	Dimensions	Description	Article no.
		Mounting bracket kit (consisting of mounting bracket and screws)	365730 𠄎

DTS 1000597993 EN Version: - Status: RL (released | freigegeben | validé) printed: 11.12.2023