



### Plunger valve 2/2-way direct-acting

- Direct-acting and compact valve up to diameter of DN 6.0
- Vibration-proof, bolted coil system
- Explosion proof versions
- Energy-saving version with Kick and Drop available

Product variants described in the data sheet may differ from the product presentation and description.

#### Can be combined with



**Type 1087**  
Timer,  
form A according to  
DIN EN 175301 - 803



**Type 2518**  
Cable plug,  
form A according to  
DIN EN 175301 - 803



**Type 2509**  
Cable plug,  
form A according to  
DIN EN 175301 - 803

#### Type description

Valve 6013 is a direct-acting plunger valve. The stopper and plunger guide tube are welded together to enhance pressure resistance and leak-tightness. Various seal material combinations are available depending on the application. A Bürkert-specific flange design (SFB) enables space-saving arrangement of valves on a manifold. Kick and Drop coils are available for the reduction of electrical power consumption during operation.



**Table of contents**

<b>1. General technical data</b>	<b>4</b>
1.1. Standard version.....	4
1.2. Analytical version.....	5
1.3. DVGW version.....	5
<b>2. Circuit functions</b>	<b>5</b>
<b>3. Approvals and conformities</b>	<b>6</b>
3.1. General notes.....	6
3.2. Conformity.....	6
3.3. Standards.....	6
3.4. Explosion protection.....	6
3.5. North America (USA/Canada).....	7
3.6. Drinking water.....	7
3.7. Foods and beverages/Hygiene.....	7
3.8. Others.....	8
Fuel gases.....	8
<b>4. Materials</b>	<b>8</b>
4.1. Bürkert resistApp.....	8
4.2. Material specifications.....	8
Standard version.....	8
ATEX/IECEX cable version.....	9
ATEX/IECEX terminal box version.....	10
<b>5. Dimensions</b>	<b>11</b>
5.1. Standard version.....	11
5.2. ATEX/IECEX cable version.....	12
5.3. ATEX/IECEX terminal box version.....	13
5.4. Single manifold.....	14
5.5. Multiple manifold.....	15
5.6. Manifolds for block mounting.....	15
<b>6. Performance specifications</b>	<b>16</b>
6.1. Power consumption.....	16
Circuit function A.....	16
Circuit function B.....	16
<b>7. Product installation</b>	<b>17</b>
7.1. Installation notes.....	17
Control for impulse version with polarity reversal control.....	17
<b>8. Product accessories</b>	<b>18</b>
8.1. Cable glands for ATEX/IECEX terminal box.....	18
8.2. Special tool to turn the terminal box.....	18
<b>9. Ordering information</b>	<b>19</b>
9.1. Bürkert eShop.....	19
9.2. Bürkert product filter.....	19
9.3. Bürkert Product Enquiry Form.....	19

DTS 1000011032 EN Version: AK Status: RL (released | freigegeben | validé) printed: 20.03.2024

- 9.4. Ordering chart .....20
  - Standard version .....20
  - Impulse version .....21
  - Analytical version .....22
  - DVGW version .....22
  - ATEX/IECEX cable version .....23
  - ATEX/IECEX terminal box version .....23
- 9.5. Ordering chart accessories .....24
  - Singel manifold .....24
  - Multiple manifold .....24
  - Cable plug Type 2518, form A according to DIN EN 175301 - 803 .....24
  - Cable plug Type 2509, form A according to DIN EN 175301 - 803 .....25
  - Cable glands for ATEX/IECEX terminal box .....25

DTS 1000011032 EN Version: AK Status: RL (released | freigegeben | valide) printed: 20.03.2024

## 1. General technical data

### 1.1. Standard version

Product properties	
Dimensions	Further information can be found in chapter <b>"5. Dimensions"</b> on page 11.
Material	
Seal	FKM, PTFE/Graphite (EPDM on request)
Body	Brass, stainless steel 1.4305/303
Coil	Polyamide or epoxy
Orifice	DN 2.0...DN 6.0
Circuit function	A and B Further information can be found in chapter <b>"2. Circuit functions"</b> on page 5.
Thermal insulation class of solenoid coil	Polyamide coil class B Epoxy coil class H
Performance data	
Duty cycle/single valve with block assembly on manifold	100 % continuous operation Intermittent operation 60 % (30 min) or with 5 W coil (on request)
Electrical data	
Operating voltage	
Standard version	24 V/DC, 24 V/50 Hz, 24 V/60 Hz, 120 V/50 Hz, 230 V/50 Hz, 240 V /60 Hz
Analytical version	24 V/DC, 230 V/50 Hz (other voltages on request)
Power consumption	Further information can be found in chapter <b>"6. Performance specifications"</b> on page 16.
Voltage tolerance	± 10 %
Medium data	
Operating medium	
Standard version	Technical vacuum, neutral gases and fluids (e.g. compressed air, water, hydraulic oil)
Analytical version	Neutral medium which do not attack the body and seal materials Further information can be found in chapter <b>"4.1. Bürkert resistApp"</b> on page 8.
Medium temperature	
With FKM	- 10 °C...+ 100 °C (PA coil), - 10 °C...+ 120 °C (Epoxy coil), - 40 °C on request
With PTFE/Graphite	- 40 °C...+ 180 °C (further information can be found in chapter <b>"4.1. Bürkert resistApp"</b> on page 8)
With FKM, circuit function B	- 10 °C...100 °C (AC), - 10 °C...120 °C (DC)
Viscosity	Max. 21 mm <sup>2</sup> /s
Process/Port connection & communication	
Electrical connection	<ul style="list-style-type: none"> <li>Plug contacts according to DIN EN 175 301 -803 form A for cable plug <b>Type 2518</b> ▶ Further information can be found in chapter <b>"Cable plug Type 2518, form A according to DIN EN 175301 -803"</b> on page 24.</li> <li>Plug contacts according to DIN EN 175 301 -803 form A for cable plug <b>Type 2509</b> ▶ Further information can be found in chapter <b>"Cable plug Type 2509, form A according to DIN EN 175301 -803"</b> on page 25.</li> <li>ATEX/IECEx version with 3 m moulded cable or terminal cable</li> </ul>
Port connection	
Standard version	G 1/8, G 1/4, G 3/8, NPT 1/8, NPT 1/4, NPT 3/8, manifold (SFB)
Analytical version	G 1/8, G 1/4, NPT 1/8, NPT 1/4
Approvals and conformities	
Degree of protection	IP65 with cable plug
Explosion protection	Further information can be found in chapter <b>"3.4. Explosion protection"</b> on page 6.
North America (USA/Canada)	Further information can be found in chapter <b>"3.5. North America (USA/Canada)"</b> on page 7.
Environment and installation	
Installation position	As required, preferably with actuator upright
Ambient temperature	Max. +55 °C (higher temperatures on request)

### 1.2. Analytical version

This version is particularly suitable for switching from extremely pure gaseous medium. All medium-affected parts are submitted to additional purification processes, so that the medium is not contaminated under any circumstances.

The tightness test takes place at the Helium leak detector from a min. of  $10^{-4}$  mbar l/sec.

Product properties	
<b>Material</b>	
Seal	Silicon, oil and fat free version Tightness $< 10^{-4}$ mbar l/s
Body	Brass, stainless steel 1.4305/303
<b>Medium data</b>	
Operating medium	Neutral medium, which does not attack the body and seal materials Further information can be found in chapter "4.1. Bürkert resistApp" on page 8.
<b>Environment and installation</b>	
Installation instructions	No oils, fats or silicone to be used during installation.

### 1.3. DVGW version

The solenoid valve Type 6013 DVGW is primarily intended as an automatic safety shut-off valve for fuel gases. A strainer is installed in the inlet of the valve.

Product properties	
<b>Material</b>	
Seal	NBR
Body	Brass, stainless steel 1.4305/303
Circuit function	A Further information can be found in chapter "2. Circuit functions" on page 5.
<b>Performance data</b>	
Operating pressure	Max. 0...5 bar
<b>Medium data</b>	
Operating medium	Fuel gases (e.g. town gas, district gas, liquid gas) Further information can be found in chapter "4.1. Bürkert resistApp" on page 8.
Medium temperature	0 °C...+80 °C
<b>Approvals and conformities</b>	
Standards	DIN EN 161:2013, DIN EN 13611:2016
<b>Environment and installation</b>	
Ambient temperature	-20 °C...+55 °C

## 2. Circuit functions

Symbol	Description
	<b>Circuit function A (CF A)</b> 2/2-way solenoid valve Direct-acting Normally closed
	<b>Circuit function B (CF B)</b> 2/2-way solenoid valve Direct-acting Normally open

DTS 1000011032 EN Version: AK Status: RL (released | freigegeben | validé) printed: 20.03.2024

### 3. Approvals and conformities

#### 3.1. General notes

- The approvals and conformities listed below must be stated when making enquiries. This is the only way to ensure that the product complies with all required specifications.
- Not all available versions can be supplied with the below mentioned approvals or conformities.



#### 3.2. Conformity

In accordance with the Declaration of Conformity, the product is compliant with the EU Directives.

#### 3.3. Standards

The applied standards which are used to demonstrate compliance with the EU Directives are listed in the EU-Type Examination Certificate and/or the EU Declaration of Conformity.

#### 3.4. Explosion protection

Approval	Description																
  	<p><b>Optional: Explosion protection according to category 2 (zone 1/21)</b></p> <p>Ex marking of the components according to the following table:</p> <table border="1" style="width: 100%; border-collapse: collapse;"> <thead> <tr style="background-color: #d9e1f2;"> <th colspan="2">Coil Type AC10</th> </tr> <tr style="background-color: #d9e1f2;"> <th>Coils with cable outlet</th> <th>Coils with terminal box</th> </tr> </thead> <tbody> <tr> <td> <b>ATEX:</b>                      EPS 18 ATEX 1232 X                      II 2G Ex mb IIC T4 Gb                      II 2D Ex mb IIIC T130 °C Db                 </td> <td> <b>ATEX:</b>                      EPS 18 ATEX 1232 X                      II 2G Ex eb mb IIC T4 Gb                      II 2D Ex mb tb IIIC T130 °C Db                 </td> </tr> <tr> <td> <b>IECEX:</b>                      IECEX EPS 18.0110 X                      Ex mb IIC T4 Gb                      Ex mb IIIC T130 °C Db                 </td> <td> <b>IECEX:</b>                      IECEX EPS 18.0110 X                      Ex eb mb IIC T4 Gb                      Ex mb tb IIIC T130 °C Db                 </td> </tr> </tbody> </table> <p><b>Optional: Explosion protection according to category 3 (zone 2/22)</b></p> <p>Ex marking of the components according to the following table:</p> <table border="1" style="width: 100%; border-collapse: collapse;"> <thead> <tr style="background-color: #d9e1f2;"> <th colspan="2">Coil Type AC10</th> </tr> <tr style="background-color: #d9e1f2;"> <th colspan="2">Coil with plug contacts form A and cable plug Type 2509</th> </tr> </thead> <tbody> <tr> <td colspan="2"> <b>ATEX:</b>                      EPS 18 ATEX 1232 X                      II 2G Ex mb IIC T4 Gb                      II 2D Ex mb IIIC T130 °C Db                 </td> </tr> <tr> <td colspan="2"> <b>IECEX:</b>                      IECEX EPS 18.0110 X                      Ex mb IIC T4 Gb                      Ex mb IIIC T130 °C Db                 </td> </tr> </tbody> </table>	Coil Type AC10		Coils with cable outlet	Coils with terminal box	<b>ATEX:</b> EPS 18 ATEX 1232 X II 2G Ex mb IIC T4 Gb II 2D Ex mb IIIC T130 °C Db	<b>ATEX:</b> EPS 18 ATEX 1232 X II 2G Ex eb mb IIC T4 Gb II 2D Ex mb tb IIIC T130 °C Db	<b>IECEX:</b> IECEX EPS 18.0110 X Ex mb IIC T4 Gb Ex mb IIIC T130 °C Db	<b>IECEX:</b> IECEX EPS 18.0110 X Ex eb mb IIC T4 Gb Ex mb tb IIIC T130 °C Db	Coil Type AC10		Coil with plug contacts form A and cable plug Type 2509		<b>ATEX:</b> EPS 18 ATEX 1232 X II 2G Ex mb IIC T4 Gb II 2D Ex mb IIIC T130 °C Db		<b>IECEX:</b> IECEX EPS 18.0110 X Ex mb IIC T4 Gb Ex mb IIIC T130 °C Db	
Coil Type AC10																	
Coils with cable outlet	Coils with terminal box																
<b>ATEX:</b> EPS 18 ATEX 1232 X II 2G Ex mb IIC T4 Gb II 2D Ex mb IIIC T130 °C Db	<b>ATEX:</b> EPS 18 ATEX 1232 X II 2G Ex eb mb IIC T4 Gb II 2D Ex mb tb IIIC T130 °C Db																
<b>IECEX:</b> IECEX EPS 18.0110 X Ex mb IIC T4 Gb Ex mb IIIC T130 °C Db	<b>IECEX:</b> IECEX EPS 18.0110 X Ex eb mb IIC T4 Gb Ex mb tb IIIC T130 °C Db																
Coil Type AC10																	
Coil with plug contacts form A and cable plug Type 2509																	
<b>ATEX:</b> EPS 18 ATEX 1232 X II 2G Ex mb IIC T4 Gb II 2D Ex mb IIIC T130 °C Db																	
<b>IECEX:</b> IECEX EPS 18.0110 X Ex mb IIC T4 Gb Ex mb IIIC T130 °C Db																	

DTS 1000011032 EN Version: AK Status: RL (released | freigegeben | validé) printed: 20.03.2024

3.5. North America (USA/Canada)

Approval	Description
	<b>Optional: UL Listed for the USA (valid for valves)</b> The valves are UL Listed for the USA according to: <ul style="list-style-type: none"> <li>UL 429 (electrically operated valves)</li> </ul>
	<b>Optional: UL Hazardous Locations – Explosion Protection (valid for coils)</b> UL Listed for Hazardous Locations for USA and Canada Class I, Zone 1 Class I, Division 2, Group A, B, C and D Class II + III, Division 2, Group F and G
	<b>Optional: UL Recognized for the USA (valid for valves)</b> The valves are UL Recognized for the USA according to: <ul style="list-style-type: none"> <li>UL 429 (electrically operated valves)</li> </ul>
	<b>Optional: CSA for Canada (valid for valves)</b> The valves are CSA approved for Canada according to: <ul style="list-style-type: none"> <li>CSA 139 (electrically operated valves)</li> </ul>
	<b>Optional: FM (Factory Mutual) – Explosion Protection (valid for coils)</b> FM for Hazardous Locations for USA and Canada Class I, Zone 1 Class I, Division 1, Groups A, B, C and D Class II + III, Division 1, Groups E, F and G

3.6. Drinking water

Conformity	Description
	<b>Suitable for use in drinking water applications</b> The materials comply with the assessment principles (UBA) for materials in contact with drinking water (TrinkwasserV).  <b>PA body:</b> PF36: Suitable for products with a maximum temperature of 60 °C (warm water)  <b>PPS/brass/stainless steel body:</b> PF39: Suitable for products with a maximum temperature of 85 °C (hot water)

3.7. Foods and beverages/Hygiene

Conformity	Description
	<b>FDA – Code of Federal Regulations (valid for the variable code PL02, PL03)</b> All wetted materials are compliant with the Code of Federal Regulations published by the FDA (Food and Drug Administration, USA) according to the manufacturer’s declaration.
	<b>United States Pharmacopeial Convention (USP) (valid for the variable code PL04)</b> All wetted materials are biocompatible according to the manufacturer’s declaration.
	<b>EC Regulation 1935/2004 of the European Parliament and of the Council (valid for the variable code PL01, PL02)</b> All wetted materials are compliant with EC Regulation 1935/2004/EC according to the manufacturer’s declaration.

DTS 1000011032 EN Version: AK Status: RL (released | freigegeben | validé) printed: 20.03.2024

### 3.8. Others

#### Fuel gases

Conformity	Description
	<b>Fuel gases (valid for the variable code PO16)</b> The products comply with: <ul style="list-style-type: none"> <li>• Regulation (EU) 2016/426 – Appliances burning gaseous fuels and</li> <li>• DVGW DIN EN 161 (Automatic shut-off valves for gas burners and gas appliances) and</li> </ul>
	<b>Optional: DIN EN 549:2023-07 certification</b> The wetted valve seals are compliant with DIN EN 549:2023-07 (Rubber materials for seals and diaphragms for gas appliances and gas equipment) for medium temperatures of 0 °C...+80 °C.

## 4. Materials

### 4.1. Bürkert resistApp



#### Bürkert resistApp – Chemical resistance chart

You want to ensure the reliability and durability of the materials in your individual application case? Verify your combination of media and materials on our website or in our resistApp.

[Start chemical resistance check](#)

### 4.2. Material specifications

#### Standard version

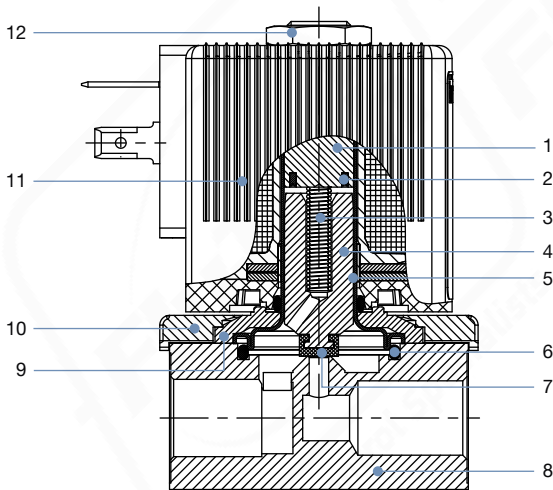

No.	Element	Material
1	Stopper	Stainless steel 1.4105/430F
2	Shading ring	Cu (brass version) Ag (stainless steel version)
3	Spring	Stainless steel 1.4310/301
4	Magnetic core	Stainless steel 1.4105/430F
5	Armature guide tube	Stainless steel 1.4303/305/308
6	Seal	FKM Graphite (high temperature version)
7	Armature seal	FKM PTFE
8	Valve body	Brass Stainless steel 1.4305/303
9	Sub-base	Steel, surface finish thick-film passivated (brass version) Stainless steel 1.4301/304 (stainless steel version)
10	Cover	Polyamide
11	Coil	PA (polyamide) Epoxy
12	Locknut	Steel, surface finish thick-film passivated (brass version) Stainless steel 1.4305/303 PTFE coated (stainless steel version)



ATEX/IECEX cable version

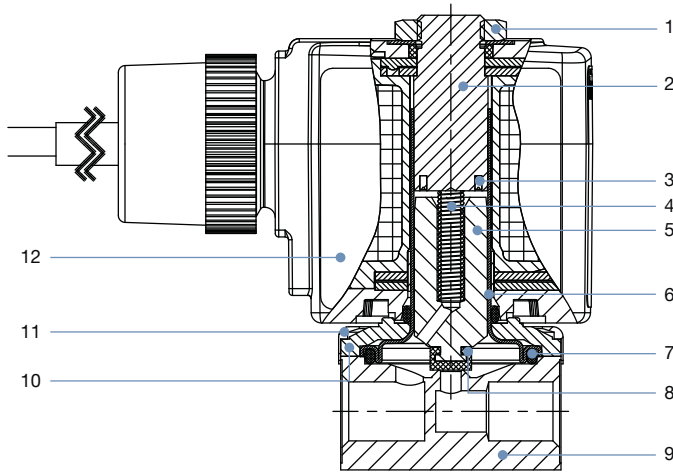

No.	Element	Material
1	Locknut	Steel, surface finish thick-film passivated (brass version) Stainless steel 1.4305/303 PTFE coated (stainless steel version)
2	Stopper	Stainless steel 1.4105/430F
3	Shading ring	Cu (brass version) Ag (stainless steel version)
4	Spring	Stainless steel 1.4310/301
5	Magnetic core	Stainless steel 1.4105/430F
6	Armature guide tube	Stainless steel 1.4303/305/308
7	Seal	FKM Graphite (high temperature version)
8	Armature seal	FKM PTFE (high temperature version)
9	Valve body	Brass Stainless steel 1.4305/303
10	Sub-base	Steel, surface finish thick-film passivated (brass version) Stainless steel 1.4301/304 (stainless steel version)
11	Cover	Polyamide
12	Coil	Epoxy

DTS 1000011032 EN Version: AK Status: RL (released | freigegeben | validé) printed: 20.03.2024



ATEX/IECEX terminal box version

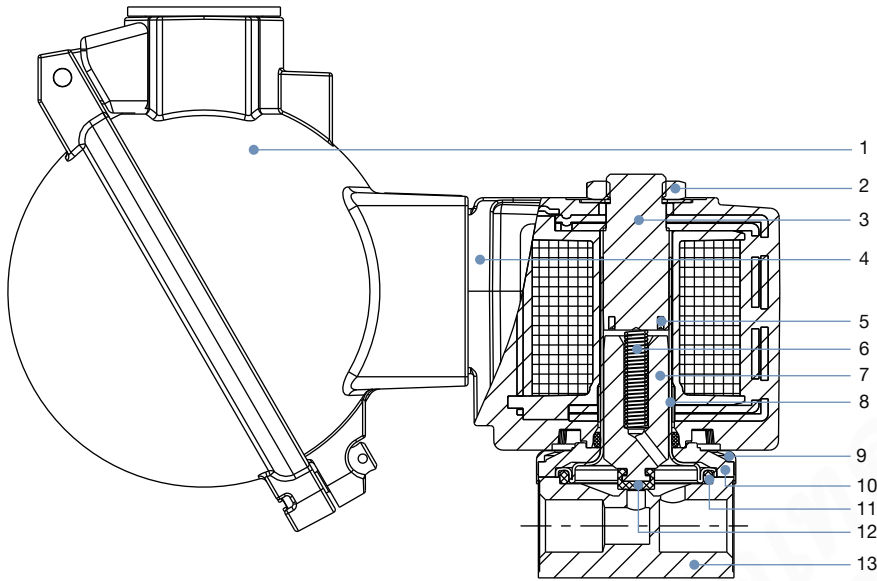

No.	Element	Material
1	Terminal box	Aluminium
2	Locknut	Steel, surface finish thick-film passivated (brass version) Stainless steel 1.4305/303 PTFE coated (stainless steel version)
3	Stopper	Stainless steel 1.4105/430F
4	Coil	Epoxy
5	Shading ring	Cu (brass version) Ag (stainless steel version)
6	Spring	Stainless steel 1.4310/301
7	Magnetic core	Stainless steel 1.4105/430F
8	Armature guide tube	Stainless steel 1.4303/305/308
9	Cover	Polyamide
10	Sub-base	Steel, surface finish thick-film passivated (brass version) Stainless steel 1.4301/304 (stainless steel version)
11	Seal	FKM Graphite (high temperature version)
12	Armature seal	FKM PTFE (high temperature version)
13	Valve body	Brass Stainless steel 1.4305/303

DTS 1000011032 EN Version: AK Status: RL (released | freigegeben | validé) printed: 20.03.2024

## 5. Dimensions

### 5.1. Standard version

**Note:**

Dimensions in mm

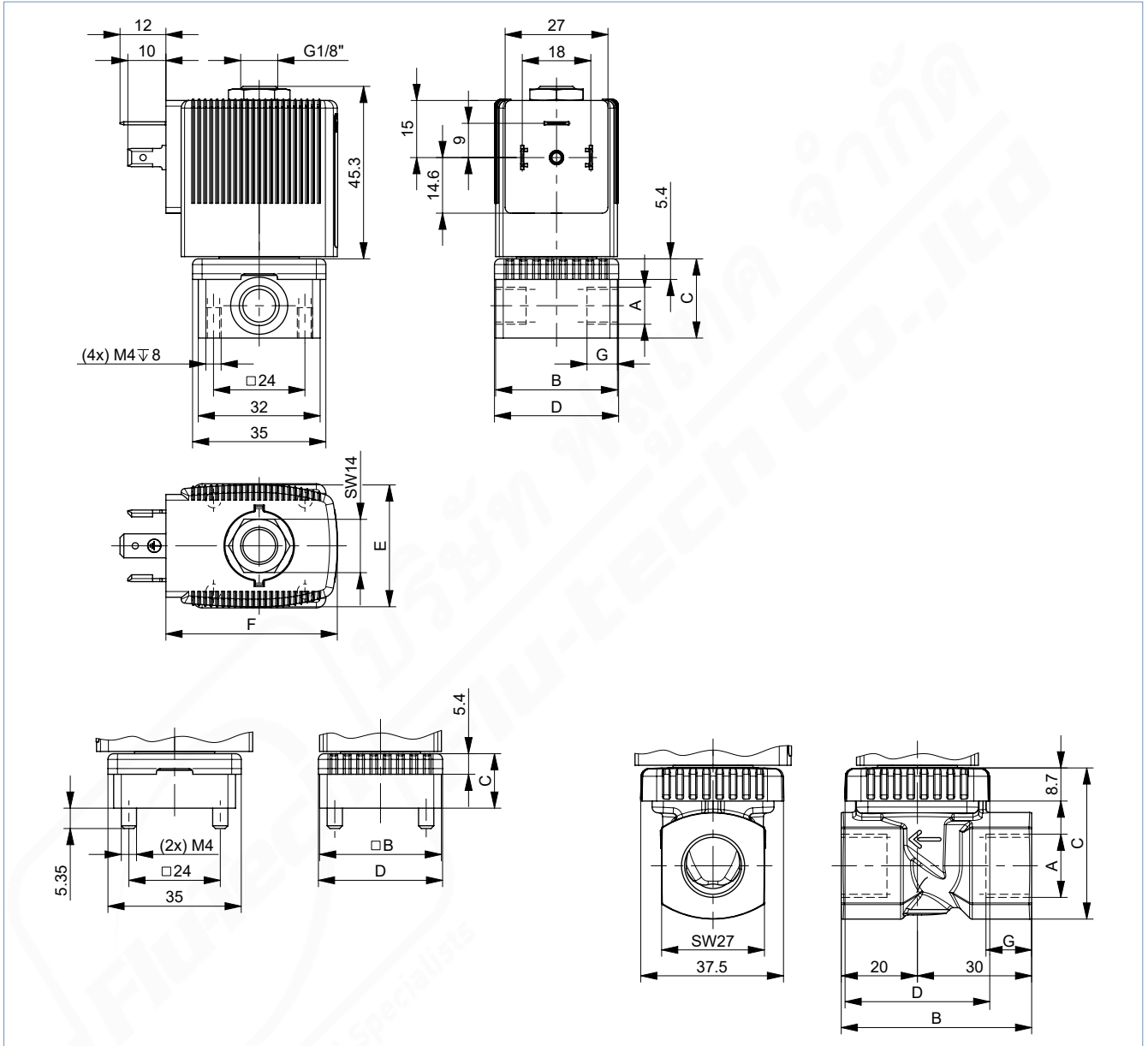

Port connection	A [inch]	B [mm]	C [mm]	D [mm]	G [mm]
Thread	G/NPT 1/8	32	20.8	32.6	8
	G/NPT 1/4	46	26.8	49	12
	G/NPT 3/8	50	39.8	38	12
Flange	-	32	14.3	32.6	-

Coil size	E	F
	[mm]	[mm]
5	32	45
6	40	51

5.2. ATEX/IECEX cable version

Note:

Dimensions in mm

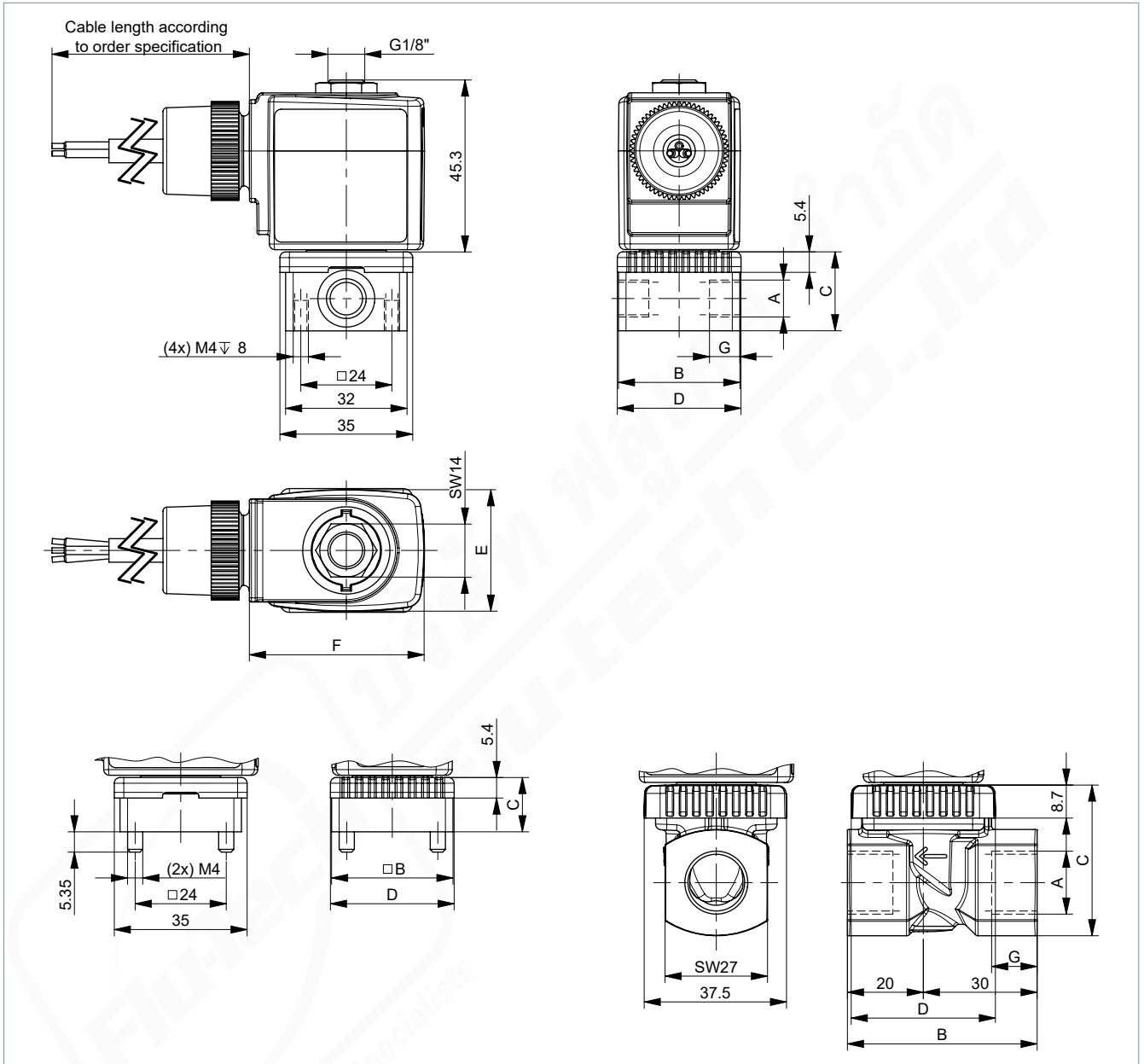

Port connection	A [inch]	B [mm]	C [mm]	D [mm]	G [mm]
Thread	G/NPT 1/8	32	20.8	32.6	8
	G/NPT 1/4	46	26.8	49	12
	G/NPT 3/8	50	39.8	38	12
Flange	-	32	14.3	32.6	-

Coil size	E [mm]	F [mm]
5	32	46
6	40	52

5.3. ATEX/IECEx terminal box version

Note:  
Dimensions in mm

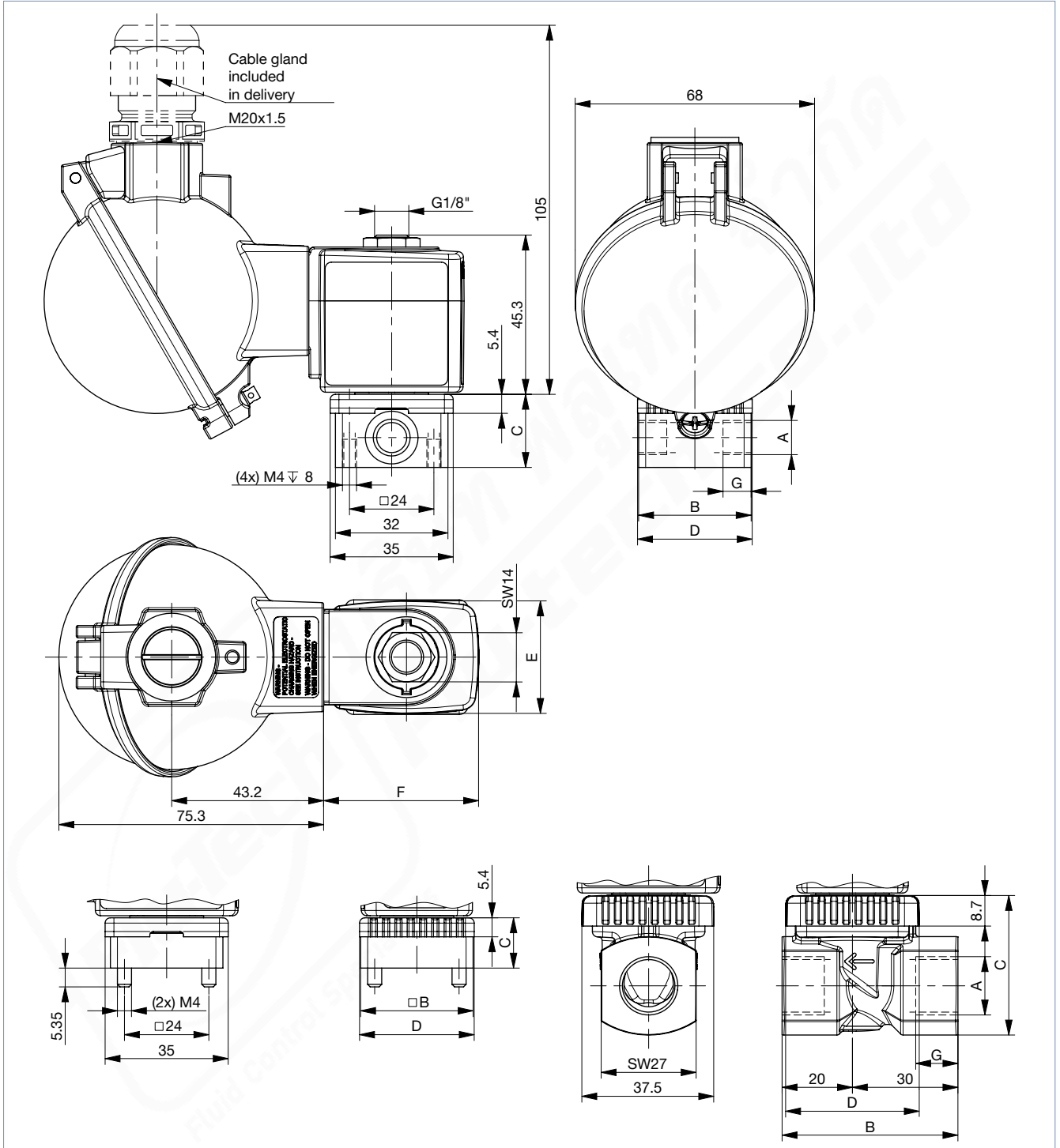

DTS 1000011032 EN Version: AK Status: RL (released | freigegeben | valide) printed: 20.03.2024

Port Connection	A	B	C	D	H
	[inch]	[mm]	[mm]	[mm]	[mm]
Thread	G/NPT 1/8	32	20.8	32.6	8
	G/NPT 1/4	46	26.8	49	12
	G/NPT 3/8	50	39.8	38	12
Flange	-	32	14.3	32.6	-

Coil size	E	F
	[mm]	[mm]
5	32	44
6	40	51

#### 5.4. Single manifold

**Note:**

- Dimensions in mm
- Refer to **"5.6. Manifolds for block mounting"** on page 15 for more information about the installation of manifolds.

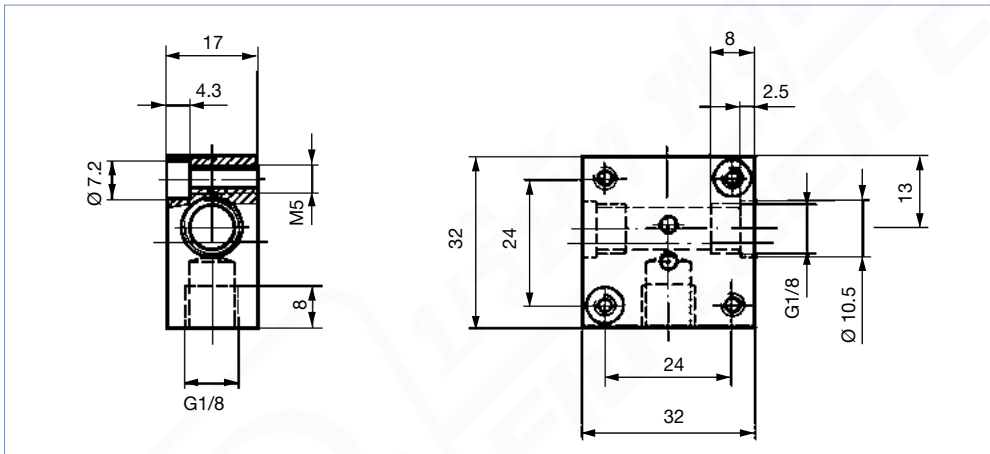

### 5.5. Multiple manifold

**Note:**

- Dimensions in mm
- The manifold is only possible with coil size 5.
- Brass or stainless steel manifold is available on request.

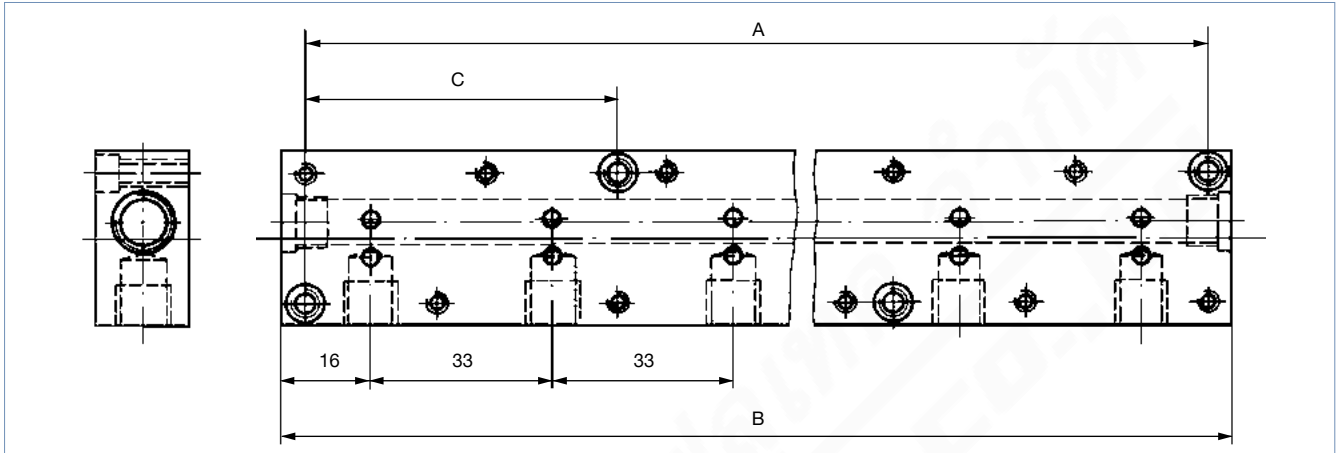

Accessory part	Quantity of valve places	Hole spacing A		Total length B		Hole spacing C		Article no.
		[mm]	[inch]	[mm]	[inch]	[mm]	[inch]	
Multiple manifold (in aluminium)	2	57	2.24	65	2.56	-	-	005023
	3	90	3.54	98	3.86	-	-	005286
	4	123	4.84	131	5.16	-	-	005287
	5	156	6.14	164	6.46	57	2.24	005035
	6	189	7.44	197	7.76	57	2.24	005038
	8	255	10.04	263	10.35	90	3.54	005386
	10	321	12.64	329	12.95	90	3.54	005764
Single manifold (in aluminium)								005020
Connector nipple with O-ring to connect from manifold								005040
Covering plate with screws and O-ring for locking unoccupied valve positions								005630

### 5.6. Manifolds for block mounting

**Note:**

- Close open ports for valves that are not required with cover plates (see accessories).
- Fasten the manifolds to a standard rail.
- Refer to chapter “5.5. Multiple manifold” on page 15 for more information about the dimensions.

With manifold mounting, please comply with the permissible duty cycle (5 W models with 100 % continuous rating or standard 8 W model with 60 % duty cycle). The pressure port for the manifold is designated with P (R) and the outlet port with A (B). Only connect together ports with the same designation.

2/2-way valves of Type 6013 can be operated together on a manifold with 3/2-way valves of Type 6014, circuit function C (not D or T!) if the operating pressures matches according to the rating plates. The manifolds can also be expanded if the valve functions are taken into consideration. Connector nipples with O-rings are used to connect the P (R) ports.

DTS 1000011032 EN Version: AK Status: RL (released | freigegeben | valide) printed: 20.03.2024

## 6. Performance specifications

### 6.1. Power consumption

#### Circuit function A

Orifice [mm]	Port connection	K <sub>v</sub> value water [m <sup>3</sup> /h]	Weight [g]	Power consumption <sup>1.)</sup> [W]	Electrical power		Coil size	Switching times	
					Inrush AC [VA]	Hold AC [VA]		Opening [ms]	Closing [ms]
2.0	G 1/8	0.12	325	8 W AC or 8 W DC (9)	24	17	5 (32 mm)	20	30
2.0	G 1/4	0.12	465	8 W AC or 8 W DC (9)	24	17	5 (32 mm)	20	30
2.0	Flange	0.12	290	8 W AC or 8 W DC (9)	24	17	5 (32 mm)	20	30
2.5	G 1/8	0.16	325	8 W AC or 8 W DC (9)	24	17	5 (32 mm)	20	30
2.5	G 1/4	0.16	465	8 W AC or 8 W DC (9)	24	17	5 (32 mm)	20	30
3.0	G 1/8	0.23	325	8 W AC or 8 W DC (9)	24	17	5 (32 mm)	20	30
3.0	G 1/4	0.23	465	8 W AC or 8 W DC (9)	24	17	5 (32 mm)	20	30
3.0	G 3/8	0.23	550	10 W AC or 10 W DC (11)	30	22	6 (40 mm)	20	30
4.0	G 1/4	0.30	465	8 W AC or 8 W DC (9)	24	17	5 (32 mm)	20	30
4.0	G 3/8	0.30	550	10 W AC or 10 W DC (11)	30	22	6 (40 mm)	20	30
6.0	G 1/4	0.55	465	8 W AC or 8 W DC (9)	24	17	5 (32 mm)	20	30
6.0	G 3/8	0.55	550	10 W AC or 10 W DC (11)	30	22	6 (40 mm)	20	30

1.) The values in brackets correspond to a coil temperature of +20 °C.

#### Circuit function B

Orifice [mm]	Port connection	K <sub>v</sub> value water [m <sup>3</sup> /h]	Weight [g]	Power consumption <sup>1.)</sup> [W]	Electrical power		Coil size	Switching times	
					Inrush AC [VA]	Hold AC [VA]		Opening [ms]	Closing [ms]
2.00	G 1/8	0.12	325	7 W AC or 8 W DC (9)	24	17	5 (32 mm)	20	30
2.00	G 1/4	0.12	465	7 W AC or 8 W DC (9)	24	17	5 (32 mm)	20	30
2.00	Flange	0.12	290	7 W AC or 8 W DC (9)	24	17	5 (32 mm)	20	30
3.00	G 1/8	0.23	325	7 W AC or 8 W DC (9)	24	17	5 (32 mm)	20	30
3.00	G 1/4	0.23	465	7 W AC or 8 W DC (9)	24	17	5 (32 mm)	20	30
3.00	Flange	0.23	290	7 W AC or 8 W DC (9)	24	17	5 (32 mm)	20	30
4.00	G 1/4	0.3	465	7 W AC or 8 W DC (9)	24	17	5 (32 mm)	20	30
6.00	G 1/4	0.55	465	7 W AC or 8 W DC (9)	24	17	5 (32 mm)	20	30

1.) The values in brackets correspond to a coil temperature of +20 °C.



## 7. Product installation

### 7.1. Installation notes

#### Control for impulse version with polarity reversal control

**Note:**

- Use cable plug without electrical wiring exclusively for impulse version.
- Pulse duration min. 50 ms

Polarity (is marked on the coil with a label)	Features	Terminal connections
- switch ON +	valve open	(+) on terminal 2 and (-) on terminal 1 (see below)
+ switch OFF -	valve closed	(+) on terminal 1 and (-) on terminal 2 (see below)





## 8. Product accessories

### 8.1. Cable glands for ATEX/IECEX terminal box

**Note:**

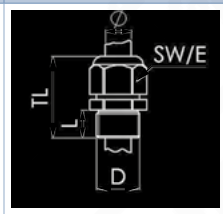
A cable gland in polyamide version is included in the delivery. A nickel-plated brass version can be ordered at a surcharge, see “9.5. Ordering chart accessories” on page 24.

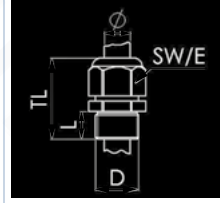
Description	Ex approvals		Dimensions										
	Certification	Identification											
Ex cable gland, Nickel-plated brass, 6...13 mm 	PTB 04 ATEX 1112 X, IECEX PTB 13.0027X	II 2 G Ex e IIC Gb, II 2 D Ex tb IIIC Db IP68	 <table border="1"> <tr><td>TL</td><td>29...37 mm</td></tr> <tr><td>L</td><td>6 mm</td></tr> <tr><td>D</td><td>20 mm</td></tr> <tr><td>SW</td><td>24 mm</td></tr> <tr><td>E</td><td>27 mm</td></tr> </table>	TL	29...37 mm	L	6 mm	D	20 mm	SW	24 mm	E	27 mm
TL	29...37 mm												
L	6 mm												
D	20 mm												
SW	24 mm												
E	27 mm												
Ex cable gland, Polyamide, 7...13 mm 	PTB 13 ATEX 1015 X, IECEX PTB 13.0034X	II 2 G Ex e IIC Gb, II 2 D Ex tb IIIC Db IP68	 <table border="1"> <tr><td>TL</td><td>36...45 mm</td></tr> <tr><td>L</td><td>10 mm</td></tr> <tr><td>D</td><td>20 mm</td></tr> <tr><td>SW</td><td>24 mm</td></tr> <tr><td>E</td><td>28 mm</td></tr> </table>	TL	36...45 mm	L	10 mm	D	20 mm	SW	24 mm	E	28 mm
TL	36...45 mm												
L	10 mm												
D	20 mm												
SW	24 mm												
E	28 mm												

### 8.2. Special tool to turn the terminal box

**Note:**

This special tool is not supplied with the valve, see “9.5. Ordering chart accessories” on page 24.

Description	Components of the set
Set SC02-AC10 	<ul style="list-style-type: none"> <li>• Special wrench</li> <li>• Service manual</li> </ul>

DTS 1000011032 EN Version: AK Status: RL (released | freigegeben | valide) printed: 20.03.2024

## 9. Ordering information

### 9.1. Bürkert eShop



#### Bürkert eShop – Easy ordering and quick delivery

You want to find your desired Bürkert product or spare part quickly and order directly? Our online shop is available for you 24/7. Sign up and enjoy all the benefits.

[Order online now](#)

### 9.2. Bürkert product filter



#### Bürkert product filter – Get quickly to the right product

You want to select products comfortably based on your technical requirements? Use the Bürkert product filter and find suitable articles for your application quickly and easily.

[Try out our product filter](#)

### 9.3. Bürkert Product Enquiry Form

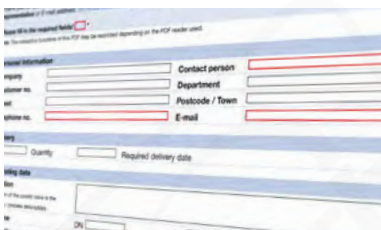

#### Bürkert Product Enquiry Form – Your enquiry quickly and compactly

Would you like to make a specific product enquiry based on your technical requirements? Use our Product Enquiry Form for this purpose. There you will find all the relevant information for your Bürkert contact. This will enable us to provide you with the best possible advice.

[Fill out the form now](#)

9.4. Ordering chart

Standard version

Note:

Please note that the cable plug must be ordered separately, see “Cable plug Type 2518, form A according to DIN EN 175301 - 803” on page 24 or separate data sheet Type 2518 ▶.

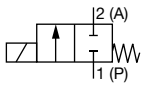
Circuit function	Port connection	Orifice [mm]	K <sub>v</sub> value water <sup>1.)</sup> [m <sup>3</sup> /h]	Voltage/ Frequency [V/Hz]	Coil power [W]	Pressure range <sup>2.)</sup> [bar]	Article no.	Article no.
							Brass body	Stainless steel body
With FKM seal, brass or stainless steel body (class B)								
<b>CF A</b> 2/2-way solenoid valve Direct-acting Normally closed 	G 1/8	2.0	0.12	024/DC	8	0...12	134237	134233
				024/50		0...25	132865	134234
				230/50		0...25	134239	134236
	G 1/4	0.12	024/DC	8	0...12	137537	137533	
			024/50		0...25	137538	137534	
			230/50		0...25	137540	137536	
	Flange (SFB)	0.12	024/DC	8	0...12	134244	145954	
			024/50		0...25	134245	-	
			230/50		0...25	20022979	-	
	G 1/8	2.5	0.16	024/DC	8	0...10	134240	437352
				024/50		0...16	134241	-
				230/50		0...16	134243	-
	G 1/8	3.0	0.23	024/DC	8	0...6	126091	126078
				024/50		0...10	126092	126079
				230/50		0...10	126094	126081
	G 1/4	0.23	024/DC	8	0...6	125301	125317	
			024/50		0...10	125302	126082	
			230/50		0...10	125304	126084	
	G 3/8	0.23	024/DC	10	0...8	134248	-	
			024/50		0...14	134249	-	
			230/50		0...14	134251	-	
	G 1/4	4.0	0.30	024/DC	8	0...1.5	125306	125318
				024/50		0...4	125307	125319
				230/50		0...4	125309	125320
G 3/8	0.30	024/DC	10	0...2.5	134252	-		
		024/50		0...6	134253	-		
		230/50		0...6	134255	-		
G 1/4	6.0	0.55	024/DC	8	0...0.5	125311	126086	
			024/50		0...1.5	125312	126087	
			230/50		0...1.5	125314	126089	
G 3/8	0.55	024/DC	10	0...0.75	134256	-		
		024/50		0...2.5	134257	-		
		230/50		0...2.5	134259	-		

-- = not available

DTS 1000011032 EN Version: AK Status: RL (released | freigegeben | valide) printed: 20.03.2024

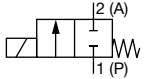
Circuit function	Port connection	Orifice	K <sub>v</sub> value water <sup>1.)</sup>	Voltage/Frequency	Coil power [W]	Pressure range <sup>2.)</sup> [bar]	Article no.
		[mm]	[m <sup>3</sup> /h]	[V/Hz]			
<b>For high temperature applications (- 40 °C...+ 180 °C), PTFE seat seal, brass body (class H)</b>							
<b>CF A</b> 2/2-way solenoid valve Direct-acting Normally closed 	G ¼	2.0	0.12	024/DC	8	0...12	136015 ☒
				024/50		0...25	136016 ☒
				230/50		0...25	136018 ☒
	G ¼	3.0	0.23	024/DC	10	0...6	136019 ☒
				024/50		0...10	136020 ☒
				230/50		0...10	136022 ☒
	G ⅜		0.23	024/DC	10	0...8	136023 ☒
				024/50		0...14	136024 ☒
				230/50		0...14	136026 ☒

1.) Measurement at +20 °C, 1 bar<sup>2.)</sup> at the valve inlet and free outlet  
 2.) Pressure data: overpressure to atmospheric pressure

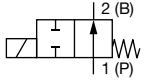
Circuit function	Port connection	Orifice	K <sub>v</sub> value water <sup>1.)</sup>	Voltage/Frequency	Coil power [W]	Pressure range <sup>2.)</sup> [bar]	Article no.
		[mm]	[m <sup>3</sup> /h]	[V/Hz]			
<b>With FKM seal and brass body (class H)</b>							
<b>CF B</b> 2/2-way solenoid valve Direct-acting Normally open 	G ⅝	2.0	0.12	024/DC	8	0...16	213543 ☒
				230/50			7
	G ⅝	3.0	0.23	024/DC	8	0...8	213545 ☒
				230/50			7
	G ¼		0.23	024/DC	8	0...8	213546 ☒
				230/50			7
	G ¼	4.0	0.3	0024/DC	8	0...4	213548 ☒
				230/50			7
	G ¼	6.0	0.55	0024/DC	8	0...2	213549 ☒
				230/50			7

1.) Measurement at +20 °C, 1 bar<sup>2.)</sup> at the valve inlet and free outlet  
 2.) Pressure data: overpressure to atmospheric pressure

**Impulse version**

**Note:**

Please note that the cable plug must be ordered separately, see **“Cable plug Type 2518, form A according to DIN EN 175301 - 803” on page 24** or separate data sheet **Type 2518** ▶.

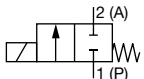
Circuit function	Port connection	Orifice	K <sub>v</sub> value water <sup>1.)</sup>	Pressure range <sup>2.)</sup>	Power consumption DC (hot/cold coil) [W]	Article no.	
		[mm]	[m <sup>3</sup> /h]	[bar]		012/DC [V/Hz]	024/DC [V/Hz]
<b>With FKM seal and brass body (class H)</b>							
<b>CF A</b> 2/2-way solenoid valve Direct-acting Normally closed 	Flange (SFB)	2.0	0.12	0...16	7	209266 ☒	209272 ☒
		2.5	0.16	0...10		209267 ☒	209273 ☒
		3.0	0.23	0...6		209268 ☒	209274 ☒
	G ⅝	2.0	0.12	0...16	7	209269 ☒	209275 ☒
		2.5	0.16	0...10		209270 ☒	209276 ☒
		3.0	0.23	0...6		209271 ☒	209277 ☒

1.) Measurement at +20 °C, 1 bar<sup>2.)</sup> at the valve inlet and free outlet  
 2.) Pressure data: overpressure to atmospheric pressure

DTS 1000011032 EN Version: AK Status: RL (released | freigegeben | valide) printed: 20.03.2024

**Analytical version**

**Note:**

Please note that the cable plug must be ordered separately, see [“Cable plug Type 2518, form A according to DIN EN 175301 - 803” on page 24](#) or separate data sheet [Type 2518](#) ▶.

Circuit function	Port connection	Orifice	K <sub>v</sub> value water <sup>1.)</sup>	Voltage/ Frequency	Coil power	Pressure range <sup>2.)</sup>	Article no.
		[mm]	[m <sup>3</sup> /h]				
<b>With FKM seal and brass body (class B)</b>							
<b>CF A</b> 2/2-way solenoid valve Direct-acting Normally closed 	G 1/8	2.0	0.12	024/DC	8	0...12	137826 ☒
				230/50		0...25	137827 ☒
	G 1/8	2.5	0.16	024/DC	8	0...10	137828 ☒
				230/50		0...16	137829 ☒
	G 1/4	3.0	0.23	024/DC	8	0...6	137830 ☒
				230/50		0...10	137831 ☒
	G 1/4	4.0	0.30	024/DC	8	0...1.5	137832 ☒
				230/50		0...4	137833 ☒
<b>With FKM seal and stainless steel body (class B)</b>							
<b>CF A</b> 2/2-way solenoid valve Direct-acting Normally closed 	G 1/8	2.0	0.12	024/DC	8	0...12	137818 ☒
				230/50		0...25	137819 ☒
	G 1/4	2.0	0.12	024/DC	8	0...12	137820 ☒
				230/50		0...25	137821 ☒
	G 1/4	3.0	0.23	024/DC	8	0...6	137822 ☒
				230/50		0...10	137823 ☒
	G 1/4	4.0	0.30	024/DC	8	0...1.5	137824 ☒
				230/50		0...4	137825 ☒

1.) Measurement at +20 °C, 1 bar<sup>2.)</sup> at the valve inlet and free outlet

2.) Pressure data: overpressure to atmospheric pressure

**DVGW version**

Circuit function	Port connection	Orifice	K <sub>v</sub> value water <sup>1.)</sup>	Voltage/ Frequency	Coil power	Pressure range <sup>2.)</sup>	Article no.
		[mm]	[m <sup>3</sup> /h]				
<b>With NBR seal, brass body (class B)</b>							
<b>CF A</b> 2/2-way solenoid valve Direct-acting Normally closed 	G 1/4	3.0	0.23	024/DC	8	0...5	258362 ☒
				230/50		0...5	296548 ☒
	G 1/4	4.0	0.3	024/DC	8	0...1.5	258361 ☒
				230/50		0...4	296549 ☒
	G 1/4	6.0	0.55	024/DC	8	0...0.15	266293 ☒
				230/50		0...1.5	301072 ☒

1.) Measurement at +20 °C, 1 bar<sup>2.)</sup> at the valve inlet and free outlet

2.) Pressure data: overpressure to atmospheric pressure

DTS 1000011032 EN Version: AK Status: RL (released | freigegeben | valide) printed: 20.03.2024

**ATEX/IECEX cable version**

**Note:**

- The maximum medium temperature must never exceed the permitted temperature class (T4: +135 °C, T5: +100 °C, T6: +85 °C) minus 5 K.
- With 3 m cable as standard. Other lengths are available on request.

Circuit function	Port connection	Orifice	K <sub>v</sub> value water <sup>1.)</sup>	Voltage/ Frequency	Coil power	Pressure range <sup>2.)</sup>	Article no.			
		[mm]	[m <sup>3</sup> /h]				Brass body	Stainless steel body		
<b>Ex m T4 approved, with FKM seal and molded cable (3 m), single mounting only</b>										
<b>CF A</b> 2/2-way solenoid valve Direct-acting Normally closed 	manifold (SFB)	2.0	0.11	024/AC/DC	7	0...6	351923	351915		
				230/AC/DC			364417	o. r.		
	G 1/8	2.5	0.12	024/AC/DC	9	0...10	351895	351900		
				230/AC/DC			o. r.	351926		
	G 1/4			024/AC/DC			9	0...10	351909	351901
				230/AC/DC					351920	351914
	G 1/8	3.0	0.16	024/AC/DC	9	0...8	364430	o. r.		
				230/AC/DC			o. r.	o. r.		
	G 1/8	4.0	0.23	024/AC/DC	9	0...5	o. r.	351933		
				230/AC/DC			o. r.	o. r.		
	G 1/4			024/AC/DC			9	0...5	351896	351899
				230/AC/DC					351925	351936
G 1/4	6.0	0.30	024/AC/DC	9	0...1.2	351921	364523			
			230/AC/DC			o. r.	364528			
G 1/4		0.55	024/AC/DC	9	0...0.4	351902	351948			
			230/AC/DC			364517	o. r.			

o. r. = on request

**ATEX/IECEX terminal box version**

**Note:**

The maximum medium temperature must never exceed the permitted temperature class (T4: +135 °C, T5: +100 °C, T6: +85 °C) minus 5 K.

Circuit function	Port connection	Orifice	K <sub>v</sub> value water <sup>1.)</sup>	Voltage/ Frequency	Coil power	Pressure range <sup>2.)</sup>	Article no.		
		[mm]	[m <sup>3</sup> /h]				Brass body	Stainless steel body	
<b>Ex m T4 approved, with FKM seal and molded cable (3 m), single mounting only</b>									
<b>CF A</b> 2/2-way solenoid valve Direct-acting Normally closed 	manifold (SFB)	1.5	0.08	024/AC/DC	9	0...16	364529	o. r.	
	G 1/8	2	0.12	024/AC/DC			0...10	351938	351953
				230/AC/DC				364533	364537
	G 1/4	024/AC/DC	351944	351917					
	230/AC/DC	364538	351929						

DTS 1000011032 EN Version: AK Status: RL (released | freigegeben | validé) printed: 20.03.2024

Circuit function	Port connection	Orifice	K <sub>v</sub> value water <sup>1)</sup>	Voltage/ Frequency	Coil power	Pressure range <sup>2)</sup>	Article no.	
		[mm]	[m <sup>3</sup> /h]				Brass body	Stainless steel body
<b>CF A</b> 2/2-way solenoid valve Direct-acting Normally closed 	G 1/8	3	0.23	024/AC/DC	9	0...5	364540	o. r.
				230/AC/DC			o. r.	
				024/AC/DC			o. r.	
				230/AC/DC			351906	
	G 1/4	4	0.3	024/AC/DC	9	0...1.2	351941	364544
				230/AC/DC			o. r.	
				024/AC/DC			364551	364554
				230/AC/DC			364555	364556
	G 3/8	6	0.55	024/AC/DC	9	0...0.4	364551	364554
				230/AC/DC			364555	364556

o. r. = on request

Further versions on request	
<b>Approval</b> Further information can be found in chapter “3. Approvals and conformities” on page 6.	<b>Pressure</b> Variants with increased coil power for higher medium pressure
<b>Material</b> Seal material EPDM	<b>Process connection</b> Threaded port NPT, Rc
<b>Voltage</b> Further voltages on request	

### 9.5. Ordering chart accessories

#### Singel manifold

**Note:**

Refer to chapter “5.4. Single manifold” on page 14 for more order information.

#### Multiple manifold

**Note:**

Refer to chapter “5.5. Multiple manifold” on page 15 for more order information.

#### Cable plug Type 2518, form A according to DIN EN 175301 - 803

**Note:**

- Dimensions in mm
- For further versions see data sheet **Type 2518** ▶.

Cable plug	Dimensions	Version	Voltage	Article no.
		Without circuitry (AC/DC)	0...250 V AC/DC	314802
		With LED (AC/DC)	12...24 V AC/DC	314812
		With LED and varistor (AC/DC)	12...24 V AC/DC	314820
		With rectifier, LED and varistor	12...24 V AC/DC	314816
		Without circuitry (AC/DC) with silicone seal for higher ambient temperature, e.g. steam version (NA07)	0...250 V AC/DC	361687

DTS 1000011032 EN Version: AK Status: RL (released | freigegeben | valide) printed: 20.03.2024



**Cable plug Type 2509, form A according to DIN EN 175301 - 803**

**Note:**

- Dimensions in mm
- Without circuitry (Standard)
- Refer to data sheet **Type 2509** ▶ for more information about the cable plug.

Cable plug	Dimensions	Version	Voltage	Article no.
		Without circuitry	0...250 V AC/DC	137943 𐌆

**Cable glands for ATEX/IECEx terminal box**

**Note:**

- A cable gland in polyamide version is included in the delivery. A nickel-plated brass version can be ordered at surcharge.
- Refer to **"8.1. Cable glands for ATEX/IECEx terminal box"** on page 18 for more information about Ex cable glands.
- Refer to **"8.2. Special tool to turn the terminal box"** on page 18 for more information about special wrench.

Description	Article no.
Ex cable gland, nickel-plated brass, 6...13 mm <sup>1.)</sup>	773278 𐌆
Ex cable gland, polyamide, 7...13 mm <sup>1.)</sup>	773277 𐌆
Set SC02-AC10: special wrench <sup>2.)</sup> incl. service manual	293488 𐌆

1.) Cable diameter

2.) Not included in the scope of delivery of the valve