



Electromotive 2/2-way diaphragm valve (ON/OFF)

- Safety position through energy storage
- Adjustable driving force
- Diagnostic functions and fieldbus connection
- Product wetted surfaces in Ra ≤ 0.38 µm...1.6 µm (optionally electropolished)
- Available in port connection sizes DN 06...DN 100

Product variants described in the data sheet may differ from the product presentation and description.

Can be combined with

	Type 3363 Electromotive 2-way diaphragm control valve	▶
	Type 3361 Electromotive 2-way globe control valve	▶
	Type 8098 FLOWave SAW flowmeter	▶

Type description

The externally controlled diaphragm valve Type 3323 consists of an electricaly controlled linear actuator (open/close), of a diaphragm and a 2/2-way valve housing. The electric actuator with recirculating ball screw ensures use under hygienic or aggressive environmental conditions. The flow-favorable and dead space-free valve housings enable high flow values and a wide range of possible uses. In the event of a power failure, the safety position is guaranteed by an optional energy storage device. The position is displayed by means of a 360° LED light ring. To protect the diaphragm the actuator has a drive force adjustment. A correspondingly high IP protection IP65/IP67 ensures adequate splash protection. The electromotive actuator of the diaphragm valve with ball screw moves to the desired end position at a particularly high speed up to 4 mm/s. In addition the valve is also equipped with a mechanical position indicator and a corresponding explosion protection ATEX/II 3G Ex ec IIC T4 Gc/II 3D Ex tc IIIC T135 °C Dc.



Table of contents

1. General technical data	3
2. Approvals	5
3. Materials	6
3.1. Bürkert resistApp	6
3.2. Pressure temperature diagram for plastic body	6
3.3. Material specifications	7
3.4. Example of available membrane materials	7
4. Dimensions	8
4.1. Actuator	8
AG2	8
AG3	9
4.2. Forged body (VS) with welded connection	10
4.3. Forged body (VS) with clamp connection	12
4.4. Tube valve body (VP) with welded connection	14
4.5. Tube valve body (VP) with clamp connection	15
4.6. Tube valve body (VP) with threaded connection	16
4.7. Tube valve body (VP) with flange connection	17
4.8. Cast body (VG) with welded connection	18
4.9. Cast body (VG) with clamp connection	20
4.10. Plastic body (PV, PD, PP) with spigot connections	21
4.11. Plastic body (PV, PD, PP) with true union	22
4.12. Plastic body (PV, PD, PP) with flange connection	23
5. Performance specifications	24
5.1. Fluidic Data	24
Flow characteristics	24
5.2. Operating limits	25
Medium pressure	25
Operating limits for ambient and medium temperature	26
5.3. Electrical control and interfaces	27
Interface diagram	27
6. Product design and assembly	28
6.1. Product features	28
6.2. Product assembly	30
Structure, electromotive diaphragm control valve AG2	30
Structure electromotive diaphragm control valve AG3	31
7. Ordering information	31
7.1. Bürkert eShop	31
7.2. Bürkert product filter	31
7.3. Ordering chart accessories	32
Standard accessories	32
Accessories cable	32
Bürkert accessories	32
7.4. Bürkert Product Enquiry Form	32

1. General technical data

Note:

- AG2: Actuator size 2 with a nominal force of 2500 N for diaphragm size 8...40
- AG3: Actuator size 3 with a nominal force of 11500 N for diaphragm size 40...100

Product properties	
Dimensions	Further information can be found in chapter "4. Dimensions" on page 8.
Material	
Forged body (VS) ¹⁾	Forged stainless steel 316L/1.4435/BN2, Fe <0.5 %/C ≤0.03 %
Stainless steel block material (VI etc.) ¹⁾	Stainless steel 316L/1.4435/BN2, etc.
Tube valve body (VP) ¹⁾	Stainless steel 316L/1.4435/BN2
Cast body (VG) ¹⁾	Cast stainless steel 316L/1.4435
Plastic body (PV, PD, PP) ¹⁾	PVC (PVC-U), PVDF, PP
Diaphragm	EPDM (AD) ¹⁾ , PTFE/EPDM (EA) ¹⁾ , advanced PTFE/EPDM (EU) ¹⁾ , Gylon®/EPDM laminated EPDM (ER) ¹⁾
Design	Diaphragm on/off valve
Diaphragm size	8...100, for plastic body 15...100
Standard surface quality²⁾	
Forged body (VS) ¹⁾	Internally electrically polished: Ra ≤0.38 µm (NO17) ¹⁾ (ASME BPE SF4/DIN HE4) (externally forged surface, electrically polished) Internally mechanically polished: Ra ≤0.5 µm (NO14) ¹⁾ (ASME BPE SF1) (externally forged surface)
Block body (VI etc.) ¹⁾	Internally electrically polished: Ra ≤0.38 µm (NO17) ¹⁾ (ASME BPE SF4/DIN HE4) (externally electrically polished) Internally mechanically polished: Ra ≤0.5 µm (NO14) ¹⁾ (ASME BPE SF1) (externally mechanically machined)
Tube valve body (VP) ¹⁾	Internally electrically polished: Ra ≤0.38 µm (NO17) ¹⁾ (ASME BPE SF4/DIN HE4) (externally electrically polished) Internally glass-bead blasted: Ra ≤1.6 µm (NO05) ¹⁾ (externally glass-bead blasted)
Cast body (VG) ¹⁾	Internally electrically polished: Ra ≤0.6 µm (NO16) ¹⁾ (ASME BPE SF6) (externally cast surface, electrically polished) Internally mechanically polished: Ra ≤0.76 µm (NO06) ¹⁾ (ASME BPE SF3/DIN H2) (externally cast surface)
Safety setting in case of power failure	With SAFEPOS energy-pack: opened, closed or freely programmable Without SAFEPOS energy-pack: blocked in last position
Lifelong energy storage SAFEPOS energy-pack	Up to 10 years (depending on operating conditions)
Performance data	
Closing time	AG2: 1.5...4.5 s AG3: 5.7...12.0 s (Depending on travel speed, stroke and operating conditions)
Travel speed	4 mm/s (for AG2 actuator force 2500 N) 3 mm/s (for AG3 actuator force 11500 N)
Electrical data	
Operating voltage	24 V DC ± 10 % (maximum residual ripple 10 %)
Operating current ³⁾	AG2: Max. 3 A (at maximum load and including 1 A charging current of the optional SAFEPOS energy-pack). At minimum operating temperature additionally 2 A AG3: Max. 5 A (at maximum load and including charging current of the optional SAFEPOS energy-pack). At minimum operating temperature additionally 6 A
Protection class (DIN EN 61140)	3
Duty cycle	100 %
Standby consumption ³⁾	1...5 W
Communication and control	
Digital input for position signal	0...5 V (log. 0) 10...30 V (log. 1)
Fieldbus (digital)	Bürkert system bus (bÜS) CANopen (option) EtherNet/IP, PROFINET, Modbus TCP (option via integrated gateway)

Medium data	
Process medium	Neutral gases and fluids, highly purified, sterile, aggressive or abrasive media (see chemical resistance chart ▶)
Medium temperature	
EPDM (AD) ^{1.)}	-10...+143 °C (steam sterilisation +150 °C for 60 min)
PTFE/EPDM (EA) ^{1.)}	-10...+130 °C (steam sterilisation +140 °C for 60 min)
Advanced PTFE/EPDM (EU) ^{1.)}	-5...+143 °C (steam sterilisation +150 °C for 60 min)
GYLON®/EPDM laminated EPDM (ER) ^{1.)}	-5...+130 °C (steam sterilisation +140 °C for 60 min)
Plastic body	See "3.2. Pressure temperature diagram for plastic body" on page 6
Process/Port connection & communication	
Port connection size	DN 06...DN 100 (1/8" ... 4")
Port connection^{2.)}	
For stainless steel body^{4.)}	
Welded connection ^{2.)}	DIN EN ISO 1127/ISO 4200/DIN 11866 series B DIN 11850 series 2/DIN 11866 series A/DIN EN 10357 series A ASME BPE/DIN 11866 series C
Clamp connection ^{2.)}	DIN 32676 series A (DIN pipe) DIN 32676 series B (ISO pipe) ASME BPE
For plastic body	
Spigot connection	DN 15...DN 50
True union	DN 15...DN 50
Loose flange	DN 15...DN 65
Fixed flange	DN 80...DN 100
Electrical connection	
Actuator	Terminal strip with cable gland (only AG2), 2 x M20 or 2 M12 circular plugs, 5-pin and 8-pin
Fieldbus gateway	2 M12 circular sockets, 4-pin (only with Industrial Ethernet)
Approvals and certificates	
Ignition protection class	II 3G Ex ec IIC T4 Gc II 3D Ex tc IIIC T135 °C Dc
Detergent resistance	According to Ecolab test method: R&D/P3-E No. 40-1
Environment and installation	
Ambient temperature	-10 °C...+65 °C ^{4.)} (without SAFEPOS energy storage) -10 °C...+55 °C ^{4.)} (with SAFEPOS energy storage) Derating see "5.2. Operating limits" on page 25
Degree of protection	IP65/IP67 (DIN EN 60529), NEMA 4X
Installation position	As required, preferably with actuator upright

1.) This information is part of the product key (see **"7.4. Bürkert Product Enquiry Form"** on page 32).

2.) Further port connections on request







3.) All values refer to a supply voltage of 24 V at 25 °C.

4.) Depends on medium temperature, see chapter **"Operating limits for ambient and medium temperature"** on page 26

2. Approvals

Note:

If you need one of these certificates, please contact your Bürkert partner.

Approvals/ Conformity/ Certificate ^{1.)}	Description
	ATEX/IECEX^{2.)} BVS 17 ATEX E 117 X II 3G Ex ec IIC T4 Gc/II 3D Ex tc IIIC T135 °C Dc IECEX BVS 17.0100X Ex ec IIC T4 Gc/Ex tc IIIC T135 °C Dc
	3-A (3-A Sanitary Standards Symbol Administrative Council) ^{3.)}
	The diaphragms made of EPDM (AD), PTFE/EPDM (EA), advanced PTFE/EPDM (EU) and GYLON®/EPDM laminated (ER) are suitable for use with food and beverages (acc. to EC Regulation 1935/2004/EC).
	Diaphragms made of EPDM (AD), PTFE/EPDM (EA), advanced PTFE/EPDM (EU) and GYLON®/EPDM laminated (ER) are acc. to USP Class VI tested.
FDA	Diaphragms made of EPDM (AD), PTFE/EPDM (EA), advanced PTFE/EPDM (EU) and GYLON®/EPDM laminated (ER) comply with the Code of Federal Regulations published by the FDA (Food and Drug Administration, USA).
	Safety requirements UL-listed cULus Cert. No. 238179 (optional)
	Detergent resistance Material compatibility tested with common Ecolab products and certified according to Ecolab test method: R&D/P3-E No. 40-1

1.) Further approvals/conformity clarification on request

2.) Only in combination with variable code "PX48" (see "7.4. Bürkert Product Enquiry Form" on page 32)

3.) Only in combination with variable code "PE05" (see "7.4. Bürkert Product Enquiry Form" on page 32)

3. Materials

3.1. Bürkert resistApp



Bürkert resistApp – Chemical resistance chart

You want to ensure the reliability and durability of the materials in your individual application case? Verify your combination of media and materials on our website or in our resistApp.

[Start chemical resistance check](#)

3.2. Pressure temperature diagram for plastic body

Note:

This information is important for material selection. Observe the permissible operating pressure depending on the medium temperature.

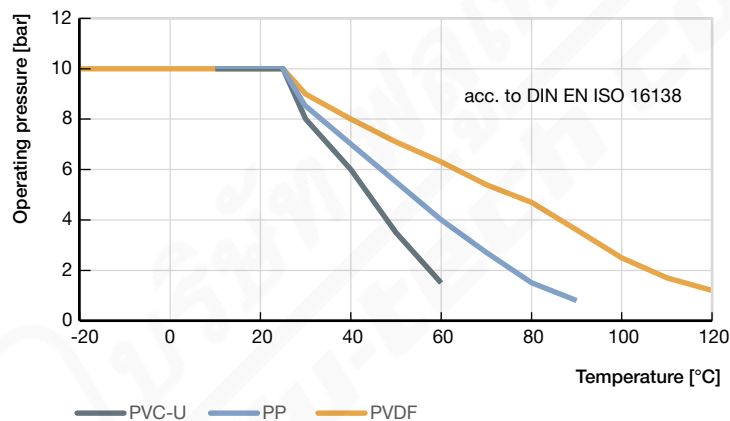

DTS 1000303513 EN Version: R Status: RL (released | freigegeben | validé) printed: 19.09.2023

3.3. Material specifications

Note:

The depiction of the products may differ from the actual specific design (e.g. body material and port connection)

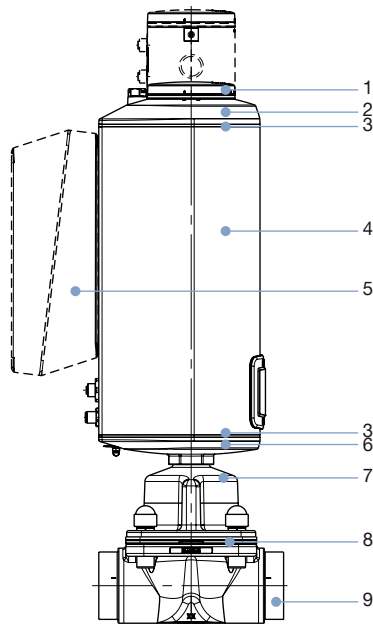

AG2

Nr.	Komponente	Material
1	Blind cover	PPS (standard), Stainless steel 1.4301 (for ATEX/IECEX)
2	Actuator cover	PPS
3	Seal	EPDM
4	Actuator housing	Aluminium, powder coated
6	Actuator base	PPS
7	Diaphragm socket	Stainless steel 1.4308
8	Diaphragm	EPDM (AD) PTFE/EPDM (EA) Advanced PTFE/EPDM (EU) GYLON®/EPDM laminated EPDM (ER)
9	Valve body	See "1. General technical data" on page 3

AG3

Nr.	Komponente	Material
1	Blind cover	PPS (standard), Stainless steel 1.4301 (for ATEX/IECEX)
2	Actuator cover	PC
3	Seal	EPDM
4	Actuator housing	Aluminium, powder coated
5	SAFEPOS energy pack	PC
6	Actuator base	Stainless steel 1.4308
7	Diaphragm socket	Stainless steel 1.4470
8	Diaphragm	EPDM (AD) PTFE/EPDM (EA) Advanced PTFE/EPDM (EU) GYLON®/EPDM laminated EPDM (ER)
9	Valve body	See "1. General technical data" on page 3

3.4. Example of available membrane materials

The diaphragms have been developed to meet the unique challenges of hygienic and sterile requirements. Bürkert offers diaphragms with precise material composition and high accuracy. Bürkert diaphragms are available in a wide range of materials which have been tested and proven in applications in the food and beverage, biotechnology, pharmaceutical and cosmetics industries. The diaphragms are tested during development and production to ensure reliability under difficult process conditions.



- EPDM (AD)
- PTFE/EPDM (EA)
- Advanced PTFE/EPDM (EU)
- Gylon®/EPDM laminated EPDM (ER)

For further information please refer to our flyer "Diaphragm competence for hygienic applications" on our [website](#) ▶

4. Dimensions

4.1. Actuator

AG2

Note:

Dimensions in mm, unless otherwise stated

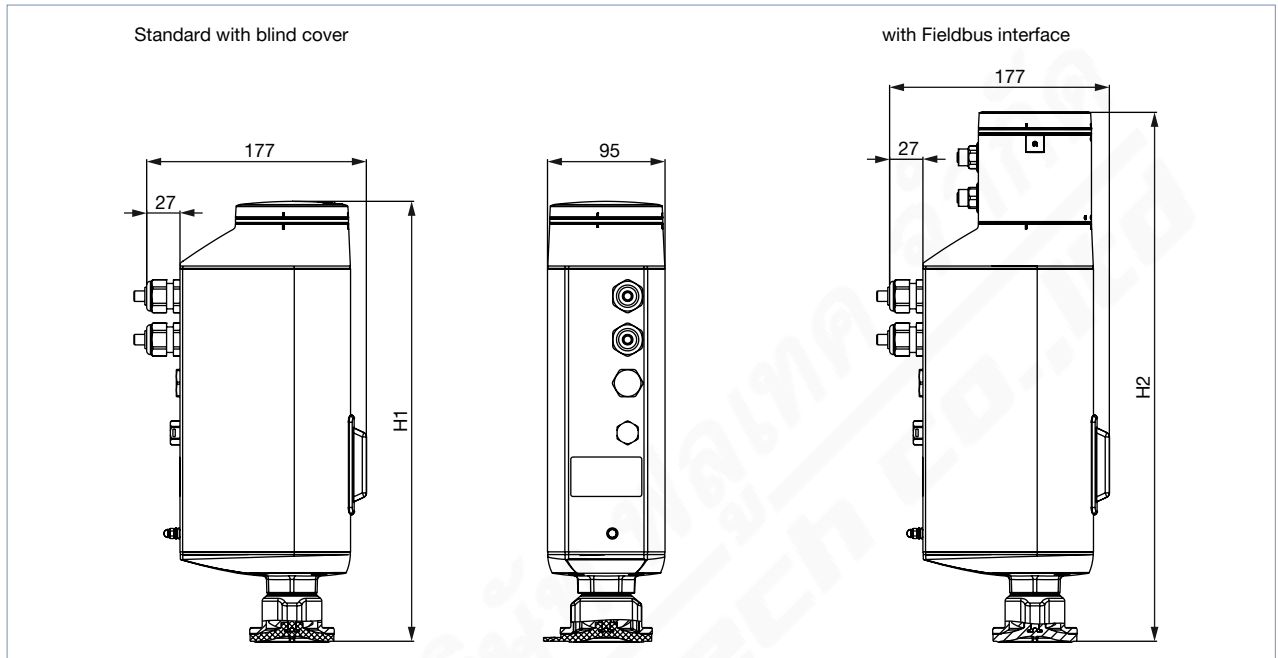

Diaphragm size	Height	
	H1 Standard variant [mm]	H2 ^{1.)} Fieldbus variant (KOMM ≠ G, N, L) [mm]
8	342	414
15	345	418
20	350	422
25	355	426
32	365	436
40	370	442

1.) Option: integrated fieldbus gateway

AG3

Note:

Dimensions in mm, unless otherwise stated

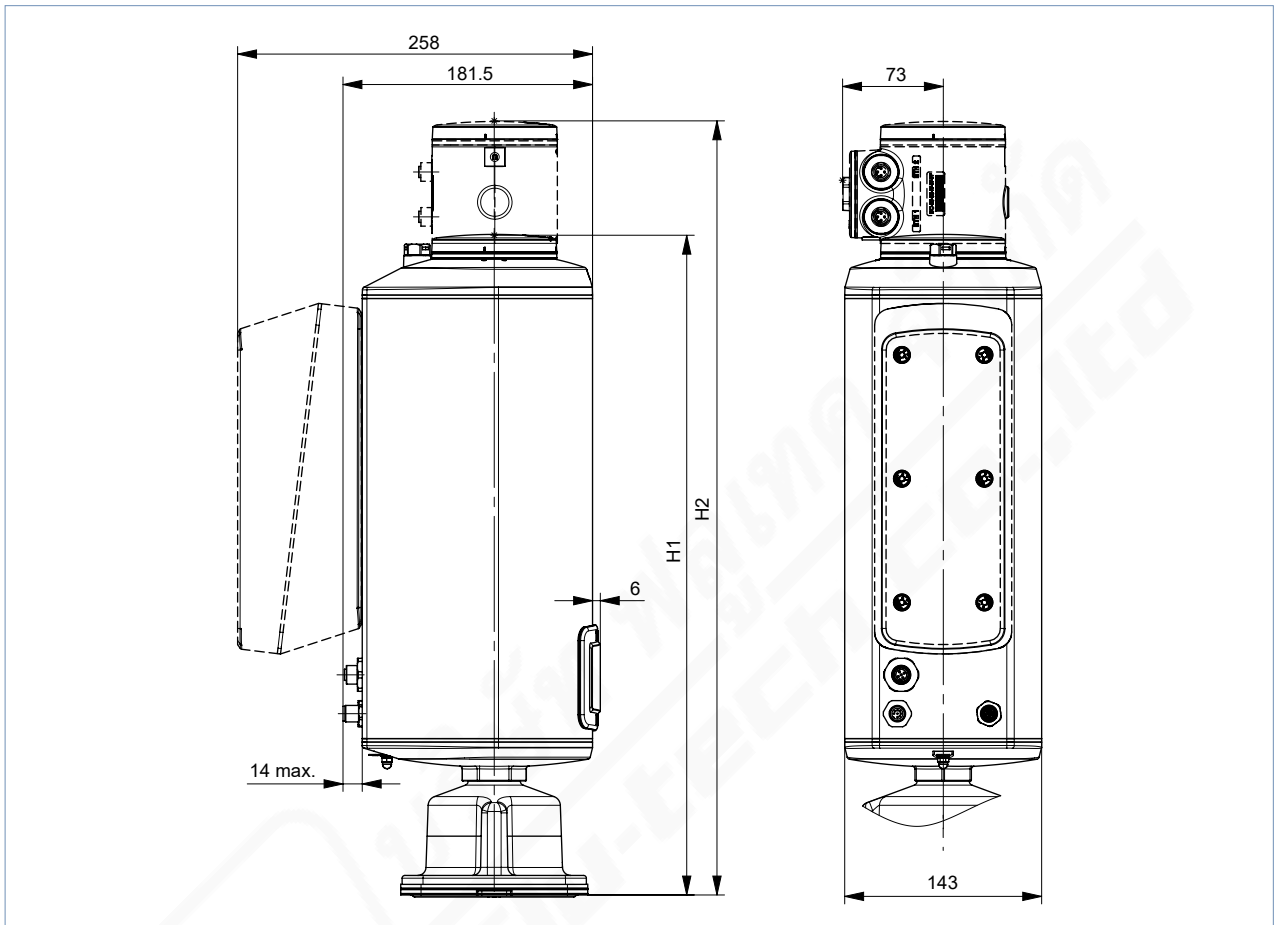

Diaphragm size	Height	
	H1 Standard variant [mm]	H2 ^{1.)} Fieldbus variant (KOMM ≠ G, N, L) [mm]
40	452	523
50	462	533
65	477	548
80	479	550
100	482	553

1.) Option: integrated fieldbus gateway

DTS 1000303513 EN Version: R Status: RL (released | freigegeben | validé) printed: 19.09.2023

4.2. Forged body (VS) with welded connection

Note:

- Dimensions in mm, unless otherwise stated
- Further information on the draining angle, please refer to the “Additional manual Type 2xxx 3xxx” on our website (see [operating instructions Type 3323](#) ▶).

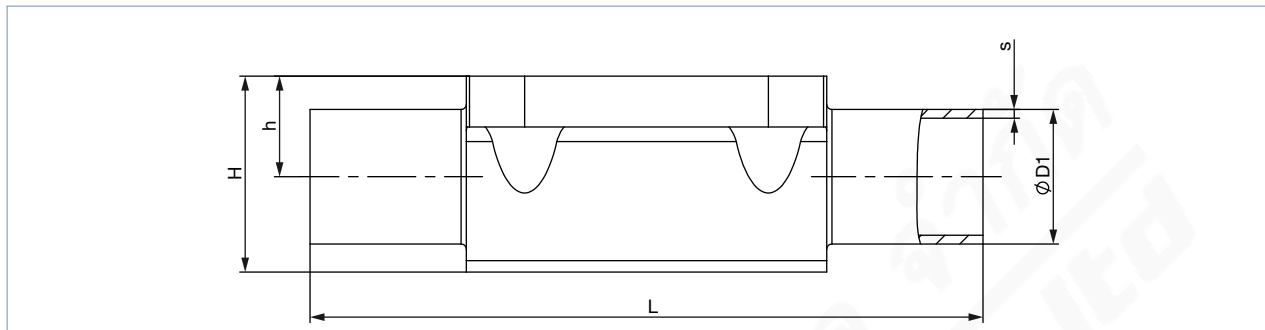

Diaphragm size	Port connection DN	ØD1	s	L	h	H	Product key ¹⁾
DIN EN ISO 1127/ISO 4200/DIN 11866 series B							
8	8	13.50	1.60	90	9.30	18.80	SA40
15	8	13.50	1.60	108	8.15	19.95	SA40
8	10	17.20	1.60	90	9.30	18.80	SA41
15	10	17.20	1.60	110	12.05	23.75	SA41
15	15	21.30	1.60	110	12.05	23.75	SA42
20	15	21.30	1.60	119	16.00	30.30	SA42
20	20	26.90	1.60	119	16.00	30.30	SA43
25	20	26.90	1.60	119	19.00	37.00	SA43
25	25	33.70	2.00	129	19.00	37.00	SA44
40	25	33.70	2.00	161	27.60	52.40	SA44
40	32	42.40	2.00	161	27.60	52.40	SA45
40	40	48.30	2.00	161	27.60	52.40	SA46
50	50	60.30	2.00	192	35.50	68.30	SA47
65	65	76.10	2.00	192	43.00	83.50	SA48
80	65	76.10	2.00	250	51.00	98.10	SA48
80	80	88.90	2.30	250	51.00	98.10	SA49
100 ²⁾	100	114.30	2.30	295	63.50	127.00	SA39
DIN 11850 series 2/DIN 11866 series A/DIN EN 10357 series A							
8	10	13.00	1.50	90	9.30	18.80	SD40
15	10	13.00	1.50	110	8.15	19.85	SD40
15	15	19.00	1.50	110	12.05	23.75	SD42
20	20	23.00	1.50	119	16.00	30.30	SD43
25	25	29.00	1.50	129	19.00	37.00	SD44
40	32	35.00	1.50	161	27.60	52.40	SD45
40	40	41.00	1.50	161	27.60	52.40	SD46
50	50	53.00	1.50	192	35.50	68.30	SD74
65	65	70.00	2.00	192	43.00	83.50	SD48
80	65	70.00	2.00	250	51.00	98.10	SD48
80	80	85.00	2.00	250	51.00	98.10	SD49
100 ²⁾	100	104.00	2.00	295	63.50	127.00	SD50

Diaphragm size	Port connection DN	ØD1	s	L	h	H	Product key ^{1.)}
ASME BPE/DIN 11866 series C							
8	¼"	6.35	0.89	78	5.70	15.20	SA90
8	⅜"	9.53	0.89	89	5.70	15.20	SA91
8	½"	12.70	1.65	89	9.30	18.80	SA92
15	½"	12.70	1.65	108	8.15	19.85	SA92
15	¾"	19.05	1.65	108	12.05	23.75	SA93
20	¾"	19.05	1.65	117	16.00	30.30	SA93
25	1"	25.40	1.65	127	19.00	37.00	SODF
40	1 ½"	38.10	1.65	159	27.60	52.40	SODH
50	2"	50.80	1.65	190	35.50	68.30	SODI
50	2 ½"	63.50	1.65	192	35.50	68.30	SODJ
65	2 ½"	63.50	1.65	192	43.00	83.50	SODJ
80	2 ½"	63.50	1.65	250	51.00	98.10	SODJ
80	3"	76.20	1.65	250	51.00	98.10	SODK
100 ^{2.)}	4"	101.60	2.11	295	63.50	127.00	SODL
BS 4825							
8	8	6.35	1.20	78	5.70	15.20	SODB
8	10	9.53	1.20	89	5.70	15.20	SODC
8	15	12.70	1.20	90	9.30	18.80	SODD
15	15	12.70	1.20	108	8.15	19.85	SODD
20	20	19.05	1.20	117	16.00	30.30	SODE
25	25	25.40	1.65	127	19.00	37.00	SODF
40	40	38.10	1.65	159	27.60	52.40	SODH
50	50	50.80	1.65	190	35.50	68.30	SODI
50	65	63.50	1.65	192	35.50	68.60	SODJ
65	65	63.50	1.65	192	43.00	83.50	SODJ
80	80	63.50	1.65	250	51.00	98.10	SODJ
80	80	76.20	1.65	250	51.00	98.10	SODK
100 ^{2.)}	100	101.60	2.11	295	63.50	127.00	SODL
SMS 3008							
25	25	25.00	1.20	129	19.00	37.00	SA60
40	40	38.00	1.20	161	27.60	52.40	SA62
50	50	51.00	1.20	192	35.50	68.30	SA63
65	65	63.50	1.60	192	43.00	83.50	SA64
DIN 11850 series 0							
8	6	8.00	1.00	90.00	5.7	15.20	SC41
8	8	10.00	1.00	90.00	5.7	15.20	SC42
15	15	18.00	1.50	110	12.00	23.75	SC43
20	20	22.00	1.50	119	16.00	30.30	SC44
40	32	34.00	1.50	161	27.60	52.40	SC46
40	40	40.00	1.50	161	27.60	52.40	SC47
50	50	52.00	1.50	192	35.50	68.30	SC48

1.) This information is part of the product key (see "7.4. Bürkert Product Enquiry Form" on page 32)

2.) Only available as block material

4.3. Forged body (VS) with clamp connection

Note:

- Dimensions in mm, unless otherwise stated
- Further information on the draining angle, please refer to the “Additional manual Type 2xxx 3xxx” on our website (see [operating instructions Type 3323](#) ▶).

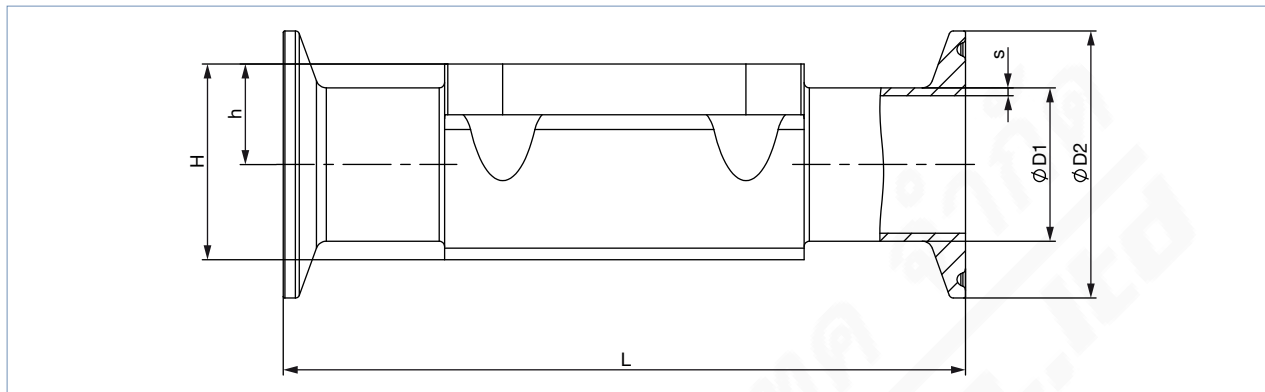

Diaphragm size	Port connection DN	ØD1	s	ØD2	L	h	H	Product key ¹⁾	Variable code ¹⁾
DIN 32676 series B (ISO pipe)									
8	8	13.50	1.60	25.00	90.00	9.30	18.80	TC40	-
8	10	17.20	1.60	25.00	89.00	9.30	18.80	TC53	-
15	8	13.50	1.60	25.00	89.00	8.15	19.85	TC40	-
15	15	21.30	1.60	50.50	167.00	12.05	23.75	TC52	AF79
20	20	26.90	1.60	50.50	114.00	16.00	30.30	TC43	AF79+AG42
25	25	33.70	2.00	50.50	129.00	19.00	37.00	TC44	-
40	40	48.30	2.00	64.00	161.00	27.60	52.40	TC46	-
50	50	60.30	2.00	77.50	190.00	35.50	68.30	TC47	-
65	65	76.10	2.00	91.00	190.00	35.50	68.30	TC48	-
80	80	88.90	2.30	106.00	222.00	51.00	98.10	TC49	-
100 ²⁾	100	114.30	2.30	130.00	350.00	63.50	127.00	TC50	-
DIN 32676 series A (DIN pipe)									
8	6	8.00	1.00	25.00	89.00	5.70	15.20	TD39	-
8	8	10.00	1.00	25.00	90.00	5.70	15.20	TD40	-
8	10	13.00	1.50	34.00	126.00	9.30	18.80	TD41	AF79
15	10	13.00	1.50	34.00	110.00	8.15	19.85	TD41	-
15	15	19.00	1.50	34.00	110.00	12.05	23.75	TD42	-
20	20	23.00	1.50	34.00	119.00	16.00	30.30	TD43	-
25	25	29.00	1.50	50.50	129.00	19.00	37.00	TD44	-
40	40	41.00	1.50	50.50	161.00	27.60	52.40	TD46	-
50	50	53.00	1.50	64.00	192.00	35.50	68.30	TD47	-
65	65	70.00	2.00	91.00	248.00	43.00	83.50	TD48	-
80	65	70.00	2.00	91.00	222.00	51.00	98.10	TD48	-
ASME BPE									
8	¼"	6.35	0.89	25.00	64.50	5.70	15.20	TG50	-
8	⅜"	9.53	0.89	25.00	89.00	5.70	15.20	TG01	AF34
8	½"	12.70	1.65	25.00	64.00	9.30	18.80	TG02	-
8	½"	12.70	1.65	25.00	89.00	9.30	18.80	TG02	AF34
15	½"	12.70	1.65	25.00	89.00	8.15	19.85	TG02	-
15	½"	12.70	1.65	25.00	108.00	8.15	19.85	TG02	AF34
15	¾"	19.05	1.65	25.00	89.00	12.05	23.75	TG03	-
20	¾"	19.05	1.65	25.00	102.00	16.00	30.30	TG03	-
20	¾"	19.05	1.65	25.00	117.00	16.00	30.30	TG03	AF34
25	1"	25.40	1.65	50.50	114.00	19.00	37.00	TG04	-
25	1"	25.40	1.65	50.50	127.00	19.00	37.00	TG04	AF34

40	1 ½"	38.10	1.65	50.50	140.00	27.60	52.40	TG05	-
40	1 ½"	38.10	1.65	50.50	159.00	27.60	52.40	TG05	AF34
50	2"	50.80	1.65	64.00	159.00	35.50	68.30	TG06	-
50	2"	50.80	1.65	64.00	190.00	35.50	68.30	TG06	AF34
65	2 ½"	63.50	1.65	77.50	249.00	43.00	83.50	TG07	-
80	2 ½"	63.50	1.65	77.50	216.00	51.00	98.10	TG07	-
80	3"	76.20	1.65	91.00	222.00	51.00	98.10	TG08	-
100 ^{2.)}	4"	101.60	2.11	119.00	306.00	63.50	127.00	TG09	-

1.) This information is part of the product key (see "7.4. Bürkert Product Enquiry Form" on page 32)

2.) Only available as block material

4.4. Tube valve body (VP) with welded connection

Note:

- Dimensions in mm, unless otherwise stated
- Further information on the draining angle, please refer to the “Additional manual Type 2xxx 3xxx” on our website (see [operating instructions Type 3323](#) ▶).

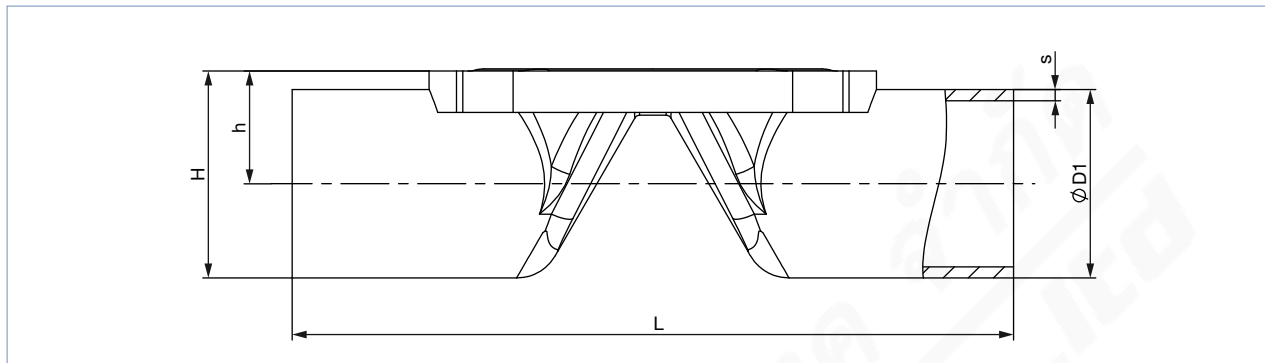

Diaphragm size	Port connection DN	ØD1	s	L	h	H	Product key ^{1.)}
DIN EN ISO 1127/ISO 4200/DIN 11866 series B							
8	8	13.50	1.60	90.00	9.45	16.20	SA40
8	10	17.20	1.60	90.00	11.30	19.90	SA41
15	15	21.30	1.60	110.00	13.95	24.60	SA42
20	20	26.90	1.60	119.00	16.75	30.20	SA43
25	25	33.70	2.00	129.00	20.15	37.00	SA44
32	32	42.40	2.00	148.00	24.70	45.90	SA45
40	40	48.30	2.00	161.00	28.95	53.10	SA46
50	50	60.30	2.00	192.00	34.95	65.10	SA47
DIN 11850 series 2/DIN 11866 series A/DIN EN 10357 series A							
8	10	13.00	1.50	90.00	9.45	16.00	SD40
15	15	19.00	1.50	110.00	12.80	22.30	SD42
15	20	23.00	1.50	119.00	14.80	26.30	SD43
20	25	29.00	1.50	129.00	17.80	32.30	SD44
25	32	35.00	1.50	148.00	20.80	38.30	SD45
32	40	41.00	1.50	161.00	24.00	44.50	SD46
40	50	53.00	1.50	192.00	31.30	57.80	SD47
ASME BPE/DIN 11866 series C							
8	½"	12.70	1.65	90.00	9.05	15.40	SA92
15	¾"	19.05	1.65	117.00	12.83	22.35	SA93
20	1"	25.40	1.65	127.00	16.00	28.70	SODF
32	1 ½"	38.10	1.65	159.00	22.55	41.60	SODH
40	2"	50.80	1.65	190.00	30.20	55.60	SODI
50	2 ½"	63.50	1.65	192.00	36.75	68.50	SODJ
65	3"	76.20	1.65	250.00	46.30	84.40	SODK
80	4"	101.60	2.11	295.00	60.00	110.80	SODL

1.) This information is part of the product key (see "7.4. Bürkert Product Enquiry Form" on page 32).

4.5. Tube valve body (VP) with clamp connection

Note:

- Dimensions in mm, unless otherwise stated
- Further information on the draining angle, please refer to the “Additional manual Type 2xxx 3xxx” on our website (see [operating instructions Type 3323](#) ▶).

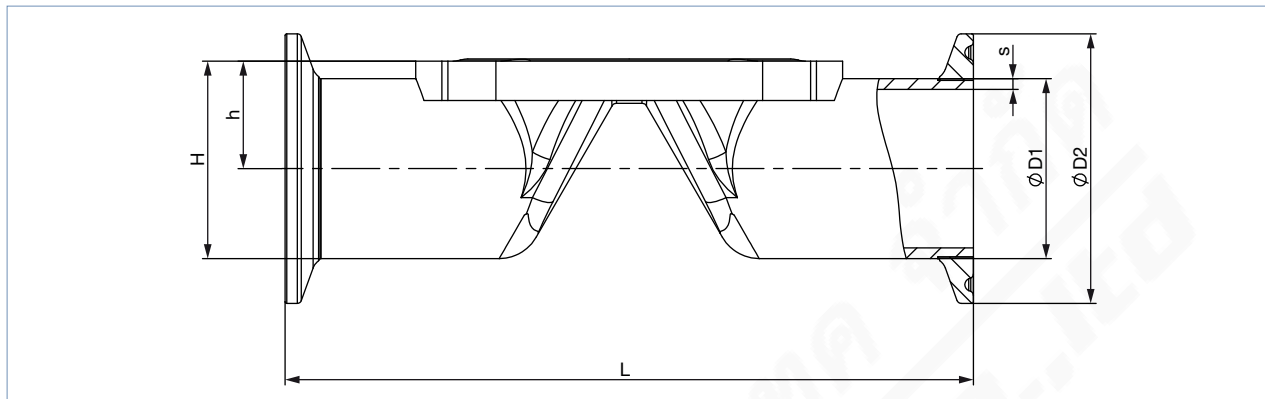

Diaphragm size	Port connection DN	ØD1	s	ØD2	L	h	H	Product key ^{1.)}
DIN 32676 series B (ISO pipe)								
8	8	13.50	1.60	25.00	89.00	9.45	16.20	TC40
8	10	17.20	1.60	25.00	89.00	11.30	19.90	TC53
15	15	21.30	1.60	50.50	110.00	13.95	24.60	TC52
20	20	26.90	1.60	50.50	119.00	16.75	30.20	TC43
25	25	33.70	2.00	50.50	129.00	20.15	37.00	TC44
32	32	42.40	2.00	64.00	148.00	24.70	45.90	TC55
40	40	48.30	2.00	64.00	161.00	28.95	53.10	TC46
50	50	60.30	2.00	77.50	192.00	34.95	65.10	TC47
DIN 32676 series A (DIN pipe)								
8	10	13.00	1.50	34.00	89.00	9.45	16.00	TD41
15	15	19.00	1.50	34.00	110.00	12.80	22.30	TD42
15	20	23.00	1.50	34.00	119.00	14.80	26.30	TD43
20	25	29.00	1.50	50.50	129.00	17.80	32.30	TD44
25	32	35.00	1.50	50.50	148.00	20.80	38.30	TD45
32	40	41.00	1.50	50.50	161.00	24.00	44.50	TD46
40	50	53.00	1.50	64.00	192.00	31.30	57.80	TD47
ASME BPE								
8	½"	12.70	1.65	25.00	89.00	9.05	15.40	TG02
15	¾"	19.05	1.65	25.00	102.00	12.83	22.35	TG03
20	1"	25.40	1.65	50.50	114.00	16.00	28.70	TG04
32	1 ½"	38.10	1.65	50.50	140.00	22.55	41.60	TG05
40	2"	50.80	1.65	64.00	159.00	30.20	55.60	TG06
50	2 ½"	63.50	1.65	77.50	190.00	36.75	68.50	TG07

1.) This information is part of the product key (see “7.4. Bürkert Product Enquiry Form” on page 32).

4.6. Tube valve body (VP) with threaded connection

Note:

- Dimensions in mm, unless otherwise stated
- Further information on the draining angle, please refer to the “Additional manual Type 2xxx 3xxx” on our website (see [operating instructions Type 3323](#) ▶).

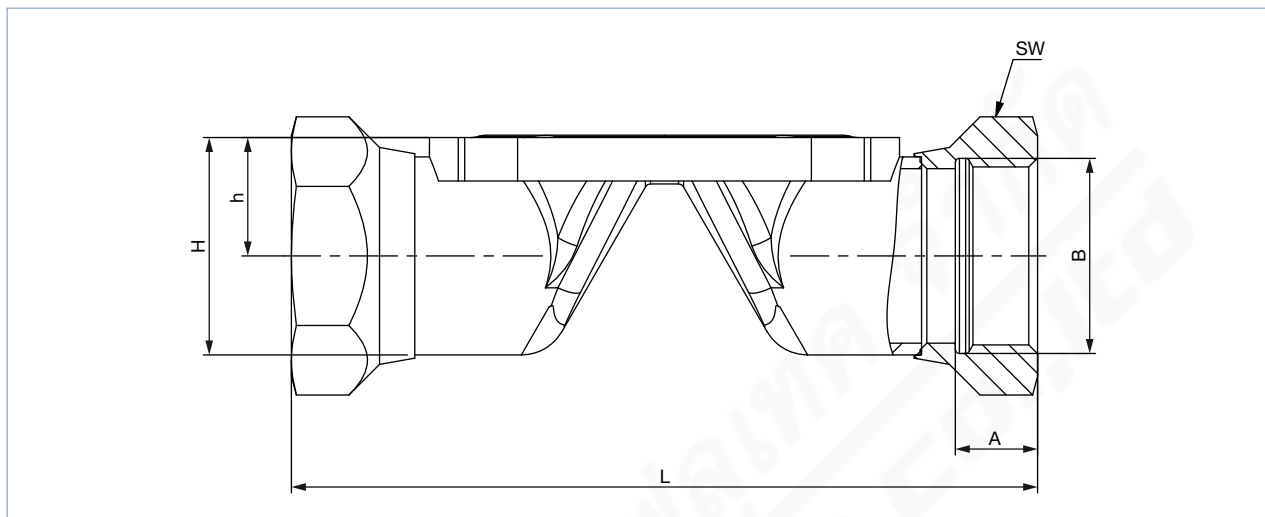

Diaphragm size	L	A	B	h	H	Spanner width of threaded ports	Product key ¹⁾
8	85.00	8.00	G ¼	9.45	16.20	17	GM82
15	102.00	14.00	G ½	13.95	24.60	27	GM84
20	118.00	12.00	G ¾	16.75	30.20	32	GM85
25	127.00	14.00	G 1	20.15	37.00	41	GM86
32	146.00	16.00	G 1 ¼	24.70	45.90	50	GM87
40	159.00	18.00	G 1 ½	28.95	53.10	60	GM88
50	191.00	20.00	G 2	34.95	65.10	70	GM89
Diaphragm size	L	A	B	h	H	Spanner width of threaded ports	Product key ¹⁾
8	58.00	9.70	Rc ¼	9.45	16.20	17	RC82
15	102.00	13.20	Rc ½	13.95	24.60	27	RC84
20	118.00	14.50	Rc ¾	16.75	30.20	32	RC85
25	127.00	16.80	Rc 1	20.15	37.00	41	RC86
32	146.00	19.10	Rc 1 ¼	24.70	45.90	50	RC87
40	159.00	19.10	Rc 1 ½	28.95	53.10	60	RC88
50	191.00	23.40	Rc 2	34.95	65.10	70	RC89
Diaphragm size	L	A	B	h	H	Spanner width of threaded ports	Product key ¹⁾
8	85.00	10.00	NPT ¼	9.45	16.20	17	NM82
15	102.00	13.70	NPT ½	13.95	24.60	27	NM84
20	118.00	14.00	NPT ¾	16.75	30.20	32	NM85
25	127.00	16.80	NPT 1	20.15	37.00	41	NM86
32	146.00	17.30	NPT 1 ¼	24.70	45.90	50	NM87
40	159.00	17.30	NPT 1 ½	28.95	53.10	60	NM88
50	191.00	17.60	NPT 2	34.95	65.10	70	NM89

1.) This information is part of the product key (see “7.4. Bürkert Product Enquiry Form” on page 32).

4.7. Tube valve body (VP) with flange connection

Note:

- Dimensions in mm, unless otherwise stated
- Further information on the draining angle, please refer to the “Additional manual Type 2xxx 3xxx” on our website (see **operating instructions Type 3323** ▶).

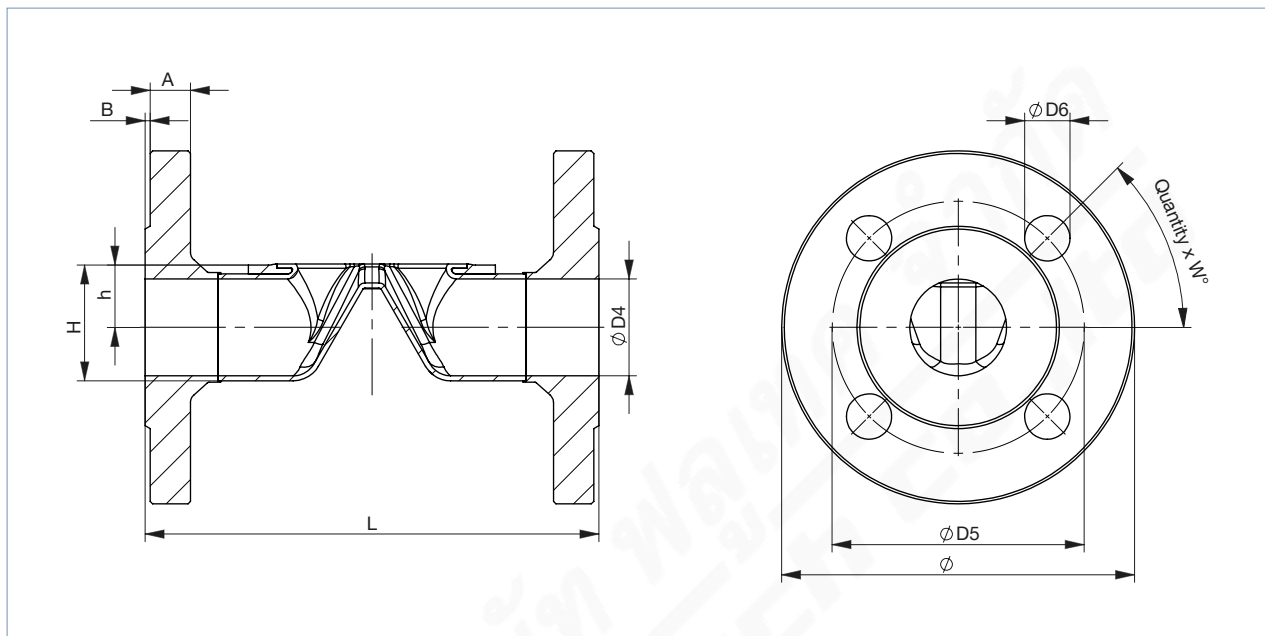

Diaphragm size	L4	L3	s3	ØD9	ØD6	ØD7	a°	ØDB	A	B	Product key ¹⁾
DIN EN 1092-1											
15	130.00	13.95	24.60	95.00	18.10	65.00	14.00	4x45°	14.00	2.00	FD22
20	150.00	16.75	30.20	105.00	23.70	75.00	14.00		16.00	2.00	FD23
25	160.00	20.15	37.00	115.00	29.70	85.00	14.00		16.00	2.00	FD24
32	180.00	24.70	45.90	140.00	38.40	100.00	18.00		16.00	2.00	FD25
40	200.00	28.95	53.10	150.00	44.30	110.00	18.00		15.00	3.00	FD26
50	230.00	34.95	65.10	165.00	56.30	125.00	18.00		17.00	3.00	FD27
ANSI B16.5											
15	130.00	12.80	22.30	89.00	15.70	60.50	15.70	4x45°	9.60	1.60	FA02
20	150.00	16.75	30.20	99.00	20.80	69.90	15.70		11.10	1.60	FA03
25	160.00	20.15	37.00	108.00	26.70	79.20	15.70		12.60	1.60	FA04
40	200.00	28.95	53.10	127.00	40.90	98.60	15.70		15.90	1.60	FA06
50	230.00	34.95	65.10	152.00	52.60	120.70	19.10		17.50	1.60	FA07
JIS 10K											
15	130.00	13.95	24.60	95.00	18.10	70.00	15.00	4x45°	11.00	1.00	FJ01
20	150.00	16.75	30.20	100.00	23.70	75.00	15.00		13.00	1.00	FJ02
25	160.00	20.15	37.00	125.00	29.70	90.00	19.00		13.00	1.00	FJ03
40	200.00	28.95	53.10	140.00	44.30	105.00	19.00		14.00	2.00	FJ05
50	230.00	34.95	65.10	155.00	56.30	120.00	19.00		14.00	2.00	FJ06

1.) This information is part of the product key (see “7.4. Bürkert Product Enquiry Form” on page 32).

DTS 1000303513 EN Version: R Status: RL (released | freigegeben | valide) printed: 19.09.2023

4.8. Cast body (VG) with welded connection

Note:

- Dimensions in mm, unless otherwise stated
- Further information on the draining angle, please refer to the “Additional manual Type 2xxx 3xxx” on our website (see [operating instructions Type 3323](#) ▶).

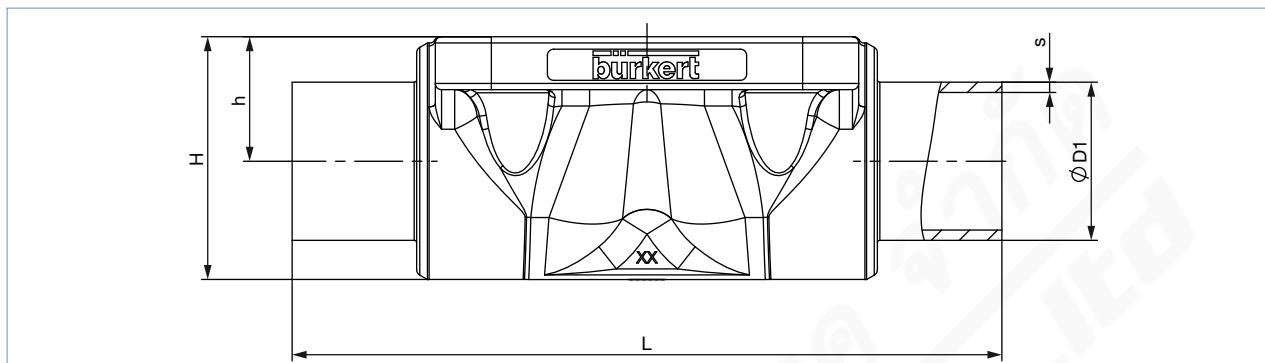

Diaphragm size	Port connection DN	ØD1	s	L	h	H	Product key ¹⁾
DIN EN ISO 1127/ISO 4200/DIN 11866 series B							
8	8	13.5	1.6	90	9.6	18.5	SA40
8	10	17.2	1.6	90	9.6	18.6	SA41
15	15	21.3	1.6	110	13.5	25.0	SA42
20	15	21.3	1.6	119	18.0	32.9	SA42
20	20	26.9	1.6	119	18.0	32.7	SA43
25	25	33.7	2.0	129	20.0	39.0	SA44
40	32	42.4	2.0	161	28.6	55.0	SA45
40	40	48.3	2.0	161	28.6	55.0	SA46
50	50	60.3	2.0	192	35.5	68.0	SA47
65	65	76.1	2.0	192	43.0	82.0	SA48
80	80	76.1	2.0	250	51.0	101.0	SA48
80	80	88.9	2.3	250	51.0	101.0	SA49
100	100	114.3	2.3	295	63.5	123.5	SA39
DIN 11850 series 2/DIN 11866 series A/DIN EN 10357 series A							
8	10	13	1.5	90	9.6	18.6	SD40
15	15	19	1.5	110	13.5	25.0	SD42
20	20	23	1.5	119	18.0	32.8	SD43
25	25	29	1.5	129	20.0	39.0	SD44
40	40	41	1.5	161	28.6	55.0	SD46
50	50	53	1.5	192	35.5	68.0	SD47
65	65	70	2.0	192	43.0	82.0	SD48
80	80	85	2.0	250	51.0	101.0	SD49
100	100	104	2.0	295	63.5	123.5	SD50
ASME BPE/DIN 11866 series C							
8	¼"	6.35	0.89	64.5	9.6	18.6	SA90
8	⅜"	9.53	0.89	89	9.6	18.6	SA91
8	½"	12.7	1.65	89	9.6	18.6	SA92
15	¾"	19.05	1.65	102	13.5	25.0	SA93
20	¾"	19.05	1.65	119	18.0	32.8	SA93
20	1"	25.4	1.65	119	18.0	32.7	SODF
25	1"	25.4	1.65	114	20.0	39.0	SODF
40	1½"	38.1	1.65	140	28.6	55.0	SODH
50	2"	50.8	1.65	159	35.5	68.0	SODI
50	2½"	63.5	1.65	192	35.5	68.0	SODJ
65	2½"	63.5	1.65	192	43.0	82.0	SODJ
80	3"	76.2	1.65	250	51.0	101.0	SODK
100	4"	101.6	2.11	295	63.5	123.5	SODL

Diaphragm size	Port connection DN	ØD1	s	L	h	H	Product key ^{1.)}
BS 4825							
8	8	6.35	1.20	64.5	9.6	18.6	SODB
8	10	9.53	1.20	89	9.6	18.6	SODC
8	15	12.7	1.20	89	9.6	18.6	SODD
15	20	19.05	1.20	102	14.0	25.5	SODE
20	25	25.4	1.65	119	18.0	32.8	SODF
25	25	25.4	1.65	114	20.0	39.0	SODF
40	40	38.1	1.65	140	28.6	55.0	SODH
50	50	50.8	1.65	159	35.5	68.0	SODI
50	65	63.5	1.65	192	35.5	68.0	SODJ
65	65	63.5	1.65	192	43.0	82.0	SODJ
80	80	76.2	1.65	250	51.0	101.0	SODK
100	100	101.6	2.11	295	63.5	123.5	SODL
SMS 3008							
20	25	25	1.2	119	18.0	32.8	SA60
25	25	25	1.2	129	20.0	39.0	SA60
40	40	38	1.2	161	28.6	55.0	SA62
50	50	51	1.2	192	35.5	68.0	SA63
DIN 11850 series 0							
8	4	6	1.0	90	9.6	18.6	SC40
8	6	8	1.0	90	9.6	18.6	SC41
8	8	10	1.0	90	9.6	18.6	SC42
15	15	18	1.5	110	13.5	25.0	SC43
20	20	22	1.5	119	18.0	32.8	SC44
25	25	28	1.5	129	20.0	39.0	SC45
25	32	34	1.5	129	20.0	39.0	SC46
40	40	40	1.5	161	28.6	56.0	SC47
50	50	52	1.5	192	35.5	68.0	SC48

1.) This information is part of the product key (see "7.4. Bürkert Product Enquiry Form" on page 32).

4.9. Cast body (VG) with clamp connection

Note:

- Dimensions in mm, unless otherwise stated
- Further information on the draining angle, please refer to the “Additional manual Type 2xxx 3xxx” on our website (see [operating instructions Type 3323](#) ▶).

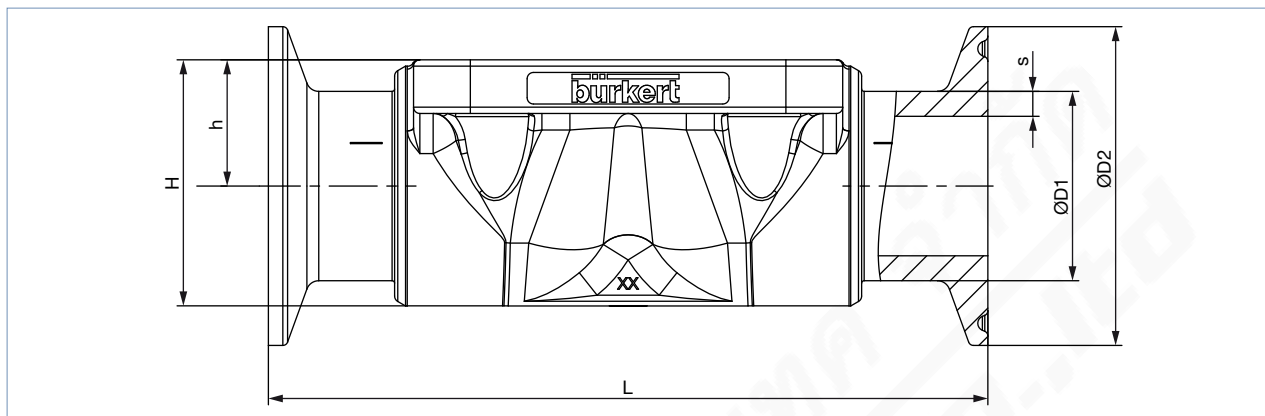

Diaphragm size	Port connection DN	ØD1	s	ØD2	L	h	H	Product key ^{1.)}
DIN 32676 series B (ISO pipe)								
25	25	33.7	2	50.5	129	20.0	39.0	TC44
40	40	48.3	2	64.0	161	28.6	55.0	TC46
50	50	60.3	2	77.5	192	35.5	68.0	TC47
DIN 32676 series A (DIN pipe)								
15	15	19	1.5	34.0	110	13.5	25.0	TD42
20	20	23	1.5	34.0	119	18.0	32.8	TD43
25	25	29	1.5	50.5	129	20.0	39.0	TD44
40	40	41	1.5	50.5	161	28.6	55.0	TD46
50	50	53	1.65	64.0	192	35.5	68.0	TD47
ASME BPE								
8	¾"	9.53	0.89	25.0	89	9.6	18.6	TG01
8	½"	12.7	1.65	25.0	89	9.6	18.6	TG02
15	¾"	19.05	1.65	25.0	102	13.5	23.0	TG03
20	¾"	19.05	1.65	25.0	117	18.0	25.0	TG03
25	1"	25.4	1.65	50.5	114	18.0	40.0	TG04
40	1½"	38.1	1.65	50.5	140	28.6	55.0	TG05
50	2"	50.8	1.65	64.0	159	35.5	68.0	TG06
50	2½"	63.5	1.65	77.5	190	35.5	68.0	TG07
65	2½"	63.5	1.65	77.5	249.2	43.0	82.0	TG07
80	3"	76.2	1.65	91	306.2	51.0	101.0	TG08
100	4"	101.6	2.11	119	352.2	63.5	123.5	TG09
BS 4825: Clamp BS 4825 -3/pipe BS 4825 - 1								
8	15	12.7	1.2	25	89	9.6	18.9	TH42
15	20	19.05	1.2	25	102	13.5	25.0	TH43
25	25	25.4	1.65	50.5	114	20.0	39.0	TG04
40	40	38.1	1.65	50.5	140	28.6	55.0	TG05
50	50	50.8	1.65	64.0	159	35.5	68.0	TG06
50	65	63.5	1.65	77.5	190	35.5	68.0	TG07
Clamp 34.0 similar to DIN 32676 series B (ISO pipe)								
15	15	21.3	1.6	34	110	13.5	25.0	TC42

1.) This information is part of the product key (see "7.4. Bürkert Product Enquiry Form" on page 32).

4.10. Plastic body (PV, PD, PP) with spigot connections

Note:

Dimensions in mm, unless otherwise stated

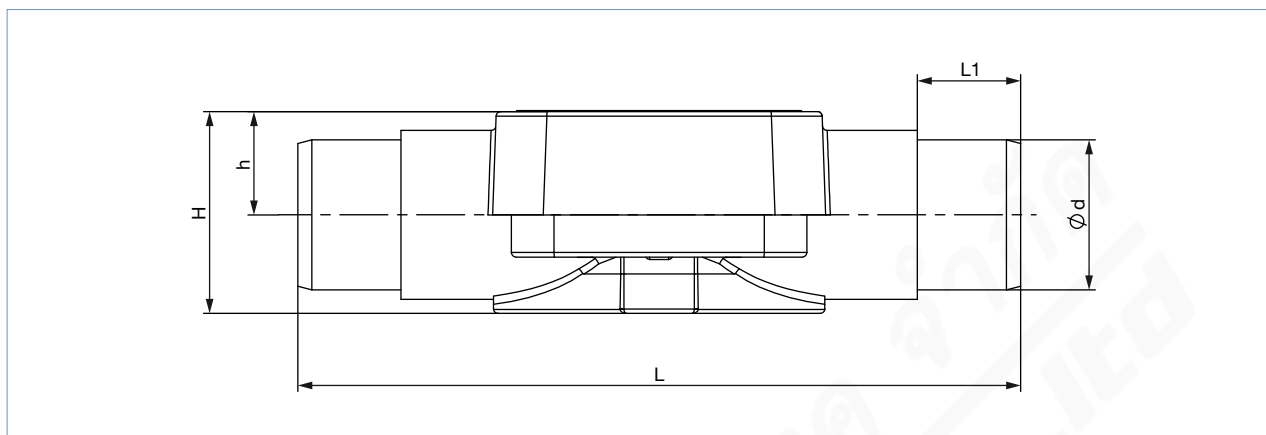

Diaphragm size	Ø d	Wall thickness	h	H	L	L1	Product key ^{1.)}
PVC-U (PV)							
15	20	2.5	15	29	124	16	KS25
20	25	2.5	18.5	36	144	19	KS26
25	32	3.5	22	43	154	22	KS27
32	40	4	27	52.5	174	26	KS28
40	50	5	33	65.5	194	31	KS29
50	63	6.5	40	79	224	44	KS30
PVDF (PD) and PP (PP)							
15	20	2.5	15	29	124	16	SS25
20	25	2.5	18.5	36	144	19	SS26
25	32	3.5	22	43	154	22	SS27
32	40	4	27	52.5	174	26	SS28
40	50	5	33	65.5	194	31	SS29
50	63	6.5	40	79	224	44	SS30

1.) This information is part of the product key (see "7.4. Bürkert Product Enquiry Form" on page 32).

DTS 1000303513 EN Version: R Status: RL (released | freigegeben | valide) printed: 19.09.2023

4.11. Plastic body (PV, PD, PP) with true union

Note:

Dimensions in mm, unless otherwise stated

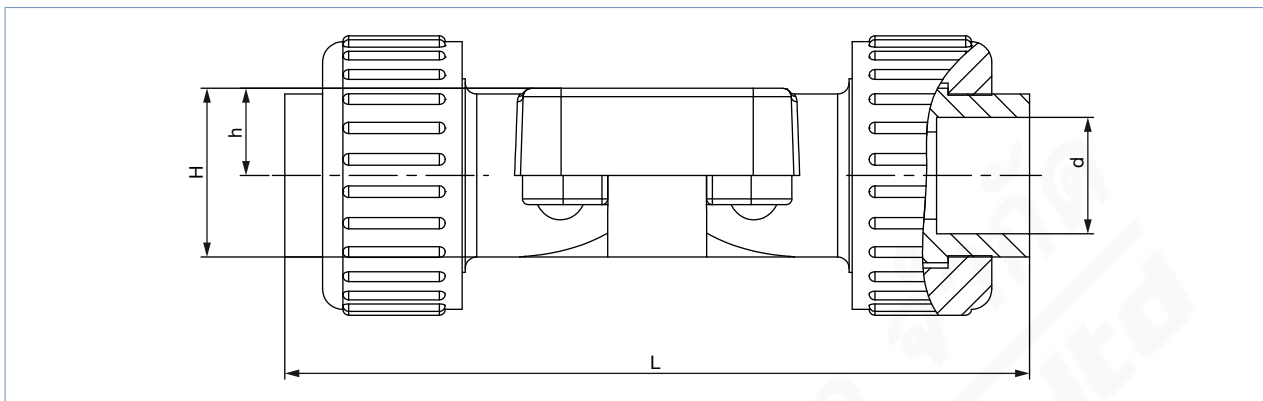

Diaphragm size	L	h	H	Ød	Product key ^{1.)}
PVC-U (PV)					
15	128	15	29	20	KM25
20	152	18.5	36	25	KM26
25	166	22	43	32	KM27
32	192	27	52.5	40	KM28
40	222	33	65.5	50	KM29
50	266	40	79	63	KM30
PVDF (PD)					
15	129	15	29	20	SM25
20	150	18.5	36	25	SM26
25	162	22	43	32	SM27
32	184	27	52.5	40	SM28
40	210	33	65.5	50	SM29
50	248	40	79	63	SM30
PP (PP)					
15	125	15	29	20	SM25
20	146	18.5	36	25	SM26
25	158	22	43	32	SM27
32	181	27	52.5	40	SM28
40	207	33	65.5	50	SM29
50	245	40	79	63	SM30

1.) This information is part of the product key (see "7.4. Bürkert Product Enquiry Form" on page 32).

4.12. Plastic body (PV, PD, PP) with flange connection

Note:

Dimensions in mm, unless otherwise stated

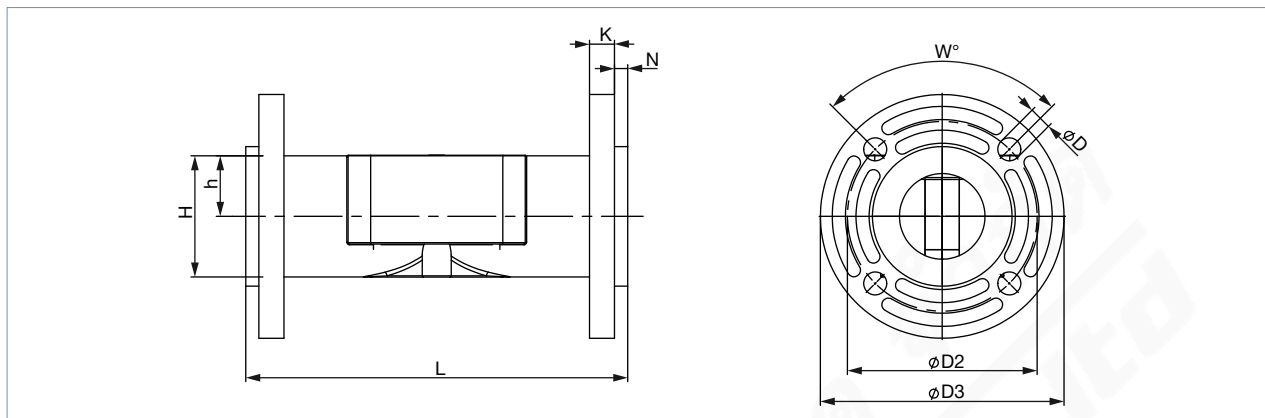

Diaphragm size	L	ØD2	ØD3	K	h	H	ØD	W	N	Product key ^{1.)}
PVC-U (PV), PVDF (PD) and PP (PP)										
15	130	65.5	96	12	15	29	14	4x90°	5.9	FL24
20	150	75	105	14	18.5	36	14	4x90°	6.9	FL25
25	160	85	115	15	22	43	14	4x90°	6.9	FL26
32	180	100	140	17	27	52.5	18	4x90°	7.9	FL27
40	200	110	150	17	33	65.5	18	4x90°	8	FL28
50	230	125	165	18	40	79	18	4x90°	9	FL29
65	290	145	185	19	47	92	18	4x90°	10	FL30
80	310	160	200	36	50	107	18	8x45°	–	FF31
100	350	180	225	35	65.5	134.5	18	8x45°	–	FF31

1.) This information is part of the product key (see "7.4. Bürkert Product Enquiry Form" on page 32).

5. Performance specifications

5.1. Fluidic Data

Flow characteristics

Note:

- The K_v values may vary slightly with different actuator sizes and diaphragm materials.
- Further K_v values on request
- Flow rate: K_v value water (m³/h) for elastomer diaphragm
- Measurement at +20 °C, 4 bar at valve inlet and 3 bar at valve outlet

Forged body (VS)

Dia- phragm size	Port connection		K_v value [m ³ /h]					
			DIN EN ISO 1127 ISO 4200 DIN 11866 series B	DIN 11850 series 2 DIN 11866 series A DIN EN 10357 series A	ASME BPE DIN 11866 series C	DIN 11850 series 0	BS4825	SMS3008
DN	[mm]	[inch]	[m ³ /h]	[m ³ /h]	[m ³ /h]	[m ³ /h]	[m ³ /h]	[m ³ /h]
8	6	1/8"	–	–	–	1.1	–	–
8	8	1/4"	1.5	–	0.7	1.7	0.5	–
8	10	3/8"	1.5	1.5	1.6	–	1.4	–
8	15	1/2"	–	–	1.5	–	–	–
15	10	3/8"	5.5	3.5	–	–	–	–
15	15	1/2"	6.5	6.5	3.1	–	3.7	–
15	20	3/4"	–	–	6.5	–	–	–
20	20	3/4"	12.5	12.4	8.4	–	8.9	–
25	25	1"	18	20	15.5	–	15.5	16
40	32	1 1/4"	–	34	–	–	–	–
40	40	1 1/2"	41	40	37	–	37	38
50	50	2"	66	66	66	–	–	–
65	65	2 1/2"	110	–	110	–	–	–
80	80	3"	160	160	160	–	–	–
100	100	4"	235	235	235	–	–	–

Tube valve body (VP)

Diaphragm size	Port connection		K_v value [m ³ /h]		
			DIN EN ISO 1127 ISO 4200 DIN 11866 series B	DIN 11850 series 2 DIN 11866 series A DIN EN 10357 series A	ASME BPE DIN 11866 series C
DN	[mm]	[inch]	[m ³ /h]	[m ³ /h]	[m ³ /h]
8	8	1/4"	1.9	–	–
8	10	3/8"	–	1.9	–
8	15	1/2"	–	–	1.8
15	10	3/8"	–	–	7.1
15	15	1/2"	7.2	7.4	–
15	20	3/4"	–	7.4	–
20	20	3/4"	13.5	–	–
20	25	1"	–	14.9	12.8
25	32	1 1/4"	–	22.3	–
25	25	1"	20.8	–	–
32	40	1 1/2"	–	34.8	31
40	40	1 1/2"	47.9	–	–
40	50	2"	–	46.2	43
50	50	2"	70	–	–
50	65	2 1/2"	–	–	52
65	80	3"	–	–	75
80	100	4"	–	–	145

Cast body (VG)

Diaphragm size DN	Port connection		K _v value
	[mm]	[inch]	[m ³ /h]
8	8	¼"	1
15	15	½"	5.6
20	20	¾"	10.7
25	25	1"	14.6
40	40	1½"	35
50	50	2"	48
65	65	2½"	110
80	80	3"	130
100	100	4"	150

Plastic body (PV, PD, PP)

Diaphragm size DN	Port connection		K _v value
	[mm]	[inch]	[m ³ /h]
15	15	½"	3
20	20	¾"	7
25	25	1"	11.4
32	32	1¼"	17
40	10	10	24.5
50	10	10	41.5
65	10	6	60
80	6	2.5 / 6	105
100	3.5	–	154

5.2. Operating limits

Medium pressure

Diaphragm size DN	Maximum operating pressure for seal material		
	EPDM, FKM	PTFE/EPDM, advanced PTFE/EPDM (EU)	GYLON®/EPDM laminated (ER)
	[bar]	[bar]	[bar]
8	10	10	10
15	10	10	10
20	10	10	10
25	10	10	10
32	8	5.5	5.5
40	10	10	10
50	10	10	10
65	10	6	6
80	6	2.5	6
100	3.5	–	–

Operating limits for ambient and medium temperature

The maximum permissible temperature for the environment and the medium are depend on each other. The maximum allowable temperature curves of different device variants can be seen in the temperature chart.

Temperature diagram AG2

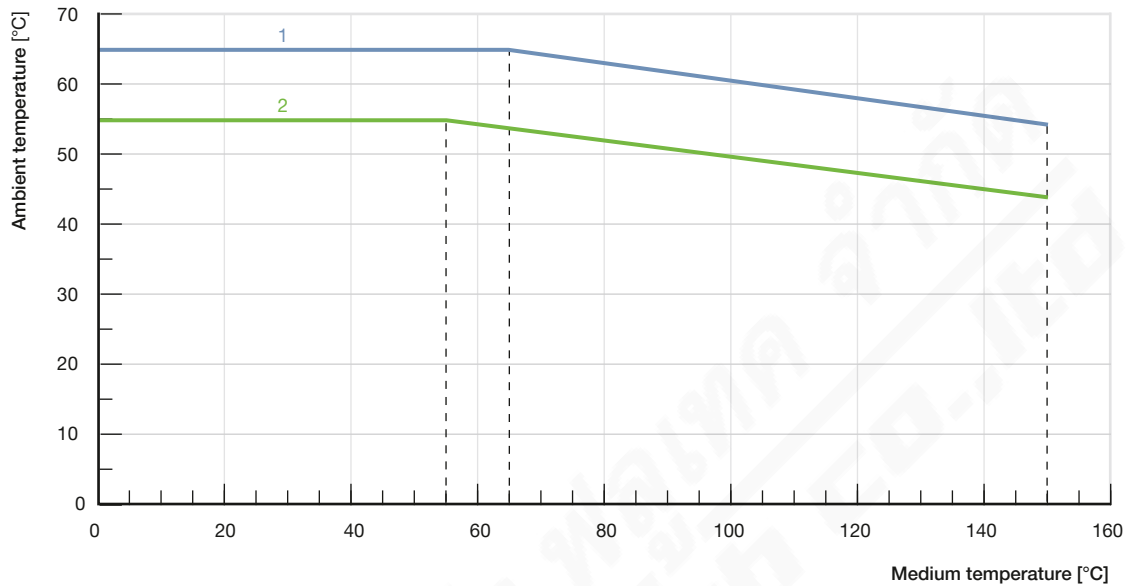

No.	Description
1	Units without module
2	Units with SAFEPOS energy-pack ^{1.)} or with fieldbus gateway

1.) The service life of the SAFEPOS energy-pack depends on the medium temperature and the ambient temperature.

Temperature diagram AG3

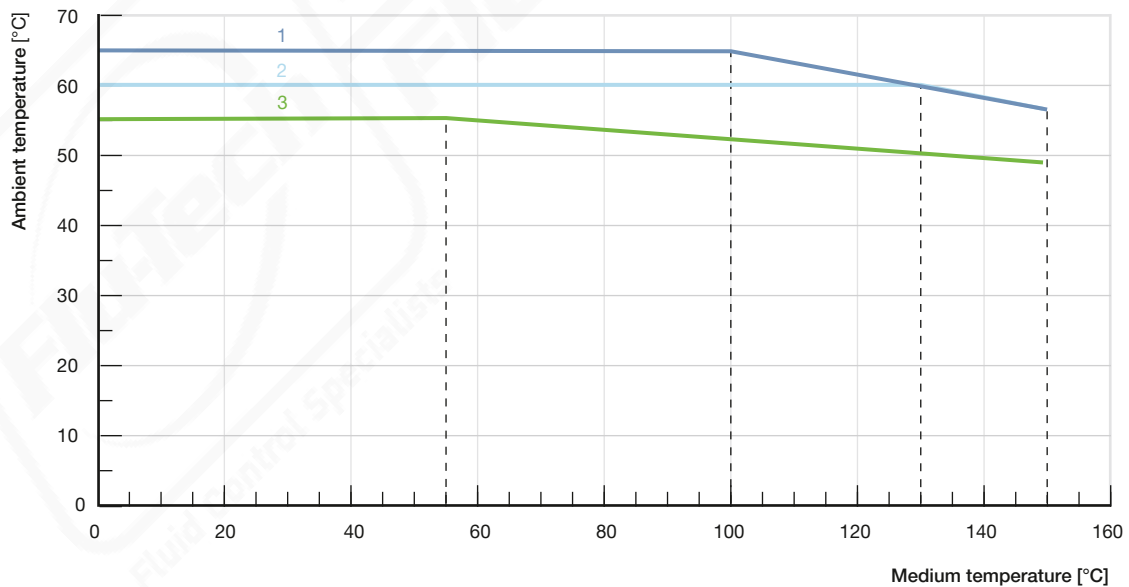

No.	Description
1	Units without module
2	Units with SAFEPOS energy-pack ^{1.)}
3	Units with fieldbus gateway

1.) The service life of the SAFEPOS energy-pack depends on the medium temperature and the ambient temperature.

Visit product website ▶

5.3. Electrical control and interfaces

Interface diagram

The position of the actuator is regulated according to the position setpoint. The position setpoint value is specified either by an external standard signal (digital) or via a field bus (digital).

Digital control

For digital control 2 variants are available for the inputs and outputs and the connection interface.

Inputs and outputs:

- 1 digital input, 2 digital outputs

Interface:

- Cable gland with connection terminal (AG2 only)
- Round connector M12 (option)

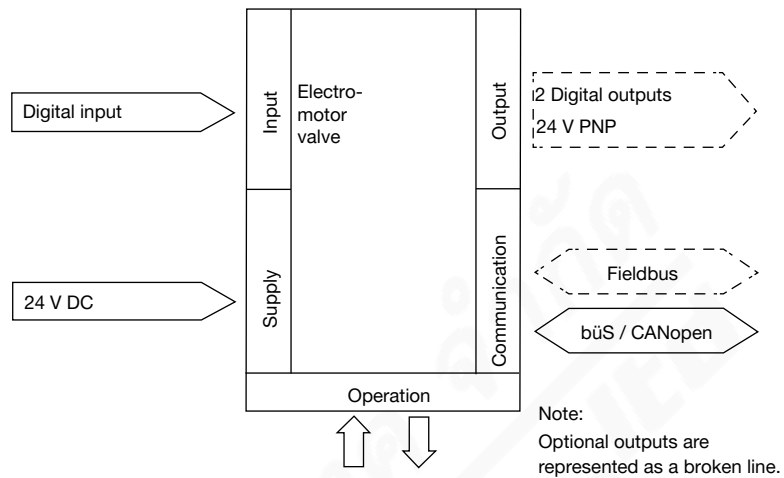

Control data	
Digital input	0...5 V = log "0", 10...30 V = log "1", inverted input reversed accordingly
Digital output (optional)	Current limitation 100 mA
Communication	
Communication interface (bûS)	Connection to PC via USB bûS interface set
Communication software (bûS)	Bürkert Communicator, see Type 8920 ▶

DTS 1000303513 EN Version: R Status: RL (released | freigegeben | validé) printed: 19.09.2023

6. Product design and assembly



6.1. Product features

Note

Further information can be found in the **operating instructions Type 3323** ►.

<p>User interface</p> <p>Devices without display module: The basic functions are operated by 4 DIP switches and 2 push buttons. These are located under the blind cover which can be removed manually by turning. Through the būs service access, the device can also be configured in detail with the Bürkert Communicator software. For this, the optional USB-būs interface kit is required.</p>	<p>Blind cover dismantled</p>
<p>Actuation</p> <p>Mechanical manual override: The manual override for mechanical movement of the valve is located under the blind cover.</p> <p>Electrical manual override: Electrical manual override for the procedure is carried out directly on the touch screen, or in the version without a display by two buttons below the dummy cover.</p>	
<p>Display elements</p> <p>Display 360° LED light ring: A clearly visible 360° LED light ring is attached to the blind cover or display module to indicate the device status, the valve end position and the operating status. The LED light ring lights up, blinks or flashes into one or changing colours, depending on the LED mode set.</p> <p>Mechanical position indicator: The mechanical position indicator shows the current valve position even if the supply voltage fails.</p>	
<p>Data transmission (optional)</p> <p>SIM card (optional): With the optionally available SIM card, device-specific values and user settings can be stored and quickly transferred to another device.</p>	
<p>būs service interface: The būs service interface connects the device with the Bürkert communicator software on a PC, laptop or smartphone. This allows to carry out a configuration of the device or an error diagnosis.</p>	

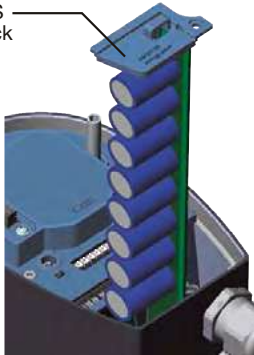
DTS 1000303513 EN Version: R Status: RL (released | freigegeben | validé) printed: 19.09.2023

Safety position via energy storage (optional)	AG2	AG3
<p>The safety starting positions in case of power interruption is realized with the optional energy storage SAFEPOS energy-pack. The desired position is set via the menu. In addition to the end positions (open/closed), any desired intermediate position can be defined here. The energy storage has a lifespan of up to 10 years, depending on the operating conditions. The power of the energy storage is monitored and a warning is displayed to indicate its life is coming to an end. The storage device is designed as a plug-in module to facilitate replacement. Without energy storage, the valve remains in the last position it was in.</p> <p>The energy storage device is fully charged and ready for operation after a maximum of 120 seconds (depending on the operating conditions). The energy storage device cannot be retrofitted in the field.</p>	 <p>SAFEPOS energy-pack</p>	
Fieldbus: EtherNet/IP, PROFINET, Modbus TCP (optional)		
<p>The fieldbus gateway for EtherNet/IP, PROFINET and Modbus TCP is integrated in an additional module. It has 2 fieldbus connections with 4-pin M12 circular sockets. The interfaces for the fieldbus connection and the status LEDs are located under the gateway housing cover. Use the web server in order to integrate EtherNet users and configure access rights.</p> <p>The gateway cannot be retrofitted in the field.</p>	 <p>Fieldbus gateway</p> <p>Fieldbus M12 connection (2 Port Ethernet Switch)</p>	

DTS 1000303513 EN Version: R Status: RL (released | freigegeben | validé) printed: 19.09.2023

6.2. Product assembly

The electromotive linear actuator consists of a brushless direct current motor, gears and a threaded spindle. The valve spindle, which is connected to the threaded spindle, transfers the force to the diaphragm. The electronic control system is actuated either via a standard signal (digital) or via a fieldbus (digital). The energy pack (SAFEPOS energy-pack) is optionally available.. If the supply voltage fails, the energy pack supplies the actuator with the required energy to move the valves into the required position which can be adjusted via a menu.

The valve position can be manually changed in 2 ways. Either via an electrical manual control or via mechanical manual control, if no supply voltage is applied. The device can be set and operated either via 2 capacitive buttons is applied 4 DIP switches. There is also the option of setting the device via the bÜS service interface and by using the PC software Bürkert-Communicator.

The intelligent process valve Type 3323 offers options for process monitoring, valve diagnostics and predictive maintenance. The state of the device is monitored and, if necessary, warnings or error messages for inadmissible environmental and operational conditions, disfunctional components or a critical state of the energy storage are displayed.

For a good diaphragm service life the actuator force is adjusted according to diaphragm size by default. For an optimum diaphragm service life, it can also be adapted to the operational conditions..

Structure, electromotive diaphragm control valve AG2



DTS 1000303513 EN Version: R Status: RL (released | freigegeben | validé) printed: 19.09.2023

Structure electromotive diaphragm control valve AG3

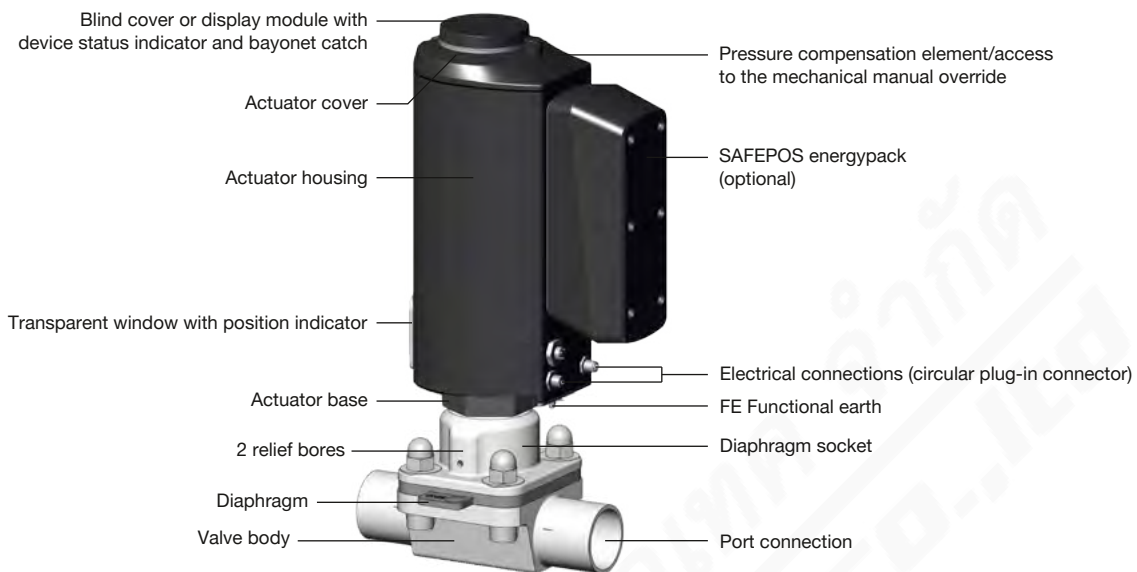

7. Ordering information

7.1. Bürkert eShop



Bürkert eShop – Easy ordering and quick delivery

You want to find your desired Bürkert product or spare part quickly and order directly? Our online shop is available for you 24/7. Sign up and enjoy all the benefits.

[Order online now](#)

7.2. Bürkert product filter



Bürkert product filter – Get quickly to the right product

You want to select products comfortably based on your technical requirements? Use the Bürkert product filter and find suitable articles for your application quickly and easily.

[Try out our product filter](#)

DTS 1000303513 EN Version: R Status: RL (released | freigegeben | validé) printed: 19.09.2023

7.3. Ordering chart accessories

Standard accessories

Description	Article no.
SIM card for data transmission between devices	291773
Holding device for port connection DN 08...40 ^{1.)}	697473
Plastic blind cover	277881
Energy storage SAFEPOS energy-pack (AG2)	285834
Energy storage SAFEPOS energy-pack (AG3)	20046438

1.) For diaphragm size 08, the holding device is included in the delivery.

Accessories cable

Note:

For connection to a bus/CANopen network see **cabling guide**

Description	Article no.
Connection cable with M12 socket, 4-pin, (length 5 m) for operating voltage (without communication)	918038
Connection cable with M12 socket, 5-pin, L coded (length 5 m) for operating voltage AG3 (without communication)	20010840
Connection cable with M12 socket, 8-pin, (length 2 m) for input and output signals	919061

Bürkert accessories

Note:

- For connection to a bus/CANopen network see **cabling guide**
- Detailed accessory tables can be found in the cabling guide.

Description	Article no.
Software Bürkert Communicator, Type 8920	LINK
büS stick set 1 (including power supply unit, bus-stick, terminating resistor, Y-distributor, 0.7 m cable with M12 connector)	772426
büS stick set 2 (including bus-stick, terminating resistor, Y-distributor, 0.7 m cable with M12 connector)	772551
büS adapter for büS interface set (M12 on büS service interface Micro-USB)	773254

7.4. Bürkert Product Enquiry Form

Note:

Please see our Product Enquiry Form for a full explanation of our specification key.

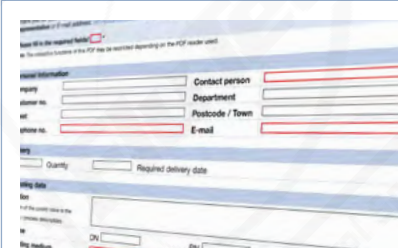

Bürkert Product Enquiry Form – Your enquiry quickly and compactly

Would you like to make a specific product enquiry based on your technical requirements? Use our Product Enquiry Form for this purpose. There you will find all the relevant information for your Bürkert contact. This will enable us to provide you with the best possible advice.

[Fill out the form now](#)