



Pneumatically operated 2-way Globe Control Valve

- Excellent control characteristics
- High cycle life and maintenance-free operation
- Flow optimised body in stainless steel
- Several Kvs value per port size due to removable valve seats
- Control units can be mounted directly without external tubing

Product variants described in the data sheet may differ from the product presentation and description.

Can be combined with

	Type 8692 ▶ Digital electro-pneumatic positioner for integrated mounting on process control valves
	Type 8694 ▶ Digital electropneumatic positioner for integrated mounting on process control valves
	Type 8696 ▶ Digital electropneumatic positioner for integrated mounting on process control valves
	Type 8693 ▶ Digital electropneumatic process controller for integrated mounting on process control valves
	Type 8792 ▶ Digital electropneumatic positioner SideControl
	Type 8791 ▶ Digital electropneumatic positioner SideControl BASIC
	Type 8793 ▶ Digital electropneumatic Process Controller SideControl

Type description

In line with Bürkert's philosophy the construction of the type 2301 globe valve fulfils tough criteria for process environments. Unrivalled cycle life and sealing integrity is guaranteed by the proven self adjusting spindle packing with exchangeable V-seals. Each globe valve body can be fitted with up to five sizes of trim sets. These parabolic trims provide a reliable and repeatable characteristic to vary the flow. The control cones are available in either stainless steel or with a durable PTFE seal or PEEK seal for tight shut-off. Leakage class III, IV or VI are available. The design enables the easy integration of automation modules whether they are digital electropneumatic positioner or process controller. The fully integrated system has a compact and smooth design, integrated pneumatic lines, IP65/67 protection class and superior chemical resistance.

DTS 1000112693 EN Version: AI Status: RL (released | freigegeben | validé) printed: 08.05.2024

FLU-TECH CO. LTD.

Email: sales@flutech.co.th **Website:** https://flutech.co.th

Tel: 02-384-6060, 086-369-5871-3 **Fax:** 02-384-5701 **LINE OA:** @flutech.co.th

Address (HQ): 845/3-4, Moo 3, Theparak Rd., T. Theparak, A. Mueang Samut Prakan, Samut Prakan, 10270, Thailand



Table of contents

1. General technical data	4
2. Product versions	5
2.1. ELEMENT	5
2.2. Stainless steel drive guide for higher drive forces	5
3. Control functions	5
4. Approvals and conformities	6
4.1. General notes	6
4.2. Conformity	6
4.3. Standards	6
4.4. Explosion protection	6
4.5. Drinking water	6
4.6. Foods and beverages/Hygiene	7
4.7. Others	7
Oxygen	7
Fuel gases	7
Hydrogen	7
5. Materials	7
5.1. Bürkert resistApp	7
5.2. Material specifications	8
ELEMENT	8
Stainless steel for higher drive forces	9
6. Dimensions	10
6.1. Actuator	10
Valve system Continuous ELEMENT	11
6.2. Body with flange connection	12
6.3. Body with threaded connection	13
6.4. Body with welded connection	14
6.5. Body with clamp connection	15
7. Performance specifications	16
7.1. Fluidic data	16
Flow characteristics	16
Overview of fluidic data for flow below seat (for liquids, steam and gases)	16
Pilot pressure diagram with flow direction below seat (control function B)	20
7.2. Operating limits	21
Operating limits for medium temperature and operating pressure	21
Operating limits for ambient and medium temperature	22
Operating limits for seat seal	22
Operating limits for optional versions	23
8. Product accessories	23
9. Networking and combination with other Bürkert products	27

10. Ordering information **29**

10.1.	Bürkert eShop	29
10.2.	Bürkert product filter	29
10.3.	Bürkert Product Enquiry Form	29
10.4.	Ordering chart flange connection	30
	Valve with flow direction below seat	30
10.5.	Ordering chart threaded connection	33
	Valve with flow direction below seat	33
10.6.	Ordering chart welded connection	36
	Valve with flow direction below seat	36
10.7.	Ordering chart clamp connection	39
	Valve with flow direction below seat	39

DTS 1000112693 EN Version: AI Status: RL (released | freigabegeben | validé) printed: 08.05.2024



1. General technical data

Product properties	
Dimensions	Further information can be found in chapter "6. Dimensions" on page 10.
Material	Further information can be found in chapter "5. Materials" on page 7.
Design	Globe control valve
Nominal diameter (port connection)	DN 10...DN 100, NPS ½...NPS 4
Safety setting in case of power failure	Normally closed (control function A), normally open (control function B)
Flow direction	Flow to open (below seat)
Performance data	
Operating pressure	0...25 bar(g), 40 bar(g) on request (see "7.1. Fluidic data" on page 16) Vacuum version...-0.9 bar(g) (option)
Nominal pressure	PN 25/PN 40 (DIN EN 1333), Class 150 (DIN EN 1759)
Seat leakage according to DIN EN 60534 - 4:2006	Leakage class III and IV for stainless steel Leakage class VI for PTFE and PEEK (see "7.1. Fluidic data" on page 16)
K _v value	0.1 m ³ /h...140 m ³ /h (see "7.1. Fluidic data" on page 16)
Operating characteristic	Equal percentage, linear (others on request)
Theoretical rangeability	...50:1
Medium data	
Medium	Steam, water, neutral gases, alcohols, oils, fuels, hydraulic fluids, salt solutions, organic solvents, oxygen and fuel gases of families I, II and III in accordance with the Gas Appliances Regulation (EU) 2016/426, Hydrogen (optional), lyes (optional)
Medium temperature	-40 °C...+230 °C (see "7.2. Operating limits" on page 21)
Viscosity	Max. 600 mm ² /s
Control medium	Air, neutral gases
Process/Port connection & communication	
Port connection ²⁾	
Flange connection	DIN EN 1092 - 1 ANSI B 16.5 JIS 10K
Threaded connection	G (DIN ISO 228 - 1) NPT (ASME B1.20.1) RC (ISO 7 - 1)
Welded connection	DIN EN ISO 1127 / ISO 4200 / DIN 11866 series B DIN 11850 - 2 / DIN 11866 series A ASME BPE / DIN 11866 series C SMS 3008
Clamp connection	DIN 32676 series B (pipe: ISO 4200) DIN 32676 series A (pipe: DIN 11850 - 2) ASME BPE
Approvals and conformities	
Further information can be found in chapter "4. Approvals and conformities" on page 6	
Environment and installation	
Ambient temperature	-10...+80 °C (with positioner or process controller Type 8791/8792/8793) -10...+55 °C (with positioner or process controller Type 8692/8693/8694) (see "7.2. Operating limits" on page 21)
Degree of protection	IP65/67
Installation position	As required, preferably with actuator upright

1.) Others are available on request.

2. Product versions

2.1. ELEMENT

Product properties	
Nominal diameter (port connection)	DN 10...DN 100
Actuator size	50 mm (D), 70 mm (M), 90 mm (N), 130 mm (P)
Performance data	
Pilot pressure (CF A)	5.6...7 bar(g) for control function B (see "Pilot pressure diagram with flow direction below seat (control function B)" on page 20)

2.2. Stainless steel drive guide for higher drive forces

Product properties	
Nominal diameter (port connection)	DN 65...DN 100
Actuator size	225 mm (L)
Performance data	
Pilot pressure (CF A)	DN 65, 3.7 bar(g)...7 bar(g) DN 80, DN 100, 5.5 bar(g)...7 bar(g) 5 bar(g) for control function B (see "Pilot pressure diagram with flow direction below seat (control function B)" on page 20)

3. Control functions

Symbol	Description
Flow direction below seat for fluids, steam and gases	
	<p>Control function A (CF A) Pneumatically operated 2/2-way control valve Flow direction below seat Normally closed by spring force</p>
	<p>Control function B (CF B) Pneumatically operated 2/2-way control valve Flow direction below seat Normally opened by spring force</p>

DTS 1000112693 EN Version: AI Status: RL (released | freigeben | validé) printed: 08.05.2024

4. Approvals and conformities

4.1. General notes

- The approvals and conformities listed below must be stated when making enquiries. This is the only way to ensure that the product complies with all required specifications.
- Not all available versions can be supplied with the below mentioned approvals or conformities.

4.2. Conformity



In accordance with the Declaration of Conformity, the product is compliant with the EU Directives. This includes the following directives:

- Pressure Equipment Directive 2014/68/EU
- Machinery Directive 2006/42/EG

4.3. Standards

The applied standards which are used to demonstrate compliance with the EU Directives are listed in the EU-Type Examination Certificate and/or the EU Declaration of Conformity.

4.4. Explosion protection

Approval	Description																
 	<p>Optional: Explosion protection As a category 2 device suitable for zone 1/21 and zone 2/22 (optional).</p> <p>ATEX: EPS 18 ATEX 2 008 X II 2G Ex h IIC T4...T2 Gb II 2D Ex h IIIC T135 °C...T300 °C Db</p> <p>IECEX: IECEX EPS 18.0007 X Ex h IIC T4...T2 Gb Ex h IIIC T135 °C...T300 °C Db</p> <table border="1"> <thead> <tr> <th>Temperature class</th> <th>T2</th> <th>T3</th> <th>T4</th> </tr> </thead> <tbody> <tr> <td>Permissible surface temperature</td> <td>+300 °C</td> <td>+200 °C</td> <td>+135 °C</td> </tr> <tr> <td>Ambient temperature Restrictions from the device</td> <td>-40...+80 °C</td> <td>-40...+80 °C</td> <td>-40...+80 °C</td> </tr> <tr> <td>Maximum medium temperature Restrictions from the device</td> <td>+230 °C</td> <td>+185 °C</td> <td>+125 °C</td> </tr> </tbody> </table>	Temperature class	T2	T3	T4	Permissible surface temperature	+300 °C	+200 °C	+135 °C	Ambient temperature Restrictions from the device	-40...+80 °C	-40...+80 °C	-40...+80 °C	Maximum medium temperature Restrictions from the device	+230 °C	+185 °C	+125 °C
Temperature class	T2	T3	T4														
Permissible surface temperature	+300 °C	+200 °C	+135 °C														
Ambient temperature Restrictions from the device	-40...+80 °C	-40...+80 °C	-40...+80 °C														
Maximum medium temperature Restrictions from the device	+230 °C	+185 °C	+125 °C														

4.5. Drinking water

Conformity	Description
	<p>Suitable for use in drinking water applications The materials comply with the assessment principles (UBA) for materials in contact with drinking water (TrinkwasserV).</p> <p>Stainless steel body PF39: Suitable for products with medium temperature up to 85 °C (hot water)</p>

4.6. Foods and beverages/Hygiene

Conformity	Description
FDA	FDA – Code of Federal Regulations (valid for the variable code PL02) All wetted materials are compliant with the Code of Federal Regulations published by the FDA (Food and Drug Administration, USA) according to the manufacturer’s declaration.
	EC Regulation 1935/2004 of the European Parliament and of the Council (valid for the variable code PL01, PL02) All wetted materials are compliant with EC Regulation 1935/2004/EC according to the manufacturer’s declaration.

4.7. Others

Oxygen

Conformity	Description
O ₂	Optional: Suitability for oxygen (valid for the variable code NL02) The products are suitable for use with gaseous oxygen, according to the manufacturer’s declaration.

Fuel gases

Conformity	Description
	Fuel gases (valid for the variable code PO19, PO20) The products comply with: <ul style="list-style-type: none"> • Regulation (EU) 2016/426 – Appliances burning gaseous fuels and • DVGW DIN EN 161 (Automatic shut-off valves for gas burners and gas appliances) and • DIN EN 16678, Class A or Class D (Safety and control devices for gas burners and gas burning appliances – Automatic shut-off valves for operating pressure of above 500 kPa up to and including 6 300 kPa)

Hydrogen

Conformity	Description
H ₂	Optional: Suitability for hydrogen (valid for the variable code NG18) The products are suitable for use with gaseous hydrogen, according to the manufacturer’s declaration.

5. Materials

5.1. Bürkert resistApp



Bürkert resistApp – Chemical resistance chart

You want to ensure the reliability and durability of the materials in your individual application case? Verify your combination of media and materials on our website or in our resistApp.

[Start chemical resistance check](#)

DTS 1000112693 EN Version: AI Status: RL (released | freigegeben | validé) printed: 08.05.2024

5.2. Material specifications

ELEMENT

Note:

The Type 2301 globe control valve is supplied with different port connections (flange, thread, welded connection and clamp). These connections are not shown. They correspond to the valve body material.

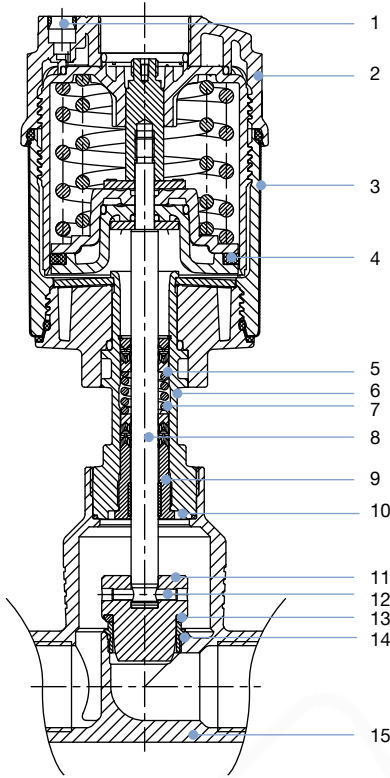

No.	Element	Material
1	Pilot air ports	Push-in connector PP
2	Actuator	PPS
3	Cover	Stainless steel 1.4561 (316Ti)
4	Piston seal	FKM
5	Spring	Stainless steel 1.4310
6	Pipe	Stainless steel CF3M
7	Spindle sealing	PTFE V-Rings (filled), with spring compensation
8	Spindle	Stainless steel 1.4401 (316)/1.4404 (316L)
9	Spindle guide	Stainless steel 1.4404 (316L), PTFE filled
10	Body seal	Graphite or PTFE
11	Control cone	Stainless steel 1.4571 (optionally hardened)
12	Spring straight pin	Stainless steel 1.4310
13	Seat seal	Stainless steel 1.4571 (optionally hardened), PTFE or PEEK
14	Valve seat with o-Ring	Stainless steel 1.4571, EPDM
15	Valve body	Stainless steel 316L / CF3M

DTS 1000112693 EN Version: AI Status: RL (released | freigegeben | validé) printed: 08.05.2024

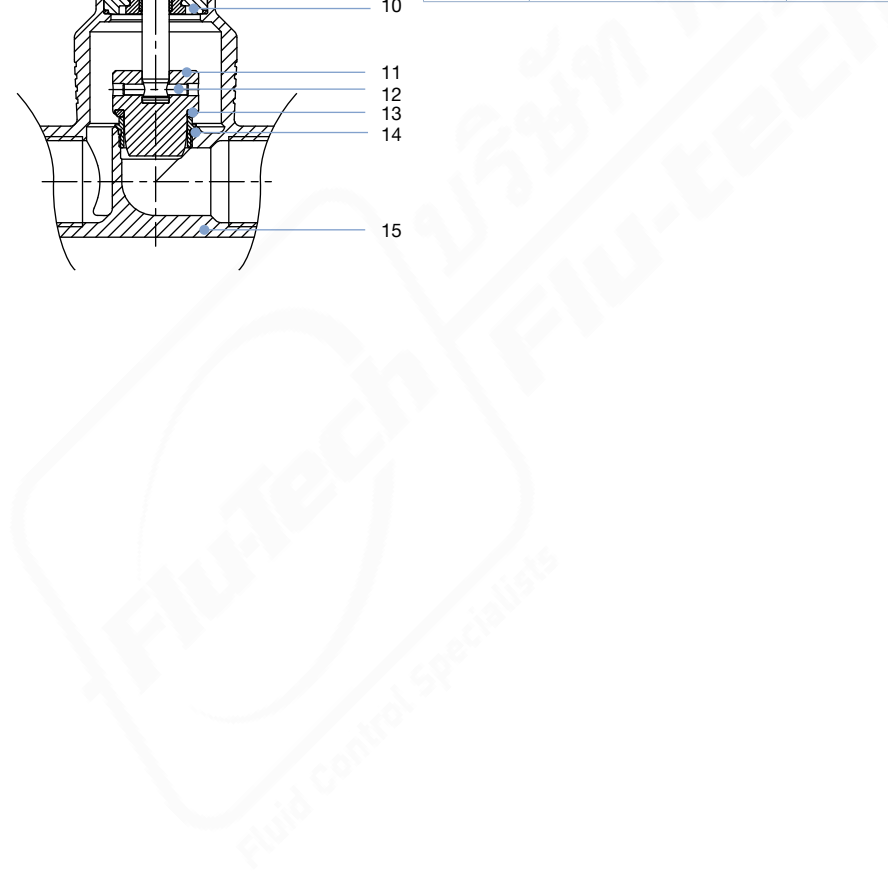

Stainless steel for higher drive forces

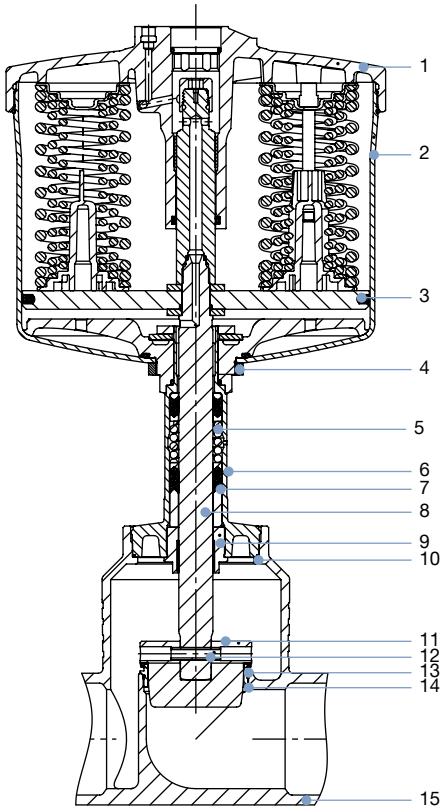

No.	Element	Material
1	Cover	Stainless steel 1.4308
2	Actuator	Stainless steel 1.4404
3	Piston seal	FKM
4	Nut	Stainless steel 1.4301
5	Spring	Stainless steel 1.4310
6	Pipe	Stainless steel CF3M
7	Spindle sealing	PTFE V-rings (filled), with spring compensation
8	Spindle	Stainless steel 1.4021
9	Spindle guide	Stainless steel 1.4404 (316L) / PTFE filled
10	Body seal	Graphite or PTFE
11	Control cone	Stainless steel 1.4571 (optionally hardened)
12	Spring straight pin	Stainless steel 1.4310
13	Seat seal	Stainless steel 1.4571 (optionally hardened), PTFE or PEEK
14	Valve seat with o-ring	Stainless steel 1.4571, EPDM
15	Valve body	Stainless steel 316L / CF3M

DTS 1000112693 EN Version: AI Status: RL (released | freigeben | validé) printed: 08.05.2024



6. Dimensions

6.1. Actuator

Note:

Dimensions in mm

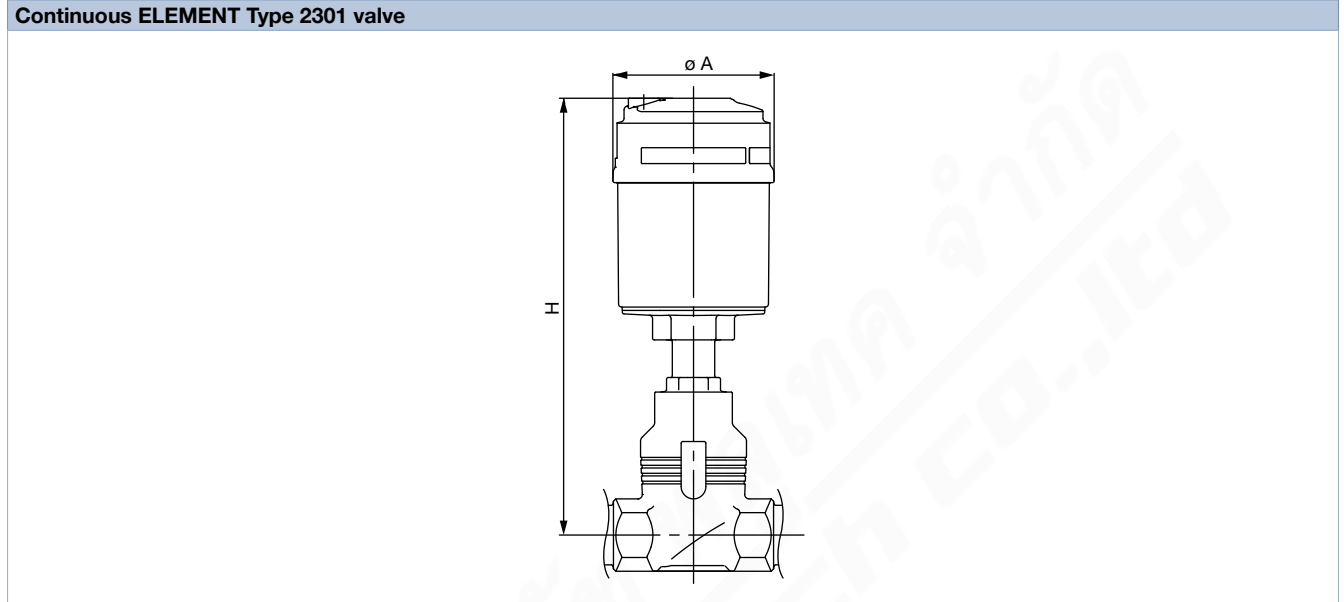

Nominal diameter (port connection)		Actuator size Ø	Ø A	H
DN	NPS			
10	3/8	50 (D)	64.5	226
		70 (M)	91	239
15	1/2	50 (D)	64.5	226
		70 (M)	91	239
20	3/4	50 (D)	64.5	232
		70 (M)	91	245
		90 (N)	120	298
25	1	50 (D)	64.5	235
		70 (M)	91	248
		90 (N)	120	301
32	1 1/4	90 (N)	120	329
		130 (P)	159	381
40	1 1/2	90 (N)	120	334
		130 (P)	159	386
50	2	90 (N)	120	340
		130 (P)	159	392
65	2 1/2	130 (P)	159	446
		225 (L)	245	460
80	3	130 (P)	159	454
		225 (L)	245	467
100	4	130 (P)	159	464
		225 (L)	245	477

DTS 1000112693 EN Version: AI Status: RL (released | freigeben | validé) printed: 08.05.2024

Valve system Continuous ELEMENT

Note:

- Dimensions in mm
- Please note actuator size A in table “6.1. Actuator” on page 10

			With positioner TopControl			With remote positioner SideControl
			Type 8692	Type 8694	Type 8696	Type 8792
			or with process controller TopControl			or with remote process controller SideControl
			Type 8693			Type 8793
Nominal diameter (port connection)		Actuator size Ø	HS with			
DN	NPS		Type 8692 or Type 8693	Type 8694 or Type 8696	Type 8792 or Type 8793	
10	3/8	50 (D)	–	329	–	
		70 (M)	383	342	342	
15	1/2	50 (D)	–	329	–	
		70 (M)	383	342	342	
20	3/4	50 (D)	–	335	–	
		70 (M)	389	348	348	
		90 (N)	442	401	401	
25	1	50 (D)	–	342	–	
		70 (M)	392	351	351	
		90 (N)	445	404	404	
32	1 1/4	90 (N)	473	432	432	
		130 (P)	525	484	484	
40	1 1/2	90 (N)	478	437	437	
		130 (P)	530	489	489	
50	2	90 (N)	484	443	443	
		130 (P)	536	495	495	
65	2 1/2	130 (P)	590	549	549	
		225 (L)	603	564	564	
80	3	130 (P)	598	557	557	
		225 (L)	611	572	572	
100	4	130 (P)	608	567	567	
		225 (L)	621	582	582	

DTS 1000112693 EN Version: AI Status: RL (released | freigeben | validé) printed: 08.05.2024

6.2. Body with flange connection

Note:
Dimensions in mm

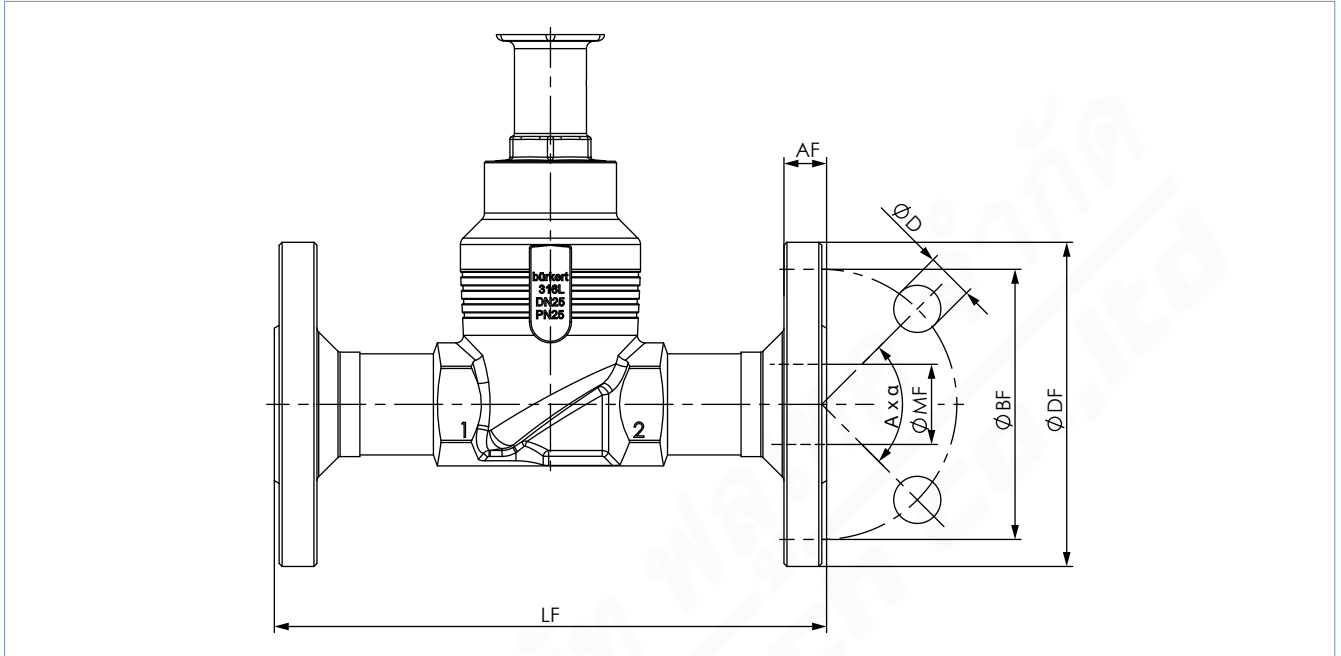

Nominal diameter (pipe)	DIN EN 1092 PN 25 FTF 1 according to DIN EN 558 - 1							JIS 10K FTF 10 according to DIN EN 558 - 2						
	DN	Ø DF	LF	Ø BF	AF	Ø D	A x α	Ø MF	Ø DF	LF	Ø BF	AF	Ø D	A x α
10	90	130	60	16	14	4 x 90°	13.6	-	-	-	-	-	-	-
15	95	130	65	16	14	4 x 90°	18.1	95	108	70	12	15	4 x 90°	18.1
20	105	150	75	18	14	4 x 90°	23.7	100	117	75	14	15	4 x 90°	23.7
25	115	160	85	18	14	4 x 90°	29.7	125	127	90	14	19	4 x 90°	29.7
32	140	180	100	18	18	4 x 90°	38.4	135	140	100	16	19	4 x 90°	38.4
40	150	200	110	18	18	4 x 90°	44.3	140	165	105	16	19	4 x 90°	44.3
50	165	230	125	20	18	4 x 90°	56.3	155	203	120	16	19	4 x 90°	56.3
65	185	290	145	22	18	8 x 45°	66.0	175	216	140	18	19	4 x 90°	71.5
80	200	310	160	24	18	8 x 45°	81.0	185	241	150	18	19	8 x 45°	84.3
100	235	350	190	24	22	8 x 45°	100.0	292	292	175	18	19	8 x 45°	109.1

Nominal diameter (pipe)	ANSI B 16.5 Class 150 FTF 37 according to DIN EN 558 - 2						
NPS	Ø DF	LF	Ø BF	AF	Ø D	A x α	Ø MF
½	89	184	60.5	11.2	15.7	4 x 90°	15.7
¾	99	184	69.9	12.7	15.7	4 x 90°	20.8
1	108	184	79.2	14.2	15.7	4 x 90°	26.7
1½	127	222	98.6	17.5	15.7	4 x 90°	40.9
2	152	254	120.7	19.1	19.1	4 x 90°	52.6
2½	178	276	139.7	22.3	19.1	4 x 90°	62.7
3	190	298	152.5	23.9	19.1	4 x 90°	78.0
4	229	352	190.5	23.9	19.1	8 x 45°	102.4

DTS 1000112693 EN Version: AI Status: RL (released | freigeben | validé) printed: 08.05.2024

6.3. Body with threaded connection

Note:
Dimensions in mm

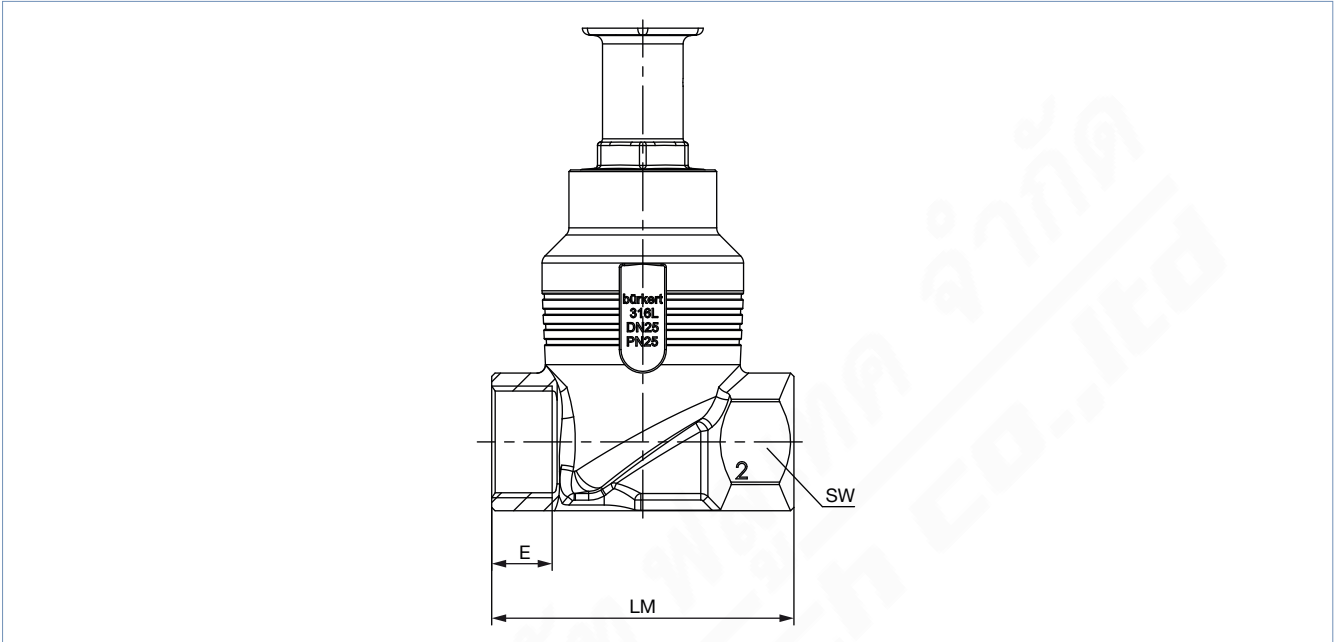

Nominal diameter (port connection)		G (DIN ISO 228 - 1) NPT (ASME B1.20.1) RC (ISO 7 - 1)			LM	SW
DN	NPS	E				
10	3/8	12	10.3	10.1	65	27
15	1/2	14	13.7	13.2	65	27
20	3/4	16	14	14.5	75	34
25	1	18	16.8	16.8	90	41
32	1 1/4	20	17.3	19.1	110	50
40	1 1/2	22	17.3	19.1	120	55
50	2	24	17.6	23.4	150	70
65	2 1/2	26	23.7	26.7	185	85
80	3	28	30.5	29.8	205	100
100	4	32	33	35.8	240	125

DTS 1000112693 EN Version: AI Status: RL (released | freigeben | validé) printed: 08.05.2024

6.4. Body with welded connection

Note:
Dimensions in mm

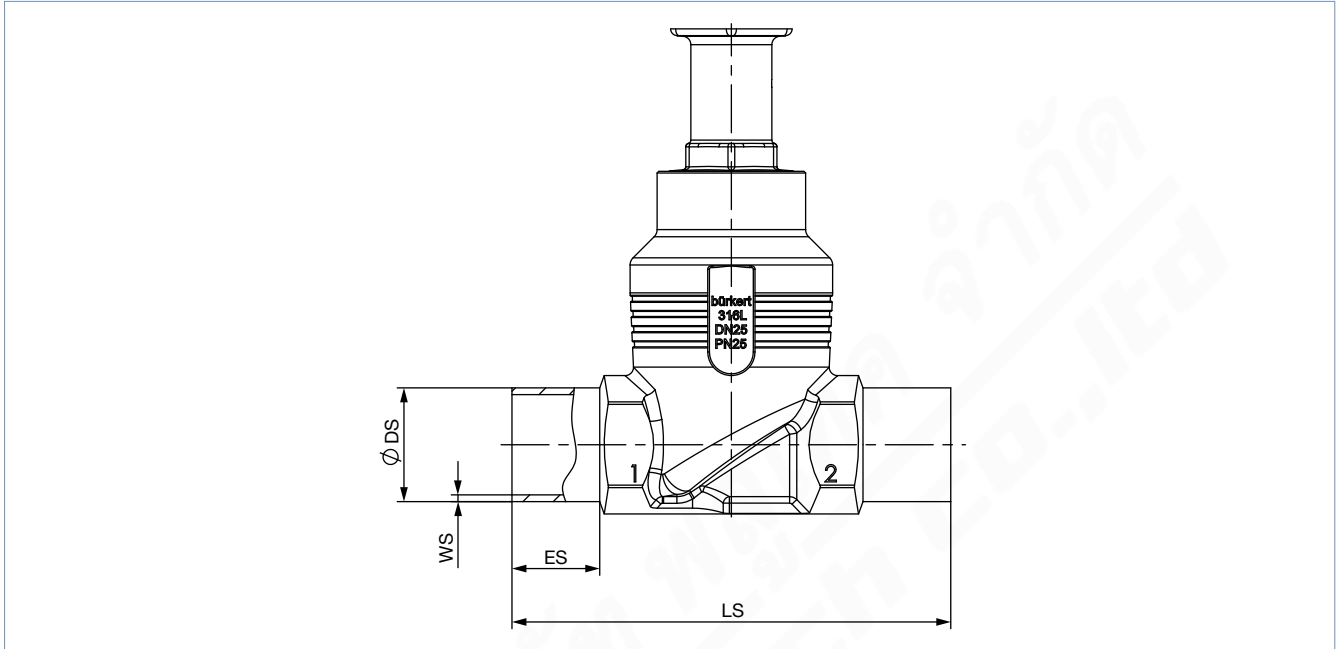

Nominal diameter (port connection) DN	ES	LS	DIN EN ISO 1127 - 1 / ISO 4200 / DIN 11866 series B		DIN 11850-2 / DIN 11866 series A / DIN EN 10357 series A	
			Ø DS	WS	Ø DS	WS
10	20	90	17.2	1.6	13	1.5
15	20	90	21.3	1.6	19	1.5
20	20	100	26.9	1.6	23	1.5
25	26	130	33.7	2.0	29	1.5
32	26	140	42.4	2.0	35	1.5
40	26	150	48.3	2.0	41	1.5
50	26	175	60.3	2.0	53	1.5
65	26	210	76.1	2.3	70	2.0
80	26	230	88.9	2.3	85	2.0
100	26	260	114.3	2.6	104	2.0

Nominal diameter (port connection) NPS	ES	LS	ASME BPE / DIN 11866 series C	
			Ø DS	WS
½	20	90	12.7	1.65
¾	20	90	19.05	1.65
1	20	100	25.4	1.65
1½	26	140	38.1	1.65
2	26	150	50.8	1.65
2½	26	175	63.5	1.65
3	26	210	76.2	1.65
4	26	260	101.6	2.11

DTS 1000112693 EN Version: AI Status: RL (released | freigeben | validé) printed: 08.05.2024

6.5. Body with clamp connection

Note:
Dimensions in mm

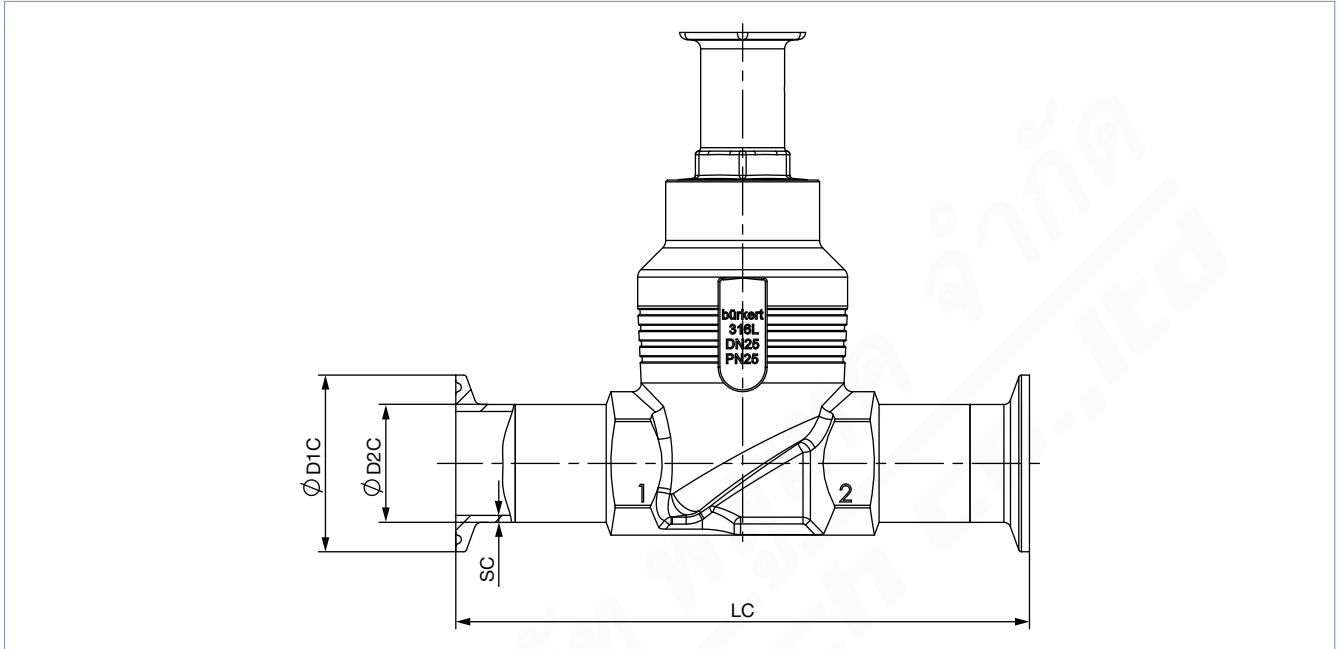

Nominal diameter (port connection)	Clamp: DIN 32676 series A Pipe: DIN 11850-2 / DIN 11866 series A / DIN EN 10357 series A				Clamp: DIN 32676 series B Pipe: DIN EN ISO 1127 / ISO 4200 / DIN 11866 series B			
	LC	Ø D2 C	Ø D1 C	SC	LC	Ø D2 C	Ø D1 C	SC
DN 15	126	19	34	1.5	146	21.3	50.5	1.6
DN 20	136	23	34	1.5	136	26.9	50.5	1.6
DN 25	173	29	50.5	1.5	164	33.7	50.5	2.0
DN 40	193	41	50.5	1.5	193	48.3	64.0	2.0
DN 50	218	53	64	1.5	218	60.3	77.5	2.0

Nominal diameter (port connection)	Clamp: ASME BPE / DIN 11866 series C Pipe: ASME BPE / DIN 11866 series C			
NPS	LC	Ø D2 C	Ø D1 C	SC
½	122	12.7	25.0	1.65
¾	126	19.05	25.0	1.65
1	126	25.4	50.5	1.65
1½	172	38.1	50.5	1.65
2	182	50.8	64.0	1.65
2½	231	63.5	77.5	1.65
3	265	76.2	91.0	1.65
4	315	101.6	119.0	2.11

DTS 1000112693 EN Version: AI Status: RL (released | freigeben | validé) printed: 08.05.2024

7. Performance specifications

7.1. Fluidic data

Flow characteristics

- Equal-percentage flow characteristic according to DIN EN 60534-2-4 (linear characteristic curve on request)
- K_{VR} value at 5 % of the stroke for seat size > 10 mm
 K_{VR} value at 10 % of the stroke for seat size ≤ 10 mm
- Actuator size 70 offers a better control quality compared to actuator size 50 and is therefore preferred (K_{VR} value = smallest K_V value, at which the tilt tolerance according to DIN EN 60534-2-4 is still maintained).

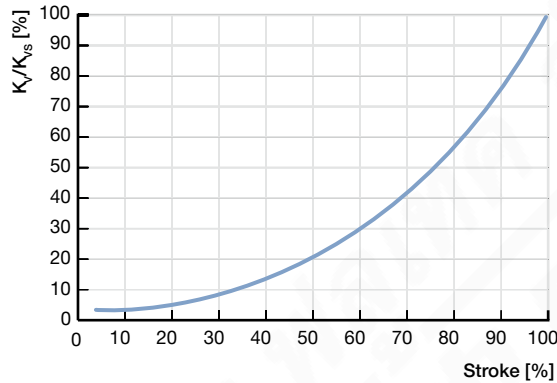

Equal percentage flow curve - detailed values please see below

Overview of fluidic data for flow below seat (for liquids, steam and gases)

Note:

- K_V value [m³/h]: measurement with water according to DIN EN 60534-2-4
- Operating limits (see "7.2. Operating limits" on page 21)

Nominal diameter (port connection)		Seat size	Actuator size Ø	Operating pressure max. (Seat leakage class)			Theoretical rangeability	K_V value water at stroke [m ³ /h]										K_{VS} value
				Seat seal				5%	10%	20%	30%	40%	50%	60%	70%	80%	90%	
				CF A	Stainless steel	PTFE	PEEK											
DN	NPS		[mm]	[bar(g)]				[m ³ /h]										
10	3/8 ⁽²⁾	3	50 (D)	16 (IV)	-	-	10:1	-	0.005	0.009	0.013	0.019	0.026	0.034	0.044	0.060	0.077	0.1
			70 (M)	25 (IV) 40 (IV) ⁽⁴⁾														
		3	50 (D)	16 (IV)	-	-	20:1	-	0.009	0.015	0.023	0.033	0.046	0.063	0.085	0.11	0.16	0.2
			70 (M)	25 (IV) 40 (IV) ⁽⁴⁾														
		4	50 (D)	16 (IV)	-	-	30:1	-	0.023	0.033	0.049	0.070	0.097	0.14	0.18	0.26	0.35	0.5
			70 (M)	25 (IV) 40 (IV) ⁽⁴⁾														
		6	50 (D)	16 (IV)	16 (VI)	10 (VI)	50:1	0.005	0.007	0.011	0.045	0.085	0.16	0.26	0.41	0.65	1.1	1.25
			70 (M)	25 (IV) 40 (IV) ⁽⁴⁾	25 (IV) 40 (IV) ⁽⁴⁾	25 (VI)												
		8	50 (D)	16 (IV)	16 (VI)	10 (VI)	0.060	0.070	0.090	0.12	0.18	0.26	0.42	0.61	0.92	1.5	2.0	
			70 (M)	25 (IV) 40 (IV) ⁽⁴⁾	25 (IV) 40 (IV) ⁽⁴⁾	25 (VI)												
		10	50 (D)	16 (IV)	16 (VI)	10 (VI)	0.090	0.11	0.13	0.19	0.30	0.48	0.73	1.0	1.6	2.3	2.7	
			70 (M)	25 (IV) 40 (IV) ⁽⁴⁾	25 (IV) 40 (IV) ⁽⁴⁾	25 (VI)												

DTS 1000112693 EN Version: AI Status: RL (released | freigegeben | validé) printed: 08.05.2024

Nominal diameter (port connection)		Seat size	Actuator size Ø	Operating pressure max. (Seat leakage class)			Theoretical range-ability	K _v value water at stroke [m³/h]										K _{vs} value		
				Seat seal				5%	10%	20%	30%	40%	50%	60%	70%	80%	90%		100%	
DN	NPS	[mm]	[bar(g)]			[m³/h]														
				CF A	Stainless steel	PTFE	PEEK													
15	½ ^{2,3)}	3	50 (D)	16 (IV)	-	-	10:1	-	0.005	0.009	0.013	0.019	0.026	0.034	0.044	0.060	0.077	0.1		
			70 (M)	25 (IV) 40 (IV) ^{4,3)}				-	-	-	-	-	-	-	-	-	-	-	-	-
		3	50 (D)	16 (IV)	50:1	0.005		0.007	0.011	0.045	0.085	0.16	0.26	0.41	0.65	1.1	1.25			
			70 (M)	25 (IV) 40 (IV) ^{4,3)}		16 (VI)		25 (VI) 40 (VI) ^{4,3)}	25 (VI)	25 (VI)	0.070	0.080	0.11	0.13	0.19	0.27	0.43	0.63	0.95	1.6
		4	50 (D)	16 (IV)		16 (VI)		10 (VI)	0.090	0.11	0.15	0.19	0.31	0.49	0.75	1.1	1.7	2.5	3.1	
			70 (M)	25 (IV) 40 (IV) ^{4,3)}		25 (VI) 40 (VI) ^{4,3)}		25 (VI)	25 (VI)	0.14	0.17	0.22	0.35	0.52	0.80	1.2	1.8	2.7	3.7	4.3
		6	50 (D)	16 (IV)		16 (VI)		10 (VI)	0.11	0.12	0.16	0.20	0.33	0.52	0.77	1.2	1.8	2.6	3.2	
			70 (M)	25 (IV) 40 (IV) ^{4,3)}		25 (VI) 40 (VI) ^{4,3)}		25 (VI)	25 (VI)	0.14	0.17	0.22	0.35	0.52	0.80	1.2	1.8	2.9	4.0	5.2
		8	50 (D)	16 (IV)		16 (VI)		10 (VI)	0.20	0.25	0.30	0.45	0.70	1.1	1.6	2.4	3.5	5.2	7.1	
			70 (M)	25 (IV) 40 (IV) ^{4,3)}		25 (VI) 40 (VI) ^{4,3)}		25 (VI)	25 (VI)											
		10	50 (D)	16 (IV)		16 (VI)		10 (VI)												
			70 (M)	25 (IV) 40 (IV) ^{4,3)}		25 (VI) 40 (VI) ^{4,3)}		25 (VI)	25 (VI)											
15	50 (D)	16 (IV)	16 (VI)	10 (VI)																
	70 (M)	25 (IV) 40 (IV) ^{4,3)}	25 (VI) 40 (VI) ^{4,3)}	25 (IV)		25 (IV)														

DTS 1000112693 EN Version: AI Status: RL (released | freigeben | validé) printed: 08.05.2024

Nominal diameter (port connection)		Seat size	Actuator size Ø	Operating pressure max. (Seat leakage class)			Theoretical range-ability	K _v value water at stroke [m³/h]											K _{vs} value									
				Seat seal				5%	10%	20%	30%	40%	50%	60%	70%	80%	90%	100%										
DN	NPS	[mm]	[bar(g)]			[m³/h]																						
				CF A	Stainless steel	PTFE	PEEK																					
25	1	3	50 (D)	16 (IV)	-	-	10:1	-	0.005	0.009	0.013	0.019	0.026	0.034	0.044	0.060	0.077	0.1										
			70 (M)	25 (IV) 40 (IV) ^{4,3}																								
		3	50 (D)	16 (IV)	50:1	-		0.009	0.015	0.023	0.033	0.046	0.063	0.085	0.11	0.16	0.2											
			70 (M)	25 (IV) 40 (IV) ^{4,3}																								
		4	50 (D)	16 (IV)		-		0.023	0.033	0.049	0.070	0.097	0.14	0.18	0.26	0.35	0.5											
			70 (M)	25 (IV) 40 (IV) ^{4,3}																								
		6	50 (D)	16 (IV)		16 (VI)		10 (VI)	0.005	0.007	0.011	0.045	0.085	0.16	0.26	0.41	0.65	1.1	1.25									
			70 (M)	25 (IV) 40 (IV) ^{4,3}		25 (VI) 40 (VI) ^{4,3}		25 (VI)																				
		8	50 (D)	16 (IV)		16 (VI)		10 (VI)	0.070	0.080	0.11	0.13	0.19	0.27	0.43	0.63	0.95	1.6	2.1									
			70 (M)	25 (IV) 40 (IV) ^{4,3}		25 (VI) 40 (VI) ^{4,3}		25 (VI)																				
		10	50 (D)	16 (IV)		16 (VI)		10 (VI)	0.11	0.12	0.16	0.20	0.33	0.52	0.77	1.2	1.8	2.6	3.2									
			70 (M)	25 (IV) 40 (IV) ^{4,3}		25 (VI) 40 (VI) ^{4,3}		25 (VI)																				
15	50 (D)	16 (IV)	16 (VI)	10 (VI)		0.14	0.17	0.22	0.35	0.52	0.80	1.2	1.8	2.9	4.1	5.3												
	70 (M)	25 (IV) 40 (IV) ^{4,3}	25 (VI) 40 (VI) ^{4,3}	25 (VI)																								
20	70 (M)	16 (IV)	16 (VI)	10 (VI)	0.20	0.25	0.31	0.47	0.70	1.1	1.6	2.5	3.8	5.4	7.2													
	90 (N)	25 (IV) 40 (IV) ^{4,3}	25 (VI) 40 (VI) ^{4,3}	25 (VI)																								
25	70 (M)	12 (IV)	12 (VI)	7 (VI)	0.35	0.38	0.65	1.0	1.5	2.2	3.4	5.1	7.0	9.4	12.0													
	90 (N)	25 (IV)	25 (VI)	20 (VI)																								
32	1¼ ^{2,3}	20	90 (N)	25 (IV)	25 (VI)	25 (VI)	0.21	0.24	0.32	0.43	0.60	0.85	1.2	1.6	2.3	3.3	4.8											
			130 (P)															25 (VI)										
		25	90 (N)		20 (VI)																							
			130 (P)		25 (VI)																							
		32	90 (N)	16 (IV)	16 (VI)	10 (VI)												0.45	0.58	0.80	1.1	1.7	2.5	3.5	4.9	7.0	10.1	13.4
			130 (P)	25 (IV)	25 (VI)	20 (VI)																						
40	1½ ^{2,3}	25	90 (N)	25 (IV)	25 (VI)	10 (VI)	0.38	0.47	0.68	0.95	1.4	1.9	2.7	3.7	5.2	7.2	9.4											
			130 (P)															25 (VI)										
32	90 (N)	16 (IV)	16 (VI)	10 (VI)	0.45	0.55	0.80	1.1	1.7	2.5	3.6	5.0	7.2	10.8	14.4													
		130 (P)	25 (IV)	25 (VI)												20 (VI)												
40	90 (N)	12 (IV)	12 (VI)	7 (VI)	0.48	0.60	0.85	1.3	2.1	3.2	4.6	6.9	11.0	15.0	20.0													
		130 (P)	25 (IV)	25 (VI)												20 (VI)												
40	90 (N)	12 (IV)	12 (VI)	7 (VI)	0.55	0.67	1.0	1.5	2.3	3.2	4.5	6.5	9.5	13.7	17.5													
		130 (P)	25 (IV)	25 (VI)												20 (VI)												
40	90 (N)	12 (IV)	12 (VI)	7 (VI)	0.60	0.70	1.1	1.7	2.7	4.0	6.0	9.2	13.8	18.2	24.0													
		130 (P)	25 (IV)	25 (VI)												20 (VI)												

DTS 1000112693 EN Version: AI Status: RL (released | valide) | freigegeben | printed: 08.05.2024

DTS 1000112693 EN Version: AI Status: RL (released | freigegeben | validé) printed: 08.05.2024

Nominal diameter (port connection)		Seat size	Actuator size Ø	Operating pressure max. (Seat leakage class)			Theoretical range-ability	K _v value water at stroke [m³/h]											K _{vs} value	
				Seat seal				5%	10%	20%	30%	40%	50%	60%	70%	80%	90%	100%		
				CF A	Stainless steel	PTFE														PEEK
DN	NPS	[mm]	[bar(g)]				[m³/h]													
50	2 ²⁾	20	90 (N)	25 (20 ¹⁾) (IV)	-	-	50:1	-	0.12	0.23	0.33	0.47	0.67	0.96	1.4	1.9	2.7	3.8		
				130 (P)				25 (20 ¹⁾) (IV)	0.14	0.25	0.38	0.57	0.85	1.3	1.9	2.8	4.1	6.3		
			32	90 (N)	16 (IV)	0.29		0.46	0.66	0.95	1.3	1.9	2.7	3.7	5.2	7.4				
				130 (P)	25 (20 ¹⁾) (IV)	0.31		0.51	0.76	1.1	1.7	2.5	3.6	5.3	7.9	12.0				
			32	90 (N)	16 (IV)	16 (VI)		10 (VI)	0.45	0.56	0.80	1.1	1.7	2.5	3.6	5.0	7.2	11.4	15.3	
				130 (P)	25 (20 ¹⁾) (IV)	25 (20 ¹⁾) (VI)		20 (VI)	0.48	0.60	0.90	1.3	2.1	3.2	4.6	6.9	11.6	16.0	21.0	
		40	90 (N)	12 (IV)	12 (VI)	7 (VI)		0.57	0.68	0.90	1.5	2.1	3.2	4.5	6.4	9.5	13.8	18.0		
			130 (P)	25 (20 ¹⁾) (IV)	25 (20 ¹⁾) (VI)	20 (VI)		0.60	0.70	1.0	1.7	2.6	4.0	5.9	9.2	14.0	18.9	24.5		
		50	90 (N)	7 (III)	7 (VI)	-		0.85	1.1	1.7	2.6	3.8	5.4	7.7	11.4	16.0	21.5	28.0		
			130 (P)	25 (20 ¹⁾) (IV)	25 (20 ¹⁾) (VI)	20 (VI)		0.90	1.1	1.9	2.9	4.5	6.8	10.5	15.5	22.0	29.5	37.0		
		65	2 ½ ²⁾	40	130 (P)	25 (15 ¹⁾) (IV)		25 (15 ¹⁾) (VI)	20 (15 ¹⁾) (VI)	0.65	0.75	1.1	1.8	2.8	4.3	6.5	10.4	16.0	22.0	29.0
					50	130 (P)		16 (15 ¹⁾) (IV)	16 (15 ¹⁾) (VI)	10 (VI)	1.0	1.2	2.0	3.1	4.8	6.7	9.7	16.0	24.0	35.0
				65	130 (P)	16 (15 ¹⁾) (IV)		16 (15 ¹⁾) (VI)	10 (VI)	1.6	2.0	3.0	5.0	8.0	13.5	22.0	33.0	45.0	56	65
					225 (L) ³⁾	20 (15 ¹⁾) (IV)		20 (15 ¹⁾) (VI)	12 (VI)	1.1	1.4	2.1	3.2	4.9	8.0	12.0	18.5	31.5	46.5	62
225 (L)	25 (15 ¹⁾) (IV)			25 (15 ¹⁾) (VI)	25 (15 ¹⁾) (VI)	1.0	1.2	2.0	3.4	5.3	8.3	13.0	19.0	26.0	35.0	45.0				
80	130 (P)			25 (12.5 ¹⁾) (IV)	25 (12.5 ¹⁾) (VI)	20 (12.5 ¹⁾) (VI)	1.6	2.0	2.9	5.0	8.2	13.0	22.0	35.0	48.0	61	73			
80	3 ²⁾	50	130 (P)	25 (12.5 ¹⁾) (IV)	25 (12.5 ¹⁾) (VI)	20 (12.5 ¹⁾) (VI)	1.0	1.2	2.0	3.4	5.3	8.3	13.0	19.0	26.0	35.0	45.0			
			65	130 (P)	16 (12.5 ¹⁾) (IV)	16 (12.5 ¹⁾) (VI)	10 (VI)	1.6	2.0	2.9	5.0	8.2	13.0	22.0	35.0	48.0	61	73		
		225 (L) ³⁾	25 (12.5 ¹⁾) (IV)	25 (12.5 ¹⁾) (VI)	16 (12.5 ¹⁾) (VI)	1.4	1.7	2.5	3.8	5.7	8.2	12.2	19.5	32.5	50	70				
			225 (L)	25 (12.5 ¹⁾) (IV)	25 (12.5 ¹⁾) (VI)	22.5 (12.5 ¹⁾) (VI)	2.5	3.4	6.3	10.7	16.0	27.0	42.5	58	73	87	100			
		80	130 (P)	10 (IV)	10 (VI)	10 (VI)	2.1	2.6	4.2	7.0	10.5	16.0	25.0	40.0	60	83	100			
			225 (L) ³⁾	16 (12.5 ¹⁾) (IV)	16 (12.5 ¹⁾) (VI)	10 (VI)	1.4	1.7	2.5	3.8	5.7	8.2	12.2	19.5	32.5	50	70			
100	4	65	130 (P)	16 (10 ¹⁾) (IV)	16 (10 ¹⁾) (VI)	10 (VI)	1.4	1.8	2.8	5.0	8.8	15.0	25.0	37.0	50	64	77			
			225 (L) ³⁾	25 (10 ¹⁾) (IV)	25 (10 ¹⁾) (VI)	16 (10 ¹⁾) (VI)	1.4	1.7	2.6	3.8	5.7	8.3	12.6	20.0	32.0	51	75			
			225 (L)	25 (10 ¹⁾) (IV)	25 (10 ¹⁾) (VI)	20 (10 ¹⁾) (VI)	2.2	3.1	5.9	10.3	17.5	30.0	48.0	66	82	97	110			
		80	130 (P)	10 (IV)	10 (VI)	10 (VI)	2.1	2.6	4.3	7.0	11.0	17.0	26.5	44.0	65	89	115			
			225 (L) ³⁾	16 (10 ¹⁾) (IV)	16 (10 ¹⁾) (VI)	10 (VI)	2.2	3.1	5.9	10.3	17.5	30.0	48.0	66	82	97	110			
		225 (L)	25 (10 ¹⁾) (IV)	25 (10 ¹⁾) (VI)	15 (10 ¹⁾) (VI)	3.8	5.2	9.5	15.0	26.0	46.5	68	90	111	128	140				
			225 (L)	16 (10 ¹⁾) (IV)	16 (10 ¹⁾) (VI)	10 (VI)	3.2	3.9	5.7	9.0	13.5	20.5	32.0	51	83	118	140			
		100	130 (P)	6 (IV)	6 (VI)	-	3.8	5.2	9.5	15.0	26.0	46.5	68	90	111	128	140			
			225 (L) ³⁾	10 (IV)	10 (VI)	6 (VI)	3.2	3.9	5.7	9.0	13.5	20.5	32.0	51	83	118	140			
		225 (L)	16 (10 ¹⁾) (IV)	16 (10 ¹⁾) (VI)	10 (VI)	3.2	3.9	5.7	9.0	13.5	20.5	32.0	51	83	118	140				

1.) According to the Pressure Equipment Directive 97/23/EC for compressible fluids of Group 1 (hazardous gases and vapours according to Article 3 No. 1.3 letter a first dash)
 2.) Deviation for port connections according to ASME BPE: the next largest nominal diameter is used, e.g. NPS 1 instead of NPS ¾.
 3.) Reduced spring force
 4.) Only for housing variants with nominal pressure PN 40 (optional)

Pilot pressure diagram with flow direction below seat (control function B)

Note:

d = Seat size

Actuator size Ø 50 mm

Maximum control pressure 7 bar(g)

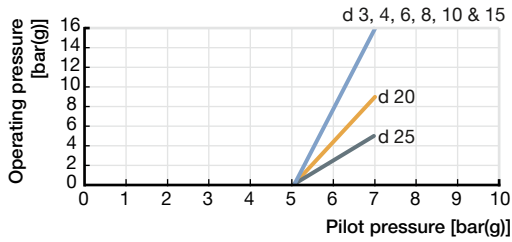

Actuator size Ø 70 mm

Maximum control pressure 7 bar(g)

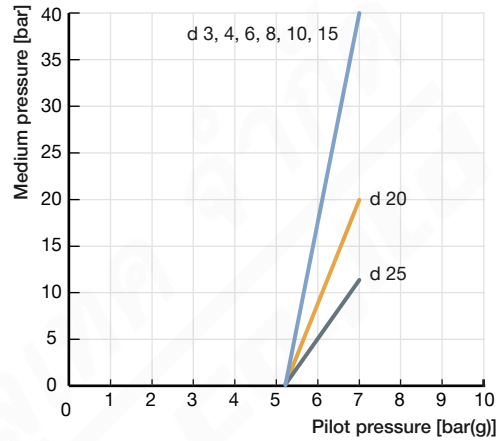

Actuator size Ø 90 mm

Maximum control pressure 7 bar(g)

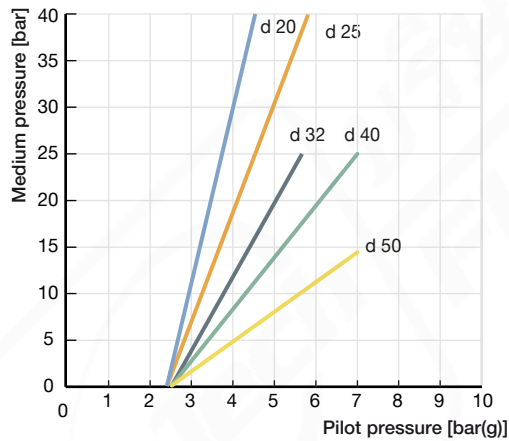

Actuator size Ø 130 mm

Maximum control pressure 7 bar(g)

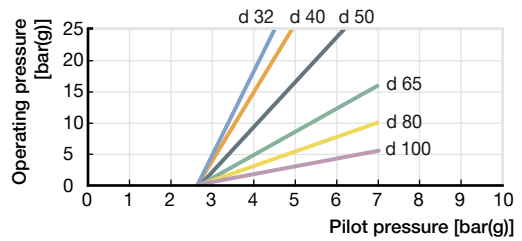

Actuator size Ø 225 mm

Maximum control pressure 5 bar(g)

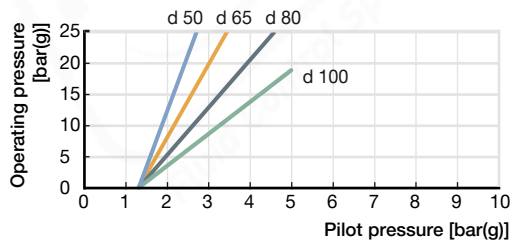

DTS 1000112693 EN Version: AI Status: RL (released | freigegeben | validé) printed: 08.05.2024

7.2. Operating limits

Operating limits for medium temperature and operating pressure

The operating range of Bürkert process valves is in addition to the maximum operating pressures limited by the nominal pressure according to the relevant standard.

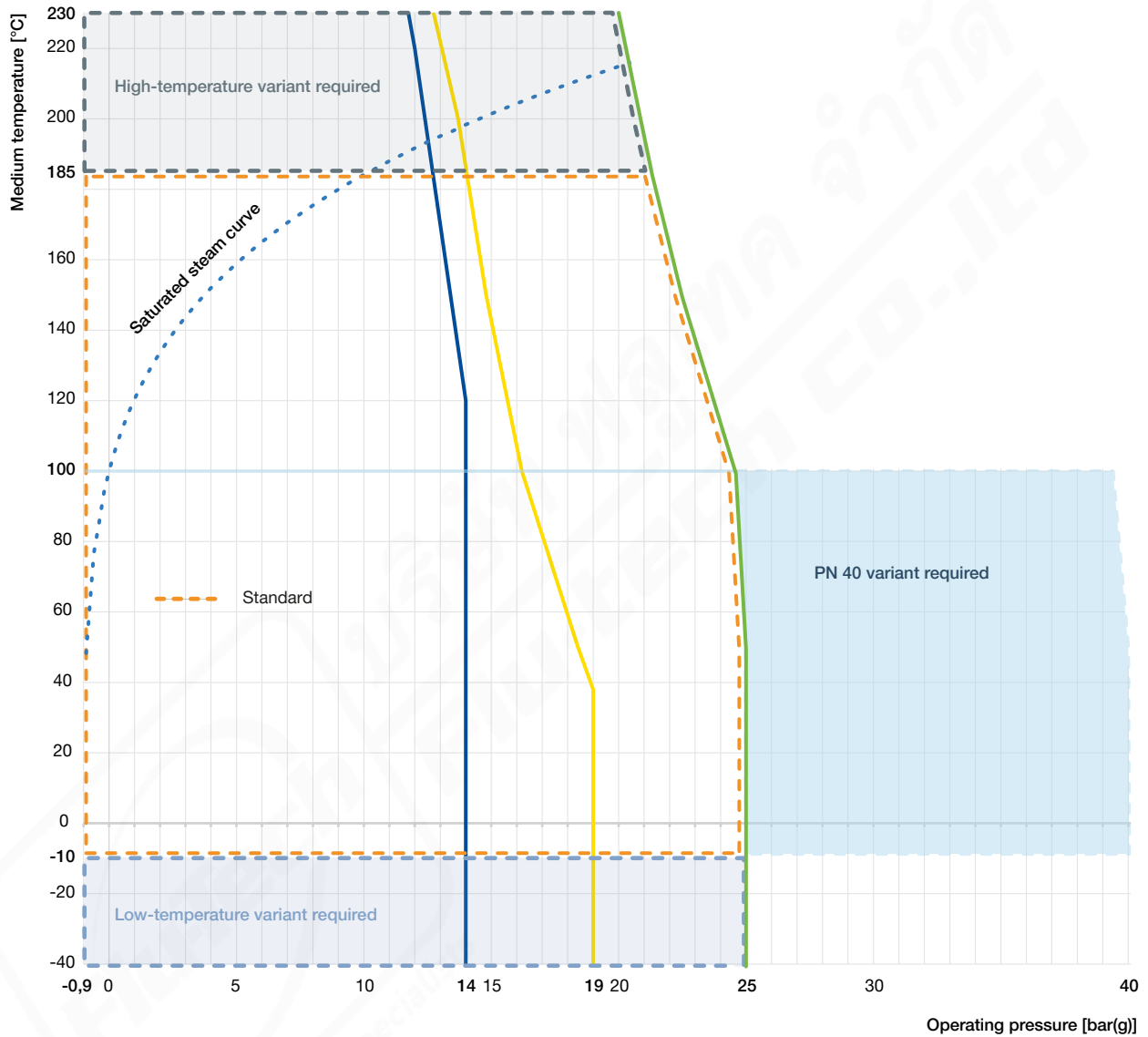

- Operating limits for PN25 according to DIN EN 12516 - 1
- Operating limits for PN40 according to DIN EN 12516 - 1
- Operating limits for flange 10K according to JIS B 2220
- Operating limits for Class 150 according to ASME B16.34
- ⋯ Saturated steam curve for water

Operating limits for ambient and medium temperature

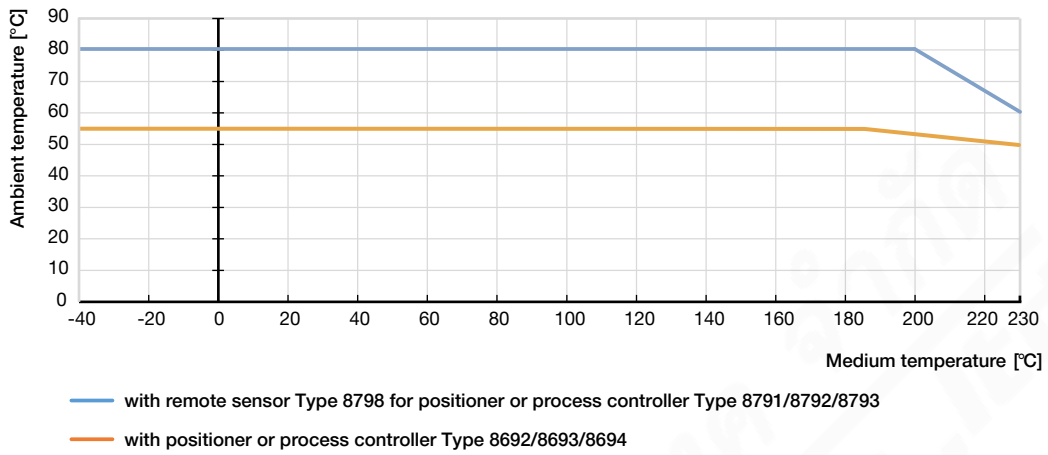

Operating limits for seat seal

Tight sealing required	Leakage class (DIN EN 60534 - 4)	Medium temperature	Seat seal
No An additional shut-off valve is recommended	III/IV (metal seals)	-40...+230 °C	Stainless steel
	Metal-sealed valves have larger leakages (0.1 % or 0.01 % of the nominal flow rate are permissible). Metallic seals are impervious even under demanding process conditions. For particularly demanding process conditions such as cavitation, erosion by wet steam or abrasive media, hardened cones and seats can be used to significantly increase the service life.		Hardened stainless steel
Yes An additional shut-off valve is often unnecessary.	VI (soft seals)	-40...+130 °C (recommended for ≤ +130 °C)	PTFE
	By using plastics as sealing material, the control valves can close tightly. Their use is not recommended in cases of increased erosion due to demanding process conditions.	-10...+230 °C (recommended for > +130 °C)	PEEK

DTS 1000112693 EN Version: AI Status: RL (released | freigegeben | validé) printed: 08.05.2024

Operating limits for optional versions

High-temperature version

Thanks to an adaption of the spindle seal, this version is suitable for applications with steam, neutral gases and other heat transfer mediums up to +230 °C.

Water version

For applications with water up to +200 °C, a special configuration of the spindle seal increases service life significantly. It is recommended for water temperatures starting at +85 °C.

Drinking water version

Wetted materials are tested in contact with the medium are tested for suitability with drinking water up to +85 °C.

Vacuum version

Without leakage bore, this design is suitable for pressures down to -0.9 bar(g).

Low-temperature version

Suitable for minimum medium temperatures down to -40 °C

Oxygen variant

Non-metallic wetted materials are tested for suitability with oxygen and are suitable for operating pressures up to 25 bar(g) and media temperatures up to +60 °C. Optional variant for operating pressures up to 40 bar(g) and media temperatures up to +100 °C on request.

Hydrogen variant

Wetted materials are tested for suitability with hydrogen and are suitable for operating pressures up to 40 bar(g) and medium temperatures up to +100 °C.

The hydrogen variant of Type 2301 is tested for an external tightness (stem seal and body seal) totalling 10⁻⁶ mbar*l/s at 40 bar, +20 °C helium and 2.78 x 10⁻³ mbar*l/s at 40 bar, -10 °C/+100 °C hydrogen. An external leak-tightness of 10⁻⁴ mbar*l/s is ensured when delivered.

8. Product accessories



Process controller TopControl	
Type 8693 ▶ Actuator size Ø 70/90/130/225 mm	
	<p>The intelligent process controller Type 8693 is designed for integrated mounting on pneumatic actuators from the process control valve series Type 23xx/2103 and especially for the requirements of hygienic process conditions. Using the TUNE functions, the positioner and process controller can be initialised automatically. Easy operation and selection of additional software functions as well as parameterisation are carried out via the large graphic display and a touch keypad. Device configuration and parameterisation can also be conveniently carried out by the Bürkert Communicator software via a PC interface.</p> <p>Features</p> <ul style="list-style-type: none"> • Contactless position sensor • Universal control system for single and double acting actuators • Highly dynamic actuating system without internal control air consumption in the balanced state • Integrated diagnostic functions for valve monitoring • Automatic initialisation of the positioner and process controller using the TUNE function • Safeguarding in the event of failure of the electrical or pneumatic auxiliary power • PROFIBUS DPV1, EtherNet/IP, PROFINET, Modbus TCP, Bürkert system bus (büS) • Compact and robust hygienic stainless steel design <p>Customer benefits</p> <ul style="list-style-type: none"> • Quick and easy commissioning • Intuitive and simple operation via a graphic display with backlight and touch keypad • High system availability due to increased drive service life by means of spring chamber ventilation • Guaranteed reliability and predictable maintenance through valve monitoring and diagnostics • Easy maintenance and process monitoring

DTS 1000112693 EN Version: AI Status: RL (released | freigegeben | validé) printed: 08.05.2024

DTS 1000112693 EN Version: AI Status: RL (released | freigeben | validé) printed: 08.05.2024

Positioner TopControl	
Type 8692 ▶ Actuator size Ø 70/90/130/225 mm	
	<p>The intelligent electropneumatic positioner Type 8692 is designed for integrated attachment to pneumatic actuators of the process control valve series Type 23xx/2103 and especially for the requirements of hygienic process conditions. The positioner can be initialised automatically using the TUNE function. Easy operation and the selection of the extensive additional software functions as well as parameterisation are carried out via the large graphic display and the touch keypad. The device configuration and parameterisation can also be conveniently carried out using the Bürkert Communicator software via a PC interface.</p> <p>Features</p> <ul style="list-style-type: none"> • Contactless position sensor • Universal positioning system for single and double-acting actuators in the balanced state • Highly dynamic positioning system without internal control air consumption • Integrated diagnostic functions for valve monitoring • Automatic initialisation of the positioner by using the TUNE function • Safeguard in the event of failure of the electrical or pneumatic auxiliary power • PROFIBUS DPV1, EtherNet/IP, PROFINET, Modbus TCP, Bürkert system bus (bÜS) • Compact and robust hygienic stainless steel design <p>Customer benefits</p> <ul style="list-style-type: none"> • Quick and easy commissioning • Intuitive and simple operation via graphic display with backlight and touch keypad • High system availability due to increased drive service life by means of spring chamber ventilation • Guaranteed reliability and predictable maintenance through valve monitoring and diagnostics
Positioner TopControl BASIC	
Type 8694 ▶ Actuator size Ø 70/90/130/225 mm	
	<p>The compact positioner Type 8694/8696 is designed for integrated attachment to pneumatic actuators of the Type 23xx/2103 process control valve series and especially for the requirements of hygienic process conditions. Operation and parameterisation are performed via push buttons and DIP switches. The device configuration and parameterisation can also be conveniently carried out using the Bürkert Communicator software via a PC interface.</p> <p>Features</p> <ul style="list-style-type: none"> • Contactless position sensor • Universal positioning system for single and double-acting actuators • Ultra dynamic positioning system without internal control air consumption • AS-Interface, IO-Link, Bürkert system bus (bÜS) (only 8694) • Compact and robust hygienic stainless steel design
Type 8696 ▶ Actuator size Ø 50 mm	
	<p>Customer benefits</p> <ul style="list-style-type: none"> • Simple and safe commissioning using the teach function • Minimum space requirement in the plant pipework for more flexibility in plant design • High system availability due to increased drive service life by means of spring chamber ventilation

DTS 1000112693 EN Version: AI Status: RL (released | freigeben | validé) printed: 08.05.2024

Process controller SideControl Remote	
Type 8793 ▶ with remote sensor 8798 ▶ Actuator size Ø 70/90/130/225 mm	
	<p>The intelligent digital positioner and process controller Type 8793 is designed for mounting on lift or swivel drives with standardisation in accordance with IEC 534 -6 or VDI/VDE 3845 for demanding control tasks. The variant with remote position sensor Type 8798 is used to control Bürkert process control valves. It is operated via a graphic display with backlight. The initialisation of the positioner and process controller can be done automatically using the TUNE function. The type of controlled system is automatically recognised and the appropriate controller structure with the corresponding optimum parameter set is determined.</p> <p>Features</p> <ul style="list-style-type: none"> • Universal control system for single and double acting actuators • Integrated diagnostic functions for valve monitoring • Automatic initialisation of the position and process controller using the TUNE function • Ultra-dynamic actuating system without internal control air consumption • Illuminated graphic display with backlight and touch keypad • PROFIBUS DPV1, EtherNet/IP, PROFINET, Modbus TCP, Bürkert system bus (bùS) • Compact and robust design • Adaptation according to IEC 534 -6 or VDI/VDE 3845 for lift and swivel drives or as remote variant on Bürkert process valves <p>Customer benefits</p> <ul style="list-style-type: none"> • Quick and easy commissioning • Intuitive and simple operation via graphic display with backlight and touch keypad • Guaranteed reliability and scheduled maintenance thanks to valve monitoring and diagnostics • Easy maintenance and process monitoring • Long service life
Positioner SideControl Remote	
Positioner Type 8792 ▶ with remote sensor Type 8798 ▶ Actuator size Ø 70/90/130/225 mm	
	<p>The intelligent digital positioner and process controller Type 8792 is designed for attachment to lift and swivel drives with standardisation according to IEC 534 -6 or VDI/VDE 3845 for demanding control tasks. The Type 8798 version with remote position sensor is used to control Bürkert process control valves. It is operated via a graphic display with backlight. The initialisation of the positioner and process controller can be done automatically by using the TUNE function.</p> <p>Features</p> <ul style="list-style-type: none"> • Illuminated graphic display with backlight and touch keypad • Universal control system for single and double acting actuators • Ultra-dynamic actuating system without internal control air consumption • Integrated diagnostic functions for valve monitoring • PROFIBUS DPV1, EtherNet/IP, PROFINET, Modbus TCP, Bürkert system bus (bùS) • Compact and robust design • Adaptation according to IEC 534 -6 or VDI/VDE 3845 for lift and swivel drives or as remote variant on Bürkert process valves <p>Customer benefits</p> <ul style="list-style-type: none"> • Quick and easy commissioning • Intuitive and simple operation via a graphic display with backlight and touch keypad • Guaranteed reliability and scheduled maintenance thanks to valve monitoring and diagnostics • Long service life

Positioner SideControl BASIC Remote

Positioner Type 8791 ▶ with remote sensor Type 8798 ▶ Actuator size Ø 70/90/130/225 mm



The intelligent digital positioner and process controller Type 8791/8798 is designed for mounting on linear and rotary actuators with standardisation in accordance with IEC 534-6 or VDI/VDE 3845 for demanding control tasks. The variant with remote position sensor Type 8798 is used for controlling Bürkert process control valves. It is operated via a graphic display with backlight. The positioner and process controller can be initialised automatically using the TUNE functions.

Features

- Simple design
- Universal control system for single and double acting actuators
- Highly dynamic actuating system without internal control air consumption in the balanced state
- Adaptation according to IEC 534-6 or VDI/VDE 3845 for lift and swivel drives or as remote variant on Bürkert process valves
- AS-Interface, IO-Link, Bürkert system bus (bÜS) (only for positioner Type 8791 BASIC Remote)

Positioner IP20 Type 8791 ▶ with remote sensor Type 8798 ▶ Actuator size Ø 70/90/130/225 mm



Customer benefits

- Simple commissioning
- Simple device for simple control tasks
- Low energy consumption

DTS 1000112693 EN Version: AI Status: RL (released | freigabegeben | validé) printed: 08.05.2024

9. Networking and combination with other Bürkert products

The **Type 2301 Globe Control Valve** can be combined with our extensive range of positioners and process controllers to form the **Continuous ELEMENT valve system, Type 8802-GD**.

The range of the control unit consists of;

- A digital electropneumatic positioner/process controller **Type 8692/8693** (for valve actuator sizes Ø 70/90/130/225 mm)
- A digital electropneumatic positioner, basic **Type 8694** (for valve actuator size Ø 70/90/130/225 mm)
- A digital electropneumatic positioner, basic **Type 8696** (for valve actuator size Ø 50 mm)
- An electropneumatic positioner, SideControl **Type 8792** or an electropneumatic process controller, **Type 8793** (for valve actuator size Ø 70/90/130/225 mm) and a remote sensor, **Type 8798**
- An electropneumatic positioner, SideControl Basic **Type 8791** (for valve actuator size Ø 70/90/130/225 mm) and a remote sensor, **Type 8798**

Note:

- For the configuration of further valve systems please use the **Product Enquiry Form** (see **"10.3. Bürkert Product Enquiry Form"** on page 29).
- You order two components and receive a completely assembled and tested valve.

Example with threaded connection

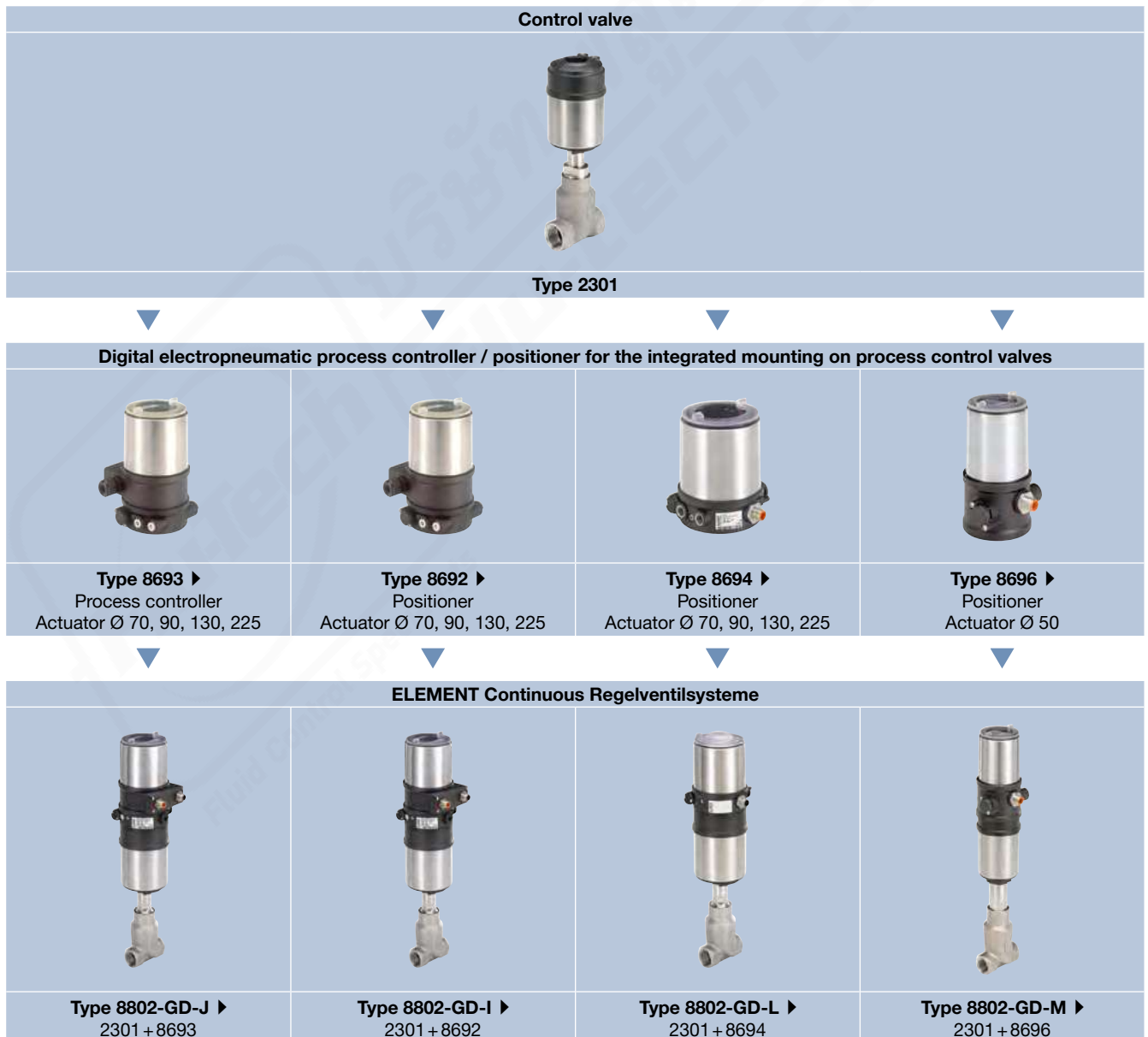

DTS 1000112693 EN Version: AI Status: RL (released | freigeben | validé) printed: 08.05.2024

Control valve



Type 2301

Digital electropneumatic process controller / positioner SideControl



Type 8793 ▶
Process controller
+
Type 8798 ▶
Remote sensor
Actuator Ø 70, 90, 130, 225



Type 8792 ▶
Positioner
+
Type 8798 ▶
Remote sensor
Actuator Ø 70, 90, 130, 225



Type 8791 ▶
Positioner
+
Type 8798 ▶
Remote sensor
Actuator Ø 70, 90, 130, 225

oder



SideControl Basic IP20
Positioner
Actuator Ø 50

ELEMENT Continuous control valve system



Type 8802-GD-Q ▶
2301 + 8793 + 8798



Type 8802-GD-P ▶
2301 + 8792 + 8798



Type 8802-GD-O ▶
2301 + 8791 + 8798

10. Ordering information

10.1. Bürkert eShop



Bürkert eShop – Easy ordering and quick delivery

You want to find your desired Bürkert product or spare part quickly and order directly? Our online shop is available for you 24/7. Sign up and enjoy all the benefits.

[Order online now](#)

10.2. Bürkert product filter



Bürkert product filter – Get quickly to the right product

You want to select products comfortably based on your technical requirements? Use the Bürkert product filter and find suitable articles for your application quickly and easily.

[Try out our product filter](#)

10.3. Bürkert Product Enquiry Form

Note:

Please see our Product Enquiry Form for a full explanation of our specification key.

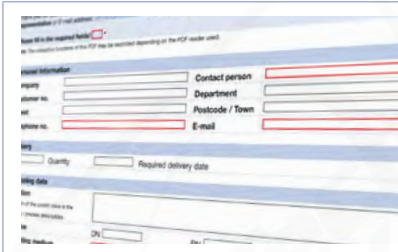

Bürkert Product Enquiry Form – Your enquiry quickly and compactly

Would you like to make a specific product enquiry based on your technical requirements? Use our Product Enquiry Form for this purpose. There you will find all the relevant information for your Bürkert contact. This will enable us to provide you with the best possible advice.

[Fill out the form now](#)

DTS 1000112693 EN Version: AI Status: RL (released | freigegeben | validé) printed: 08.05.2024

10.4. Ordering chart flange connection

Valve with flow direction below seat

Nominal diameter (port connection)		Seat size	Actuator size Ø	K _{vs} value	Article no.	
DN	NPS				Seat seal	
DIN EN 1092 - 1			[mm]	[m ³ /h]	PTFE	Stainless steel
10	⅜	3	70 (M)	0.1	-	o. r.
		3	70 (M)	0.2	-	o. r.
		4	70 (M)	0.5	-	o. r.
		6	70 (M)	1.25	370257 ₺	350725 ₺
		8	70 (M)	2	213985 ₺	215212 ₺
		10	70 (M)	2.7	213989 ₺	215215 ₺
15	½	3	70 (M)	0.1	-	o. r.
		3	70 (M)	0.2	-	o. r.
		4	70 (M)	0.5	-	o. r.
		6	70 (M)	1.25	234255 ₺	378904 ₺
		8	70 (M)	2.1	213987 ₺	215214 ₺
		10	70 (M)	3.1	213991 ₺	215217 ₺
		15	70 (M)	4.3	204932 ₺	205010 ₺
20	¾	10	70 (M)	3.2	210530 ₺	215218 ₺
		15	70 (M)	5.2	213993 ₺	214030 ₺
		20	70 (M)	7.1	204935 ₺	205012 ₺
25	1	15	70 (M)	5.3	213994 ₺	214031 ₺
		20	70 (M)	7.2	213995 ₺	214032 ₺
		25	70 (M)	12	204937 ₺	205014 ₺
		90 (N)	12	242054 ₺	229421 ₺	
32	1¼	25	90 (N)	8.9	213997 ₺	210446 ₺
			130 (P)	13	222634 ₺	222655 ₺
		32	90 (N)	13.4	204939 ₺	205016 ₺
			130 (P)	17.8	223597 ₺	223598 ₺
40	1½	32	90 (N)	14.4	213999 ₺	214035 ₺
			130 (P)	20.2	222636 ₺	222657 ₺
		40	90 (N)	17.5	204941 ₺	205018 ₺
			130 (P)	23.8	219791 ₺	222659 ₺
50	2	40	90 (N)	18	214001 ₺	214037 ₺
			130 (P)	24.6	222638 ₺	222660 ₺
		50	90 (N)	28	204942 ₺	205019 ₺
			130 (P)	37	214003 ₺	214039 ₺
			225 (L)	39.5	20060552 ₺	20060584 ₺
65	2½	50	130 (P)	65	217772 ₺	219618 ₺
			225 (L)	62	20060553 ₺	20060585 ₺
		65	130 (P)	73	239545 ₺	239581 ₺
			225 (L)	70	20060554 ₺	20060587 ₺
80	3	65	130 (P)	100	239540 ₺	239576 ₺
			225 (L)	100	20060555 ₺	20060589 ₺
		80	130 (P)	110	239561 ₺	239597 ₺
			225 (L)	115	20060556 ₺	20060590 ₺
			100	140	239556 ₺	331125 ₺
100	4	80	130 (P)	140	20060557 ₺	20060591 ₺
			225 (L)	140	20060557 ₺	20060591 ₺

Nominal diameter (port connection)		Seat size	Actuator size Ø	K _{vs} value	Article no.	
DN	NPS				Seat seal	
			[mm]	[m ³ /h]	PTFE	Stainless steel
JIS 10K						
15	½	3	70 (M)	0.1	-	o. r.
		3	70 (M)	0.2	-	o. r.
		4	70 (M)	0.5	-	o. r.
		6	70 (M)	1.25	367023 ㉞	o. r.
		8	70 (M)	2.1	215203 ㉞	215228 ㉞
		10	70 (M)	3.1	213913 ㉞	213911 ㉞
		15	70 (M)	4.3	204953 ㉞	205030 ㉞
20	¾	10	70 (M)	3.2	215204 ㉞	215229 ㉞
		15	70 (M)	5.2	213936 ㉞	213933 ㉞
		20	70 (M)	7.1	204955 ㉞	205032 ㉞
25	1	15	70 (M)	5.3	214020 ㉞	214059 ㉞
		20	70 (M)	7.2	213930 ㉞	213914 ㉞
		25	70 (M)	12	204957 ㉞	205034 ㉞
			90 (N)	12	242165 ㉞	242199 ㉞
32	1¼	25	90 (N)	8.9	213939 ㉞	213937 ㉞
			130 (P)	13	222643 ㉞	222665 ㉞
		32	90 (N)	13.4	213177 ㉞	213178 ㉞
			130 (P)	17.8	222645 ㉞	222667 ㉞
40	1½	32	90 (N)	14.4	213932 ㉞	213931 ㉞
			130 (P)	20.2	222647 ㉞	222668 ㉞
		40	90 (N)	17.5	204959 ㉞	205037 ㉞
			130 (P)	23.8	222649 ㉞	222670 ㉞
50	2	40	90 (N)	18	213941 ㉞	213940 ㉞
			130 (P)	24.6	222650 ㉞	222671 ㉞
		50	90 (N)	28	204960 ㉞	205038 ㉞
			130 (P)	37	214023 ㉞	214062 ㉞
			50	45	214024 ㉞	214063 ㉞
65	2½	50	130 (P)	45	214024 ㉞	214063 ㉞
			225 (L)	39.5	20060565 ㉞	20060599 ㉞
		65	130 (P)	65	219617 ㉞	219620 ㉞
80	3	65	225 (L)	62	20060568 ㉞	20060600 ㉞
			130 (P)	73	239547 ㉞	239584 ㉞
		80	225 (L)	70	20060569 ㉞	20060601 ㉞
			130 (P)	100	239542 ㉞	239578 ㉞
			225 (L)	100	20060570 ㉞	20060602 ㉞
100	4	80	130 (P)	110	239563 ㉞	239599 ㉞
			225 (L)	115	20060571 ㉞	20060604 ㉞
		100	130 (P)	140	239558 ㉞	239594 ㉞
			225 (L)	140	20060572 ㉞	20060605 ㉞

o. r. = on request

DTS 1000112693 EN Version: AI Status: RL (released | freigeben | valide) printed: 08.05.2024

Nominal diameter (port connection)		Seat size	Actuator size Ø	K _{vs} value	Article no.	
DN	NPS				Seat seal	
			[mm]	[m ³ /h]	PTFE	Stainless steel
ANSI B 16.5						
15	½	3	70 (M)	0.1	-	o. r.
			70 (M)	0.2	-	o. r.
			70 (M)	0.5	-	o. r.
		4	70 (M)	1.25	367211	380948
			70 (M)	2.1	215198	215221
			70 (M)	3.1	215199	215222
			70 (M)	4.3	204944	205021
20	¾	10	70 (M)	3.2	215200	215223
			70 (M)	5.2	214009	214046
			70 (M)	7.1	204946	205023
25	1	15	70 (M)	5.3	214010	214047
			70 (M)	7.2	214011	214048
		25	70 (M)	12	204948	205025
			90 (N)	12	464851	464367
40	1½	32	90 (N)	14.4	215201	215224
			130 (P)	20.2	463905	463913
		40	90 (N)	17.5	204950	205027
			130 (P)	23.8	463907	463915
50	2	40	90 (N)	18	214013	214050
			130 (P)	24.6	463908	463916
		50	90 (N)	28	204951	205028
			130 (P)	37	214015	214052
65	2½	50	130 (P)	45	239537	239573
			225 (L)	39.5	20060558	20060592
		65	130 (P)	65	239535	239572
			225 (L)	62	20060559	20060594
80	3	65	130 (P)	73	239546	239582
			225 (L)	70	20060560	20060595
		80	130 (P)	100	239541	239577
			225 (L)	100	20060562	20060596
100	4	80	130 (P)	110	239562	239598
			225 (L)	115	20060563	20060597
		100	130 (P)	140	239557	239593
			225 (L)	140	20060564	20060598

o. r. = on request

Further versions on request	
Approval FDA, ATEX, (EG Gas Appliances Directive 2009/142/EG)	Control function/Circuit function B (normally open: NO)
Process connection Further housing connections	

DTS 1000112693 EN Version: AI Status: RL (released | freigeben | validé) printed: 08.05.2024

10.5. Ordering chart threaded connection

Valve with flow direction below seat

Nominal diameter (port connection)		Seat size	Actuator size Ø	K _{vs} value	Article no.	
DN	NPS				Seat seal	
			[mm]	[m ³ /h]	PTFE	Stainless steel
DIN EN ISO 228 - 1						
10	3/8	3	70 (M)	0.1	-	o. r.
		3	70 (M)	0.2	-	o. r.
		4	70 (M)	0.5	-	o. r.
		6	70 (M)	1.25	322059	350407
		8	70 (M)	2	215233	215242
		10	70 (M)	2.7	215235	215245
15	1/2	3	70 (M)	0.1	-	o. r.
		3	70 (M)	0.2	-	o. r.
		4	70 (M)	0.5	-	o. r.
		6	70 (M)	1.25	236138	354643
		8	70 (M)	2.1	212964	215243
		10	70 (M)	3.1	215236	215246
20	3/4	15	70 (M)	4.3	206432	213955
		10	70 (M)	3.2	215237	215247
		15	70 (M)	5.2	214067	215248
25	1	20	70 (M)	7.1	206584	211239
		15	70 (M)	5.3	206588	210460
		20	70 (M)	7.2	206586	210721
		25	70 (M)	12	189145	210485
32	1 1/4	25	90 (N)	12	242203	242207
			130 (P)	13	222677	222687
		32	90 (N)	13.4	210097	210458
			130 (P)	17.8	223599	223600
40	1 1/2	32	90 (N)	14.4	214072	214084
			130 (P)	20.2	222679	222689
		40	90 (N)	17.5	210098	207800
			130 (P)	23.8	222681	222691
50	2	40	90 (N)	18	214074	214086
			130 (P)	24.6	222682	222692
		50	90 (N)	28	210099	203693
			130 (P)	37	214076	214088
65	2 1/2	50	130 (P)	45	214077	214089
		65	130 (P)	65	219621	219622

DTS 1000112693 EN Version: AI Status: RL (released | freigeben | validé) printed: 08.05.2024

Nominal diameter (port connection)		Seat size	Actuator size Ø	K _{vs} value	Article no.	
DN	NPS				Seat seal	
			[mm]	[m ³ /h]	PTFE	Stainless steel
ISO 7/1 / DIN EN 10226 - 2						
10	3/8	3	70 (M)	0.1	-	o. r.
		3	70 (M)	0.2	-	o. r.
		4	70 (M)	0.5	-	o. r.
		6	70 (M)	1.25	o. r.	o. r.
		8	70 (M)	2	220418	220453
		10	70 (M)	2.7	220421	220457
15	1/2	3	70 (M)	0.1	-	o. r.
		3	70 (M)	0.2	-	o. r.
		4	70 (M)	0.5	-	o. r.
		6	70 (M)	1.25	o. r.	o. r.
		8	70 (M)	2.1	220881	220455
		10	70 (M)	3.1	220423	220459
		15	70 (M)	4.3	220882	220886
20	3/4	10	70 (M)	3.2	220425	220461
		15	70 (M)	5.2	220427	220463
		20	70 (M)	7.1	220430	220466
25	1	15	70 (M)	5.3	220428	220464
		20	70 (M)	7.2	220431	220467
		25	70 (M)	12	220434	220470
		90 (N)	12	464864	464867	
32	1 1/4	25	90 (N)	8.9	220435	220471
			130 (P)	13	463921	463931
		32	90 (N)	13.4	220437	220473
			130 (P)	17.8	463956	463957
40	1 1/2	32	90 (N)	14.4	220438	463803
			130 (P)	20.2	463923	463933
		40	90 (N)	17.5	220440	220476
			130 (P)	23.8	463925	463935
50	2	40	90 (N)	18	220441	220477
			130 (P)	24.6	463926	463936
		50	90 (N)	28	220443	220479
			130 (P)	37	220444	220480
65	2 1/2	50	130 (P)	45	239536	239620
		65	130 (P)	65	239534	239571

o. r. = on request

DTS 1000112693 EN Version: AI Status: RL (released | freigeben | validé) printed: 08.05.2024

Nominal diameter (port connection)		Seat size	Actuator size Ø	K _{vs} value	Article no. RC (ASME B 1.20.1)	
DN	NPS				Seat seal	
			[mm]	[m ³ /h]	PTFE	Stainless steel
ASME B 1.20.1						
10	3/8	3	70 (M)	0.1	-	o. r.
		3	70 (M)	0.2	-	o. r.
		4	70 (M)	0.5	-	o. r.
		6	70 (M)	1.25	o. r.	o. r.
		8	70 (M)	2	220484	220519
		10	70 (M)	2.7	220487	220523
15	1/2	3	70 (M)	0.1	-	o. r.
		3	70 (M)	0.2	-	o. r.
		4	70 (M)	0.5	-	o. r.
		6	70 (M)	1.25	359073	388407
		8	70 (M)	2.1	220888	220521
		10	70 (M)	3.1	220489	220525
		15	70 (M)	4.3	220889	220894
20	3/4	10	70 (M)	3.2	220491	220527
		15	70 (M)	5.2	220493	220529
		20	70 (M)	7.1	220496	220532
25	1	15	70 (M)	5.3	220494	220530
		20	70 (M)	7.2	220497	220533
		25	70 (M)	12	220500	220536
			90 (N)	12	242377	242380
32	1 1/4	25	90 (N)	8.9	220501	220537
			130 (P)	13	222740	222777
		32	90 (N)	13.4	220503	220539
			130 (P)	17.8	223605	223606
40	1 1/2	32	90 (N)	14.4	220504	220540
			130 (P)	20.2	222742	222763
		40	90 (N)	17.5	220506	220542
			130 (P)	23.8	222765	222767
50	2	40	90 (N)	18	220507	220543
			130 (P)	24.6	222768	222766
		50	90 (N)	28	220509	220545
			130 (P)	37	220510	220546
65	2 1/2	50	130 (P)	45	220511	220547
		65	130 (P)	65	220512	220548

o. r. = on request

Further versions on request	
Approval FDA, ATEX, (EG Gas Appliances Directive 2009/142/EG)	Control function/Circuit function B (normally open: NO)
Process connection Further housing connections	

DTS 1000112693 EN Version: AI Status: RL (released | freigeben | validé) printed: 08.05.2024

10.6. Ordering chart welded connection

Valve with flow direction below seat

Nominal diameter (port connection)		Seat size	Actuator size Ø	K _{vs} value	Connection MW x TW	Article no.	
DN	NPS					Seat seal	
			[mm]	[m ³ /h]		PTFE	Stainless steel
DIN EN ISO 1127 - 1 / ISO 4200 / DIN 11866 Reihe B							
10	3/8	3	70 (M)	0.1	17.2 x 1.6	-	o. r.
		3	70 (M)	0.2	17.2 x 1.6	-	o. r.
		4	70 (M)	0.5	17.2 x 1.6	-	o. r.
		6	70 (M)	1.25	17.2 x 1.6	232888 ☞	378908 ☞
		8	70 (M)	2	17.2 x 1.6	232891 ☞	315915 ☞
		10	70 (M)	2.7	17.2 x 1.6	o. r.	337061 ☞
15	1/2	3	70 (M)	0.1	21.3 x 1.6	-	o. r.
		3	70 (M)	0.2	21.3 x 1.6	-	o. r.
		4	70 (M)	0.5	21.3 x 1.6	-	o. r.
		6	70 (M)	1.25	21.3 x 1.6	288140 ☞	360750 ☞
		8	70 (M)	2.1	21.3 x 1.6	212392 ☞	216407 ☞
		10	70 (M)	3.1	21.3 x 1.6	212393 ☞	215873 ☞
		15	70 (M)	4.3	21.3 x 1.6	209571 ☞	216409 ☞
20	3/4	15	70 (M)	5.2	26.9 x 1.6	214094 ☞	214132 ☞
		20	70 (M)	7.1	26.9 x 1.6	214096 ☞	210696 ☞
25	1	20	70 (M)	7.2	33.7 x 2.0	214097 ☞	214135 ☞
		25	70 (M)	12	33.7 x 2.0	209572 ☞	214138 ☞
32	1 1/4	25	90 (N)	8.9	42.4 x 2.0	214101 ☞	214139 ☞
		32	90 (N)	13.4	42.4 x 2.0	214103 ☞	214141 ☞
40	1 1/2	32	90 (N)	14.4	48.3 x 2.0	214104 ☞	214142 ☞
			130 (P)	20.2	48.3 x 2.0	222700 ☞	222721 ☞
		40	90 (N)	17.5	48.3 x 2.0	209440 ☞	214144 ☞
			130 (P)	23.8	48.3 x 2.0	222702 ☞	222723 ☞
50	2	40	90 (N)	18	60.3 x 2.0	210756 ☞	213561 ☞
			130 (P)	24.6	60.3 x 2.0	222703 ☞	222724 ☞
		50	90 (N)	28	60.3 x 2.0	214107 ☞	214146 ☞
			130 (P)	37	60.3 x 2.0	214108 ☞	214147 ☞
65	2 1/2	65	130 (P)	65	76.1 x 2.3	219623 ☞	219626 ☞
			225 (L)	62	76.1 x 2.3	20060573 ☞	20060607 ☞
80	3	80	130 (P)	100	88.9 x 2.3	239543 ☞	239579 ☞
			225 (L)	100	88.9 x 2.3	20060574 ☞	20060608 ☞
100	4	100	130 (P)	140	114.3 x 2.6	239559 ☞	239595 ☞
			225 (L)	140	114.3 x 2.6	20060575 ☞	20060609 ☞

Nominal diameter (port connection)		Seat size	Actuator size Ø [mm]	K _{vs} value [m ³ /h]	Connection MW x TW	Article no. Seat seal	
DN	NPS					PTFE	Stainless steel
DIN 11850-2 / DIN 11866 Reihe A / DIN EN 10357 Reihe A							
10	3/8	3	70 (M)	0.1	13.0 x 1.5	-	o. r.
		3	70 (M)	0.2	13.0 x 1.5	-	o. r.
		4	70 (M)	0.5	13.0 x 1.5	-	o. r.
		6	70 (M)	1.25	13.0 x 1.5	260632 𠄎	357231 𠄎
		8	70 (M)	2	13.0 x 1.5	300236 𠄎	284179 𠄎
		10	70 (M)	2.7	13.0 x 1.5	257412 𠄎	208553 𠄎
15	1/2	3	70 (M)	0.1	19.0 x 1.5	-	o. r.
		3	70 (M)	0.2	19.0 x 1.5	-	o. r.
		4	70 (M)	0.5	19.0 x 1.5	-	o. r.
		6	70 (M)	1.25	19.0 x 1.5	248881 𠄎	367704 𠄎
		8	70 (M)	2.1	19.0 x 1.5	215250 𠄎	215911 𠄎
		10	70 (M)	3.1	19.0 x 1.5	215251 𠄎	215913 𠄎
20	3/4	15	70 (M)	4.3	19.0 x 1.5	215253 𠄎	209173 𠄎
		20	70 (M)	5.2	23.0 x 1.5	214113 𠄎	208555 𠄎
		20	70 (M)	7.1	23.0 x 1.5	211937 𠄎	211953 𠄎
		25	70 (M)	7.2	29.0 x 1.5	214116 𠄎	214154 𠄎
		25	70 (M)	12	29.0 x 1.5	209384 𠄎	209089 𠄎
		32	1 1/4	25	90 (N)	8.9	35.0 x 1.5
32	90 (N)			13.4	35.0 x 1.5	211965 𠄎	209181 𠄎
40	1 1/2	32	90 (N)	14.4	41.0 x 1.5	214121 𠄎	213487 𠄎
			130 (P)	20.2	41.0 x 1.5	222711 𠄎	222732 𠄎
		40	90 (N)	17.5	41.0 x 1.5	211967 𠄎	209110 𠄎
			130 (P)	23.8	41.0 x 1.5	222713 𠄎	222734 𠄎
50	2	40	90 (N)	18	53.0 x 1.5	214123 𠄎	213411 𠄎
			130 (P)	24.6	53.0 x 1.5	222714 𠄎	222735 𠄎
		50	90 (N)	28	53.0 x 1.5	211968 𠄎	209185 𠄎
			130 (P)	37	53.0 x 1.5	214125 𠄎	214159 𠄎
65	2 1/2	65	130 (P)	65	70.0 x 2.0	219625 𠄎	219628 𠄎
			225 (L)	62	70.0 x 2.0	20060577 𠄎	20060610 𠄎
80	3	80	130 (P)	100	85.0 x 2.0	239544 𠄎	239580 𠄎
			225 (L)	100	85.0 x 2.0	20060578 𠄎	20060612 𠄎
100	4	100	130 (P)	140	104.0 x 2.0	239560 𠄎	239596 𠄎
			225 (L)	140	104.0 x 2.0	20060580 𠄎	20060613 𠄎

o. r. = on request

Nominal diameter (port connection)	Seat size	Actuator size Ø	K _{vs} value	Connection Ø DS x WS	Operating pressure	Article no.	
						Seat seal	
NPS		[mm]	[m³/h]			PTFE (VI)	Stainless steel (IV)
ASME BPE / DIN 11866 Reihe C							
½	3	70 (M)	0.1	12.7 x 1.65	25 (IV)	–	o. r.
	3	70 (M)	0.2	12.7 x 1.65	–	–	o. r.
	4	70 (M)	0.5	12.7 x 1.65	25 (IV)	–	o. r.
	6	70 (M)	1.25	12.7 x 1.65	25 (IV)	226651 𠄎	20001538 𠄎
	8	70 (M)	2	12.7 x 1.65	25 (IV)	379940 𠄎	216879 𠄎
	10	70 (M)	2.7	12.7 x 1.65	25 (IV)	225463 𠄎	313806 𠄎
¾	10	70 (M)	3.1	19.05 x 1.65	25 (IV)	241143 𠄎	o. r.
	15	70 (M)	4.3	19.05 x 1.65	25 (IV)	335739 𠄎	335741 𠄎
1	10	70 (M)	3.2	25.4 x 1.65	25 (IV)	241633 𠄎	242576 𠄎
	15	70 (M)	5.2	25.4 x 1.65	25 (IV)	226329 𠄎	242579 𠄎
	20	70 (M)	7.1	25.4 x 1.65	16 (IV)	230405 𠄎	216902 𠄎
1½	32	90 (N)	13.4	38.1 x 1.65	16 (IV)	230409 𠄎	242587 𠄎
		130 (P)	17.8	38.1 x 1.65	25 (IV)	242557 𠄎	242589 𠄎
2	40	90 (N)	17.5	50.8 x 1.65	12 (IV)	211655 𠄎	242592 𠄎
		130 (P)	23.8	50.8 x 1.65	25 (IV)	242561 𠄎	242593 𠄎
2½	50	130 (P)	37	63.5 x 1.65	25 (20 ^{1.)}) (IV)	335735 𠄎	335737 𠄎
3	65	130 (P)	65	76.2 x 1.65	16 (15 ^{1.)}) (IV)	268682 𠄎	350667 𠄎
		225 (L)	62	76.2 x 1.65	–	20060581 𠄎	20060615 𠄎
4	80	130 (P)	110	101.6 x 2.11	10 (IV)	298386 𠄎	o. r.
		225 (L)	115	101.6 x 2.11	–	20060582 𠄎	20060616 𠄎
	100	130 (P)	140	101.6 x 2.11	6 (IV)	275103 𠄎	289251 𠄎
		225 (L)	140	101.6 x 2.11	–	20060583 𠄎	20060617 𠄎

o. r. = on request

1.) According to the Pressure Equipment Directive 97/23/EC for compressible fluids of Group 1 (hazardous gases and vapours according to Article 3 No. 1.3 letter a first dash)

Further versions on request	
Approval FDA, ATEX, (EG Gas Appliances Directive 2009/142/EG)	Control function/Circuit function B (normally open: NO)
Process connection Further housing connections	

DTS 1000112693 EN Version: AI Status: RL (released | freigeben | validé) printed: 08.05.2024

10.7. Ordering chart clamp connection

Valve with flow direction below seat

Nominal diameter (port connection)		Seat size	Actuator size Ø [mm]	K _{vs} value [m³/h]	Connection MC x TC, CC	Article no. Seat seal	
DN	NPS					PTFE	Stainless steel
DIN 32676 Reihe A							
15	½	15	70 (M)	4.3	19 x 1.5. 34	222593	282208
20	¾	20	70 (M)	7.1	23 x 1.5. 34	225647	282209
25	1	25	90 (N)	12.0	29 x 1.5. 50.5	222594	282210
32	1¼	32	90 (N)	13.4	35 x 1.5. 50.5	240415	282211
40	1½	40	130 (P)	23.8	41 x 1.5. 50.5	240351	282212
50	2	50	130 (P)	37.0	53 x 1.5. 64	282258	282259
DIN 32676 Reihe B							
15	½	15	70 (M)	4.3	21.3 x 1.6. 50.5	273974	282213
20	¾	20	70 (M)	7.1	26.9 x 1.6. 50.5	209438	282214
25	1	25	90 (N)	12.0	33.7 x 2.0. 50.5	241115	282215
40	1½	40	130 (P)	23.8	48.3 x 2.0. 64.0	209880	284181
50	2	50	130 (P)	37.0	60.3 x 2.0. 77.5	282261	282263

Further versions on request	
Approval FDA, ATEX, (EG Gas Appliances Directive 2009/142/EG)	Control function/Circuit function B (normally open: NO)
Process connection Further housing connections	

DTS 1000112693 EN Version: AI Status: RL (released | freigeben | validé) printed: 08.05.2024