



### Direct-acting 2/2 or 3/2-way pivoted armature valve

- Direct-acting, media-separated valve up to DN 5
- Maintenance-free pivoted armature technology
- Vibration-proof, block screwed solenoid system
- Service-friendly, robust manual override
- Explosion-proof variants

Product variants described in the data sheet may differ from the product presentation and description.

#### Can be combined with

	<b>Type 1087</b> Timer, form A according to DIN EN 175301 - 803	▶
	<b>Type 2518</b> Cable plug, form A according to DIN EN 175301 - 803	▶
	<b>Type 2509</b> Cable plug, form A according to DIN EN 175301 - 803	▶

#### Type description

The 0330 valve is a direct-acting, media-separated pivoted armature valve. It is available as a 2/2 and 3/2-way variant. As a 3/2-way variant, it can be used as a distributor or mixing valve. Various diaphragm materials and circuit functions are available depending on the actual application. Brass, stainless steel, PEEK and polypropylene bodies are offered. The solenoid coils are moulded with a chemically resistant epoxy. Since the coil system is separated from the medium by a diaphragm, the valve is especially suitable for critical media such as aggressive acids and lyes. The 0330 is equipped with manual override for start-up and testing. To reduce energy demands, all the coils can be delivered with electronic power reduction or as an impulse variant. The switching status can be indicated via position feedback as a binary or NAMUR signal.

DTS 1000598012 EN Version: B Status: RL (released | freigegeben | validé) printed: 28.03.2024

**FLU-TECH CO. LTD.**

**Email:** sales@flutech.co.th **Website:** https://flutech.co.th

**Tel:** 02-384-6060, 086-369-5871-3 **Fax:** 02-384-5701 **LINE OA:** @flutech.co.th

**Address (HQ):** 845/3-4, Moo 3, Theparak Rd., T. Theparak, A. Mueang Samut Prakan, Samut Prakan, 10270, Thailand

LINE OA

WEBSITE



## Table of contents

<b>1. General technical data</b>	<b>4</b>
<b>2. Circuit functions</b>	<b>5</b>
<b>3. Approvals and conformities</b>	<b>6</b>
3.1. General notes.....	6
3.2. Conformity.....	6
3.3. Standards.....	6
3.4. Explosion protection.....	6
3.5. North America (USA/Canada).....	7
3.6. Others.....	7
DNV GL classification.....	7
<b>4. Materials</b>	<b>8</b>
4.1. Bürkert resistApp.....	8
4.2. Material specifications.....	8
<b>5. Dimensions</b>	<b>9</b>
5.1. Standard version.....	9
Metal body.....	9
Plastic body.....	10
Cable version.....	11
5.2. Explosion-proof version.....	12
Terminal box version.....	12
Cable version.....	13
<b>6. Device/Process connections</b>	<b>14</b>
6.1. Pin assignment standard version.....	14
6.2. Pin assignment explosion-proof version.....	14
<b>7. Performance specifications</b>	<b>15</b>
7.1. Pressure range and flow rate.....	15
Standard version.....	15
Explosion-proof version.....	16
Use in other circuit functions.....	16
<b>8. Product accessories</b>	<b>17</b>
8.1. Accessories standard version.....	17
8.2. Accessories explosion-proof version.....	17
8.3. Cable glands for ATEX/IECEx terminal box.....	18
8.4. Special tool to turn the terminal box.....	18

<b>9. Ordering information</b>	<b>19</b>
9.1. Bürkert eShop .....	19
9.2. Bürkert product filter .....	19
9.3. Bürkert Product Enquiry Form .....	19
9.4. Ordering chart .....	20
UL Recognized (UR) and CSA approval .....	20
Coil UL Listed (cULus) for hazardous locations, Class I, Division 2 .....	22
9.5. Ordering chart accessories .....	23
Cable plug Type 2518, form A according to DIN EN 175301 - 803 .....	23
Cable plug Type 2509, form A according to DIN EN 175301 - 803 .....	23
Cable glands for ATEX/IECEX terminal box .....	23
Mounting plate complete for DIN rail mounting .....	24
Locking ring .....	24

DTS 1000598012 EN Version: B Status: RL (released | freigegeben | validé) printed: 28.03.2024



## 1. General technical data

Product properties	
Dimensions	Further information can be found in chapter "5. Dimensions" on page 9.
<b>Material</b>	
Seal	EPDM FKM FFKM NBR
Body	Brass Stainless steel 1.4401/316 PP (Polypropylene) PVDF (on request) PEEK
Material resistance	Further information can be found in chapter "4.1. Bürkert resistApp" on page 8.
<b>Weight</b>	
Standard version	Metal body: 0.99 lb Plastic body: 0.66 lb
Explosion-proof version	Metal body: 1.65 lb Plastic body: 1.32 lb
Orifice	DN 2...DN 5
Circuit function	Further information can be found in chapter "2. Circuit functions" on page 5.
Thermal insulation class of solenoid coil	Epoxy coil class H
Performance data	
<b>Duty cycle</b>	
With brass, stainless steel and PEEK	100 %
With PP and PVDF	40 % duty cycle (60 % intermittent operation) in 30 min for 8 W version 100 % duty cycle for 5 W version
Switching frequency (explosion-proof version)	Medium temperature up to +158 °F: max. 20/min Medium temperature up to +194 °F: max. 5/min
<b>Switching time<sup>1)</sup> standard version</b>	
Frequency AC	Opening: 8...15 ms Closing: 8...15 ms
Frequency DC	Opening: 10...20 ms Closing: 10...20 ms
<b>Switching time<sup>1)</sup> explosion-proof version</b>	
Orifice DN 2...DN 4	Opening: 30 ms Closing: 40 ms
Electrical data	
<b>Power consumption standard</b>	
Frequency AC	Inrush: 30 VA Hold: 15 VA Hold: 8 W
Frequency DC	Cold: 11 W Warm: 8 W
<b>Power consumption impulse (inrush winding)</b>	
Frequency AC	Hold: 20 VA Hold: 11 W
Frequency DC	Cold: 11 W Warm: 8 W
<b>Power consumption explosion-proof version</b>	
Frequency AC/DC	Inrush: 40 W Hold: 3 W
<b>Voltage</b>	
Standard version	24 V/50 Hz, 110 V/50 Hz, 230 V/50 Hz, 120 V/60 Hz, 240 V/60 Hz, 12 V/DC, 24 V/DC (further voltages on request)
Explosion-proof version	24 V, 230 V (further voltages on request)
Voltage tolerance	± 10 %

**Medium data**

<b>Operating medium</b>	
With NBR	Neutral medium such as compressed air, town gas, water, hydraulic oil, oils and greases without additives, oxygen
With EPDM	Alkalis, acids to medium concentrations, alkaline washing and bleaching lyes
With FKM	Oxydizing acids and substances, hot oils with additives, salt solutions, waste gases, oxygen
With FFKM	Aggressive mediums, hot air, hot oils
All Materials	Further information can be found in chapter <b>“4.1. Bürkert resistApp” on page 8</b>

<b>Medium temperature</b>	
With body material brass, stainless steel or PEEK	NBR: 32 °F...+ 176 °F EPDM: - 22 °F...+ 194 °F FKM: 32 °F...+ 194 °F FFKM: + 5 °F...+ 194 °F
With body material PP	NBR: 32 °F...+ 176 °F EPDM: - 22 °F...+ 176 °F FKM: 32 °F...+ 176 °F FFKM: + 41 °F...+ 176 °F
Viscosity	Max. 37 cSt

**Process/Port connection & communication**

<b>Electrical connection</b>	
Standard version	<ul style="list-style-type: none"> <li>Plug contacts according to DIN EN 175 301 -803 form A for cable plug <b>Type 2518</b> ▶ Further information can be found in chapter <b>“Cable plug Type 2518, form A according to DIN EN 175301 -803” on page 23.</b></li> <li>Plug contacts according to DIN EN 175 301 -803 form A for cable plug <b>Type 2509</b> ▶ (Also available with moulded cable on request.) Further information can be found in chapter <b>“Cable plug Type 2509, form A according to DIN EN 175301 -803” on page 23.</b></li> </ul>
Explosion-proof version	Moulded cable Terminal box without safety fuse (Information about ACP016 see operating manual.)
Port connection	G ¼, NPT ¼, (RC ¼ and G ½ on request, G ½ not possible for PP and PEEK)

**Approvals and conformities**

<b>Degree of protection</b>	
Standard version	IP65 with cable plug
Explosion-proof version	IP65
Explosion protection	Further information can be found in chapter <b>“3.4. Explosion protection” on page 6.</b>
North America (USA/Canada)	Further information can be found in chapter <b>“3.5. North America (USA/Canada)” on page 7.</b>
Others	Further information can be found in chapter <b>“3.6. Others” on page 7.</b>

**Environment and installation**

Installation position	As required, preferably with actuator upright
<b>Ambient temperature</b>	
Standard version	Max. + 131 °F
Explosion-proof version	Max. + 131 °F

1.) Measurement at +68 °F, 87 psi at the valve outlet, opening: pressure build-up 0...90 %, closing: pressure reduction 100...10 %

**2. Circuit functions**

Symbol	Description
	<b>Circuit function A (CF A)</b> 2/2-way solenoid valve Direct-acting Normally closed
	<b>Circuit function B (CF B)</b> 2/2-way solenoid valve Direct-acting Normally open
	<b>Circuit function C (CF C)</b> 3/2-way solenoid valve Direct-acting Normally closed

DTS 1000598012 EN Version: B Status: RL (released | freigegeben | valide) printed: 28.03.2024

Symbol	Description
	<b>Circuit function D (CF D)</b> 3/2-way solenoid valve Direct-acting Normally open
	<b>Circuit function E (CF E)</b> 3/2-way mixing valve (solenoid valve)
	<b>Circuit function F (CF F)</b> 3/2-way distribution valve (solenoid valve) Direct-acting
	<b>Circuit function T (CF T)</b> 3/2-way solenoid valve Direct-acting Flow direction optional Normally closed

### 3. Approvals and conformities

#### 3.1. General notes

- The approvals and conformities listed below must be stated when making enquiries. This is the only way to ensure that the product complies with all required specifications.
- Not all available versions can be supplied with the below mentioned approvals or conformities.

#### 3.2. Conformity

In accordance with the Declaration of Conformity, the product is compliant with the EU Directives.

#### 3.3. Standards

The applied standards which are used to demonstrate compliance with the EU Directives are listed in the EU-Type Examination Certificate and/or the EU Declaration of Conformity.

#### 3.4. Explosion protection

Approval	Description							
	<b>Optional: Explosion protection according to category 2 (zone 1/21)</b>  Ex marking of the components according to the following table:							
	<table border="1"> <thead> <tr> <th>Coil Type ACP016</th> <th>Coils with cable outlet</th> <th>Coils with terminal box</th> </tr> </thead> <tbody> <tr> <td><b>ATEX:</b> EPS 16 ATEX 1 111 X II 2 G Ex mb IIC T4 Gb II 2 D Ex mb IIIC T130 °C Db</td> <td><b>ATEX:</b> PTB 15 ATEX 1011 U II 2G Ex eb mb IIC T4 Gb II 2D EX mb tb IIIC T130 °C</td> </tr> <tr> <td><b>IECEx:</b> IECEx EPS 16.0049X Ex mb IIC T4 Gb Ex mb IIIC T130 °C Db</td> <td><b>IECEx:</b> IECEx PTB 15.0037 U II eb mb IIC T4 Gb II mb tb IIIC T130 °C Db</td> </tr> </tbody> </table>	Coil Type ACP016	Coils with cable outlet	Coils with terminal box	<b>ATEX:</b> EPS 16 ATEX 1 111 X II 2 G Ex mb IIC T4 Gb II 2 D Ex mb IIIC T130 °C Db	<b>ATEX:</b> PTB 15 ATEX 1011 U II 2G Ex eb mb IIC T4 Gb II 2D EX mb tb IIIC T130 °C	<b>IECEx:</b> IECEx EPS 16.0049X Ex mb IIC T4 Gb Ex mb IIIC T130 °C Db	<b>IECEx:</b> IECEx PTB 15.0037 U II eb mb IIC T4 Gb II mb tb IIIC T130 °C Db
Coil Type ACP016	Coils with cable outlet	Coils with terminal box						
<b>ATEX:</b> EPS 16 ATEX 1 111 X II 2 G Ex mb IIC T4 Gb II 2 D Ex mb IIIC T130 °C Db	<b>ATEX:</b> PTB 15 ATEX 1011 U II 2G Ex eb mb IIC T4 Gb II 2D EX mb tb IIIC T130 °C							
<b>IECEx:</b> IECEx EPS 16.0049X Ex mb IIC T4 Gb Ex mb IIIC T130 °C Db	<b>IECEx:</b> IECEx PTB 15.0037 U II eb mb IIC T4 Gb II mb tb IIIC T130 °C Db							

DTS 1000598012 EN Version: B Status: RL (released | freigegeben | validé) printed: 28.03.2024

3.5. North America (USA/Canada)

Approval	Description
	<p><b>Optional (valid for valves): UL Listed for the USA</b>                      The valves are UL Listed for the USA according to:</p> <ul style="list-style-type: none"> <li>UL 429 (electrically operated valves) and UL 429A (Electrically Operated Valves for Fire Protection Service)</li> </ul>
	<p><b>Optional (valid for coils): UL Hazardous Locations – Explosion Protection</b>                      UL Listed for Hazardous Locations for USA and Canada                      Class I, Zone 1                      Class I, Division 2, Group A, B, C and D                      Class II + III, Division 2, Group F and G</p>
	<p><b>Optional (valid for valves): UL Recognized for the USA</b>                      The valves are UL Recognized for the USA according to:</p> <ul style="list-style-type: none"> <li>UL 429 (electrically operated valves) and UL 429A (Electrically Operated Valves for Fire Protection Service)</li> </ul>
	<p><b>Optional (valid for valves): CSA for Canada</b>                      The valves are CSA approved for Canada according to:</p> <ul style="list-style-type: none"> <li>CSA 139 (electrically operated valves)</li> </ul>
	<p><b>Optional (valid for coils): FM (Factory Mutual) – Explosion Protection</b>                      FM for Hazardous Locations for USA and Canada                      Class I, Zone 1                      Class I, Division 1, Groups A, B, C and D                      Class II + III, Division 1, Groups E, F and G</p>

3.6. Others

DNV GL classification

Approval	Description
	<p><b>DNV GL classification – Ships, offshore units, and high speed and light craft</b>                      The products are accepted for installation on all vessels classed by DNV GL.</p>

DTS 1000598012 EN Version: B Status: RL (released | freigegeben | validé) printed: 28.03.2024

## 4. Materials

### 4.1. Bürkert resistApp



#### Bürkert resistApp – Chemical resistance chart

You want to ensure the reliability and durability of the materials in your individual application case? Verify your combination of media and materials on our website or in our resistApp.

[Start chemical resistance check](#)

### 4.2. Material specifications

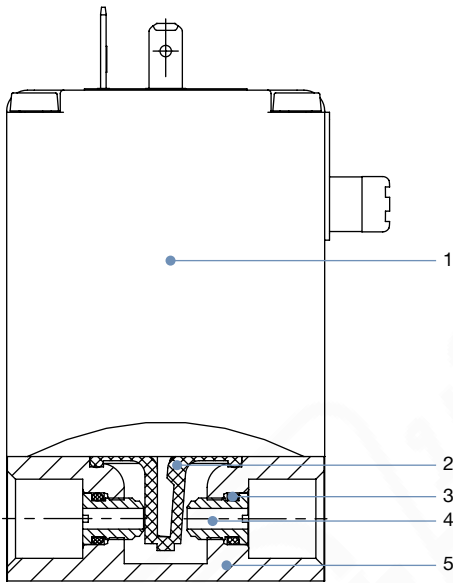

No.	Element	Material
1	Coil	Epoxy
2	Diaphragm	EPDM, FKM, FFKM, NBR
3	O-ring	EPDM, FKM, FFKM, NBR
4	Seat	Brass Stainless steel (1.4401/316) PP (Polypropylene) PEEK
5	Valve body	Brass Stainless steel (1.4401/316) PP (Polypropylene) PEEK



## 5. Dimensions

### 5.1. Standard version

**General notes:**

- The dimensions D1 and L1 apply to G-threads.
- The dimensions D2 and L2 apply to NPT-threads.
- The device can be attached via the existing holes on the bottom side. The hole pattern is 38x24/1.5x0.94. For metal bodies, use M4 screws. For plastic bodies, use either self-tapping screws or a body with metric thread inserts (variable codes ACxx or ADxx). The screw-in depth must be observed. Refer to **operating instructions Type 0330**.
- The dimensions of the cable plug Type 2518 can be found in chapter **“Cable plug Type 2518, form A according to DIN EN 175301 - 803” on page 23**.
- The dimensions of the cable plug Type 2509 can be found in chapter **“Cable plug Type 2509, form A according to DIN EN 175301 - 803” on page 23**.

**Metal body**

**Note:**

- Dimensions in mm [inch]
- For metal bodies, the minimum thread length at the middle connection is 7.5 mm [0.295 inch].
- Screw-in depth of G ¼ connection threads: When using pipe fittings, select versions with G ½, as the screw-in depth with G ¼ is not sufficient.
- See the general notes at the beginning of chapter **“5.1. Standard version” on page 9**.

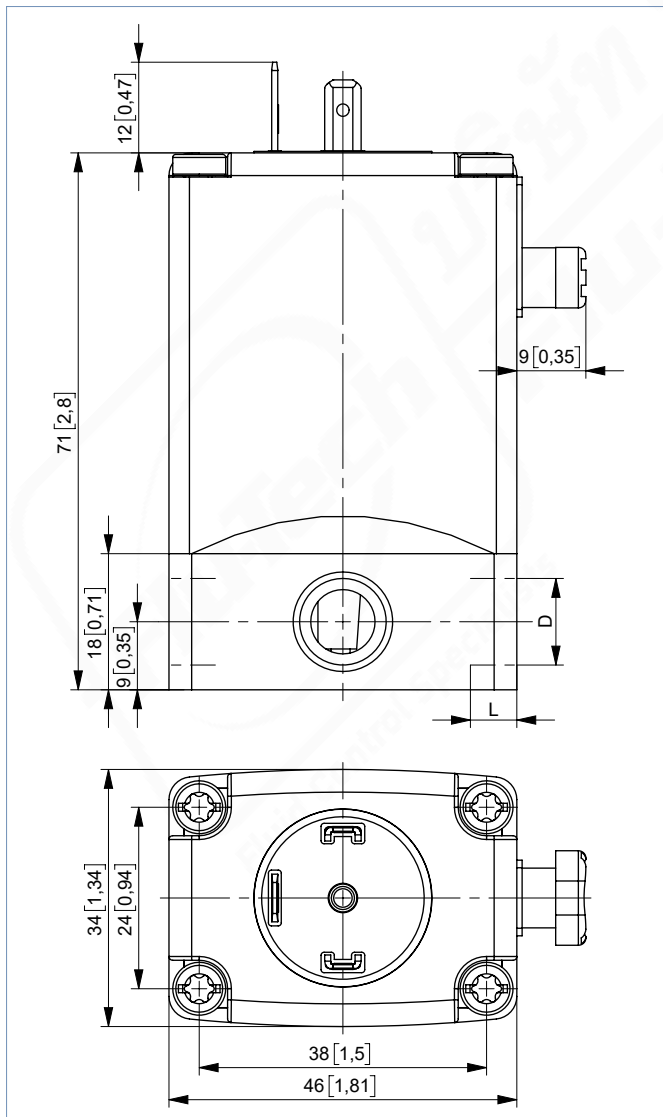

D1	L1		D2	L2	
	[mm]	[inch]		[mm]	[inch]
G ½	9	0.354	–	–	–
G ¼	9	0.354	NPT ¼	7.5	0.295

Plastic body

Note:

- Dimensions in mm [inch]
- See the general notes at the beginning of chapter "5.1. Standard version" on page 9.

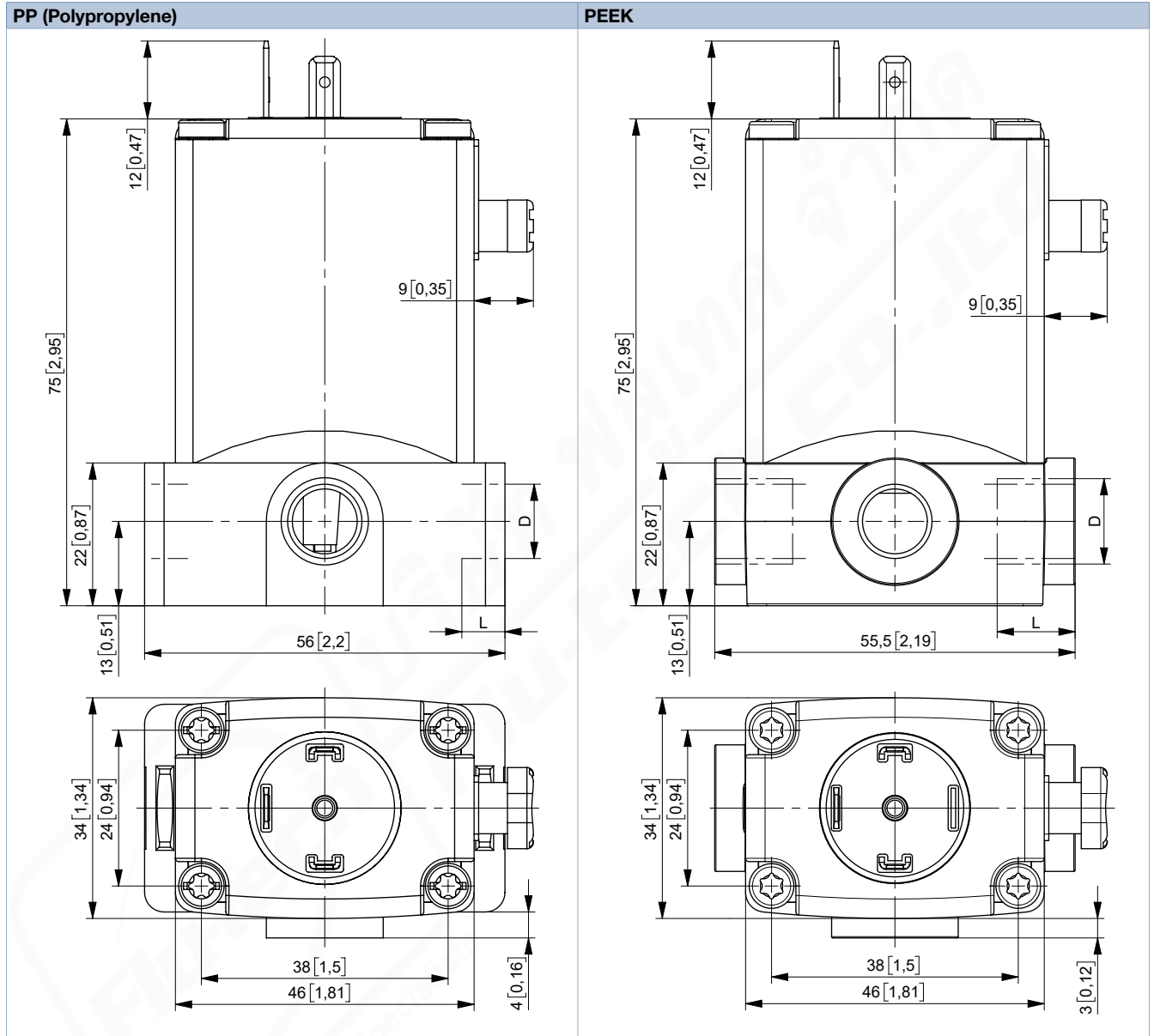

DTS 1000598012 EN Version: B Status: RL (released | freigegeben | validé) printed: 28.03.2024

**Cable version**

**Note:**

- Dimensions in mm [inch]
- See the general notes at the beginning of chapter “5.1. Standard version” on page 9.

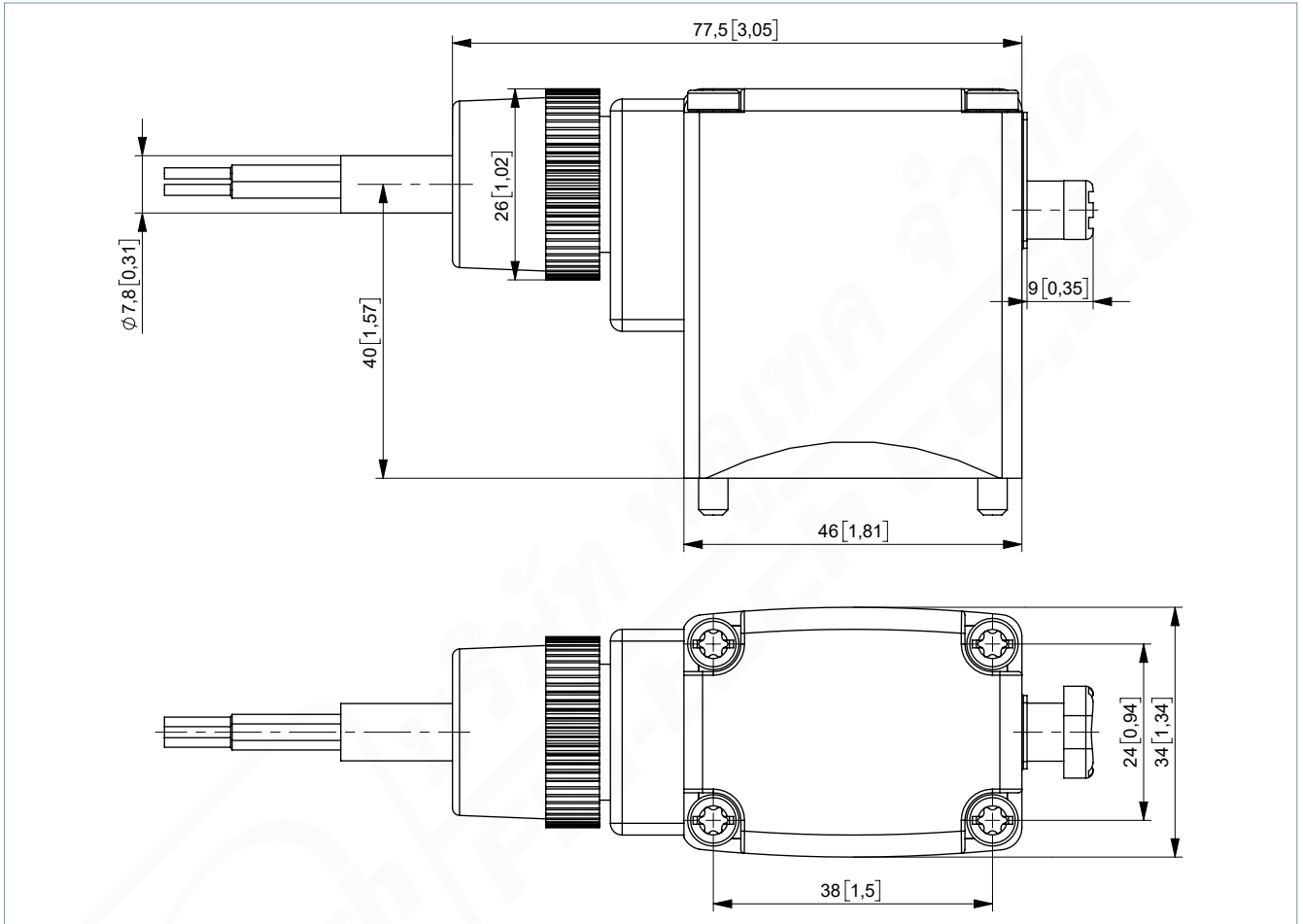

DTS 1000598012 EN Version: B Status: RL (released | freigegeben | valide) printed: 28.03.2024

### 5.2. Explosion-proof version

#### Terminal box version

**Note:**

- Dimensions in mm [inch]
- The dimensions D1 and L1 apply to G-threads.
- The dimensions D2 and L2 apply to NPT-threads.

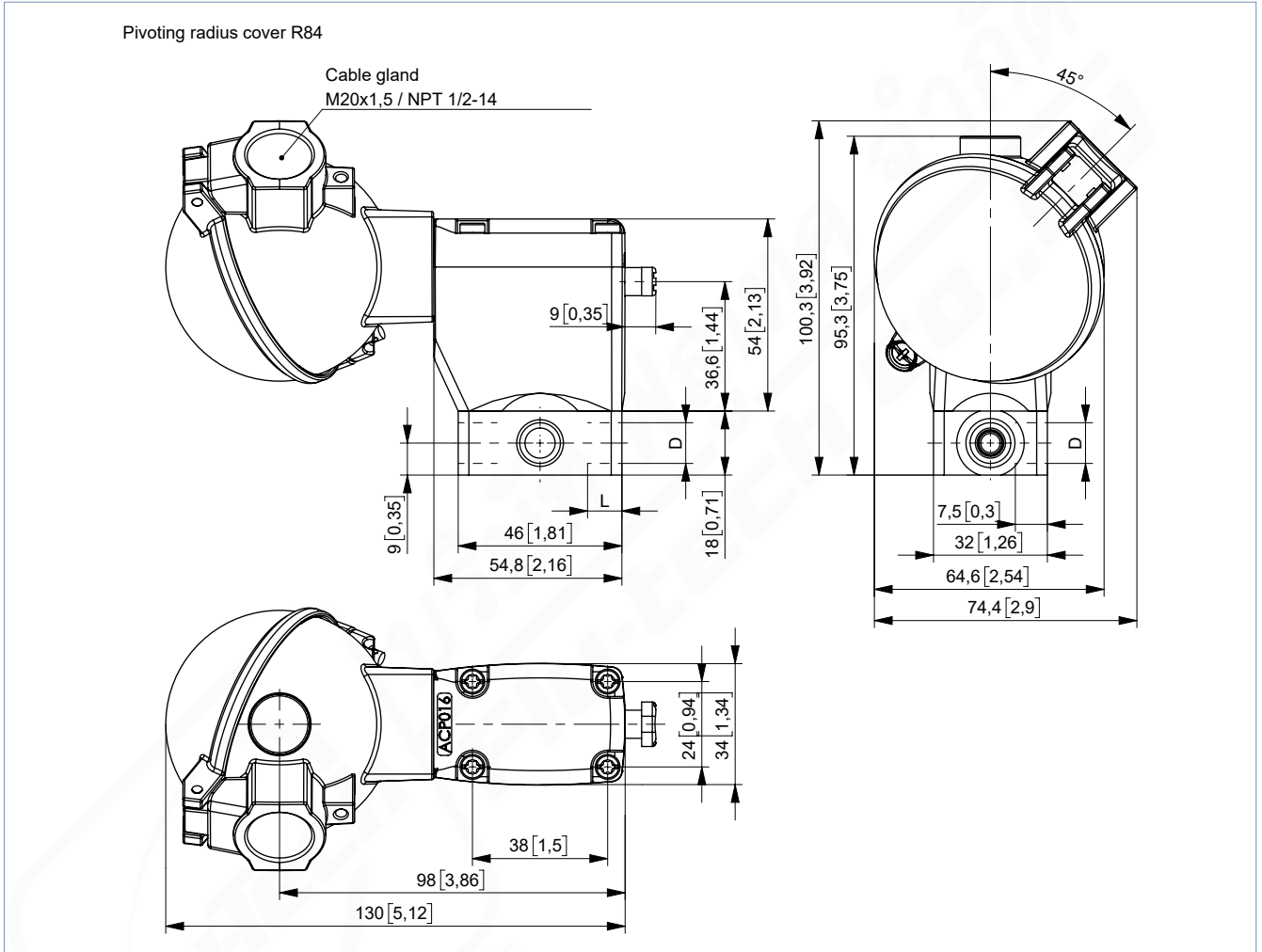

D1	L1		D2	L2	
	[mm]	[inch]		[mm]	[inch]
G 1/8	9	0.354	-	-	-
G 1/4	9	0.354	NPT 1/4	7.5	0.295

DTS 1000598012 EN Version: B Status: RL (released | freigegeben | validé) printed: 28.03.2024

**Cable version**

**Note:**

Dimensions in mm [inch]

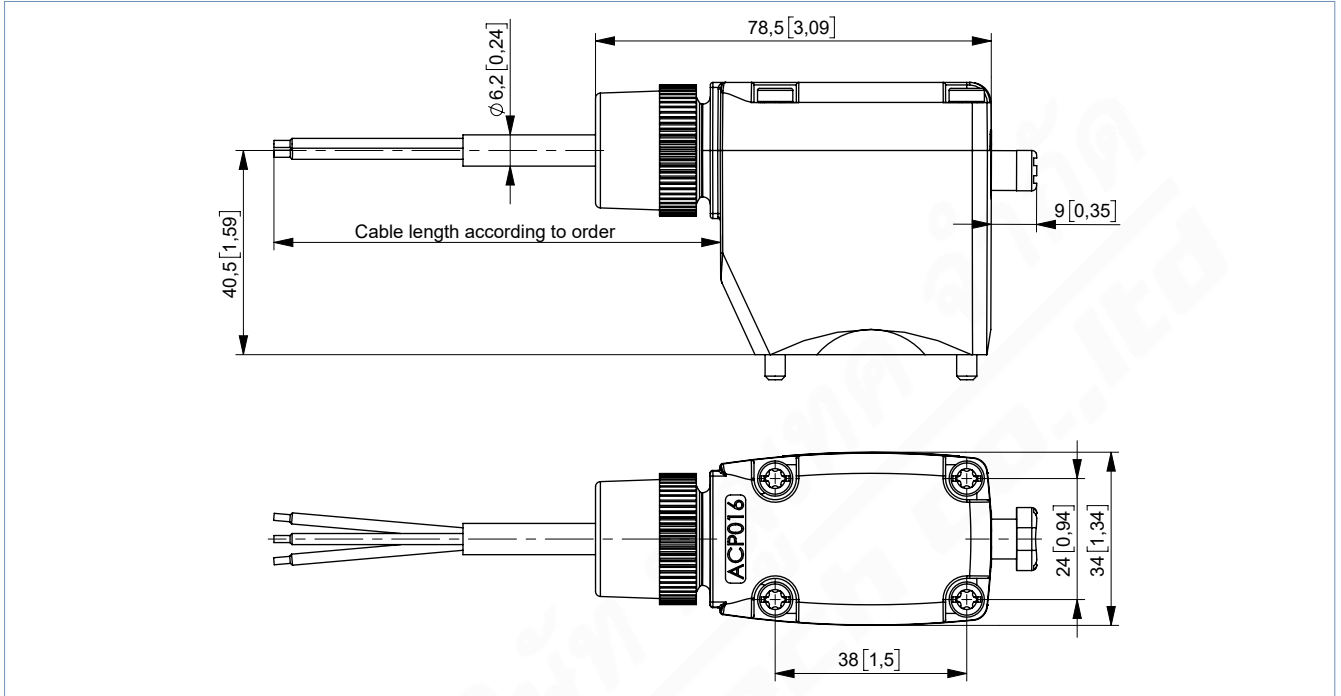

## 6. Device/Process connections

### 6.1. Pin assignment standard version

**Note:**

The pin assignment (marked No. 1, 2 and 3 in the drawing) depends on the circuit function. In the table, compare the respective pin assignment with the corresponding circuit function.

Circuit function	Connection 1	Connection 2	Connection 3	2-way	3-way
A	P	A	–		
B	B	P	–		
C	P	A	R		
D	R	B	P		
E	P1	A	P2		
F	A	P	B		
T	NC	I <sub>N</sub> /OUT	NO		

### 6.2. Pin assignment explosion-proof version

**Note:**

The pin assignment (marked No. 1, 2 and 3 in the drawing) depends on the circuit function. In the table, compare the respective pin assignment with the corresponding circuit function.

Circuit function	Connection 1	Connection 2	Connection 3	2-way	3-way
A	P	A	–		
B	B	P	–		
C	P	A	R		
D	R	B	P		
E	P1	A	P2		
F	A	P	B		
T	NC	I <sub>N</sub> /OUT	NO		

DTS 1000598012 EN Version: B Status: RL (released | freigegeben | validé) printed: 28.03.2024

## 7. Performance specifications

### 7.1. Pressure range and flow rate

#### Standard version

**Note:**

Refer to **“Use in other circuit functions”** on page 16 for more information about use in other circuit function.

Circuit function	DN	C <sub>v</sub> value water <sup>1.)</sup>		Pressure range <sup>2.)</sup> (MWAP <sup>9.)</sup>		
		DC	AC (50 or 60 Hz)	Standard <sup>3.)</sup>	Vacuum <sup>4.)</sup>	Impulse <sup>5.)</sup>
		[gal/min]	[gal/min]	[psi]	[psi]	[psi]
<b>Metal body</b>						
A / B / C / D / F	2	0.09	0.13	0...232 <sup>6.)</sup>	-14...145	0...232 <sup>6.)</sup>
	3	0.16	0.21	0...145	-14...87	0...145
	4	0.20	0.27	0...73	-14...44	0...73
	5	0.34	0.34	0...36	-14...15	0...36
E	2	0.09	0.13	0...145	-14...116	0...145
	3	0.16	0.21	0...87	-14...73	0...87
	4	0.20	0.27	0...44	-14...36	0...44
	5	0.34	0.34	0...22	-14...15	0...15
T	2	0.09	0.13	0...174	-14...116	0...145
	3	0.16	0.21	0...116	-14...73	0...87
	4	0.20	0.27	0...58	-14...36	0...73
	5	0.34	0.34	0...36	-14...15	-

Circuit function	DN	C <sub>v</sub> value water <sup>7.)</sup>	Pressure range <sup>2.)</sup> (MWAP <sup>9.)</sup>			
			Standard <sup>3.)</sup> AC [50 or 60 Hz]	Standard <sup>3.)</sup> DC	Vacuum <sup>4.)</sup>	Impulse <sup>5.)</sup>
		[gal/min]	[psi]	[psi]	[psi]	[psi]
<b>Plastic body</b>						
A / B / C / D / F	2	0.15	0...232 <sup>6.)8.)</sup>	0...174 <sup>8.)</sup>	-14...145	0...174 <sup>8.)</sup>
	3	0.29	0...145	0...116	-14...87	0...116
	4	0.35	0...73	0...58	-14...44	0...58
	5	0.46	0...65	0...44	-14...15	0...44
E / T	2	0.15	0...145	0...101	-14...101	0...101
	3	0.29	0...87	0...58	-14...73	0...58
	4	0.35	0...44	0...29	-14...36	0...29
	5	0.46	0...29	0...15	-14...7	0...15

- 1.) For frequency 56, the C<sub>v</sub> values of the DC version apply
- 2.) Pressure data: overpressure to atmospheric pressure (deviating pressure range for 5 W version)
- 3.) Heat output 8 W
- 4.) Vacuum possible for all seal materials
- 5.) Starting power 11 W
- 6.) The maximum medium pressure is 174 psi for seal material FKM and FFKM.
- 7.) The C<sub>v</sub> value at DC frequency is reduced by up to 10% to guarantee the function.
- 8.) The maximum operating pressure is 145 psi for industry material PVDF.
- 9.) Maximum allowable working pressure

DTS 1000598012 EN Version: B Status: RL (released | freigegeben | validé) printed: 28.03.2024

**Explosion-proof version**

**Note:**

Refer to “Use in other circuit functions” on page 16 for more information about use in other circuit function.

Circuit function	DN	C <sub>v</sub> value water [gal/min]	Pressure range <sup>1)2)</sup> (MAWP <sup>4)</sup> )	
			Standard [psi]	Vacuum [psi]
<b>Metal body</b>				
A / B / C / D / F	2.0	0.13	0...232	-14...145
	3.0	0.21	0...145	-14...87
	4.0	0.27	0...73	-14...44
	5.0	0.34	0...58	-14...36
E	2.0	0.15	0...145	-14...116
	3.0	0.21	0...87	-14...73
	4.0	0.27	0...51	-14...36
	5.0	0.34	0...44	-14...29
T	2.0	0.15	0...145	-14...116
	3.0	0.21	0...87	-14...73

Circuit function	DN	C <sub>v</sub> value water [gal/min]	Pressure range <sup>1)2)</sup> (MAWP <sup>4)</sup> )	
			Standard [psi]	Vacuum [psi]
<b>Plastic body</b>				
A / B / C / D / F	2.0	0.15	0...232 <sup>3)</sup>	-14...145
	3.0	0.29	0...145	-14...87
	4.0	0.35	0...73	-14...44
	5.0	0.46	0...65	-14...15
E / T	2.0	0.15	0...145	-14...101
	3.0	0.29	0...87	-14...73
	4.0	0.35	0...44	-14...36

- 1.) Devices with FKM and/or FFKM diaphragms are reduced to a maximum pressure of 174 psi.
- 2.) Pressure data: overpressure to atmospheric pressure
- 3.) The maximum operating pressure is 145 psi. for industry material PVDF.
- 4.) Maximum allowable working pressure

**Use in other circuit functions**

The compression springs installed in the valves differ depending on the circuit function. When used in other circuit functions, the permissible operating pressure changes according to the following table.

**Note:**

The following table applies to both the standard version and the explosion-proof version.

Circuit function	Max. operating pressure [psi] when using the valve in a new circuit function																	
	Orifice DN 2						Orifice DN 3						Orifice DN 4					
	A <sup>1.)</sup>	B <sup>1.)</sup>	C	D	E	F	A	B	C	D	E	F	A	B	C	D	E	F
<b>Metal body (8 W respectively 11 W)</b>																		
C	232	22	232	22	22	232	145	15	145	15	15	145	72.5	12	72.5	12	12	72.5
D	58	232	65	232	58	58	36	145	36	145	29	44	29	73	29	73	29	29
T	116	116	145	145	145	116	87	87	87	87	87	87	44	44	44	44	44	44
<b>Plastic body (8 W respectively 11 W)</b>																		
C	232	22	232	22	22	232	145	15	145	15	15	145	72.5	12	72.5	12	12	72.5
D	58	232	65	232	58	458	36	145	36	145	29	44	29	72.5	29	73	29	29
F	232	22	145	22	22	232	87	15	87	15	15	145	58	15	58	15	15	72.5

1.) For circuit function A and B the valve must be connected according to the pin assignment of 3/2-way valve.

DTS 1000598012 EN Version: B Status: RL (released | freigegeben | validé) printed: 28.03.2024



## 8. Product accessories

### 8.1. Accessories standard version

Option	Variable Code	Description
Impulse version	CF02	Bistable magnetic system with inrush and drop-off coil; continuous operation or operation with short current pulses (min. 150 ms) possible
Oxygen versions	NL02	Suitable for applications with oxygen (non-metal materials that are in contact with the medium, are tested and approved according to BAM)
Increased purity requirements, e.g. oil, grease and silicone-free	NL50/ NL05	Wetted parts are specially cleaned and packaged in accordance with the valves
Increased tightness requirements	PCxx	Standard units are tested at 10 <sup>-2</sup> mbar x l/sec; feasible up to 10 <sup>-6</sup> mbar
Electrical feedback	LF02/ LF03	See <b>Type 1060</b> ▶. Function as opener, closer or toggle switch depending on the connection (no IP65 achievable)
High-power electronics	CZ05	Inrush power 60 W, nominal holding current 3 W; with plastic versions 100 % duty cycle is now feasible
Vacuum version	NA02	Suitable for vacuums up to - 14 psi
Increased purity and tightness requirements	NA03	Wetted parts are specially cleaned and leak tested to 10 <sup>-4</sup> mbar x l/sec
Increased purity and tightness requirements and vacuum version	NA01	Wetted parts are specially cleaned and leak tested up to 10 <sup>-4</sup> mbar x l/sec and suited for vacuum up to - 14 psi
Coil with reduced power (5 W)	-	Devices have lower pressure range; with plastic versions 100 % duty cycle is now feasible
Cable plug	JHxx/ JGxx/ JFxx	Cable plug is part of the delivery. Cable plug versions (according to DIN EN 175301 - 803 form A), see data sheet <b>Type 2518</b> ▶ and <b>Type 2509</b> ▶
Approvals	PD01	CSA General Purpose valve
	PD02	UR (UL Recognized)/CSA approval
	PD07	DNV-GL (formerly Germanischer Lloyd)
	PR05	cFMus approved coil Class I, Division 1, Groups A, B, C and D - T4 Class II, Division 1, Groups E, F and G - T4 Class III, Division 1 - T4 Class I, Zone 1, AEx mb IIC T4 Gb, Zone 21 AEx mb IIIC T130 °C Db Ex mb IIC T4 Gb; Ex mb IIIC T130 °C Db
	PE95	UL (UL Listed) approval
	PU15	UL Listed for Hazardous Locations for USA and Canada, Class I, Zone 1, AEx eb mb IIC T4; Zone 21, AEx mb tb IIIC T130 °C / Class I, Div 2, Group A,B,C,D; Class II+III, Div 2, Group F,G
Possible conformities (depending on the assembly)	-	EAC, drinking water, FDA

### 8.2. Accessories explosion-proof version



Option	Variable Code	Description
Oxygen versions	NL02	Suitable for applications with oxygen (non-metal materials that are in contact with the medium, are tested and approved according to BAM)
Increased purity requirements e.g. oil, grease and silicone-free	NL50/ NL05	Wetted parts are specially cleaned and packaged in accordance with the valves
Increased hermetic requirements	PCxx	Standard units are tested at 10 <sup>-2</sup> mbar x l / sec; feasible up to 10 <sup>-6</sup> mbar
Vacuum version	NA02	Suitable for vacuums up to - 14 bar
Increased purity and hermetic requirements	NA03	Wetted parts are specially cleaned and leak tested to 10 <sup>-4</sup> mbar x l/sec
Increased purity and hermetic requirements and vacuum version	NA01	Wetted parts are specially cleaned and leak tested up to 10 <sup>-4</sup> mbar x l/sec and suited for vacuum up to - 14 bar
Electrical feedback	CF15	Coil with intrinsically safe proximity switches (PTB 00 ATEX 2048X) instead of manual override

DTS 1000598012 EN Version: B Status: RL (released | freigegeben | validé) printed: 28.03.2024

### 8.3. Cable glands for ATEX/IECEX terminal box

**Note:**

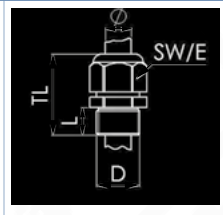
A polyamide cable gland is included in the scope of delivery. A nickel-plated brass version can be ordered for a surcharge, see [“Cable plug Type 2509, form A according to DIN EN 175301 - 803” on page 23.](#)

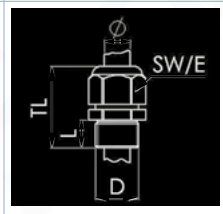
Description	Ex approvals		Dimensions										
	Certification	Identification											
Ex cable gland, Nickel-plated brass, 6...13 mm 	PTB 04 ATEX 1112 X, IECEX PTB 13.0027X	II 2 G Ex e IIC Gb, II 2 D Ex tb IIIC Db IP68	 <table border="1"> <tr><td>TL</td><td>29...37 mm</td></tr> <tr><td>L</td><td>6 mm</td></tr> <tr><td>D</td><td>20 mm</td></tr> <tr><td>SW</td><td>24 mm</td></tr> <tr><td>E</td><td>27 mm</td></tr> </table>	TL	29...37 mm	L	6 mm	D	20 mm	SW	24 mm	E	27 mm
TL	29...37 mm												
L	6 mm												
D	20 mm												
SW	24 mm												
E	27 mm												
Ex cable gland, Polyamide, 7...13 mm 	PTB 13 ATEX 1015 X, IECEX PTB 13.0034X	II 2 G Ex e IIC Gb, II 2 D Ex tb IIIC Db IP68	 <table border="1"> <tr><td>TL</td><td>36...45 mm</td></tr> <tr><td>L</td><td>10 mm</td></tr> <tr><td>D</td><td>20 mm</td></tr> <tr><td>SW</td><td>24 mm</td></tr> <tr><td>E</td><td>28 mm</td></tr> </table>	TL	36...45 mm	L	10 mm	D	20 mm	SW	24 mm	E	28 mm
TL	36...45 mm												
L	10 mm												
D	20 mm												
SW	24 mm												
E	28 mm												

### 8.4. Special tool to turn the terminal box

**Note:**

This special tool is not supplied with the valve, see [“Cable glands for ATEX/IECEX terminal box” on page 23.](#)

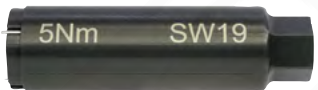
Description	Components of the set
Set SC02-AC10 	<ul style="list-style-type: none"> <li>• Special wrench</li> <li>• Service manual</li> </ul>

DTS 1000598012 EN Version: B Status: RL (released | freigegeben | validé) printed: 28.03.2024

## 9. Ordering information

### 9.1. Bürkert eShop



#### Bürkert eShop – Easy ordering and quick delivery

You want to find your desired Bürkert product or spare part quickly and order directly? Our online shop is available for you 24/7. Sign up and enjoy all the benefits.

[Order online now](#)

### 9.2. Bürkert product filter



#### Bürkert product filter – Get quickly to the right product

You want to select products comfortably based on your technical requirements? Use the Bürkert product filter and find suitable articles for your application quickly and easily.

[Try out our product filter](#)

### 9.3. Bürkert Product Enquiry Form

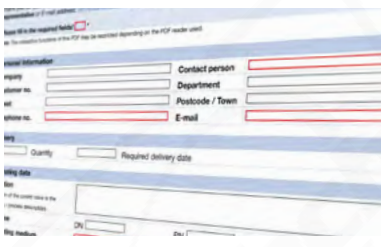

#### Bürkert Product Enquiry Form – Your enquiry quickly and compactly

Would you like to make a specific product enquiry based on your technical requirements? Use our Product Enquiry Form for this purpose. There you will find all the relevant information for your Bürkert contact. This will enable us to provide you with the best possible advice.

[Fill out the form now](#)

DTS 1000598012 EN Version: B Status: RL (released | freigegeben | validé) printed: 28.03.2024

### 9.4. Ordering chart

#### UL Recognized (UR) and CSA approval

**Note:**

- All devices with connection thread NPT ¼ and manual override.
- Other versions are available on request.
- Articles with reduced delivery time

Circuit function	Orifice [mm]	Body or seat material	Seal material	Article no.				
				024/DC [V/Hz]	024/60 [V/Hz]	120/60 [V/Hz]	240/60 [V/Hz]	
<b>CF A<sup>1)</sup></b> 2/2-way solenoid valve Direct-acting Normally closed 	2.0	PEEK	FKM	o. r.	o. r.	o. r.	o. r.	
			EPDM	o. r.	o. r.	o. r.	o. r.	
			FFKM	o. r.	o. r.	o. r.	o. r.	
	3.0	Brass	FKM	461284 ₺	468642 ₺	460216 ₺	o. r.	
			NBR	o. r.	o. r.	o. r.	o. r.	
		Stainless steel	FKM	459292 ₺	o. r.	459291 ₺	o. r.	
			PP	FKM	o. r.	o. r.	o. r.	o. r.
		PEEK	EPDM	o. r.	o. r.	o. r.	o. r.	
			FFKM	o. r.	o. r.	o. r.	o. r.	
			FFKM	o. r.	o. r.	o. r.	o. r.	
		4.0	Brass	FKM	464433 ₺	o. r.	464435 ₺	o. r.
				NBR	o. r.	o. r.	o. r.	o. r.
			Stainless steel	FKM	464432 ₺	o. r.	464434 ₺	o. r.
				PP	FKM	20004726 ₺	o. r.	o. r.
			PEEK	EPDM	o. r.	o. r.	o. r.	o. r.
	FFKM			o. r.	o. r.	o. r.	o. r.	
	5.0	PP	FKM	o. r.	o. r.	o. r.	o. r.	
			EPDM	20063459 ₺	o. r.	o. r.	o. r.	
	<b>CF B<sup>1)</sup></b> 2/2-way solenoid valve Direct-acting Normally open 	3.0	Brass	FKM	458947 ₺	458948 ₺	458949 ₺	458950 ₺
				Stainless steel	FKM	458959 ₺	o. r.	458961 ₺
4.0		Brass	FKM	458951 ₺	o. r.	o. r.	458954 ₺	
			Stainless steel	FKM	458963 ₺	458964 ₺	458965 ₺	o. r.
<b>CF C</b> 3/2-way solenoid valve Direct-acting Normally closed 	2.0	Brass	NBR	o. r.	o. r.	454359 ₺	465971 ₺	
			PEEK	FKM	o. r.	o. r.	o. r.	o. r.
				EPDM	o. r.	o. r.	o. r.	o. r.
				FFKM	o. r.	o. r.	o. r.	o. r.
	3.0	Brass	NBR	o. r.	o. r.	o. r.	o. r.	
			Stainless steel	FKM	451711 ₺	o. r.	450298 ₺	451715 ₺
		PEEK	FKM	o. r.	o. r.	o. r.	o. r.	
			EPDM	o. r.	o. r.	o. r.	o. r.	
			FFKM	o. r.	o. r.	o. r.	o. r.	
		4.0	Brass	NBR	o. r.	o. r.	o. r.	o. r.
	Stainless steel			FKM	466195 ₺	o. r.	451721 ₺	o. r.
	PP		FKM	o. r.	o. r.	o. r.	o. r.	
			EPDM	o. r.	o. r.	o. r.	o. r.	
	PEEK		FKM	o. r.	o. r.	o. r.	o. r.	
			FFKM	o. r.	o. r.	o. r.	o. r.	

DTS 1000598012 EN Version: B Status: RL (released | freigegeben | validé) printed: 28.03.2024

Circuit function	Orifice	Body or seat material	Seal material	Article no.			
				024/DC	024/60	120/60	240/60
	[mm]		[V/Hz]	[V/Hz]	[V/Hz]	[V/Hz]	
<b>CF D</b> 3/2-way solenoid valve Direct-acting Normally open 	2.0	Brass	NBR	o. r.	o. r.	o. r.	o. r.
	3.0	Brass	NBR	o. r.	o. r.	o. r.	o. r.
	4.0	Brass	NBR	o. r.	o. r.	o. r.	o. r.
<b>CF E</b> 3/2-way mixing valve (solenoid valve) 	3.0	PP	FKM	o. r.	o. r.	o. r.	o. r.
			EPDM	o. r.	o. r.	o. r.	o. r.
	4.0	PP	FKM	o. r.	o. r.	o. r.	o. r.
			EPDM	o. r.	o. r.	o. r.	o. r.
<b>CF F</b> 3/2-way distribution valve (solenoid valve) Direct-acting 	4.0	PP	FKM	o. r.	o. r.	o. r.	o. r.
			EPDM	o. r.	o. r.	o. r.	o. r.
<b>CF T</b> 3/2-way solenoid valve Direct-acting Flow direction optional Normally closed 	2.0	Brass	FKM	o. r.	o. r.	o. r.	o. r.
		Stainless steel	FKM	o. r.	o. r.	o. r.	o. r.
		PEEK	FKM	o. r.	o. r.	o. r.	o. r.
			EPDM	o. r.	o. r.	o. r.	o. r.
			FFKM	o. r.	o. r.	o. r.	o. r.
	3.0	Brass	FKM	o. r.	o. r.	o. r.	o. r.
		Stainless steel	FKM	o. r.	o. r.	o. r.	o. r.
		PEEK	FKM	o. r.	o. r.	o. r.	o. r.
			EPDM	o. r.	o. r.	o. r.	o. r.
			FFKM	o. r.	o. r.	o. r.	o. r.

o. r. = on request

1.) The listed article numbers and circuit functions have a body with straight pass.

DTS 1000598012 EN Version: B Status: RL (released | freigegeben | validé) printed: 28.03.2024

**Coil UL Listed (cULus) for hazardous locations, Class I, Division 2**

**Note:**

- All devices with connection thread NPT ¼ and manual override.
- Other versions are available on request.

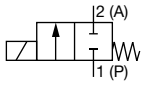
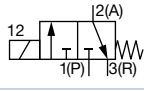
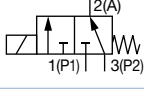
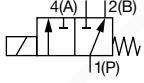
Circuit function	Orifice [mm]	Body or seat material	Seal material	Electrical connection	Article no.		
					024 / AC/DC [V/Hz]	120/60 [V/Hz]	240/60 [V/Hz]
<b>CF A</b> <sup>1.)</sup> 2/2-way solenoid valve Direct-acting Normally closed 	3.0	Brass	NBR	Terminal box	o. r.	o. r.	o. r.
		Stainless steel	FKM	Cable	o. r.	o. r.	o. r.
		Stainless steel	FKM	Terminal box	384939 ☞	20036806 ☞	o. r.
		Stainless steel	FKM	Cable	o. r.	o. r.	o. r.
<b>CF C</b> 3/2-way solenoid valve Direct-acting Normally closed 	3.0	Brass	NBR	Terminal box	o. r.	o. r.	o. r.
		Stainless steel	FKM	Cable	o. r.	o. r.	o. r.
		Stainless steel	FKM	Terminal box	o. r.	o. r.	o. r.
		Stainless steel	FKM	Cable	o. r.	o. r.	o. r.
<b>CF E</b> 3/2-way mixing valve (solenoid valve) 	3.0	Stainless steel	FKM	Terminal box	o. r.	o. r.	o. r.
				Cable	387628 ☞	o. r.	o. r.
<b>CF F</b> 3/2-way distribution valve (solenoid valve) Direct-acting 	3.0	Stainless steel	FKM	Terminal box	o. r.	o. r.	o. r.
	3.0	Stainless steel	FKM	Cable	o. r.	o. r.	o. r.
	4.0	Stainless steel	FKM	Terminal box	o. r.	o. r.	o. r.
	4.0	Stainless steel	FKM	Cable	o. r.	o. r.	o. r.

o. r. = on request

1.) The listed article numbers and circuit functions have a body with straight pass.

DTS 1000598012 EN Version: B Status: RL (released | freigegeben | validé) printed: 28.03.2024

### 9.5. Ordering chart accessories

#### Cable plug Type 2518, form A according to DIN EN 175301 - 803

**Note:**

- Dimensions in mm
- For further versions see data sheet **Type 2518** ▶

Cable plug	Dimensions	Version	Voltage	Article no.
		Without circuitry (AC/DC)	0...250 V AC/DC	314802
		With LED (AC/DC)	12...24 V AC/DC	314812
		With LED and varistor (AC/DC)	12...24 V AC/DC	314820
		With rectifier, LED and varistor	12...24 V AC/DC	314816
		Without circuitry (AC/DC) with silicone seal for higher ambient temperature, e.g. steam version (NA07)	0...250 V AC/DC	361687

#### Cable plug Type 2509, form A according to DIN EN 175301 - 803

**Note:**

- Dimensions in mm
- Without circuitry (standard)
- Refer to data sheet **Type 2509** ▶ for more information about the cable plug.

Cable plug	Dimensions	Version	Voltage	Article no.
		Without circuitry	0...250 V AC/DC	137943

#### Cable glands for ATEX/IECEX terminal box

**Note:**

- A cable gland in polyamide version is included in the delivery. A nickel-plated brass version can be ordered at surcharge.
- Refer to **“8.3. Cable glands for ATEX/IECEX terminal box”** on page 18 for more information about Ex cable glands.
- Refer to **“8.4. Special tool to turn the terminal box”** on page 18 for more information about special wrench.

Description	Article no.
Ex cable gland, nickel-plated brass, 6...13 mm <sup>1)</sup>	773278
Ex cable gland, polyamide, 7...13 mm <sup>1)</sup>	773277
Set SC02-AC10: special wrench <sup>2)</sup> incl. service manual	293488

1.) Cable diameter

2.) Not included in the scope of delivery of the valve

**Mounting plate complete for DIN rail mounting**

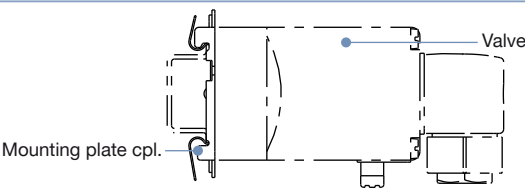
Description	Article no.
	<p>013253 𠄎</p>

**Locking ring**

Description	Article no.
<p>Locking ring to prevent inadvertent manual actuation</p> 	<p>013372 𠄎</p>

DTS 1000598012 EN Version: B Status: RL (released | freigegeben | valide) printed: 28.03.2024

