

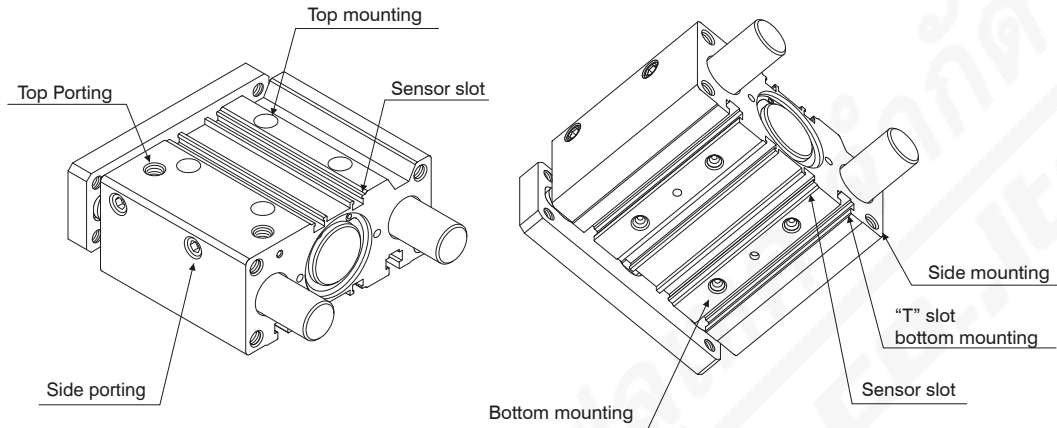

## Series 6100 - 6101 - 6110 - Guided compact cylinder



3

PNEUMATIC ACTUATION

These guided compact cylinders, characterised by reduced overall dimensions, can be used for the compression, conveyance and manipulation of objects in many industrial sectors; similarly they can also be used in pushing, lifting and stopping applications.

These cylinders are available in sizes 32mm to 63 mm diameter, and comprise a single compact cylinder with integral guide rods, making it a true guide cylinder designed with installation flexibility and space saving in mind.

The rod guide is available in two styles:

**Self-lubricating bronze bushes** - useful for absorbing lateral loads and forces, especially as a stopper.

**Bearing bushes** - guaranteeing high precision and uniform movement with low friction characteristics, useful with mis-aligned loads.

Guided compact cylinders are ideal for use in applications requiring a combination of reduced dimensions and anti-rotation features. Mounting can be achieved on three sides through holes or "T" slots.

Adjustable mounting holes in the front plate ensure safe and accurate assembly. Pneumatic connections can be made to either lateral or top ports (lateral ports plugged on standard units).

When sensors are required, there are special slots in the barrel extrusion where 1580 series miniaturised sensors are easily fitted.

**FLU-TECH CO. LTD.**

**Email:** sales@flutech.co.th **Website:** <https://flutech.co.th>

**Tel:** 02-384-6060, 086-369-5871-3 **Fax:** 02-384-5701 **LINE OA:** @flutech.co.th

**Address (HQ):** 845/3-4, Moo 3, Theparak Rd., T. Theparak, A. Mueang Samut Prakan, Samut Prakan, 10270, Thailand

LINE OA WEBSITE



► Guided compact cylinder



Ordering code

**6100.Ø.stroke.**

12	}	Side supply ports closed
16		
20	}	L = Top supply ports closed
25		
32	}	B = Control unit with bronze bush
40		
50	}	C = Control unit with bearing bush
63		

Construction characteristics

Body	anodised aluminium
Guide rods	C43 chromed steel (control unit with bronze bush) tempered and chromed steel (control unit with bearing bush)
Piston	aluminium
Piston rod	stainless steel (for bores Ø12, Ø16, Ø20, Ø25) C43 chromed steel (for bores Ø32, Ø40, Ø50, Ø63)
Rods bushing	bronze or bearing bushing
End cap	anodised aluminium
Piston seal	oil resistant NBR rubber
Piston rod seal	PUR (NBR 12-16)
Wipers	PUR
Plate	nickel plated steel

Operational characteristics

Function	double acting
Fluid	Filtered air. No lubrication needed, if applied it shall be continuous.
Working pressure	max. 10 bar
Working temperature	-5°C - +70°C
Cushioning	elastic bumper on both ends

Standard stroke

Bore	Stroke											
	10	20	25	30	40	50	75	100	125	150	175	200
Ø12	●	●		●	●	●	●	●				
Ø16	●	●		●	●	●	●	●				
Ø20		●		●	●	●	●	●	●	●	●	●
Ø25		●		●	●	●	●	●	●	●	●	●
Ø32			●			●	●	●	●	●	●	●
Ø40			●			●	●	●	●	●	●	●
Ø50			●			●	●	●	●	●	●	●
Ø63			●			●	●	●	●	●	●	●

Intermediate strokes can be obtained using spacers with defined length (5, 10, 15, 20 mm).

Example: It is possible to obtain a **6100.32.45.B** cylinder from a **6100.32.50.B** cylinder by inserting a spacer with length of 5 mm. The intermediate strokes manufactured without the use of spacers are considered special executions.

Overall dimensions

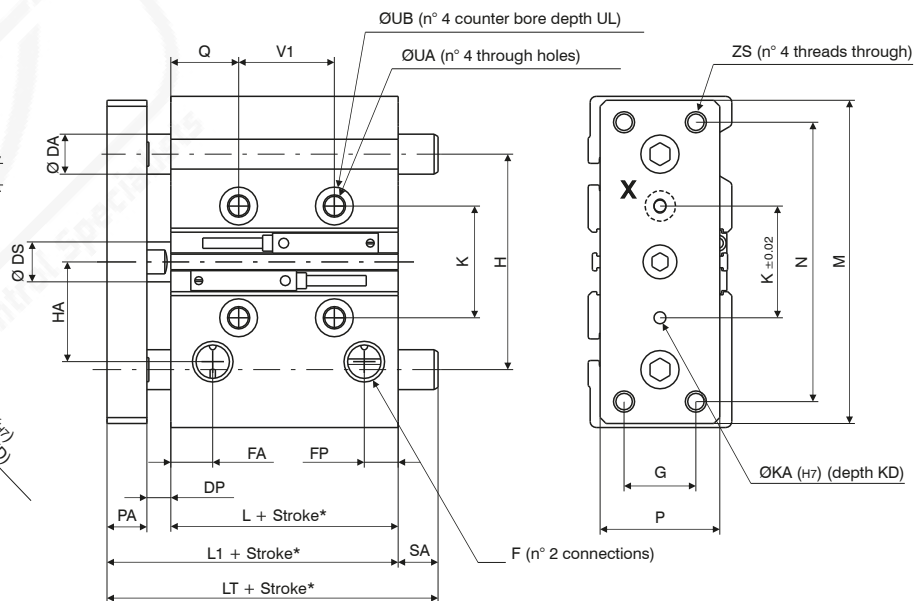
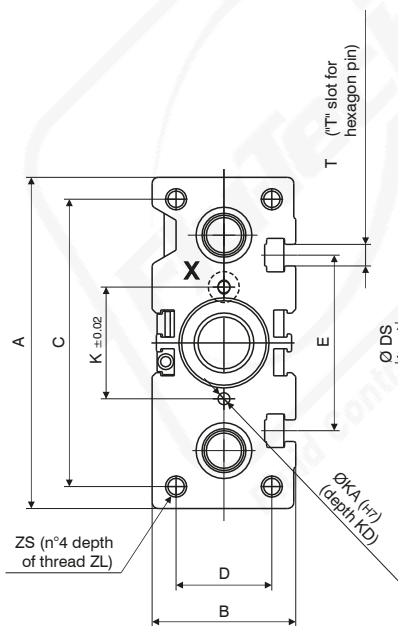
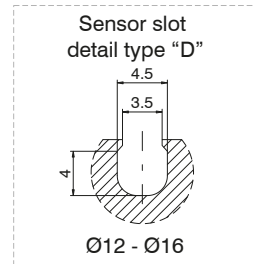
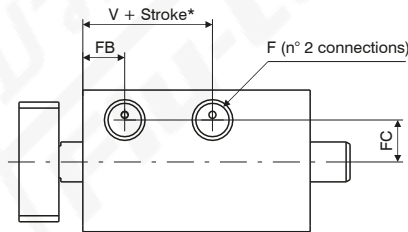
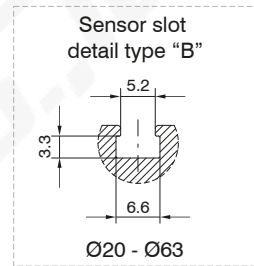
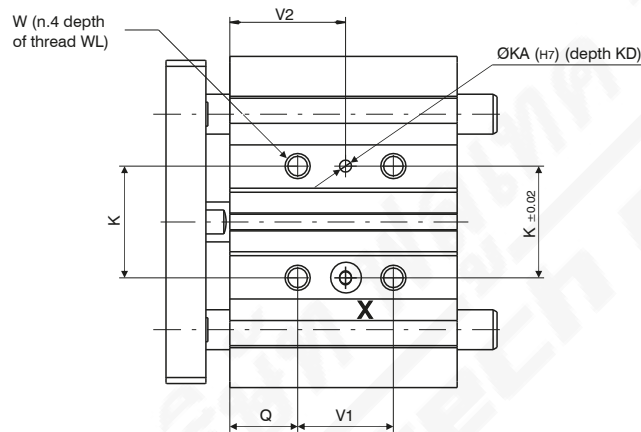
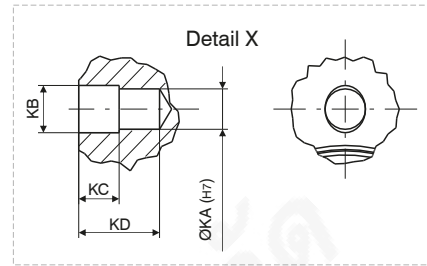
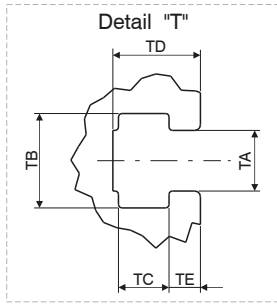

\*Dimensions only refer to the "standard stroke"



Overall dimensions

Bore	Ø12	Ø16	Ø20	Ø25	Ø32	Ø40	Ø50	Ø63
Table of dimensions								
A	58	64	83	93	112	120	148	162
B	26	30	36	42	48	54	64	78
C	40	42	72	82	98	106	130	142
D	18	22	24	30	34	40	46	58
Control unit with bronze bushes Control unit with bearing bushes	DA	8 6	10 8	12 10	16 14	20 16	25 20	25 20
	DP	2	2	5,5	5,5	9,5	10	13
DS	6	8	10	12	16	16	20	20
E	/	/	44	50	63	72	92	110
F	M5	M5	G1/8"	G1/8"	G1/8"	G1/8"	G1/4"	G1/4"
FA	11	11	11	12	13	13	13	14
FB	11	11	11	12	13	13	13	14
FC	8,5	10	10,5	13,5	15	18	21,5	28
FP	15	17	9	10,5	9,5	11	11	12,5
G	14	16	18	26	30	30	40	50
H	41,5	46	54	64	78	86	110	124
HA	19,5	23	25	28,5	34	38	47	55
K	23	24	28	34	42	50	66	80
KA	/	/	3	4	4	4	5	5
KB	/	/	3,5	4,5	4,5	4,5	6	6
KC	/	/	3	3	3	3	4	4
KD	/	/	6	6	6	6	8	8
L	29	31	38	38,5	38,5	44	44	49
Control unit with bronze bushes Control unit with bearing bushes	L1	39	43	53,5	54	60	66	72
	LT	39 57	43 64	53,5 84,5	54 85	97 102	97 102	106,5 118
See table 1								
M	56	62	81	91	110	118	146	158
N	48	52	70	78	96	104	130	130
PA	8	10	10	10	12	12	15	15
P	22	25	30	38	44	44	60	70
Q	5	5	17,5	17,5	21,5	22	24	24
Control unit with bronze bushes Control unit with bearing bushes	SA	/	/	/	/	37	31	34,5
		18	21	31	31	42	36	46
See table 1								
T	/	/	M5	M5	M6	M6	M8	M10
TA	/	/	5,4	5,4	6,5	6,5	8,5	11
TB	/	/	8,4	8,4	10,5	10,5	13,5	17,8
TC	/	/	4,5	4,5	5,5	5,5	7,5	10
TD	/	/	7,8	8,2	9,5	11	13,5	18,5
TE	/	/	2,8	3	3,5	4	4,5	7
UA	4,3	4,3	5,6	5,6	6,6	6,6	8,6	8,6
UB	8	8	9,5	9,5	11	11	14	14
UL	4,5	4,5	5,5	5,5	7,5	7,5	9	9
V	14	14	13	13	7,5	13	9	14
V1	See table 2							
V2	See table 2							
W	M5	M5	M6x1	M6x1	M8x1,25	M8x1,25	M10x1,5	M10x1,5
WL	10	10	12	12	16	16	20	20
Z	M4	M5	M5x0,8	M6x1	M8x1,25	M8x1,25	M10x1,5	M10x1,5
ZL	9	11	13	15	20	20	22	22

Control unit with bronze bushes	stroke	≤50
	50 < stroke	≤200

Control unit with bronze bushes	stroke	≤50
	50 < stroke	≤200

Control unit with bearing bushes	Table 1			Table 2		
	stroke ≤ 30	30 < stroke ≤ 100	100 < stroke ≤ 200	stroke < 50	50 ≤ stroke ≤ 100	100 < stroke ≤ 200
<b>Bore</b>						
Ø12	39	53	53	/	14	/
Ø16	43	64	64	/	21	/
Ø20	47	72	72	/	18,5	49
Ø25	49	77	77	/	23	48
Ø32	/	87	117	/	27	57
Ø40	/			/	21	51
Ø50	/	92	127	/	20	55
Ø63	/			/	15	50

Control unit with bearing bushes	Table 1			Table 2		
	stroke ≤ 30	30 < stroke ≤ 100	100 < stroke ≤ 200	stroke ≤ 25	25 < stroke ≤ 100	100 < stroke ≤ 200
<b>Bore</b>						
Ø12	4 + stroke			/	/	/
Ø16	4 + stroke			/	/	/
Ø20	24	44	120	29,5	39,5	77,5
Ø25	24	44	120	29,5	39,5	77,5
Ø32	24	48	124	33,5	45,5	83,5
Ø40	24	48	124	34	46	84
Ø50	24	48	124	36	48	86
Ø63	28	52	128	38	50	88



Weight - Cylinder force - kinetic energy

Stroke	Bore																
	Ø12		Ø16		Ø20		Ø25		Ø32		Ø40		Ø50		Ø63		
	<b>Control unit with bronze bushes</b>																<b>Weight g</b>
10	240		330		/		/		/		/		/		/		/
20	280		380		670		950		/		/		/		/		/
25	/		/		/		/		1690		1950		3360		4180		/
30	310		430		750		1050		/		/		/		/		/
40	350		480		830		1160		/		/		/		/		/
50	390		530		910		1270		2070		2370		4000		4940		/
75	500		680		1170		1650		2470		2830		4730		5780		/
100	5903		800		1370		1920		2850		3250		5370		6540		/
125	/		/		1570		2190		3240		3680		6010		7290		/
150	/		/		1760		2470		3620		4100		6650		8050		/
175	/		/		1960		2740		4000		4530		7290		8800		/
200	/		/		2160		3010		4380		4950		7930		9560		/
Stroke	<b>Moving parts</b>																
10	100		155		/		/		/		/		/		/		/
20	108		170		330		520		/		/		/		/		/
25	/		/		/		/		1070		1140		2150		2500		/
30	116		185		350		560		/		/		/		/		/
40	124		200		380		600		/		/		/		/		/
50	132		215		400		640		1230		1300		2400		2750		/
75	152		250		520		840		1420		1490		2750		3090		/
100	172		285		580		950		1580		1650		3000		3350		/
125	/		/		640		1050		1740		1810		3260		3600		/
150	/		/		700		1150		1910		1980		3510		3860		/
175	/		/		760		1250		2070		2140		3760		4110		/
200	/		/		820		1350		2230		2300		4020		4360		/
Stroke	<b>Control unit with bearing bushes</b>																
10	240		340		/		/		/		/		/		/		/
20	270		390		700		980		/		/		/		/		/
25	/		/		/		/		1540		1790		3110		3930		/
30	300		430		770		1070		/		/		/		/		/
40	350		510		890		1250		/		/		/		/		/
50	390		560		970		1340		1850		2150		3660		4590		/
75	470		670		1140		1570		2300		2640		4410		5460		/
100	560		790		1310		1810		2620		3000		4960		6120		/
125	/		/		1520		2080		2990		3420		5600		6880		/
150	/		/		1690		2310		3310		3780		6150		7540		/
175	/		/		1870		2540		3620		4140		6700		8210		/
200	/		/		2040		2770		3940		4500		7250		8870		/
Stroke	<b>Moving parts</b>																
10	95		145		/		/		/		/		/		/		/
20	100		153		310		490		/		/		/		/		/
25	/		/		/		/		820		890		1770		2110		/
30	105		161		330		520		/		/		/		/		/
40	110		169		370		580		/		/		/		/		/
50	120		177		390		610		940		1010		1950		2300		/
75	145		197		440		690		1110		1180		2240		2590		/
100	170		217		480		760		1230		1300		2430		2770		/
125	/		/		560		880		1410		1480		2710		3050		/
150	/		/		600		950		1530		1600		2890		3240		/
175	/		/		650		1020		1650		1720		3080		3420		/
200	/		/		700		1100		1770		1830		3270		3610		/
Working pressure	<b>Cylinder theoretic force (N)</b>																
2 bar	23	17	40	30	63	47	98	76	161	121	251	211	393	330	623	561	
3 bar	34	26	60	45	94	71	147	113	241	181	377	317	589	495	935	841	
4 bar	45	34	80	60	126	94	196	151	322	241	503	422	785	660	1247	1121	
5 bar	57	43	101	76	157	118	246	189	402	302	629	528	982	825	1559	1402	
6 bar	68	51	121	91	188	142	295	227	482	362	754	634	1178	989	1870	1682	
7 bar	79	60	141	106	220	165	344	265	563	422	880	739	1374	1154	2182	1962	
8 bar	90	68	161	121	251	189	393	302	643	482	1006	845	1570	1319	2494	2242	
9 bar	102	77	181	136	283	212	442	340	724	543	1131	950	1767	1484	2805	2523	
10 bar	113	85	201	151	314	236	491	378	804	603	1257	1056	1963	1649	3117	2803	
Piston area (mm <sup>2</sup> )	out	in	out	in	out	in	out	in	out	in	out	in	out	in	out	in	
	113	85	201	151	314	236	491	378	804	603	1257	1056	1963	1649	3117	2803	
	<b>Maximum permissible Momentum</b>																
J	0,08		0,09		0,11		0,18		0,29		0,52		0,91		1,54		

How to calculate the Momentum:  $E_c = \frac{1}{2} m V^2$  (J)

**m** = Total moving mass: weight of driven object added to weight of cylinder moving parts (kg)

**V** = max. speed: equal to average speed + 40% (m/sec)

Operating criteria

Permissible lateral load (applied on overall plate)

Version	Stroke	Bore							
		Ø12	Ø16	Ø20	Ø25	Ø32	Ø40	Ø50	Ø63
		<b>Permissible lateral load (N)*</b>							
Control unit with bronze bushes	10	30	48						
	20	23	37	49	69				
	25					203	203	296	296
	30	19	30	43	60				
	40	16	25	38	54				
	50	14	20	35	49	164	164	245	245
	75	12	18	87	116	182	182	273	273
	100	10	15	75	100	159	159	241	241
	125			66	88	142	142	216	216
	150			59	79	127	127	195	195
	175			54	71	116	116	179	179
	200			49	65	106	106	164	164
	Control unit with bearing bushes	10	20	35					
20		15	28	58	69				
25						191	190	208	206
30		13	22	48	68				
40		11	18	101	132				
50		10	16	90	118	157	157	173	171
75		8	14	70	93	164	163	223	221
100		6	11	58	77	144	144	199	196
125				62	80	203	203	264	262
150				54	70	186	185	242	240
175				48	62	171	171	224	221
200				43	55	158	158	207	205
		<b>Recommended torque moments (Nm)</b>							
Control unit with bronze bushes	10	0,40	0,70						
	20	0,35	0,65	1,1	1,8				
	25					6,4	7,0	13,0	14,7
	30	0,28	0,48	0,9	1,6				
	40	0,25	0,45	0,8	1,4				
	50	0,21	0,39	0,8	1,3	5,1	5,7	10,8	12,1
	75	0,42	0,68	1,9	3,0	5,7	6,3	12,0	13,5
	100	0,40	0,60	1,6	2,6	5,0	5,5	10,6	11,9
	125			1,4	2,3	4,4	4,9	9,5	10,7
	150			1,3	2,0	4,0	4,4	8,6	9,7
	175			1,2	1,8	3,6	4,0	7,9	8,9
	200			1,1	1,7	3,3	3,7	7,2	8,2
	Control unit with bearing bushes	10	0,62	0,70					
20		0,41	0,65	1,3	2,1				
25						6,0	6,6	9,2	10,2
30		0,33	0,48	1,0	1,8				
40		0,30	0,45	2,2	3,4				
50		0,48	0,39	1,9	3,0	4,9	5,4	7,6	8,5
75		0,38	0,68	1,5	2,4	5,1	5,6	9,8	11,0
100		0,32	0,60	1,3	2,0	4,5	5,0	8,7	9,7
125				1,3	2,1	6,3	7,0	11,6	13,0
150				1,2	1,8	5,8	6,4	10,7	11,9
175				1,0	1,6	5,3	5,9	9,8	11,0
200				0,9	1,4	4,9	5,4	9,1	10,2

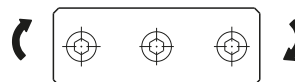
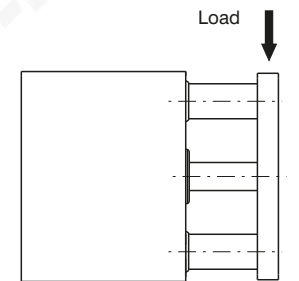
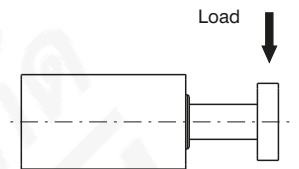

3  
PNEUMATIC ACTUATION

\*(Applied on overall plate)

Operating criteria

Stopper device applications

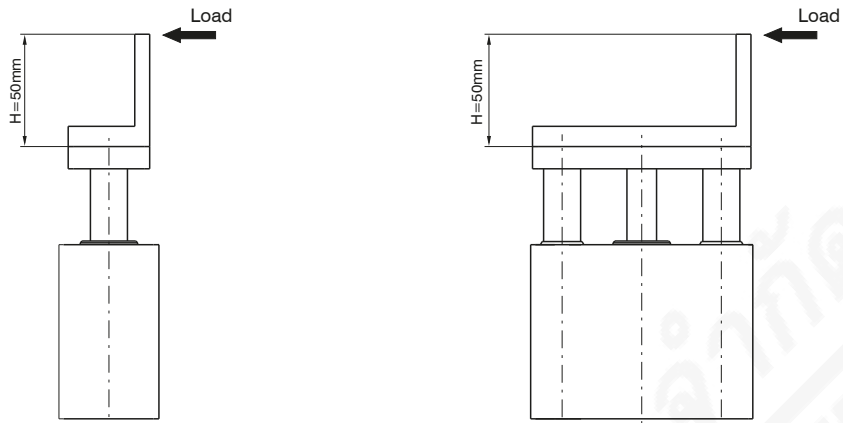

Control unit with  
bronze bushes

ATTENTION: if H>50 mm use larger bore

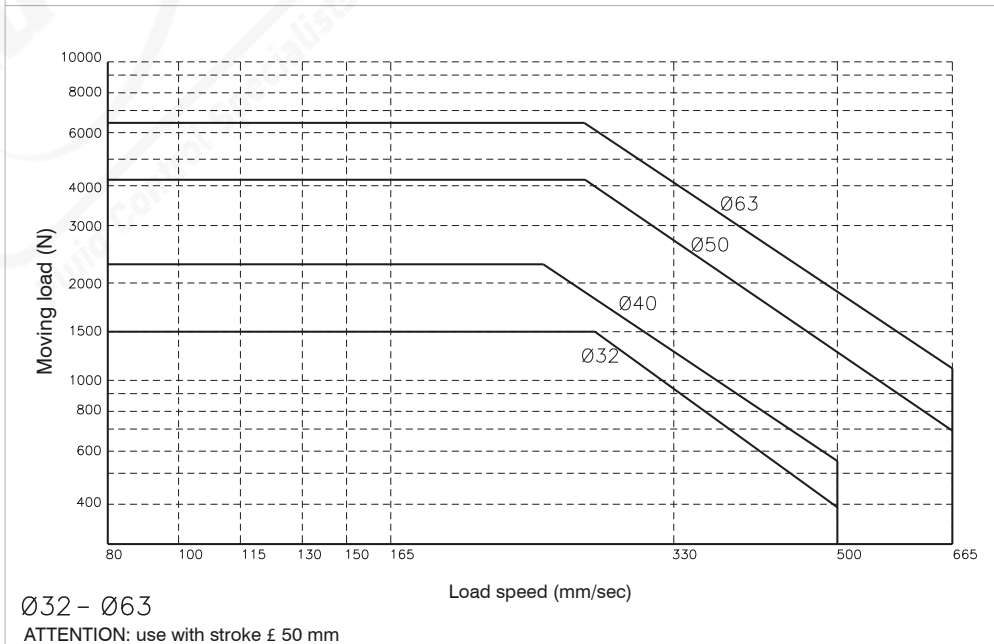
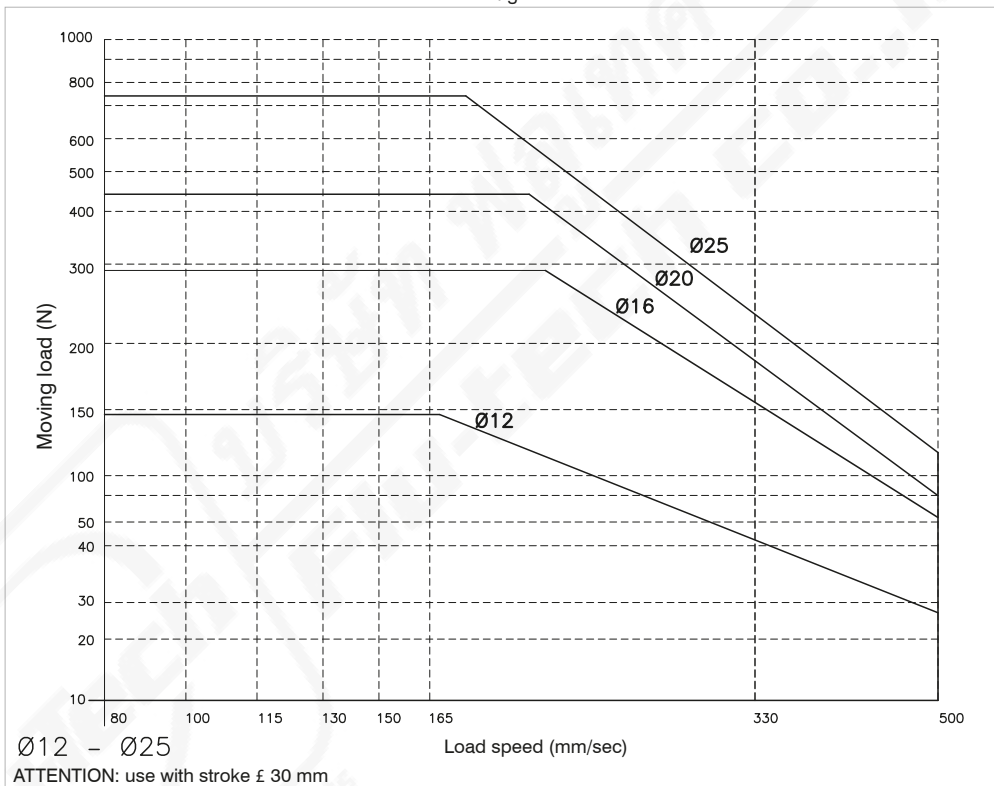

Operating criteria  
Handling applications

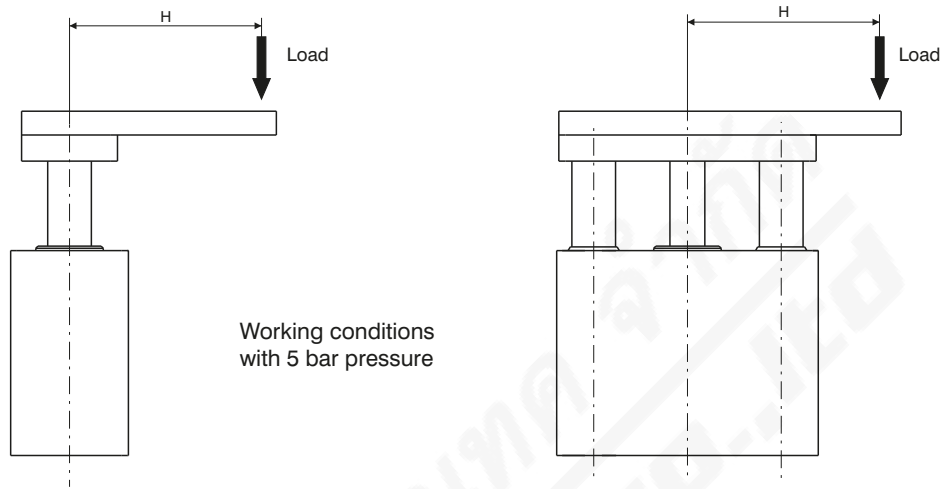

Control unit with bronze bushes

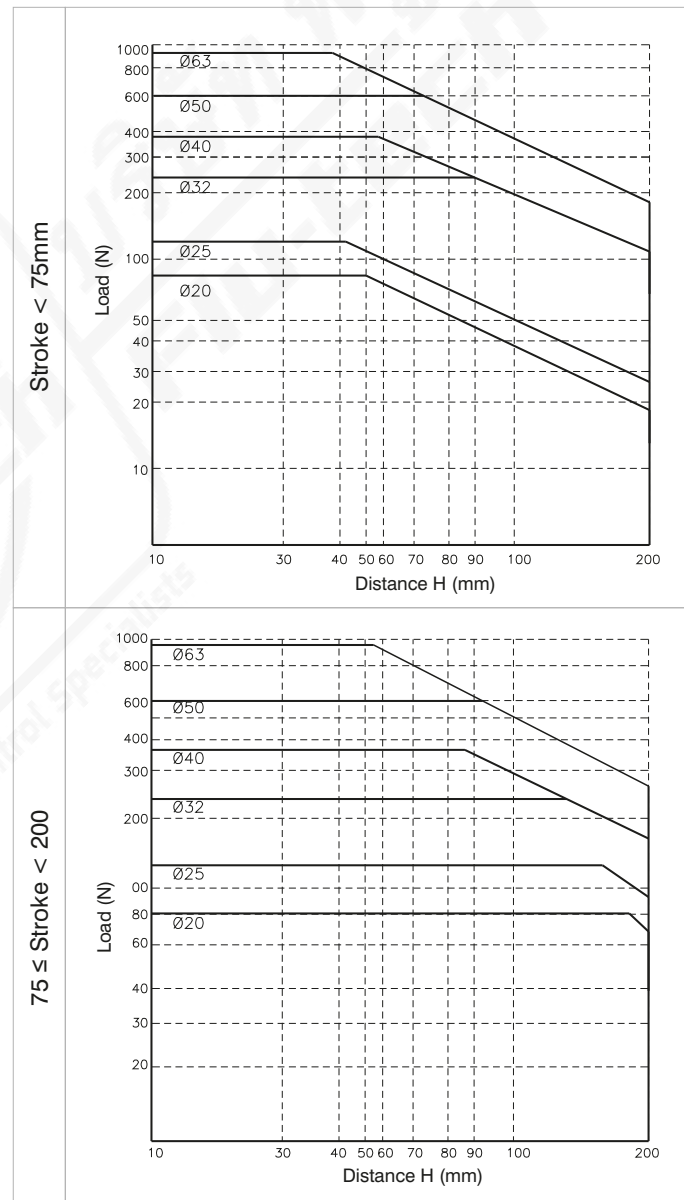



Operating criteria

Handling applications

Control unit with bearing bushes

