

# SERV-OIL Single-Point Injection Lubricators for Air Tools

Port Sizes: 1/2, 3/4



Model Shown: A64061

## SPECIFICATIONS

**Air Flow:** Maximum inlet pressure of 150 psig (10 bar) and a pressure drop of 3 psi (0.2 bar):

1/2 NPTF — 4-60 scfm (2-28 dm<sup>3</sup>/s)

3/4 NPTF — 4-90 scfm (2-43 dm<sup>3</sup>/s)

**Ambient/Media Temperature:**

40° to 125°F (4° to 52°C).

**Flow Valve:** Zinc body.

**Operating Pressure Range:**

60-150 psig (4.1-10.3 bar)

**Pulse Counter:** Adjustable to operate the Servo-Meter on every cycle, every 5th cycle, or every 10th cycle.

**Reservoir:** Integral, unpressurized. 10-Ounce (300-ml) capacity transparent nylon with quick-fill cap. Optional M476R reservoir. Integral reservoir can be eliminated if a central-fill system is employed

**Servo-Meter:** Aluminum body; acetal end caps. 1-Drop rating; optional 1/2-drop or 2-drop rating. Transparent sight indicator gives visual verification of oil delivery.

**Tubing:** Optional 25 feet (8 meters) of oil-filled tubing and 420-160 check valve.

**Oil Viscosity Range:** 31-1000 @ 100°F (37.8°C)

The single-point lubricator (**SPL**) is specifically designed to lubricate air tools. It cannot be used for general lubrication of components other than air tools. For other single-point applications see the single-point downstream lubricator or multipoint lubricators on the following pages.

An **SPL** is installed in the air supply line upstream of the air tool. When the tool is cycled the **SPL** injects a precise amount of oil at the air inlet of the tool. Both the amount of oil and the frequency of injection are adjustable.

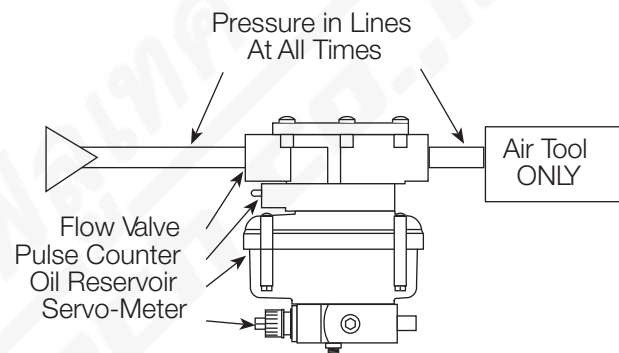

Sub-Assemblies and Installation of SPL

The four sub-assemblies shown in the drawing above make up the **SPL**.

**Flow Valve.** The air supply line is connected to the inlet of the flow valve. 1/8-Inch nylon tubing is connected to the nozzle in the outlet port, and then runs inside the air line to within a short distance of the air tool. A check valve must be installed on the end of the 1/8" nylon tube.

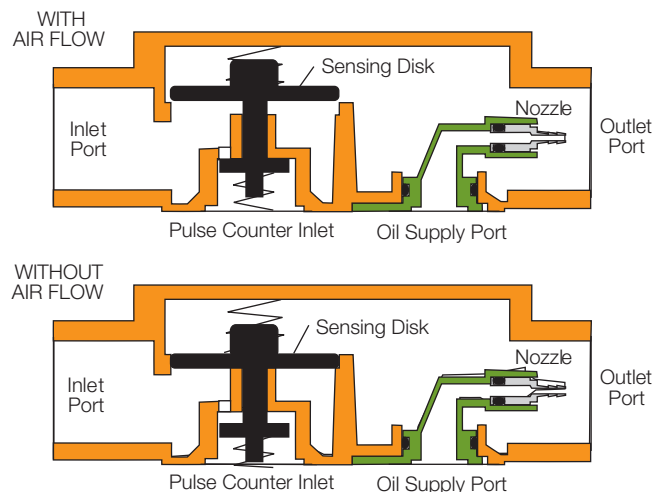

SPL Flow Valve  
(continued on next page)

When the air tool is at rest, no air flows in the valve. When the tool is triggered the differential pressure across the sensing disk opens a passage to the pulse counter.

**Pulse Counter.** When the air tool is triggered the pulse counter receives an air signal from the flow valve. A three-position switch on the counter is set to allow the air signal to proceed to the Servo-Meter on every cycle, every 5th cycle, or every 10th cycle. This is one of the means of controlling the amount of lubrication that will be supplied to the air tool.

**Servo-Meter.** The Servo-Meter is an air-actuated, positive-displacement oil pump. It injects oil with each signal from the pulse counter. These signals can be every time, every 5th time, or every 10th time the air tool is triggered. The frequency is determined by the setting of the pulse counter.

To actuate the Servo-Meter the signal received must have a pressure of at least 60 psig (4 bar). When actuated the Servo-Meter delivers a precise amount of oil to the nozzle in the outlet port of the flow valve, and is then carried by a nylon line to the air tool. A transparent sight indicator on one end of the Servo-Meter gives visual verification of oil delivery.

By means of the adjusting knob on the end of the Servo-Meter, oil delivery can be reduced in precise increments from the maximum rating down to 10% of the maximum rating. (30% for 2 drop units.)

**Oil Reservoir.** The integral oil reservoir is made of tough, transparent nylon, and has a capacity of 10 ounces (300

ml). It has a quick-fill cap, and since the reservoir is not pressurized it can be filled at any time. It can also be used with a central-fill system. Gravity fill is recommended, but fill pressure can be up to 30 psig (2 bar).

An SPL can be ordered without an integral reservoir, in which case a sight-dome air eliminator is available for use with a central-fill system.

### DIMENSIONS inches (mm)

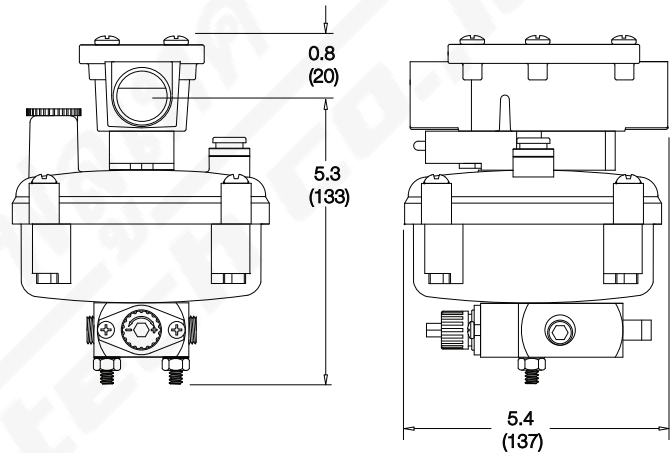

### ORDERING INFORMATION

Change the letters in the sample model number below to specify the SPL you want.

**P A 6 4 0 4 1 Y W**

#### OIL-FILLED TUBING

With 25 ft (8 m) of tubing ..... Leave Blank  
and 420-160 check valve.

Without tubing..... P

#### RESERVOIR

With integral reservoir ..... 4

No integral reservoir. Also specify  
0 if ordering **M476R** reservoir  
under **OPTIONS** at right..... 0

#### PORT SIZE

1/2 NPTF..... 4

3/4 NPTF..... 6

#### PORT TYPE

NPTF threads ..... Leave Blank

BSP threads ..... W

#### OPTIONS (More than one option can be chosen)

None ..... Leave Blank

Two pulse counters ..... BB

Frequency controller ..... F

M476R reservoir. Also specify 0  
under **RESERVOIR** at left..... R

#### SERVO-METER RATING

One drop (0.030 ml) ..... 1

Two drops (0.060 ml) ..... 2

Half drop (0.015 ml) ..... 5