

MECAIR

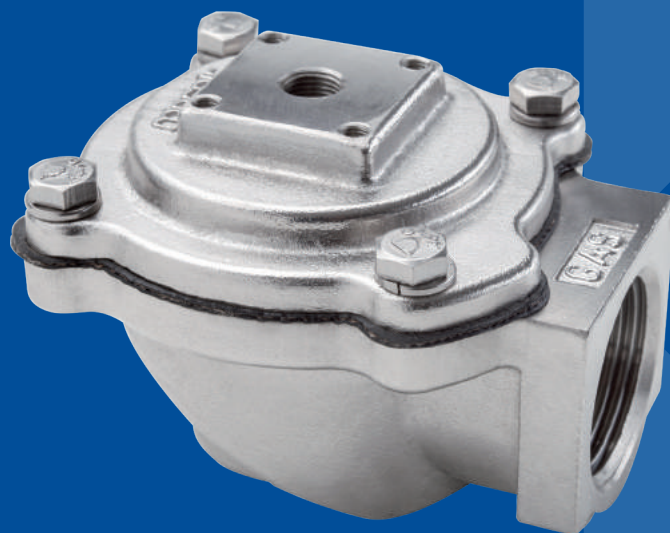

200 SERIES AISI

THREADED VALVES

MECAIR - 200 SERIES AISI THREADED VALVES

PRODUCT LEAFLET



DESCRIPTION

The 200 SERIES in stainless steel is a range of diaphragm valves suitable for dust collector applications, in particular for reverse pulse-jet filter cleaning of filter bags, cartridges, envelope filters, ceramic filters and sintered metal fibre filters. The 200 Series valve has the inlet port at 90° to the outlet port. The range includes two models, which comprises a 1" valve and a 1½" size valve. Both models have a single diaphragm. The inlet and outlet ports have threaded female gas connections. The 200 Series valves in stainless steel, are manufactured in AISI316L. These valves are particularly appropriate for installation in aggressive environments where there is risk of corrosion. Chemical processes, off-shore refineries and plants, and nuclear environments are just some typical applications where the Series 200 valve in stainless steel can be mounted. With a special diaphragm which has FDA Accreditation/Approval, the stainless steel valve can also be installed in special environments including, pharmaceutical, food and grain, wheat and flour, and in any other environment where food or medical grade is required. The Series 200 in stainless steel is available in 2 versions:

- **VXP**, with solenoid pilot mounted on board
- **VXM**, which can be utilised with a remote pneumatic connection – only 1" valve using a CSN or CXD enclosure, or alternatively for both models, 1" and 1½" valves, with explosion-proof pilot mounted on board. Explosion-proof pilot with ATEX Certification is also available in stainless steel – AISI316L.

GENERAL CHARACTERISTICS

FLUIDS	Filtered air and oil free
DIAPHRAGM	Standard NBR: -20°C/+80°C Viton: -29°C/+232°C FDA PTFE/Gylon: -268°C/+260°C EPDM: -20°C/+120°C
PRESSURE RANGE	From 0.5 to 7.5 bar

CONSTRUCTION FEATURES - VALVE

COVER	AISI 316L
BODY	AISI 316L
PILOT	Stainless steel
SPRING	Stainless steel
BOLTS AND SCREWS	Stainless steel
DIAPHRAGM BACKING DISK	Stainless steel

ELECTRICAL CHARACTERISTICS - SOLENOID

COIL INSULATION	Class H
DIN SOCKET CONNECTOR	Pg9 connection
DIN SOCKET STANDARD	EN175301 - 803 / A/ISO 4400
DIN SOCKET OPTIONAL	94/9/CE ATEX II 2GD T4 IP67
ISOLATION CLASS DIN SOCKET	VDE 0110 - 1/89
ELECTRICAL PROTECTION	IP65 EN60529
VOLTAGE RANGE	24 V AC - 50 Hz 110/127 V AC - 50/60 Hz* 220/240 V AC - 50/60 Hz 110 V DC 48 V DC* 24 V DC
POWER ABSORPTION	19 W/AC 15 W/DC
AMBIENT TEMPERATURE	-20°C/+60°C

* Note this is a dual voltage solenoid.

MODEL	PORT SIZE Ø	NO. DIAPH.	PRESSURE RANGE (BAR)		WEIGHT KG	COIL	KV	CV
			MIN.	MAX.				
VXP208	1"	1	0.5	7.5	1.13	Yes	21	24.4
VXP212	1½"	1	0.5	7.5	2.67	Yes	37	43.0
VXM208	1"	1	0.5	7.5	0.85	No	21	24.4
VXM212	1½"	1	0.5	7.5	2.39	No	37	43.0

HOW TO ORDER

Part Number Code: **VXM/VXP 2 08 110/50**

Valve

P VXP - with integral pilot
M VXM - without pilot

2

"200 Series"

Voltage and frequency required

Valve connection diameter

- 08 = 1"
- 12 = 1½"

MECAIR - 200 SERIES AISI THREADED VALVES

PRODUCT LEAFLET

DIMENSIONS (MM)

VXP 208 - 212

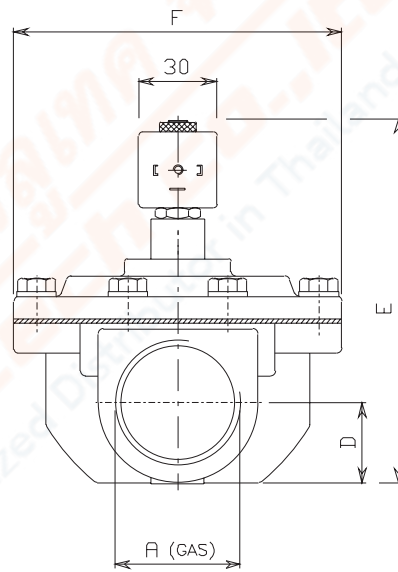
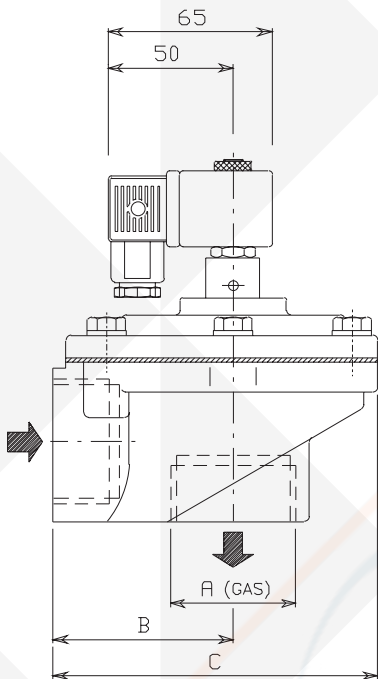

VXM 208 - 212

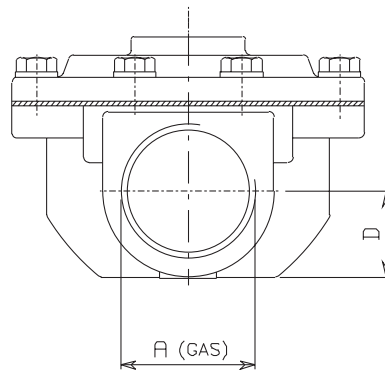
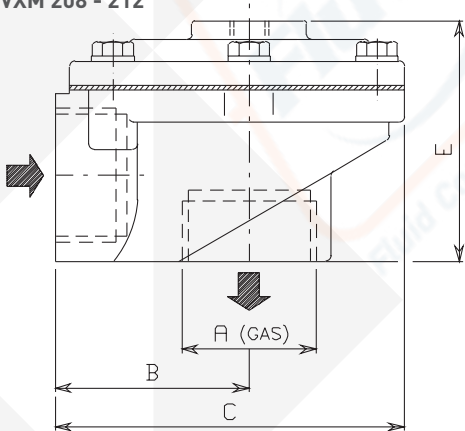

MODEL	Ø A	B	C	D	E	F	WEIGHT KG	MODEL	E	Ø L	WEIGHT KG	PRESSURE RANGE (BAR)		NO. DIAPH.
												MIN.	MAX.	
VXP208	1"	52	90	23	135	74	1.13	VXM208	60	1/8"	0.85	0.5	7.5	1
VXP212	1½"	72	130	31	60	135	2.67	VXM212	85	1/8"	2.39	0.5	7.5	1

MECAIR - 200 SERIES AISI THREADED VALVES

PRODUCT LEAFLET

SPARE PARTS

VXP 208 - 212

VXM 208 - 212

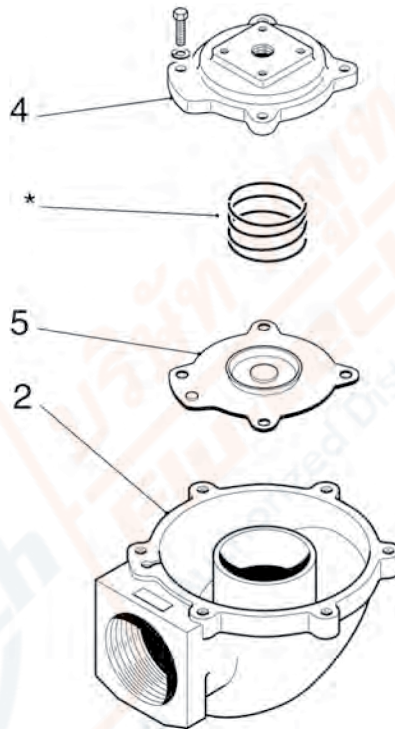
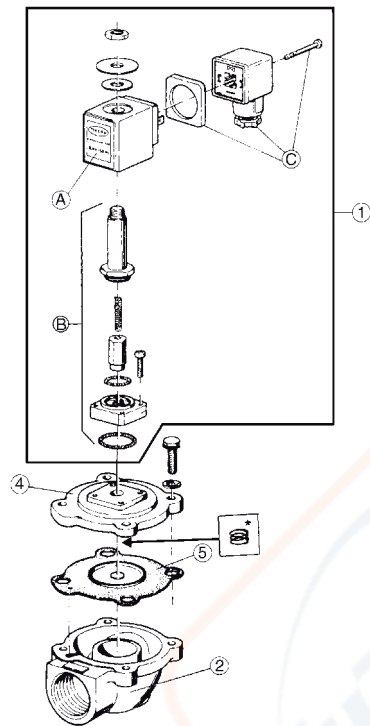

STANDARD VERSION

POS.	DESCRIPTION	CODE
1	a) Solenoid*	a) KIT SLB8*
	b) Pilot group complete with fixing screws	b) KIT ESL8
	c) DIN connector PG9 EN175301-803 IP65	c) KIT PLG9

POS	DESCRIPTION	CODE	
		VXM/VXP208	VXM/VXP212
4	Top cover	KIT M110090	KIT M110096
5	Diaphragm	KIT DB18/G-I KIT DB18VI (VITON)	KIT DB112i KIT DB112VI/S (VITON)
2	Valve body	KIT M100209	KIT M100216

* Specify voltage and frequency.