



CXD

HAZARDOUS ENCLOSURES

MECAIR - CXD

HAZARDOUS ENCLOSURES

PRODUCT LEAFLET

DESCRIPTION

The CXD explosion-proof solenoid enclosure is designed for those applications where the atmosphere may present the possibility of combustion. The CXD enclosure is explosion proof with the following grade of protection: II 2 G Ex d IIB T5 - II 2 D Ex tD A21 IP67 T100°C. This ensures that any spark, resulting from the electrical activation of the solenoid, will be restricted within the interior of the enclosure.

The CXD explosion-proof enclosure is certified in accordance with the European Directive 94/9/CE (ATEX). The CXD Series is available in two models/sizes:

- **CXD 4:** from 1 to 4 solenoid pilots
- **CXD 8:** from 5 to 8 solenoid pilots

Each solenoid pilot, energised in sequence, commands a corresponding VEM type diaphragm valve, by way of a 6 mm internal diameter pneumatic tube being less than 2 metres in length. The control consists in releasing the compressed air from the upper chamber of the valve and its piping. The CXD enclosure is supplied complete with fixing brackets. The common terminal is pre-wired.

The CXD solenoid base is made of extruded aluminium, while the cover is in diecast aluminium, both are anodised for protection against aggressive agents. The CXD enclosure features a common exhaust port, located on the underside of the unit. The exhaust is open to the atmosphere and can be piped or muted with a silencer. Within the enclosure a safety device is installed in order to cut off the power supply to the solenoids in case of an abnormal increase in temperature within the enclosure. This device is recognised as GTRM-1. It is possible to install within the enclosure a heat resistor group complete with thermostat for installation in cold climates where low temperature is a problem. GTRM-2 maintains an internal temperature of approximately +4°C, and is available in two models:

- GTRM 50, for CXD 4
- GTRM 120, for CXD 8

PLEASE NOTE: single diaphragm 1½" VEM valve not suitable with remote pilot.



GENERAL FEATURES

OPERATING TEMPERATURE	-20°C/+60°C
WEIGHT	CXD 4 - 5 kg CXD 8 - 8.5 kg

CONSTRUCTION FEATURES

TOP COVER	Diecast aluminium (anodised)
BASE	Extruded aluminium (anodised)
PILOT	Stainless steel
GASKETS	NBR

ELECTRICAL FEATURES

COIL INSULATION	Class H
ELECTRICAL CONNECTION	2 × ½" NPT for CXD 1-4 2 × ¾" NPT for CXD 5-8
ELECTRICAL PROTECTION	II 2 G Ex d IIB T5 - II 2 D Ex tD A21 IP67 T100°C
VOLTAGE AND FREQUENCY	AC: 24/110/220 V 50/60 Hz DC: 24/110 V
PNEUMATIC CONNECTIONS	To VEM Valves ¼" female Gas Common exhaust, No. 2 connections 3/8" female Gas
APPROVALS - INERIS	INERIS 03 ATEX 0069X II 2GD

HOW TO ORDER

Part Number Code: **CXD 5 - ..V/..Hz - R**

CXD

Explosion-proof enclosure

Number of solenoid pilots

CXD 1-2-3-4 (small enclosure)
CXD 5-6-7-8 (large enclosure)

Heater element with thermostat

Available in two versions:
GTRM 50 = 70 WATT (for CXD 4)
GTRM 100 = 100 WATT (for CSN 8)

Coil voltage/frequency

Nominal values	Operating range
24/50	24 V/50 Hz
24/60	24 V/60 Hz
24/DC	24 V/DC 15W
110/50	110-127 V/50 Hz
110/60	110-127 V/60 Hz
110/DC	110 V / DC
220/50	220-240 V/50 Hz
220/60	220-240 V/60 Hz

MECAIR - CXD HAZARDOUS ENCLOSURES

PRODUCT LEAFLET

DIMENSIONS (MM)

CXD 4

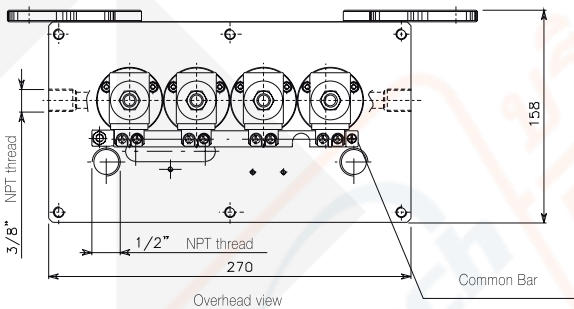
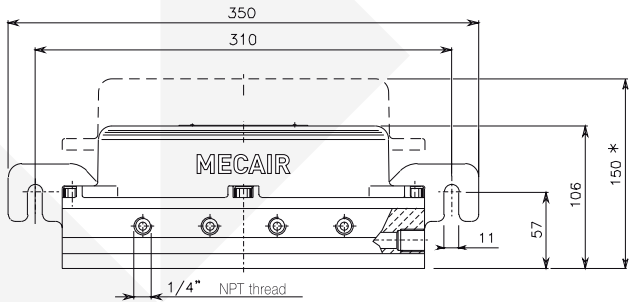

CXD 8

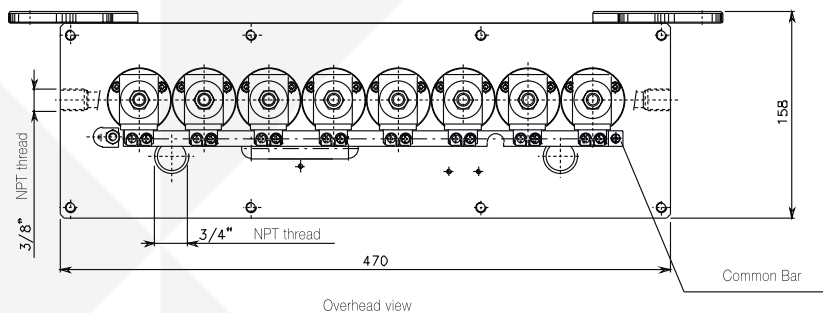
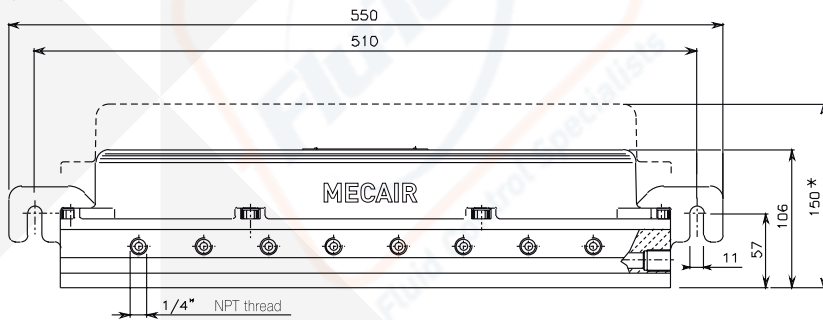

MECAIR - CXD HAZARDOUS ENCLOSURES

PRODUCT LEAFLET

SPARE PARTS

CXD 4 - CXD 8

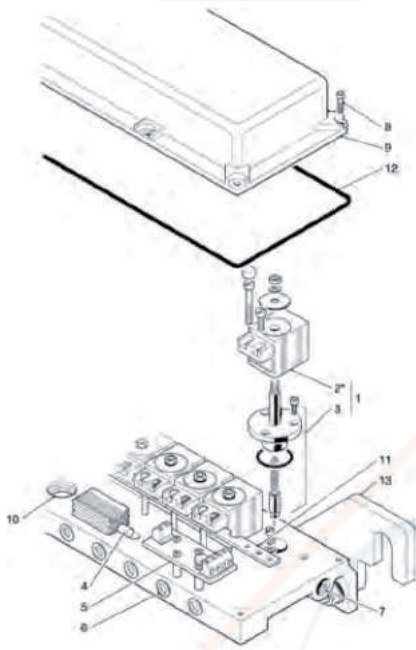

POS.	DESCRIPTION	CODE
1	Pilot group complete with coil	KIT ELA2 - ../..*
2	Solenoid coil*	KIT SA2 - ../..*
3	Ferrule tube complete	KIT ECL 28 X
4	Heater for CXD4	KIT GRT 50 - 220 V 50/60 Hz
4	Heater for CXD8	KIT GRT 100 - 220 V 50/60 Hz
5	Circuit - for internal temperature control	KIT GTRM - 1
5	Circuit - for internal temperature control and resistor control	KIT GTRM - 2

* Specify voltage and frequency (or DC)

RECOMMENDED SPARE PARTS

For start-up:

≥ 5% of supply (min. 1 piece): • pilot group (1), complete with coil.

For first two years of service:

≥ 10% of supply (min. 2 pieces): • pilot group (1), complete with coil.

ELECTRICAL CONNECTIONS

A	Pilot group complete with coil
B	Connect the solenoid coils as described in drawing [E1 if without the heater or E2 if with heater] Use a multi-core cable to: 1 wire to pre-wired common terminal (11) and 1 wire to each solenoid coil
C	Connect the thermostatically controlled heater (optional) as per drawing [E2]
D	Refit the top cover (9) ensuring the correct position of the seal (12)

E1 - INTERNAL TEMPERATURE CONTROL

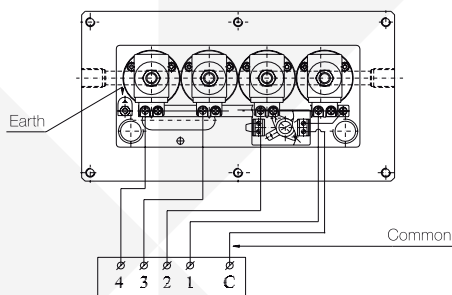

E1 - INTERNAL TEMPERATURE CONTROL (GTRM-1)

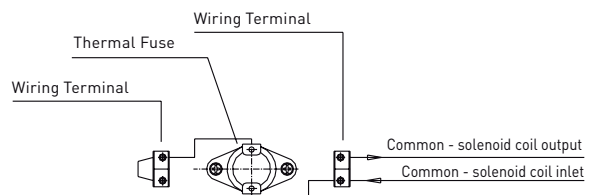

MECAIR - CXD HAZARDOUS ENCLOSURES

PRODUCT LEAFLET

E2 - INTERNAL TEMPERATURE CONTROL AND RESISTOR

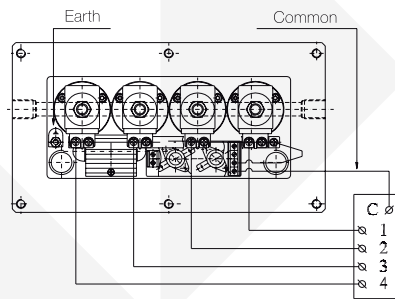

E2 - INTERNAL TEMPERATURE CONTROL AND THERMOSTAT (GTRM-2)

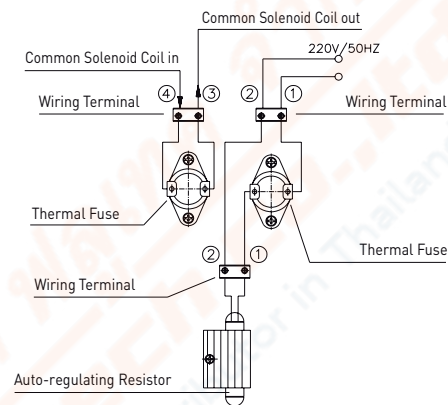

PNEUMATIC CONNECTIONS

Pneumatic connections (6) 1/4" female Gas - Valve connection with:

- Tube Ø 6/8 mm - Rilsan or stainless steel
- Max. length 2 metres

Fluid: Compressed air (or nitrogen) dried, filtered and oil free - min/max pressure 0.5-7.5 bar

Exhaust connections (7): Connection 1/8" female Gas:

- open in atmosphere
- or muted with silencer
- or piped to an external tank for nitrogen recovery.

PNEUMATIC CONNECTIONS ON TANKS

Certified in accordance with ATEX 94/9/EC

