



Servo-assisted 3/2 way Solenoid Valve for pneumatics

- High flow-rate capacity
- Reduced power consumption
- Single or manifold mounting
- Standard, Ex mb, Ex eb mb and Ex ia versions
- Threaded port G 1/4" and NPT 1/4"

Product variants described in the data sheet may differ from the product presentation and description.

Can be combined with

	Type 2507 ▶ Cable plug, form B according to industry standard
	Type 2516 ▶ Cable plug, form C according to DIN EN 175301-803
	Type 2518 ▶ Cable plug, form A according to DIN EN 175301-803
	Type 2030 ▶ Pneumatically operated 2/2 way diaphragm valve CLASSIC with plastic valve body
	Type 1087 ▶ Timer, form A according to DIN EN 175301 - 803

Type description

The Type 6518 is a servo-assisted 3/2-way valve and the Type 6519 is a 5/2 or 5/3-way valve. Together, they form a product line. The valves can be used individually or in blocks. The valves work without a continuous air consumption and are used for the pneumatic control of double or single-acting actuators. The use of high quality materials makes it possible to use these valves in the open air and under chemical atmospheres. The product line contains units with Ex-Approvals and NAMUR flange interface. Valves with circuit function C, D and H monostable are certified acc. IEC 61508 as SIL2.

Table of contents

1. General technical data	3
2. Product versions	4
2.1. Standard version.....	4
2.2. Ex mb- und Ex eb mb version	5
2.3. Ex i version.....	6
3. Circuit functions	6
4. Materials	7
4.1. Chemical Resistance Chart – Bürkert resistApp.....	7
5. Dimensions	7
5.1. Pneumatic module Type MP07	7
5.2. Standard version 3/2-way valve, circuit function C and D.....	8
With plug form B or C	8
With plug form A	8
5.3. Ex mb-/eb mb- version 3/2-way valve, circuit function C and D.....	9
With moulded cable (3 m long) (Ex mb).....	9
With terminal box (Ex eb mb).....	9
5.4. Ex i version 3/2-way valve, circuit function C	10
5.5. ATEX version cable coil and terminal box.....	11
6. Product design and assembly	12
6.1. Block construction	12
7. Product accessories	13
7.1. Cable glands for ATEX/IECEX terminal box	13
7.2. Special tool to turn the terminal box.....	13
8. Ordering information	14
8.1. Bürkert eShop – Easy ordering and quick delivery.....	14
8.2. Bürkert product filter	14
8.3. Ordering chart.....	15
Standard version with plug form A	15
Standard version with plug form B	16
Standard version with plug form C	17
Ex mb version (with moulded cable).....	17
Ex eb mb version (with terminal box).....	18
Ex i version (310 Ohm)	18
8.4. Ordering chart accessories.....	19
Cable plug Type 2513, form A according to DIN EN 175301 -803	19
Cable plug Type 2518, form A according to DIN EN 175301 -803	19
Cable plug Type 2507, form B according to industry standard	20
Cable plug Type 2516, form C according to DIN EN 175301 -803.....	20
Cable glands for ATEX/IECEX terminal box	21

1. General technical data

Product properties	
Dimensions	Detailed information can be found in chapter “5. Dimensions” on page 7.
Material	
Body	Polyamide, reinforced glass-fibre
Threaded bushing	Brass (stainless steel on request)
Seal	NBR and PUR
Manual override	Standard
Nominal diameter	DN 8
Performance data	
Switching time ¹⁾	
Opening	Pressure build-up 0...90 %
Closing	Pressure reduction 100...10 %
Compressed air quality	ISO 8573 - 1:2010, class 7.4.4 ²⁾
Nominal operating mode	100 % continuous operation
Medium data	
Operating medium	Neutral medium, e.g. lubricated or non-lubricated compressed air
Process/Port connection & communication	
Pneumatic connection	Supply ports 1, 3, 5: Threaded G ¼, NPT ¼ Working ports 2, 4: Threaded G ¼, NPT ¼
Electrical connection	Plug form A acc. to DIN EN 175301 - 803 Plug form B acc. to DIN EN 175301 - 803 Plug form C acc. to DIN EN 175301 - 803
Product accessories	
Cable plug Type 2518 – form A (standard)	Detailed information can be found in chapter “Cable plug Type 2518, form A according to DIN EN 175301 - 803” on page 19.
Cable plug Type 2507 – form B (standard)	Detailed information can be found in chapter “Cable plug Type 2507, form B according to industry standard” on page 20.
Cable plug Type 2516 – form C (standard)	Detailed information can be found in chapter “Cable plug Type 2516, form C according to DIN EN 175301 - 803” on page 20.
Cable plug Type 2513 – form A for the EX area cat. 3	Detailed information can be found in chapter “Cable plug Type 2513, form A according to DIN EN 175301 - 803” on page 19.
Approvals and certificates	
Degree of protection	IP65 with cable plug
Environment and installation	
Installation position	Any, preferably actuator face up

1.) Measurement at 6 bar and +20 °C at the valve outlet

2.) To prevent freezing of the expanded compressed air, the pressure dew point must be at least 10 K lower than the temperature of the medium.

2. Product versions

2.1. Standard version

Note:

For general technical data, see [“1. General technical data” on page 3.](#)

Type 6518 is a pilot operated 3/2-way valve (normally closed or open). The valve width of 32 mm allows high flow rates. The valves can be used individually or in blocks.

Product properties	Coil size 24.5 mm	Coil size 32 mm
Switching time		
Opening	20 ms	20 ms
Closing	40 ms	40 ms
Weight	212 g	384 g
Electrical data		
Operating voltage	24 V DC	24 V DC 24/ 110/ 230 V/ 50...60 Hz
Power consumption		
Inrush	-	AC: 11 VA AC: 6/2 VA/W DC: 2 W
Hold (hot coil)	DC: 2 W	DC: 2 W
Medium data		
Medium temperature	-10 °C...+50 °C	-10 °C...+50 °C
Process/Port connection & communication		
Electrical connection	Plug form B acc. to DIN EN 175301-803 Plug form C acc. to DIN EN 175301-803	Plug form A acc. to DIN EN 175301-803
Environment and installation		
Ambient temperature	-25 °C...+55 °C	-25 °C...+55 °C

2.2. Ex mb- und Ex eb mb version

**Note:**

- Ex mb (with moulded cable) or Ex eb mb (with terminal box)
- The maximum medium temperature may never exceed the permissible temperature class (T4 135 °C, T5 100 °C, T6 85 °C) minus 5K.

The approval Ex m is achieved by the mounting of an approved push-over coil. The cable connection and the cable are non-detachable and sealed together with the valve. The valves can be used individually or in blocks.

**Product properties****Switching time**

Opening	20 ms
Closing	50 ms
Weight	600 g

Electrical data

Operating voltage	24/ 110/ 230 V/UC
Voltage tolerance	+ 10 %

Medium data

Medium temperature	- 10 °C...+ 50 °C
--------------------	-------------------

Process/Port connection & communication

Electrical connection	3 m cable, moulded Terminal box (without fuse)
-----------------------	---

Approvals and certificates**Ignition protection class (ATEX and IECEx)**

Coil with cable	EPS 18 ATEX 1232 X / IECEx EPS 18.0110X II 2G Ex mb IIC T5 Gb II 2D Ex mb IIIC T95 °C Db
Coil with terminal box	EPS 18 ATEX 1232 X / IECEx EPS 18.0110X II 2G Ex eb mb IIC T5 Gb II 2D Ex mb tb IIIC T95 °C Db

Environment and installation

Ambient temperature	-25 °C...+ 50 °C
---------------------	------------------

2.3. Ex i version



Note:

- The maximum medium temperature may never exceed the permissible temperature class (T4 135 °C, T5 100 °C, T6 85 °C) minus 5K.
- The units may only be used in potentially explosive atmospheres in the manner approved by the admission board, i.e. the permissible maximum electrical values must be observed.
- The valve is intended for operation on 24 V DC outputs via the intermediate switching of a corresponding intrinsically-safe operating resource (isolating module or barrier).

The intrinsically-safe Type 6518 Ex i valve consist of an intrinsically-safe pilot control and a pneumatic amplifier. The diaphragm-controlled valve seats work with very low friction, ensuring reliable switching of the valve, even after long shut-down periods.

Product properties		
Switching time		
Opening	75 ms	
Closing	115 ms	
Weight	580 g	
Electrical data		
Function values for switching function valve	At +20 °C	At +55 °C
Minimum switching current	29 mA	29 mA
Nominal resistance coil	310 Ω	360 Ω
Minimum terminal voltage	9.0 V	10.4 V
Conformity specifications		
Ui	35 V	
Ii	0.9 A	
Pi	1.1 W	
Medium data		
Medium temperature	-10 °C...+50 °C	
Process/Port connection & communication		
Electrical connection	Cable plug Type 2518, form A acc. to DIN EN 175301-803. Detailed information can be found in chapter “ Cable plug Type 2518, form A according to DIN EN 175301-803 ” on page 19.	
Approvals and certificates		
Approvals	EPS 18 ATEX 1 088 / IECEx EPS 18.0038 X II 2G Ex ia IIC T6 Gb II 2D Ex ia IIIC T135 °C Db	
Environment and installation		
Ambient temperature	-25 °C...+55 °C	

3. Circuit functions

Circuit functions	Description
	Type: C, solenoid valve 3/2-way Servo-controlled Normally closed
	Type: C, solenoid valve 3/2-way Servo-controlled, with manual override Normally closed
	Type: D, solenoid valve 3/2-way Servo-controlled, with manual override Normally opened

4. Materials

4.1. Chemical Resistance Chart – Bürkert resistApp

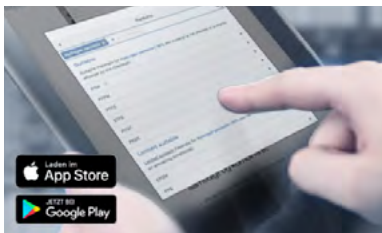

Bürkert resistApp – Chemical Resistance Chart

You want to ensure the reliability and durability of the materials in your individual application case? Verify your combination of media and materials on our website or in our resistApp.

[Start Chemical Resistance Check](#)

5. Dimensions

5.1. Pneumatic module Type MP07

Note:

- Dimensions in mm
- n = no. of valves, maximum 12
- Block mounting on wall or with DIN rail 50022 or 50023
- Valve mounting on the pneumatic modules Type MP07 by means of included M4 screws

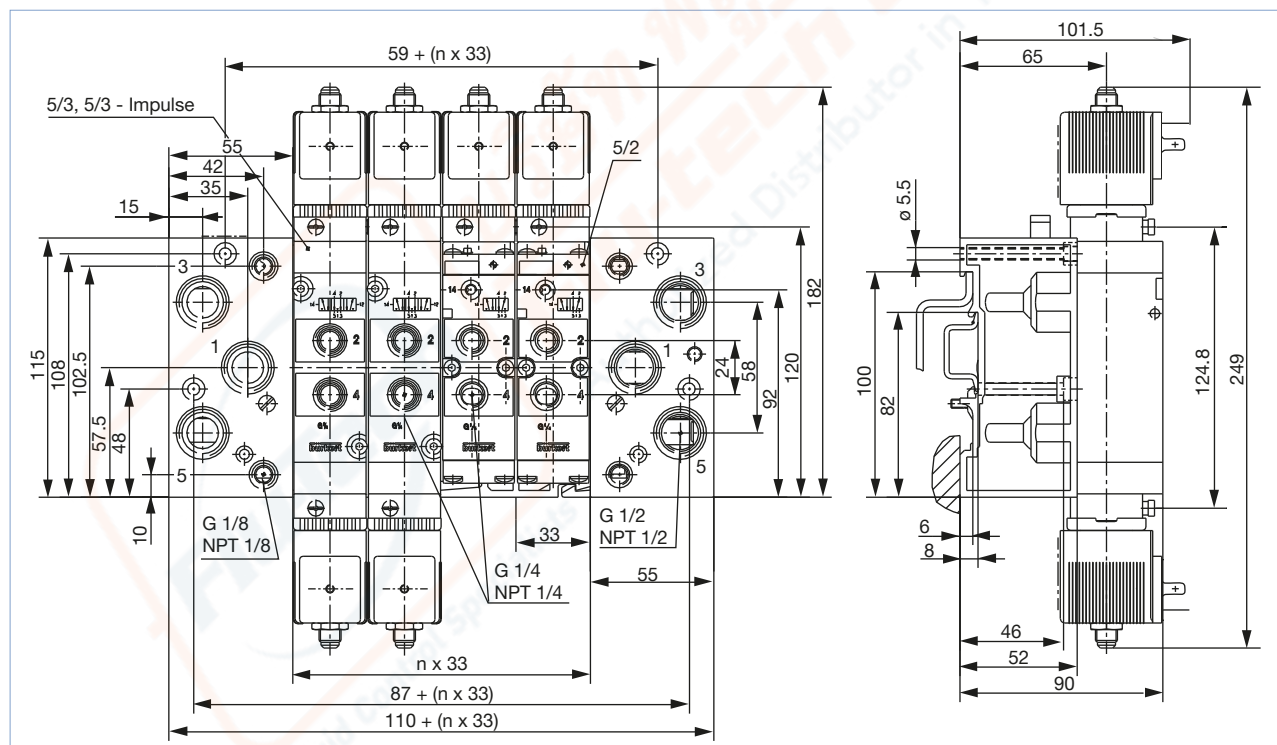

DTS 1000011064 EN Version: B Status: RL (released | freigegeben | valide) printed: 15.02.2023

5.2. Standard version 3/2-way valve, circuit function C and D

Note:

Dimensions in mm

With plug form B or C

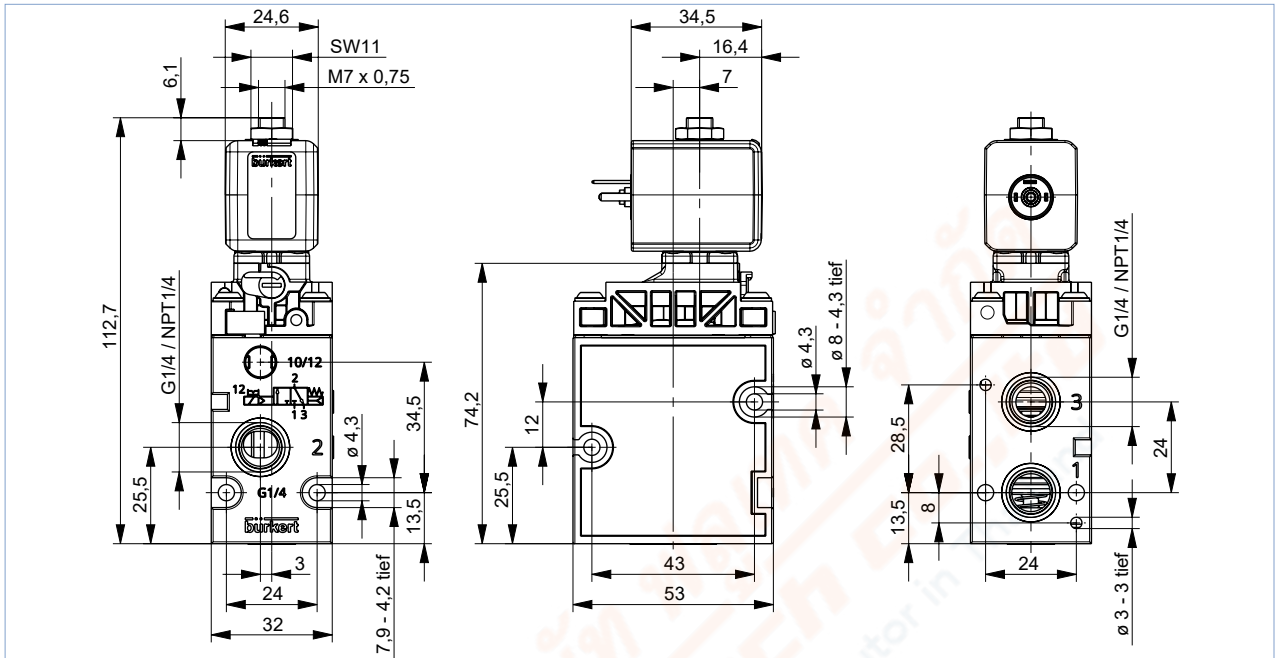

With plug form A

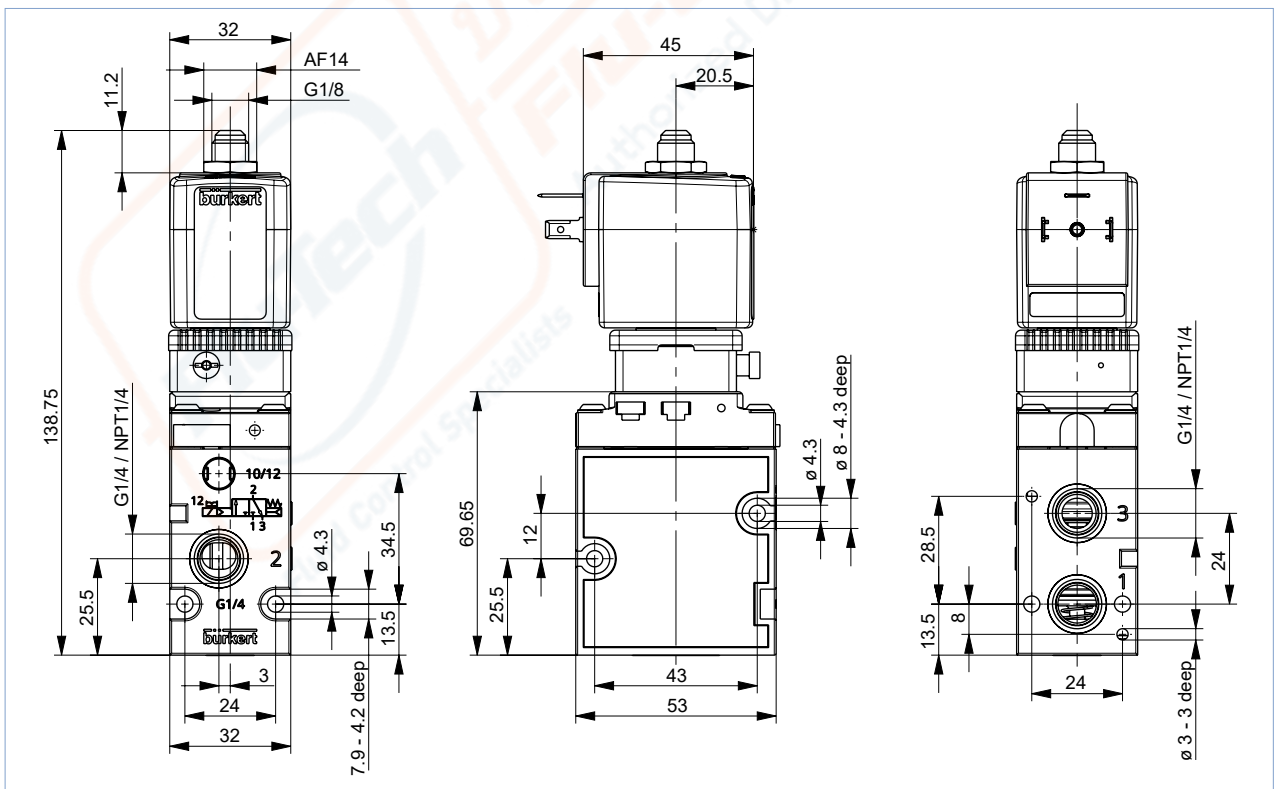

DTS 1000011064 EN Version: B Status: RL (released | freigegeben | valide) printed: 15.02.2023

5.3. Ex mb-/eb mb- version 3/2-way valve, circuit function C and D

With moulded cable (3 m long) (Ex mb)

Note:

Dimensions in mm

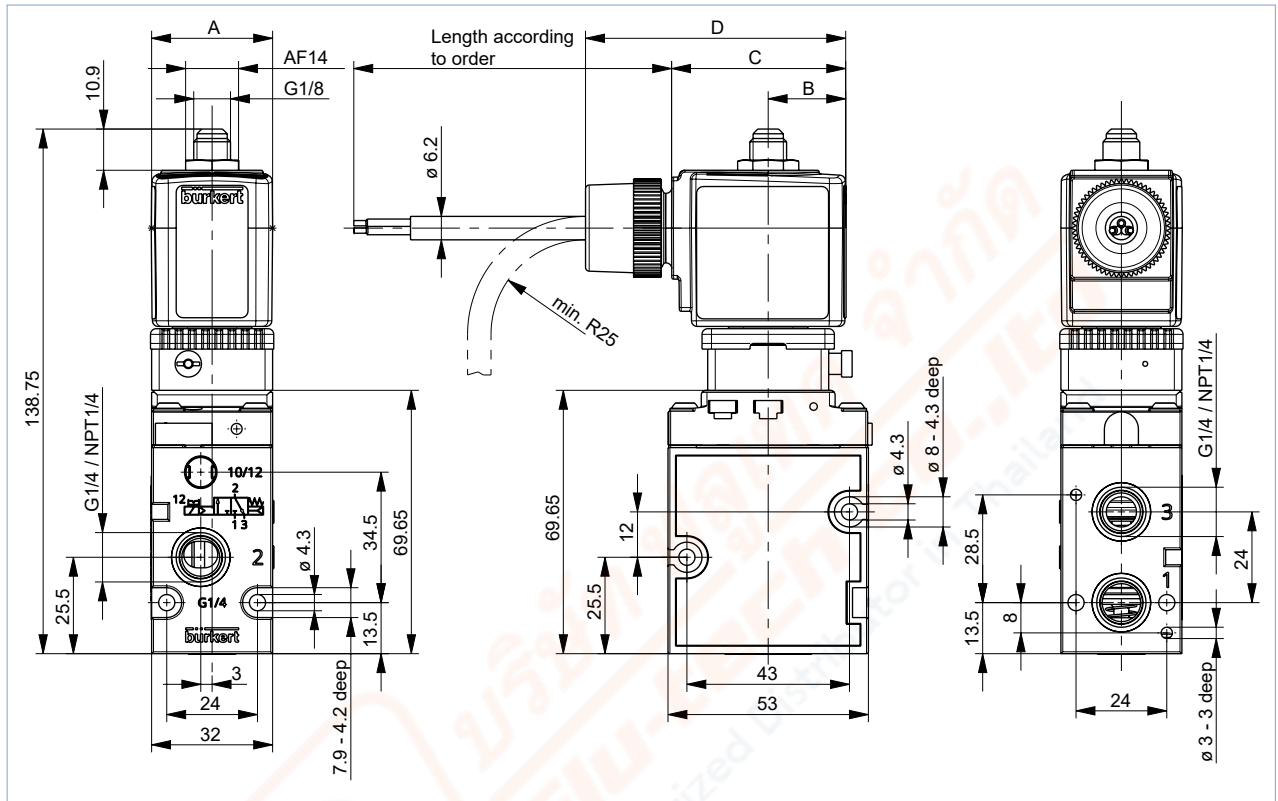
**With terminal box (Ex eb mb)****Note:**

- The dimensions of the housing are identical to the version with molded cable.
- For the coil dimensions, see chapter "5.5. ATEX version cable coil and terminal box" on page 11.

5.4. Ex i version 3/2-way valve, circuit function C

Note:
Dimensions in mm

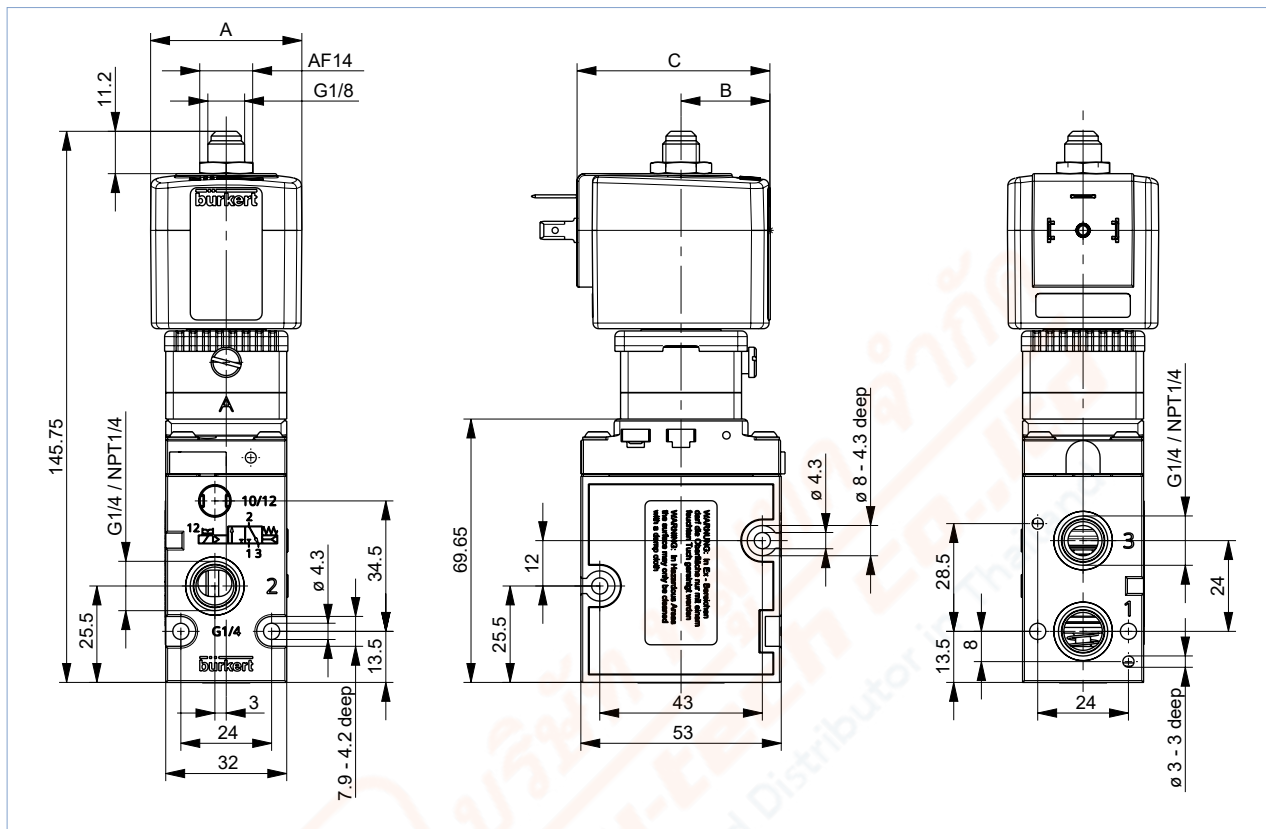

DTS 1000011064 EN Version: B Status: RL (released | freigegeben | valide) printed: 15.02.2023

5.5. ATEX version cable coil and terminal box

Note:

Dimensions in mm

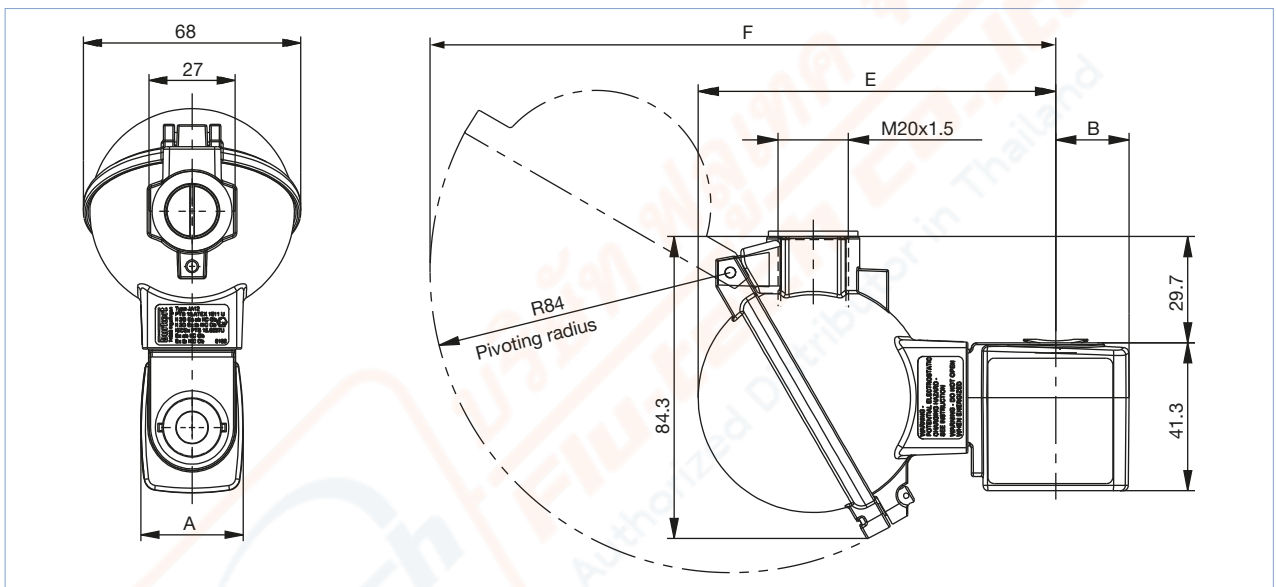
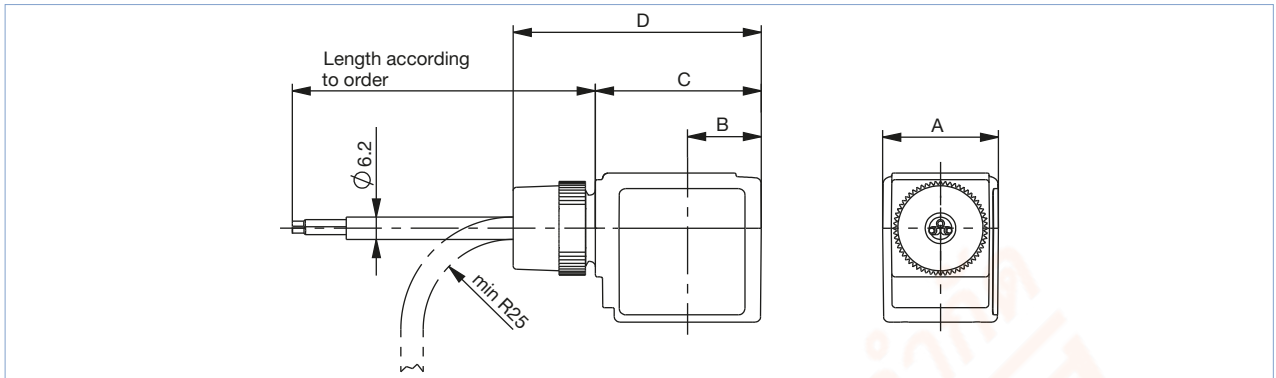

Coil size	A	B	C	D	E	F
5	32	20.5	46	66.8	99.8	174.7
6	40	23.5	52	74.8	102.8	177.7

DTS 1000011064 EN Version: B Status: RL (released | freigegeben | valide) printed: 15.02.2023

6. Product design and assembly

6.1. Block construction

Note:

Single modules or pre-mounted blocks are available.

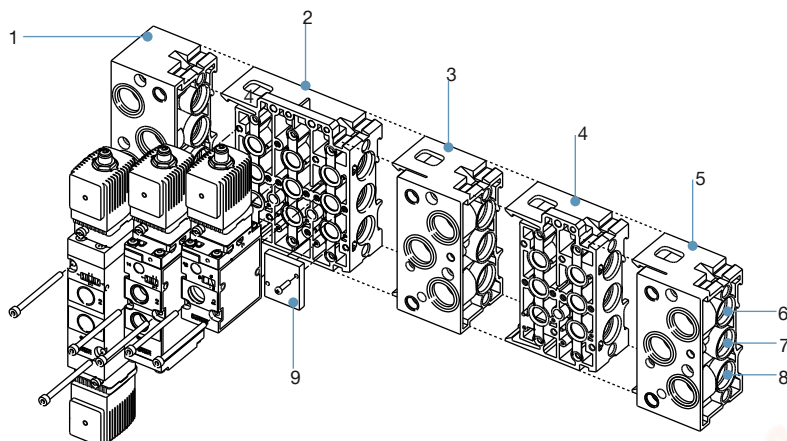

No.	Element
1	Connector module left
2	Basic module 3-fold
3	intermediate supply module: supply channel pushed through for additional pressure supply or Connector module, right: supply channel closed off, there by several operational pressures possible in a single block
4	Basic module 2-fold
5	Connector module right
6	Supply port: 3(R)
7	Supply port: 1(P)
8	Supply port: 5(S)
9	Covering plate for 3/2-way valve (to cover unused connections)

Note:

Valves with Ex i coil or Ex versions with terminal boxes are not suitable for block mounting.

Ordering example Type 6518 with pneumatic module Type MP07		
Unit	Version	Article no.
1	Connector module right, G ½	635331
1	Basic module 2-fold universal (for 3/2-, 5/2- and 5/3-way)	635319
1	Basic module 3-fold universal (for 3/2-, 5/2- and 5/3-way)	635343
1	Connector module left, G ½	635324
5	Valves 6518	132475



Version	Article no.
Connector module right, G ½	635331
Intermediate supply module	637505
Basic module 2-fold universal (for 3/2-, 5/2- and 5/3-way)	635319
Basic module 3-fold universal (for 3/2-, 5/2- and 5/3-way)	635343
Connector module left, G ½	635324
Covering plate for 5/2-way and 5/3-way (to cover unused valve positions)	635335
Covering plate for 3/2-way (to cover unused connections)	635337

7. Product accessories

7.1. Cable glands for ATEX/IECEX terminal box

Note:

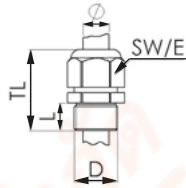
A cable gland in polyamide version is included in the delivery. A nickel-plated brass version can be ordered at a surcharge, see “Cable glands for ATEX/IECEX terminal box” on page 21.

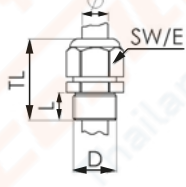
Description	Ex approvals		Dimensions										
	Certification	Identification											
Ex cable gland, Brass, nickel-plated, 6...13 mm 	PTB 04 ATEX 1112 X, IECEX PTB 13.0027X	II 2 G Ex e IIC Gb, II 2 D Ex tb IIIC Db IP68	 <table border="1"> <tr><td>TL</td><td>29...37 mm</td></tr> <tr><td>L</td><td>6 mm</td></tr> <tr><td>D</td><td>20 mm</td></tr> <tr><td>SW</td><td>24 mm</td></tr> <tr><td>E</td><td>27 mm</td></tr> </table>	TL	29...37 mm	L	6 mm	D	20 mm	SW	24 mm	E	27 mm
TL	29...37 mm												
L	6 mm												
D	20 mm												
SW	24 mm												
E	27 mm												
Ex cable gland, Polyamide, 7...13 mm 	PTB 13 ATEX 1015 X, IECEX PTB 13.0034X	II 2 G Ex e IIC Gb, II 2 D Ex tb IIIC Db IP68	 <table border="1"> <tr><td>TL</td><td>36...45 mm</td></tr> <tr><td>L</td><td>10 mm</td></tr> <tr><td>D</td><td>20 mm</td></tr> <tr><td>SW</td><td>24 mm</td></tr> <tr><td>E</td><td>28 mm</td></tr> </table>	TL	36...45 mm	L	10 mm	D	20 mm	SW	24 mm	E	28 mm
TL	36...45 mm												
L	10 mm												
D	20 mm												
SW	24 mm												
E	28 mm												

7.2. Special tool to turn the terminal box

Note:

- This special tool is not supplied with the valve, see “Cable glands for ATEX/IECEX terminal box” on page 21.
- This special tool can only be used with ATEX AC10 coils.

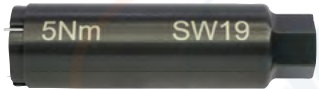
Description	Components of the set
Set SC02-AC10 	<ul style="list-style-type: none"> • Special wrench • Service manual

DTS 1000011064 EN Version: B Status: RL (released | freigegeben | validé) printed: 15.02.2023

8. Ordering information

8.1. Bürkert eShop – Easy ordering and quick delivery



Bürkert eShop – Easy ordering and fast delivery

You want to find your desired Bürkert product or spare part quickly and order directly? Our online shop is available for you 24/7. Sign up and enjoy all the benefits.

[Order online now](#)

8.2. Bürkert product filter

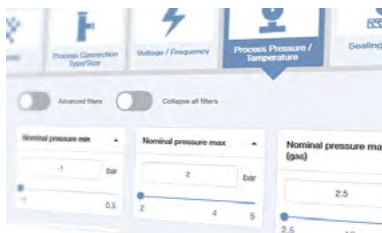

Bürkert product filter – Get quickly to the right product

You want to select products comfortably based on your technical requirements? Use the Bürkert product filter and find suitable articles for your application quickly and easily.

[Try out our product filter](#)

8.3. Ordering chart

Standard version with plug form A

Note:

- Please note that the cable plug must be ordered separately.
- See “Cable plug Type 2513, form A according to DIN EN 175301 -803” on page 19 or separate data sheet for **Type 2513** ▶.
- See “Cable plug Type 2518, form A according to DIN EN 175301 -803” on page 19 or separate data sheet for **Type 2518** ▶.
- Further variants without manual override available on request.

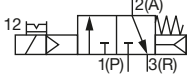
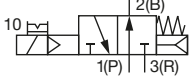
Circuit function	Orifice [mm]	Seal material Body	Q _{N₀} -value air ¹⁾ [l/min]	Pressure range ²⁾ [bar]	Electrical connection	Nominal power [W]	Voltage/ Frequency [V/Hz]	Article no.	
								G¼	NPT¼
Type C, solenoid valve 3/2-way Servo-controlled, with manual override Normally closed 	8.0	NBR and PUR (Polyamide)	1300	2...10	Form A	2	024/DC	132457	132725
							024/50...60	132458	X
							110/50...60	132459	X
							230/50...60	132460	X
Type D, solenoid valve 3/2-way Servo-controlled, with manual override Normally opened 	8.0	NBR and PUR (Polyamide)	1300	2...10	Form A	2	024/DC	132461	X
							024/50...60	132462	X
							110/50...60	132463	X
							230/50...60	132464	X

1.) Measurement at 6 bar and +20 °C at valve inlet and 1 bar pressure difference

2.) Pressure data: Overpressure to atmospheric pressure

X: on request

Standard version with plug form B
Note:

- Please note that the cable plug must be ordered separately.
- See “[Cable plug Type 2507, form B according to industry standard](#)” on page 20 or separate data sheet for **Type 2507** ▶.
- Further variants without manual override available on request.

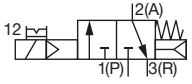
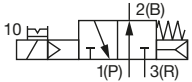
Circuit function	Orifice	Seal material	Q _{Nm} -value	Pressure	Electrical connection	Nominal power	Voltage/ Frequency	Article no.	
	[mm]	Body	[l/min] ¹⁾	[bar] ²⁾				G ¹ / ₄	NPT ¹ / ₄
Type C, solenoid valve 3/2-way Servo-controlled, with manual override Normally closed 	8.0	NBR and PUR (Polyamide)	1300	2...10	Form B	2	024/DC	X	X
Type D, solenoid valve 3/2-way Servo-controlled, with manual override Normally opened 	8.0	NBR and PUR (Polyamide)	1300	2...10	Form B	2	024/DC	X	X

1.) Measurement at 6 bar and +20 °C at valve inlet and 1 bar pressure difference

2.) Pressure data: Overpressure to atmospheric pressure

X: on request

Standard version with plug form C

Note:

- Please note that the cable plug must be ordered separately.
- See “Cable plug Type 2516, form C according to DIN EN 175301 - 803” on page 20 or separate data sheet for Type 2516 ▶.
- Further variants without manual override available on request.

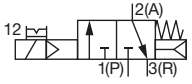
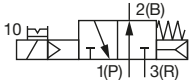
Circuit function	Orifice	Seal material Body	Q _{Nn} -value air ¹⁾	Pressure range ²⁾	Electrical connection	Nominal power	Voltage/ Frequency	Article no.	
	[mm]							G ¹ / ₄	NPT ¹ / ₄
Type: C, solenoid valve 3/2-way Servo-controlled, with manual override Normally closed 	8.0	NBR and PUR (Polyamide)	1300	2...10	Form C	2	024/DC	X	X
Type: D, solenoid valve 3/2-way Servo-controlled, with manual override Normally opened 	8.0	NBR and PUR (Polyamide)	1300	2...10	Form C	2	024/DC	X	X

1.) Measurement at 6 bar and +20 °C at valve inlet and 1 bar pressure difference

2.) Pressure data: Overpressure to atmospheric pressure

X: on request

Ex mb version (with moulded cable)

Note:

Further variants without manual override available on request.

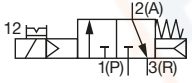
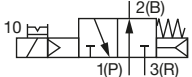
Circuit function	Orifice	Seal material Body	Q _{Nn} -value air ¹⁾	Pressure range ²⁾	Nominal power	Voltage/ Frequency	Article no.	
	[mm]						G ¹ / ₄	NPT ¹ / ₄
Type: C, solenoid valve 3/2-way Servo-controlled, with manual override Normally closed 	8.0	NBR and PUR (Polyamide)	1300	2...10	3	024/UC	350443 ☒	X
						110/UC	350449 ☒	X
						230/UC	350451 ☒	X
Type: D, solenoid valve 3/2-way Servo-controlled, with manual override Normally opened 	8.0	NBR and PUR (Polyamide)	1300	2...10	3	024/UC	350452 ☒	X
						110/UC	X	X
						230/UC	X	X

1.) Measurement at 6 bar and +20 °C at valve inlet and 1 bar pressure difference

2.) Pressure data: Overpressure to atmospheric pressure

X: on request

Visit product website ▶

17 | 22

Ex eb mb version (with terminal box)

Note:

Further variants without manual override available on request.

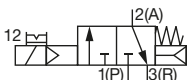
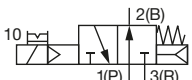
Circuit function	Orifice [mm]	Seal material Body	Q _{Nn} -value air ¹⁾ [l/min]	Pressure range ²⁾ [bar]	Nominal power [W]	Voltage/ Frequency [V/Hz]	Article no.	
							G ¹ / ₄	NPT ¹ / ₄
Type: C, solenoid valve 3/2-way Servo-controlled, with manual override Normally closed 	8.0	NBR and PUR (Polyamide)	1300	2...10	3	024/UC	350446 ☒	X
						110/UC	350450 ☒	X
						230/UC	368752 ☒	X
Type: D, solenoid valve 3/2-way Servo-controlled, with manual override Normally opened 	8.0	NBR and PUR (Polyamide)	1300	2...10	3	024/UC	X	X
						110/UC	20009771 ☒	X
						230/UC	20015790 ☒	X

1.) Measurement at 6 bar and +20 °C at valve inlet and 1 bar pressure difference

2.) Pressure data: Overpressure to atmospheric pressure

X: on request

Ex i version (310 Ohm)

Note:

- Please note that the cable plug must be ordered separately, see **“Cable plug Type 2518, form A according to DIN EN 175301-803” on page 19** or separate data sheet for **Type 2518** ▶.
- Further variants with manual override available on request.
- Further variants with 481 Ohm available on request.

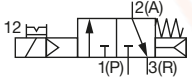
Circuit function	Orifice [mm]	Seal material Body	Q _{Nn} -value air ¹⁾ [l/min]	Pressure range ²⁾ [bar]	Body material pilot valve	Material threaded bushing Material threaded bushing	Article no.	
							G ¹ / ₄	NPT ¹ / ₄
Type: C, solenoid valve 3/2-way Servo-controlled, with manual override Normally closed 	8.0	NBR and PUR (Polyamide)	1300	2...10	Stainless steel 1.4305	Stainless steel	20000908 ☒	20000931 ☒
						Brass, nickel plated	20000913 ☒	X

1.) Measurement at 6 bar and +20 °C at valve inlet and 1 bar pressure difference

2.) Pressure data: Overpressure to atmospheric pressure





X: on request

8.4. Ordering chart accessories

Cable plug Type 2513, form A according to DIN EN 175301 - 803

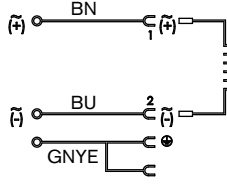
Note:





- Cable plug Type 2513 meets the requirements of ATEX category 3 GD when assembled with a Bürkert solenoid valve.
- For more information on the cable plug, see data sheet **Type 2513** ▶.

Cable plug	Circuit diagram	Cable length [mm]	Article no.
		12000	260893 
		5000	260892 
		3000	260891 
		300	260890 

Cable plug Type 2518, form A according to DIN EN 175301 - 803

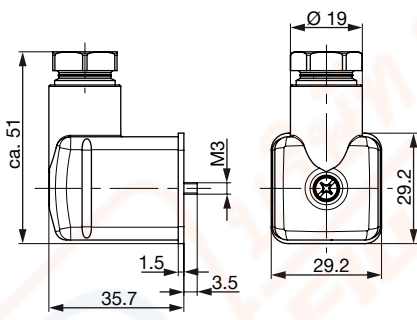
Note:

For further versions see data sheet **Type 2518** ▶.

Cable plug	Dimensions	Version	Voltage	Article no.
		Without circuitry (AC/DC)	0...250 V AC/DC	314802 
		With LED (AC/DC)	12...24 V AC/DC	314812 
		With LED and varistor (AC/DC)	12...24 V AC/DC	314820 
		With rectifier, LED and varistor	12...24 V AC/DC	314816 

Cable plug Type 2507, form B according to industry standard

Note:

- Delivery of cable plug includes a flat seal and a fixing screw.
- For further versions see data sheet **Type 2507** ▶.

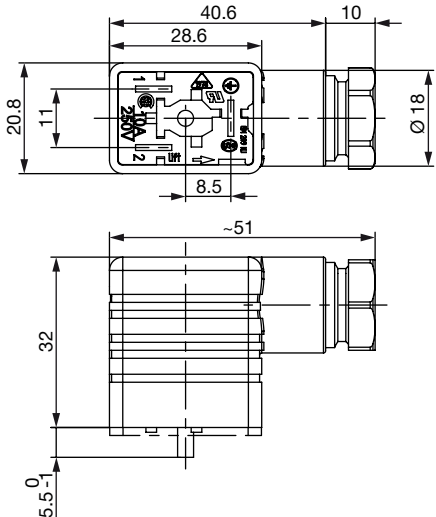
Cable plug	Dimensions	Version	Voltage	Article no.
		Without circuitry (standard)	2...250 V AC/DC	423845 ☒
		With LED	24 V AC/DC	423849 ☒
		With LED and free-wheeling diode	12...24 V AC/DC	423851 ☒
		With rectifier, LED and varistor	12...24 V AC/DC	423853 ☒

Cable plug Type 2516, form C according to DIN EN 175301-803

Note:

- Delivery of cable plug includes a flat seal and a fixing screw.
- For further versions see data sheet **Type 2516** ▶.

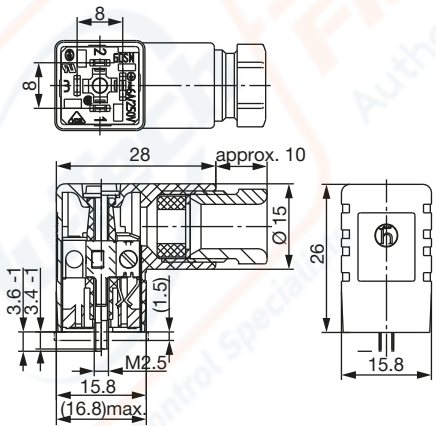
Cable plug	Dimensions	Version	Voltage	Article no.
		Without circuitry	0...250 V AC/DC	303141 ☒
		With LED	12...24 V AC/DC	303145 ☒
		With LED and varistor	12...24 V AC/DC	303148 ☒
		With rectifier, LED and varistor	12...24 V AC/DC	303142 ☒

DTS 1000011064 EN Version: B Status: RL (released | freigegeben | valide) printed: 15.02.2023

Cable glands for ATEX/IECEX terminal box

Note:

- A cable gland in polyamide version is included in the delivery. A nickel-plated brass version can be ordered at surcharge.
- For more information on Ex cable glands, see “7.1. Cable glands for ATEX/IECEX terminal box” on page 13.
- For more information on Special wrench see “7.2. Special tool to turn the terminal box” on page 13.

Description	Article no.
Ex cable gland, brass, nickelplated, 6...13 mm ^{1.)}	773278 ☒
Ex cable gland, polyamide, 7...13 mm ^{1.)}	773277 ☒
Set SC02-AC10: Special wrench ^{2.)} incl. service manual	293488 ☒

1.) Cable diameter

2.) Not included in the scope of delivery of the valve