



Direct-acting 2/2-way plunger valve

- Direct-acting and compact small valve up to DN 2.4
- Slipped over coil system
- Simple and fast flange or manifold mounting
- Quick coupling (push-in fitting) for push-in connectors
- Explosion-proof variants

Product variants described in the data sheet may differ from the product presentation and description.

Type description

The 7011 valve is a direct-acting plunger valve. The stopper and the core guide tube are welded together to increase pressure resistance and leak-tightness. Various housing and seal material combinations are available depending on the actual application. A Bürkert-specific flange variant (SFB) enables the space-saving arrangement of valves on a multiple manifold. The range is supplemented by variants conforming to DVGW EN 161 and explosion-proof variants. Push-in fittings can be selected for a flexible hose connection. In combination with a plug conforming to DIN EN 175301-803 shape B, the valves satisfy degree of protection IP65.

Table of contents

1. General technical data	3
2. Product versions	4
2.1. DVGW version.....	4
3. Circuit functions	4
4. Approvals	4
5. Materials	5
5.1. Chemical Resistance Chart – Bürkert resistApp.....	5
5.2. Material specifications	5
Standard version circuit function A.....	5
Standard version circuit function B	6
ATEX/IECEX cable version	7
6. Dimensions	8
6.1. Standard version.....	8
Threaded version	8
Flange version.....	8
6.2. ATEX-/IECEX cable version.....	9
Threaded version	9
Flange version.....	10
6.3. Solenoid coil dimensions.....	11
Further electrical connections.....	11
PIN Assignments	12
Pin assignment vacuum applications	12
6.4. Multiple manifold	13
7. Performance specifications	14
7.1. Power consumption	14
Standard coil version 24.5 mm.....	14
Coil version 20 mm.....	15
8. Ordering information	15
8.1. Bürkert eShop – Easy ordering and quick delivery.....	15
8.2. Bürkert product filter.....	16
8.3. Ordering chart.....	16
Standard version according to industry standard Form B, coil size 24.5 mm.....	16
DVGW version.....	19
ATEX/IECEX version.....	20
Standard version according to industry standard Form B, coil size 20 mm.....	20
Additional options.....	23
8.4. Ordering chart accessories.....	23
Accessories for manifolds	23
Cable plug Type 2516 acc. to DIN EN 175301-803 Form C	23
Cable plug Type 2507 acc. to industry standard Form B	23

1. General technical data

Product properties	
Dimensions	Detailed information can be found in chapter "6. Dimensions" on page 8.
Material	
Body	Brass, polyamide (PA), stainless steel 1.4305
Seal	FKM, EPDM
Weight	
Standard version 24.5 mm solenoid coil	146 g (with G 1/8)
Standard version 20 mm solenoid coil	120 g (with G 1/8)
Manual override	Optional
Circuit function	A and B Detailed information can be found in chapter "3. Circuit functions" on page 4.
Thermal insulation class of solenoid	Epoxy: class H
Performance data	
Nominal operating mode	
Single valve	Continuous operation 100 % ED resp. 50 % ED
For block mounting on multiple manifold	With 4 W/5 W solenoid coil 100 % ED (at max. 55 °C)
Switching time ^{1.)} standard version	Orifice 1.2...2.4 mm: opening 8...15 ms, closing 10...17 ms
Electrical data	
Operating voltage	24 V DC, 24 V / 50 Hz, 230 V / 50 Hz
Voltage tolerance	± 10 %
Medium data	
Operating medium	Neutral gases and fluids (e.g. compressed air, water, hydraulic oil, technical vacuum)
Medium temperature standard version	- 10 °C...+ 100 °C
Viscosity (max.)	21 mm ² /s
Process/Port connection & communication	
Electrical connection	<ul style="list-style-type: none"> • Acc. to DIN EN 175301 - 803 Form C for cable plug Type 2516 • Acc. to industry standard Form B for cable plug Type 2507 • Flat pin terminal as protection class III device • Flying leads connection on request for coil size 20 mm • ATEX/IECEX version with 3 m moulded-in cable
Port connection standard version	M5, G 1/8, flange
Approvals and certificates	
Degree of protection	IP65 with cable plug and ATEX/IECEX cable connection version
Environment and installation	
Installation position	As required, preferably with actuator upright
Ambient temperature	
Standard version	Max. +55 °C resp. 75 °C, depending on power level
ATEX/IECEX version	Max. +55 °C (max. +60 °C on request)

1.) Measured at valve outlet at 6 bar and +20 °C according to ISO 12238, opening: pressure rise 0...10 %, closing: pressure drop 100...90 %

2. Product versions

2.1. DVGW version

The solenoid valve Type 7011 DVGW is preferably intended as an automatic safety shut-off valve for flammable gases. A filter is installed in the inlet of the valve.

Product properties	
Material	
Body	Brass, stainless steel 1.4305
Seal	NBR
Circuit function	A
Performance data	
Operating pressure (max.)	42 bar
Medium data	
Medium	Flammable gases such as town gas, district gas, liquid gas, hydrogen (see "5.1. Chemical Resistance Chart – Bürkert resistApp" on page 5)
Medium temperature	-20 °C...+80 °C
Approvals and certificates	
Standards	DIN EN 161:2016; DIN EN 16678:2016
Environment and installation	
Ambient temperature	-20 °C...+55 °C

3. Circuit functions

Circuit functions	Description
	Type: A, solenoid valve 2/2 way Direct-acting Normally closed
	Type: B, solenoid valve 2/2 way Direct-acting Normally open

4. Approvals

Approvals	Description
	ATEX and IECEx approval for coils with fixed cable outlet ATEX: EPS 21 ATEX 1 128 X II 2G Ex mb IIC T4 Gb II 2D Ex mb IIIC T130 °C Db IECEx: IECEx EPS 21.0045X Ex mb IIC T4 Gb Ex mb IIIC T130 °C Db

5. Materials

5.1. Chemical Resistance Chart – Bürkert resistApp

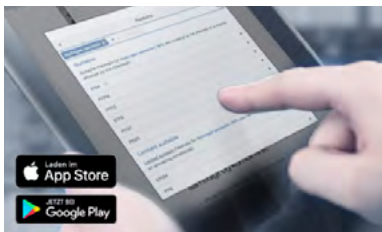

Bürkert resistApp – Chemical Resistance Chart

You want to ensure the reliability and durability of the materials in your individual application case? Verify your combination of media and materials on our website or in our resistApp.

[Start Chemical Resistance Check](#)

5.2. Material specifications

Standard version circuit function A

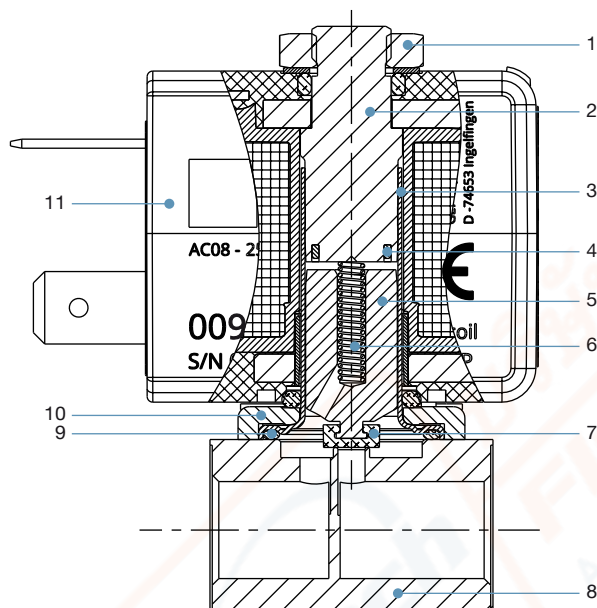

No.	Element	Material
1	Locknut	DIN 176 Surface finish thick film passivated KOSA0101
2	Stopper	Stainless steel 1.4113
3	Guide tube	Stainless steel 1.4303 ST
4	Shading ring	Copper, (optional silver)
5	Core	Stainless steel 1.4113
6	Spring	Stainless steel 1.4310
7	Seal	FKM/EPDM
8	Valve body	Brass, stainless steel 1.4305 PA (polyamide)
9	O-Ring	FKM/EPDM
10	Flange	<ul style="list-style-type: none"> • Surface finish thick film passivated KOSA0101 (brass version) • Nickel-plated surface (stainless steel version)
11	Coil	Epoxy

DTS 1000446515 EN Version: F Status: RL (released | freigegeben | validé) printed: 17.03.2022

Standard version circuit function B

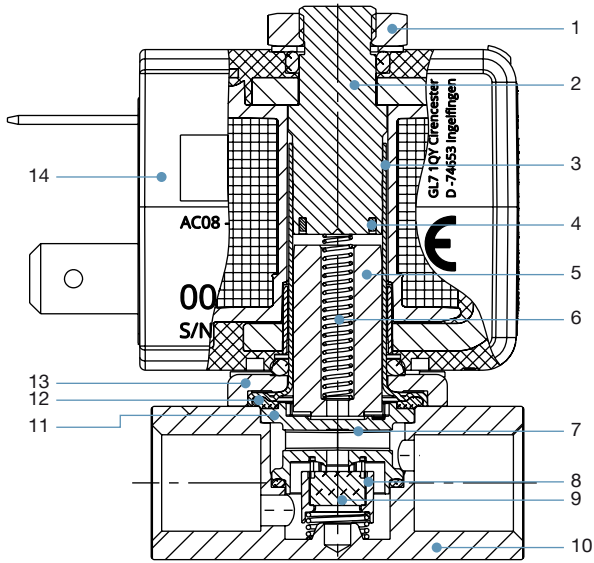

No.	Element	Material
1	Locknut	DIN 176 Surface finish thick film passivated KOSA0101
2	Stopper	Stainless steel 1.4113
3	Guide tube	Stainless steel 1.4303 ST
4	Shading ring	Copper, (optional silver)
5	Core	Stainless steel 1.4113
6	Spring	Stainless steel 1.4310
7	Insert	PEEK GF30
8	Seal holder	PEEK GF30
9	Seat seal	FKM
10	Valve body	Brass, stainless steel 1.4305 PA (polyamide)
11	Seal	FKM/EPDM
12	O-Ring	FKM/EPDM
13	Flange	<ul style="list-style-type: none"> Surface finish thick film passivated KOSA0101 (brass version) Nickel-plated surface (stainless steel version)
14	Coil	Epoxy

DTS 1000446515 EN Version: F Status: RL (released | freigegeben | valide) printed: 17.03.2022

ATEX/IECEx cable version

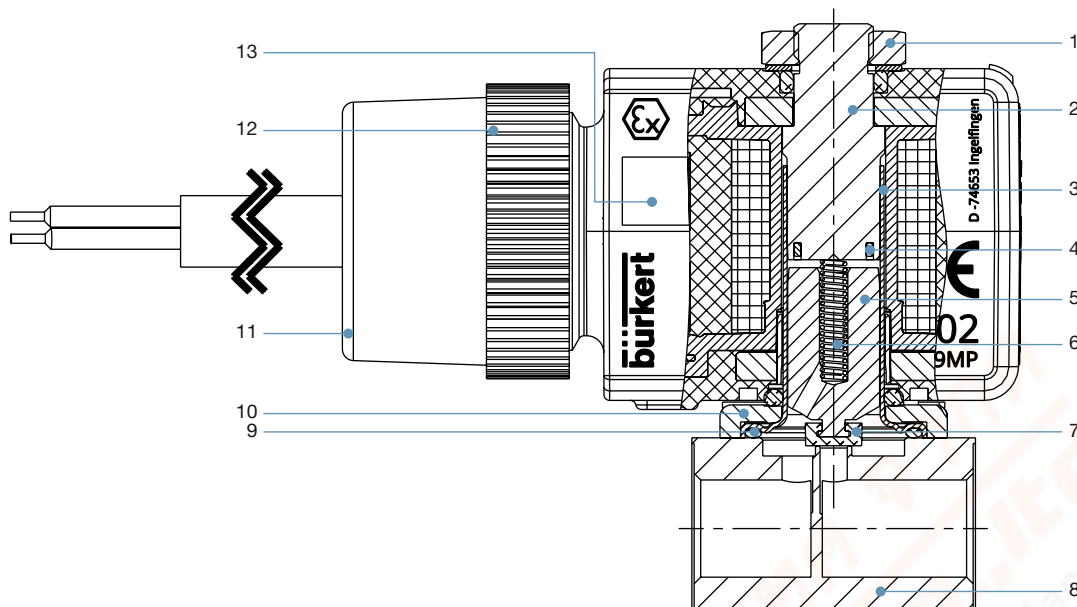

No.	Element	Material
1	Locknut	DIN 176 Surface finish thick film passivated KOSA0101
2	Stopper	Stainless steel 1.4113
3	Guide tube	Stainless steel 1.4303 ST
4	Shading ring	Copper, (optional silver)
5	Core	Stainless steel 1.4113
6	Spring	Stainless steel 1.4310
7	Seal	FKM/EPDM
8	Valve body	Brass, stainless steel 1.4305 PA (polyamide)
9	O-Ring	FKM/EPDM
10	Flange	<ul style="list-style-type: none"> Surface finish thick film passivated KOSA0101 (brass version) Nickel-plated surface (stainless steel version)
11	Sealing ring	Silicone
12	Union nut	PA (Polyamide)
13	Coil	Epoxy

DTS 1000446515 EN Version: F Status: RL (released | freigegeben | valide) printed: 17.03.2022

6. Dimensions

6.1. Standard version

Threaded version

Note:

- Dimensions in mm
- Versions according to industry standard Form B

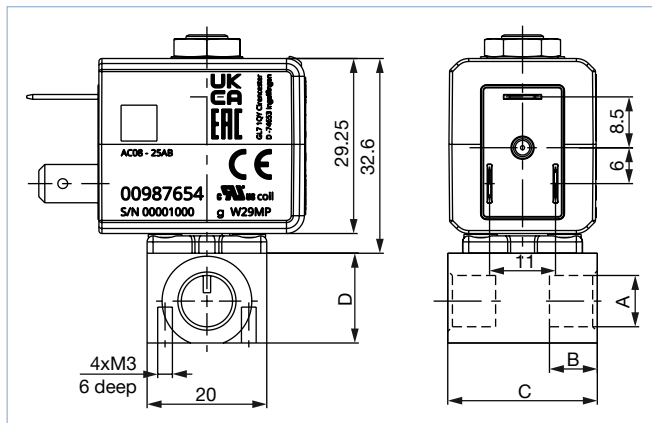

Port connection	A	B	C	D
Thread WWA	M5	5	20	10
	G 1/8	8	25	15
Thread WWB	G 1/8	8	34	14

Flange version

Note:

- Dimensions in mm
- Versions according to industry standard Form B

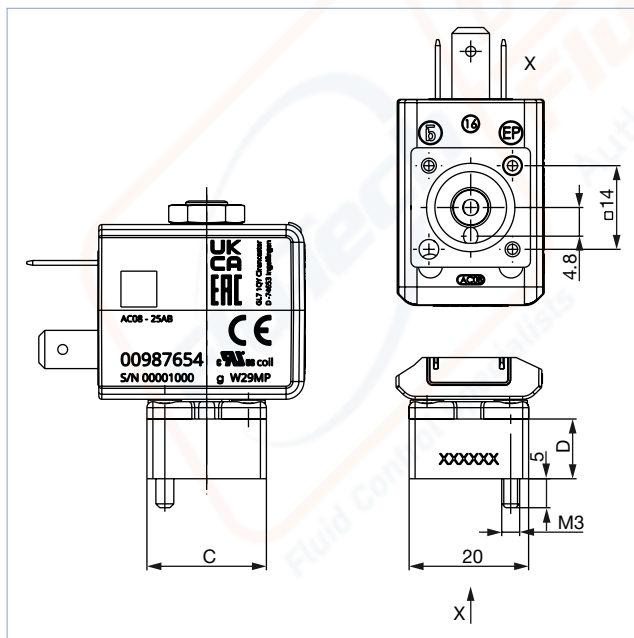

Port connection	A	B	C	D
Flange WWA	-	-	20	10
Flange WWB	-	-	25	15

DTS 1000446515 EN Version: F Status: RL (released | freigegeben | valide) printed: 17.03.2022

6.2. ATEX-/IECEx cable version

Threaded version

Note:

Dimensions in mm

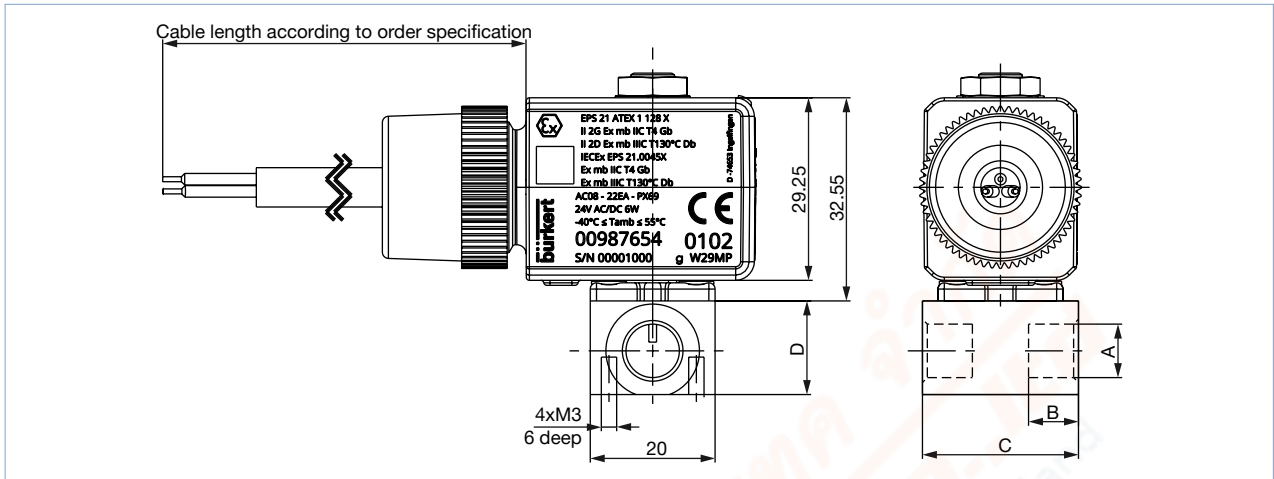

Port connection	A	B	C	D
Thread	M5	5	20	10
Thread	G 1/8	8	25	15

DTS 1000446515 EN Version: F Status: RL (released | freigegeben | valide) printed: 17.03.2022

Flange version

Note:

Dimensions in mm

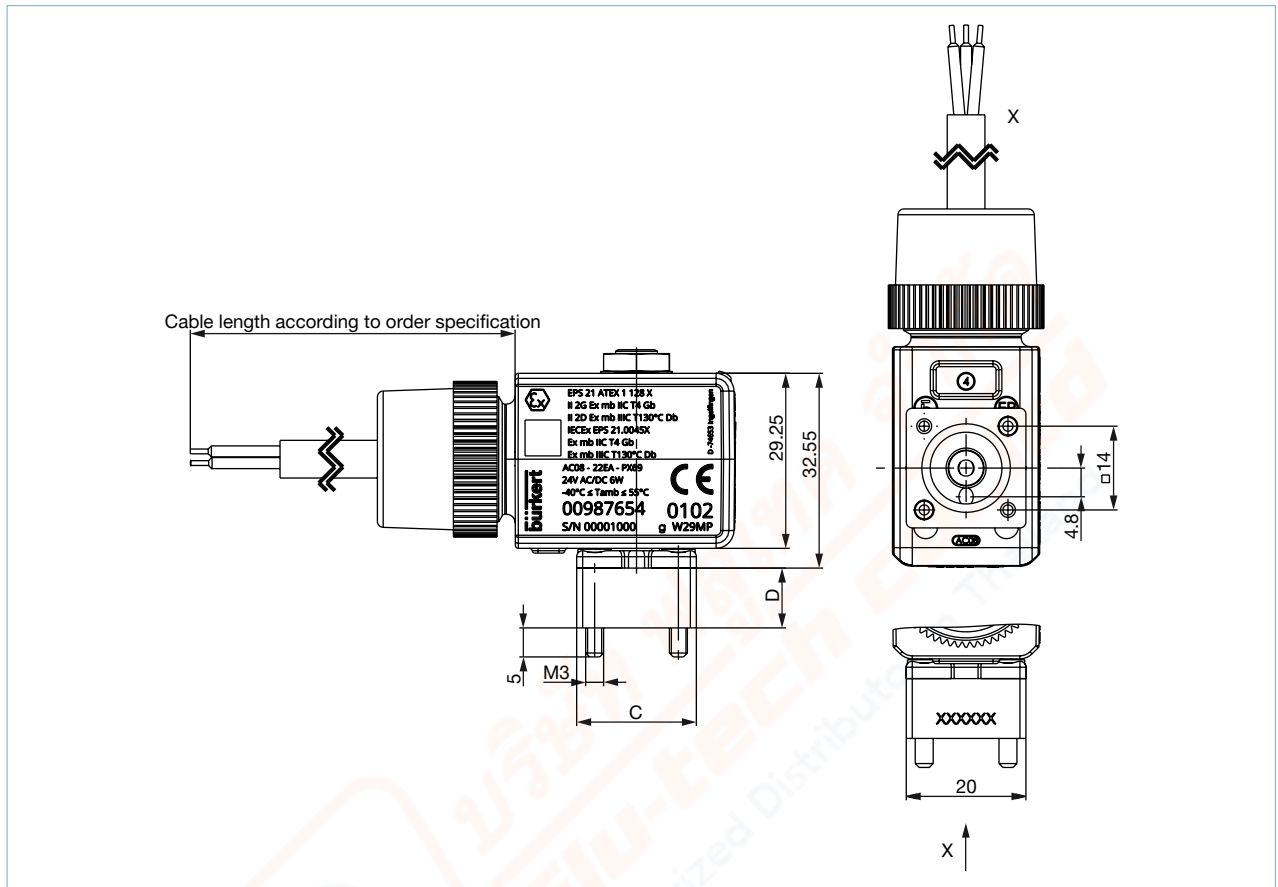

Port connection	A	B	C	D
Flange WWA	-	-	20	11
Flange WWB	-	-	25	15

6.3. Solenoid coil dimensions

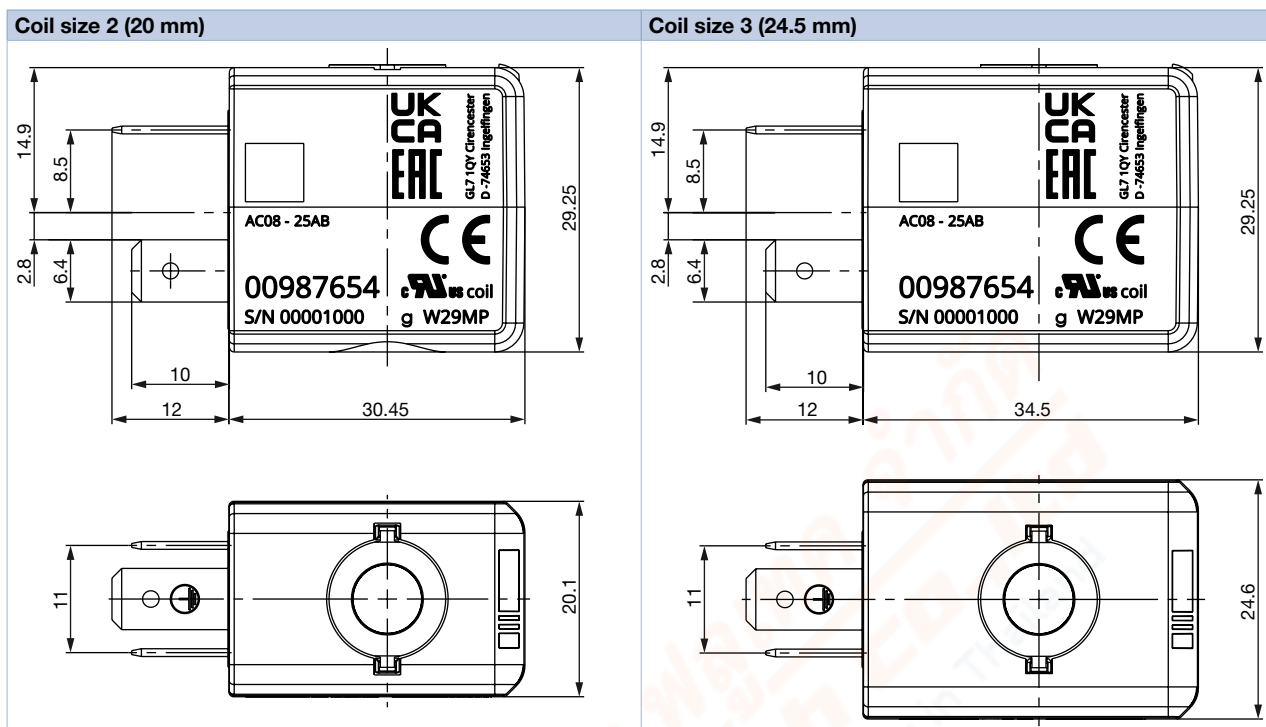

Further electrical connections

Note:

- Specifications apply to coil sizes 20 mm and 24.5 mm
- Dimensions in mm

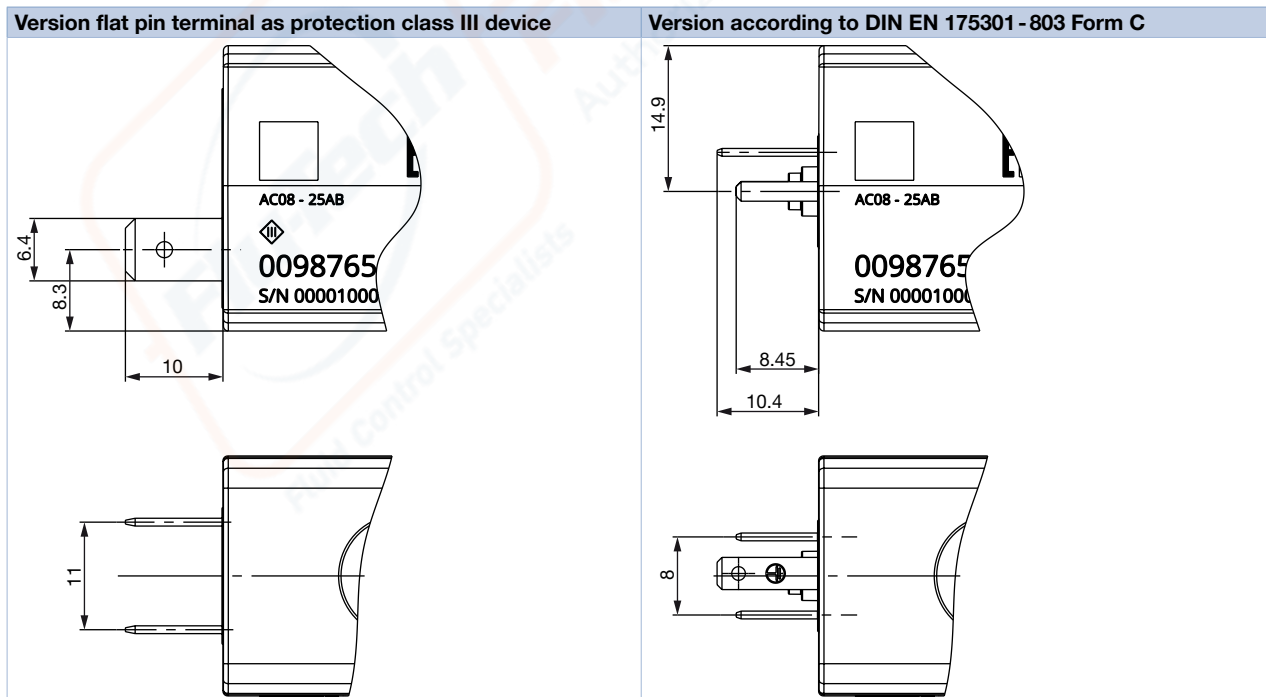

PIN Assignments

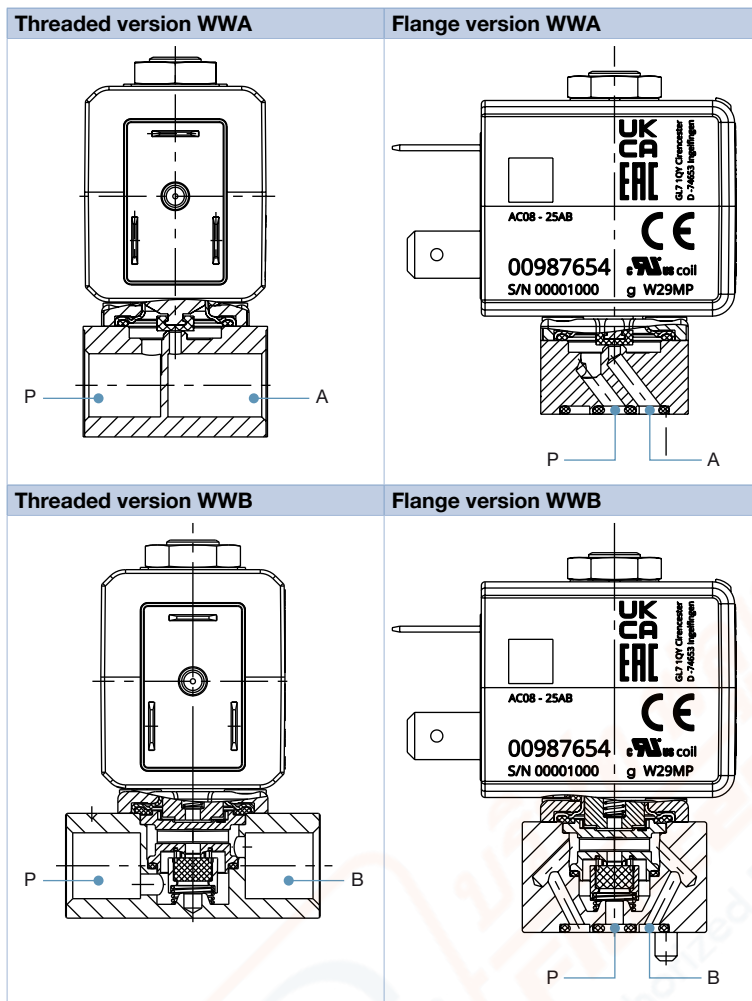

Pin assignment vacuum applications

In vacuum applications the existing flow direction must be maintained. Vacuum must therefore always be applied to A.
(Other terminal assignment on request)

6.4. Multiple manifold

Note:

- Dimensions in mm
- Can only be combined with valves with coil size 20 mm
- Manifolds with valves of coil size 24.5 mm on request

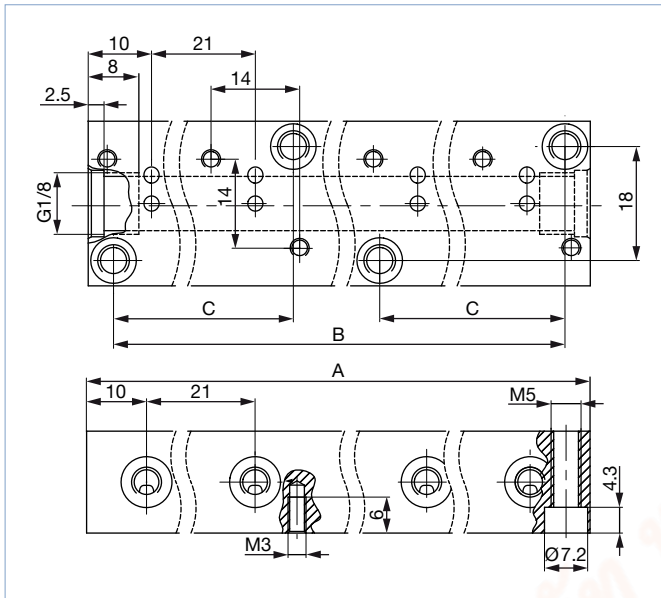

Quantity of valve places	A [mm]	B [mm]	C [mm]	Article no.
1	20	12	–	005312
2	41	33	–	005355
3	62	54	–	005313
4	83	75	–	005314
5	104	96	–	005315
6	125	117	–	005316
7	146	138	–	005893
8	167	159	54	005166
9	188	180	54	005241
10	209	201	75	005819
11	230	222	75	005242
12	251	243	96	005222

DTS 1000446515 EN Version: F Status: RL (released | freigegeben | validé) printed: 17.03.2022

7. Performance specifications

7.1. Power consumption

Standard coil version 24.5 mm

Coil	Orifice [mm]	Electrical power					Switching times ^{1.)}		
		Inrush AC		Hold AC		DC		Opening [ms]	Closing [ms]
		[VA]	[VA]	[W]	Cold [W]	Hot [W]			
24 V / DC / 7 W	1.2	–	–	–	7	5.5	8...15	10...17	
	1.6								
	2.0								
	2.4								
24 V / 50 Hz / 6 W	1.2	14	8	6	–	–			
	1.6								
	2.0								
	2.4								
230 V / 50 Hz / 6 W	1.2	14	8	6	–	–			
	1.6								
	2.0								
	2.4								
24 V / DC / 5.5 W	1.2	–	–	–	5.5	4.5			
	1.6								
	2.0								
	2.4								
24 V / 50 Hz / 4 W	1.2	12	6.5	4	–	–			
	1.6								
	2.0								
	2.4								
230 V / 50 Hz / 4 W	1.2	12	6.5	4	–	–			
	1.6								
	2.0								
	2.4								
24 V / DC / 14 W	1.2	–	–	–	14	11			
	1.6								
	2.0								
	2.4								
24 V / DC / 11 W	1.2	–	–	–	11	8.5			
	1.6								
	2.0								
	2.4								

1.) Measured at valve outlet at 6 bar^{2.)} and +20 °C according to ISO 12238, opening: pressure rise 0...10 %, closing: pressure drop 100...90 %

2.) Measured as overpressure to the atmospheric pressure and air as a medium

Coil version 20 mm

Coil	Orifice [mm]	Electrical power					Switching times ¹⁾	
		Inrush AC [VA]	Hold AC [VA] [W]		DC Cold [W] Hot [W]		Opening [ms]	Closing [ms]
24 V / DC / 6.5 W	1.2	–	–	–	6.5	5	8...15	10...17
	1.6							
	2.0							
	2.4							
24 V / 50 Hz / 6 W	1.2	11	7	6	–	–		
	1.6							
	2.0							
	2.4							
230 V / 50 Hz / 6 W	1.2	11	7	6	–	–		
	1.6							
	2.0							
	2.4							
24 V / DC / 5 W	1.2	–	–	–	5	4		
	1.6							
	2.0							
	2.4							
24 V / 50 Hz / 4 W	1.2	9	5	4	–	–		
	1.6							
	2.0							
	2.4							
230 V / 50 Hz / 4 W	1.2	9	5	4	–	–		
	1.6							
	2.0							
	2.4							
24 V / DC / 14 W	1.2	–	–	–	14	11		
	1.6							
	2.0							
	2.4							
24 V / DC / 11 W	1.2	–	–	–	11	9		
	1.6							
	2.0							
	2.4							

1.) Measured at valve outlet at 6 bar²⁾ and +20 °C according to ISO 12238, opening: pressure rise 0...10%, closing: pressure drop 100...90%

2.) Measured as overpressure to the atmospheric pressure and air as a medium

8. Ordering information

8.1. Bürkert eShop – Easy ordering and quick delivery



Bürkert eShop – Easy ordering and fast delivery

You want to find your desired Bürkert product or spare part quickly and order directly? Our online shop is available for you 24/7. Sign up and enjoy all the benefits.

[Order online now](#)

8.2. Bürkert product filter



Bürkert product filter – Get quickly to the right product

You want to select products comfortably based on your technical requirements? Use the Bürkert product filter and find suitable articles for your application quickly and easily.

Try out our product filter

8.3. Ordering chart

Standard version according to industry standard Form B, coil size 24.5 mm

Note:

All valves without cable plug

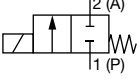
Circuit function	Port connection	Orifice [mm]	K _v value H ₂ O ¹⁾ [m ³ /h]	Voltage/ Frequency/Power [V/Hz/W]	Maximum duty cycle	Medium pressure [bar] ^{2) 3)}				Article no. Body material Brass	Article no. Body material stainless steel			
						Ambient temperature 75 °C		Ambient temperature 55 °C						
						Air	Water	Air	Water					
A, solenoid valve 2/2 way Direct-acting Normally closed 	M5	1.2	0.045	24 V / DC / 7 W	100 % ED	–	–	0...23	0...23	380543	389721			
				24 V / 50 Hz / 6 W		–	–	0...45	0...45	389723	389726			
				230 V / 50 Hz / 6 W		–	–	0...45	0...45	389738	389739			
				24 V / DC / 5.5 W		0...16	0...16	–	–	389740	389742			
				24 V / DC / 5.5 W		–	–	0...19	0...19	X	X			
				24 V / 50 Hz / 4 W		0...42	0...42	0...42	0...42	389744	389746			
				230 V / 50 Hz / 4 W		0...42	0...42	0...42	0...42	389751	389750			
				24 V / DC / 14 W		50 % ED	–	–	0...45	0...45	X	X		
				24 V / DC / 11 W			0...35	0...35	–	–	X	X		
				24 V / DC / 11 W			–	–	0...37	0...37	X	X		
				1.6		0.06	24 V / DC / 7 W	100 % ED	–	–	0...13	0...12	385450	389753
							24 V / 50 Hz / 6 W		–	–	0...30	0...30	389757	389755
		230 V / 50 Hz / 6 W	–		–		0...30		0...30	389759	389761			
		24 V / DC / 5.5 W	0...9		0...9		–		–	389765	389762			
		24 V / DC / 5.5 W	–		–		0...10.5		0...10.5	X	X			
		24 V / 50 Hz / 4 W	0...24		0...24		0...24		0...24	389781	389783			
		230 V / 50 Hz / 4 W	0...24		0...24		0...24		0...24	389786	389785			
		24 V / DC / 14 W	50 % ED		–		–		0...25	0...25	X	X		
		24 V / DC / 11 W			0...20		0...20		–	–	X	X		
		24 V / DC / 11 W			–		–		0...22	0...22	X	X		
		2.0	0.11		24 V / DC / 7 W		100 % ED		–	–	0...9	0...9	385455	389787
					24 V / 50 Hz / 6 W				–	–	0...22	0...22	389791	389789
				230 V / 50 Hz / 6 W	–	–		0...22	0...22	389793	389794			
				24 V / DC / 5.5 W	0...6.5	0...6.5		–	–	389797	389795			
24 V / DC / 5.5 W	–			–	0...7	0...7		X	X					
24 V / 50 Hz / 4 W	0...18			0...18	0...18	0...18		389799	393079					
230 V / 50 Hz / 4 W	0...18			0...18	0...18	0...18		389801	389802					
24 V / DC / 14 W	50 % ED			–	–	0...19		0...19	X	X				
24 V / DC / 11 W				0...14	0...14	–		–	X	X				
24 V / DC / 11 W				–	–	0...16		0...16	X	X				

Circuit function	Port connection	Orifice	K _v value H ₂ O ¹⁾	Voltage/ Frequency/Power	Maximum duty cycle	Medium pressure [bar] ^{2) 3)}				Article no. Body material Brass	Article no. Body material stainless steel				
						Ambient temperature 75 °C		Ambient temperature 55 °C							
		[mm]	[m ³ /h]	[V/Hz/W]	Air	Water	Air	Water	FKM seal						
A, solenoid valve 2/2 way Direct-acting Normally closed 	M5	2.4	0.13	24 V / DC / 7 W	100 % ED	-	-	0...5	0...3.5	385457	389805				
				24 V / 50 Hz / 6 W		-	-	0...13	0...13	389807	389809				
				230 V / 50 Hz / 6 W		-	-	0...13	0...13	389811	389812				
				24 V / DC / 5.5 W		0...3.5	0...3	-	-	389813	389815				
				24 V / DC / 5.5 W		-	-	0...4	0...3.5	X	X				
				24 V / 50 Hz / 4 W		0...10	0...10	0...10	0...10	389817	389819				
				230 V / 50 Hz / 4 W		0...10	0...10	0...10	0...10	389821	389822				
				24 V / DC / 14 W		50 % ED	-	-	0...10	0...9	X	X			
				24 V / DC / 11 W		0...7	0...6.5	-	-	X	X				
				24 V / DC / 11 W		-	-	0...8	0...7.5	X	X				
				G 1/8		1.2	0.045	24 V / DC / 7 W	100 % ED	-	-	0...23	0...23	375821	375828
								24 V / 50 Hz / 6 W		-	-	0...45	0...45	389532	389540
								230 V / 50 Hz / 6 W		-	-	0...45	0...45	375968	375979
								24 V / DC / 5.5 W		0...16	0...16	-	-	375852	375860
								24 V / DC / 5.5 W		-	-	0...19	0...19	X	X
								24 V / 50 Hz / 4 W		0...42	0...42	0...42	0...42	389537	389544
								230 V / 50 Hz / 4 W		0...42	0...42	0...42	0...42	376005	376013
								24 V / DC / 14 W		50 % ED	-	-	0...45	0...45	X
	24 V / DC / 11 W	0...35	0...35		-			-		X	X				
	24 V / DC / 11 W	-	-		0...37			0...37		X	X				
	1.6	0.06	24 V / DC / 7 W		100 % ED			-		-	0...13	0...12	374309	375829	
			24 V / 50 Hz / 6 W					-		-	0...30	0...30	389657	389658	
			230 V / 50 Hz / 6 W					-		-	0...30	0...30	375969	375980	
			24 V / DC / 5.5 W					0...9		0...9	-	-	375853	375861	
			24 V / DC / 5.5 W					-		-	0...10.5	0...10.5	X	X	
			24 V / 50 Hz / 4 W					0...24		0...24	0...24	0...24	389661	389662	
			230 V / 50 Hz / 4 W					0...24		0...24	0...24	0...24	376006	376015	
			24 V / DC / 14 W					50 % ED		-	-	0...25	0...25	X	X
			24 V / DC / 11 W	0...20		0...20	-	-	X	X					
			24 V / DC / 11 W	-		-	0...22	0...22	X	X					
			2.0	0.11		24 V / DC / 7 W	100 % ED	-	-	0...9	0...9	375822	375830		
						24 V / 50 Hz / 6 W		-	-	0...22	0...22	389677	389680		
						230 V / 50 Hz / 6 W		-	-	0...22	0...22	375970	375981		
						24 V / DC / 5.5 W		0...6.5	0...6.5	-	-	375854	375862		
						24 V / DC / 5.5 W		-	-	0...7	0...7	X	X		
						24 V / 50 Hz / 4 W		0...18	0...18	0...18	0...18	389672	389669		
						230 V / 50 Hz / 4 W		0...18	0...18	0...18	0...18	376007	376016		
						24 V / DC / 14 W		50 % ED	-	-	0...19	0...19	X	X	
	24 V / DC / 11 W	0...14			0...14	-		-	X	X					
	24 V / DC / 11 W	-			-	0...16		0...16	X	X					
	2.4	0.13			24 V / DC / 7 W	100 % ED		-	-	0...5	0...3.5	375823	375831		
					24 V / 50 Hz / 6 W			-	-	0...13	0...13	393638	393689		
					230 V / 50 Hz / 6 W			-	-	0...13	0...13	375971	375982		
					24 V / DC / 5.5 W			0...3.5	0...3	-	-	375855	375863		
					24 V / DC / 5.5 W			-	-	0...4	0...3.5	X	X		
					24 V / 50 Hz / 4 W			0...10	0...10	0...10	0...10	389696	389697		
					230 V / 50 Hz / 4 W			0...10	0...10	0...10	0...10	376008	376017		
					24 V / DC / 14 W			50 % ED	-	-	0...10	0...9	X	X	
24 V / DC / 11 W			0...7	0...6.5	-		-	X	X						
24 V / DC / 11 W			-	-	0...8		0...7.5	X	X						

DTS 1000446515 EN Version: F Status: RL (released | freigegeben | valide) printed: 17.03.2022

Circuit function	Port connection	Orifice	K _v value H ₂ O ¹⁾	Voltage/ Frequency/Power	Maximum duty cycle	Medium pressure [bar] ^{2) 3)}				Article no. Body material Brass	Article no. Body material stainless steel			
						Ambient temperature 75 °C		Ambient temperature 55 °C						
		[mm]	[m ³ /h]	[V/Hz/W]	Air	Water	Air	Water	FKM seal					
A, solenoid valve 2/2 way Direct-acting Normally closed 	Flange (FK01)	1.2	0.045	24 V / DC / 7 W	100 % ED	-	-	0...23	0...23	375836	375844			
				24 V / 50 Hz / 6 W		-	-	0...45	0...45	389699	389700			
				230 V / 50 Hz / 6 W		-	-	0...45	0...45	375987	375996			
				24 V / DC / 5.5 W		0...16	0...16	-	-	375868	375876			
				24 V / DC / 5.5 W		-	-	0...19	0...19	X	X			
				24 V / 50 Hz / 4 W		0...42	0...42	0...42	0...42	389704	389703			
				230 V / 50 Hz / 4 W		0...42	0...42	0...42	0...42	376023	376031			
				24 V / DC / 14 W		50 % ED	-	-	0...45	0...45	X	X		
				24 V / DC / 11 W			0...35	0...35	-	-	X	X		
				24 V / DC / 11 W			-	-	0...37	0...37	X	X		
				1.6		0.06	100 % ED	24 V / DC / 7 W	-	-	0...13	0...12	375837	375845
								24 V / 50 Hz / 6 W	-	-	0...30	0...30	389705	389706
		230 V / 50 Hz / 6 W	-		-			0...30	0...30	375988	375997			
		24 V / DC / 5.5 W	0...9		0...9			-	-	375869	375877			
		24 V / DC / 5.5 W	-		-			0...10.5	0...10.5	X	X			
		24 V / 50 Hz / 4 W	0...24		0...24			0...24	0...24	389708	389709			
		230 V / 50 Hz / 4 W	0...24		0...24			0...24	0...24	376024	376032			
		24 V / DC / 14 W	50 % ED		-			-	0...25	0...25	X	X		
		24 V / DC / 11 W			0...20			0...20	-	-	X	X		
		24 V / DC / 11 W			-			-	0...22	0...22	X	X		
		2.0	0.11		100 % ED			24 V / DC / 7 W	-	-	0...9	0...9	375838	375846
								24 V / 50 Hz / 6 W	-	-	0...22	0...22	389711	389712
				230 V / 50 Hz / 6 W		-	-	0...22	0...22	375989	375999			
				24 V / DC / 5.5 W		0...6.5	0...6.5	-	-	375870	375878			
				24 V / DC / 5.5 W		-	-	0...7	0...7	X	X			
				24 V / 50 Hz / 4 W		0...18	0...18	0...18	0...18	389714	389715			
				230 V / 50 Hz / 4 W		0...18	0...18	0...18	0...18	376025	376033			
				24 V / DC / 14 W		50 % ED	-	-	0...19	0...19	X	X		
				24 V / DC / 11 W			0...14	0...14	-	-	X	X		
				24 V / DC / 11 W			-	-	0...16	0...16	X	X		
				2.4		0.13	100 % ED	24 V / DC / 7 W	-	-	0...5	0...3.5	375839	375847
								24 V / 50 Hz / 6 W	-	-	0...13	0...13	389716	389717
		230 V / 50 Hz / 6 W	-		-			0...13	0...13	375990	376000			
		24 V / DC / 5.5 W	0...3.5		0...3			-	-	375871	375879			
		24 V / DC / 5.5 W	-		-			0...4	0...3.5	X	X			
		24 V / 50 Hz / 4 W	0...10		0...10			0...10	0...10	389719	389718			
		230 V / 50 Hz / 4 W	0...10		0...10			0...10	0...10	376026	376034			
		24 V / DC / 14 W	50 % ED		-			-	0...10	0...9	X	X		
		24 V / DC / 11 W			0...7			0...6.5	-	-	X	X		
		24 V / DC / 11 W			-			-	0...8	0...7.5	X	X		

DTS 1000446515 EN Version: F Status: RL (released | freigegeben | valide) printed: 17.03.2022

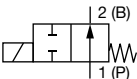
Circuit function	Port connection	Orifice	K _v value H ₂ O ^{1.)}	Voltage/ Frequency/Power	Maximum duty cycle	Medium pressure [bar] ^{2.) 3.)}				Article no. Body material Brass	Article no. Body material stainless steel	
						Ambient temperature 75 °C		Ambient temperature 55 °C				
		[mm]	[m ³ /h]	[V/Hz/W]		Air	Water	Air	Water	FKM seal		
B, solenoid valve 2/2 way Direct-acting Normally open 	G 1/8	2.0	0.10	24 V / DC / 7 W	100 % ED	–	–	0...12	–	20007424	X	
				24 V / 50 Hz / 6 W		–	–	0...14.5	–	X	X	
				230 V / 50 Hz / 6 W		–	–	0...14.5	–	20007106	X	
				24 V / DC / 5.5 W		0...10	–	–	–	20007425	X	
				24 V / 50 Hz / 4 W		0...13	–	–	–	X	X	
	230 V / 50 Hz / 4 W	0...13	–	–	–	20007423	X					
	Flange (FK01)	2.0	0.10	0.10	24 V / DC / 7 W	100 % ED	–	–	0...12	–	20009528	X
					24 V / 50 Hz / 6 W		–	–	0...14.5	–	X	X
					230 V / 50 Hz / 6 W		–	–	0...14.5	–	20009536	X
					24 V / DC / 5.5 W		0...10	–	–	–	20009530	X
24 V / 50 Hz / 4 W					0...13		–	–	–	X	X	
230 V / 50 Hz / 4 W	0...13	–	–	–	20009532	X						

X: on request

1.) Flow value for water, measured at +20 °C, 1 bar^{2.)} pressure at valve inlet and free outlet

2.) Measured as overpressure to the atmospheric pressure and air as a medium

3.) Number of switching cycles under laboratory conditions (FKM seal, oiled air, unpressurised, WWA, DC): 5 million (with WWB less numbers of switching cycles). Please note that an increase in switching pressure can limit the life of the seat seal.

DVGW version**Note:**

- With NBR seal and brass body (class B)
- According to gas appliance directive: valve class A, valve group 2

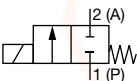
Circuit function	Port connection	Orifice	K _v value H ₂ O ^{1.)}	Voltage/ Frequency/Power	Maximum duty cycle	Medium pressure [bar] ^{2.) 3.)}				Article no. Body material Brass	Article no. Body material stainless steel
						Ambient temperature 55 °C					
		[mm]	[m ³ /h]	[V/Hz/W]		Air	Water	Air	Water	FKM seal	
A, solenoid valve 2/2 way Direct-acting Normally closed 	G 1/8	1.2	0.04	24 V / DC / 7 W	100 % ED	0...23	–	20010449	X		
				24 V / DC / 5.5 W		0...19	–	20010443	X		
				0.045		24 V / 50 Hz / 4 W	0...42	–	X		
		1.6	0.055	230 V / 50 Hz / 4 W	100 % ED	0...42	–	20010456	X		
				24 V / DC / 7 W		0...13	–	20010450	X		
				24 V / DC / 5.5 W		0...10.5	–	20009374	X		
		0.06	24 V / 50 Hz / 4 W	230 V / 50 Hz / 4 W	100 % ED	0...24	–	–	X		
						0...24	–	20010460	X		
						0...9	–	20010451	X		
		2.0	0.07	24 V / DC / 7 W	100 % ED	0...7	–	20010446	X		
						24 V / DC / 5.5 W	0...18	–	X		
						0.11	24 V / 50 Hz / 4 W	0...18	–	X	
		2.4	0.09	24 V / 50 Hz / 6 W	100 % ED	230 V / 50 Hz / 4 W	0...18	–	20010461	X	
						24 V / DC / 7 W	0...5	–	20010454	X	
						24 V / DC / 5.5 W	0...4	–	20010447	X	
0.13	24 V / 50 Hz / 6 W					0...10	–	X			
230 V / 50 Hz / 6 W	0...10	–	20010464	X							

X: on request

1.) Flow value for water, measured at +20 °C, 1 bar^{2.)} pressure at valve inlet and free outlet

2.) Measured as overpressure to the atmospheric pressure and air as a medium

ATEX/IECEx version

Note:

- The maximum media temperature must not exceed the permissible temperature class (T4 135 °C) minus 5 K in any case.
- Only single mounting permissible
- With 3 m cable as standard. Other lengths on request.

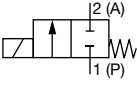
Circuit function	Port connection	Orifice	K _v value H ₂ O ^{1.)}	Voltage/ Frequency/Power	Maximum duty cycle	Medium pressure [bar] ^{2.) 3.)}		Article no. Body material Brass	Article no. Body material stainless steel
		[mm]	[m ³ /h]	[V/Hz/W]		Air	Water		
						FKM seal			
A, solenoid valve 2/2 way Direct-acting Normally closed 	G1/8	1.2	0.045	24 V / AC/DC / 6 W	100 % ED	0...16	0...16	20009727	X
				24 V / 50 Hz / 6 W		0...34	0...34	20012934	X
				230 V / 50 Hz / 6 W		0...34	0...34	20014398	X
		1.6	0.06	24 V / AC/DC / 6 W	100 % ED	0...10	0...10	20009728	X
				24 V / 50 Hz / 6 W		0...18	0...18	20012935	X
				230 V / 50 Hz / 6 W		0...18	0...18	20014408	X
		2.0	0.11	24 V / AC/DC / 6 W	100 % ED	0...7	0...7	20009725	X
				24 V / 50 Hz / 6 W		0...13	0...13	20012931	X
				230 V / 50 Hz / 6 W		0...13	0...13	20025748	X
		2.4	0.13	24 V / AC/DC / 6 W	100 % ED	0...4	0...3.5	20009729	X
				24 V / 50 Hz / 6 W		0...7	0...6.5	20012938	X
				230 V / 50 Hz / 6 W		0...7	0...6.5	20014416	X

X: on request

1.) Flow value for water, measured at +20 °C, 1 bar^{2.)} pressure at valve inlet and free outlet

2.) Measured as overpressure to the atmospheric pressure and air as a medium

Standard version according to industry standard Form B, coil size 20 mm

Note:

All valves without cable plug

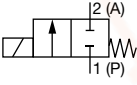
Circuit function	Port connection	Orifice	K _v value H ₂ O ^{1.)}	Voltage/ Frequency/Power	Maximum duty cycle	Medium pressure [bar] ^{2.) 3.)}		Article no. Body material Brass	Article no. Body material stainless steel
		[mm]	[m ³ /h]	[V/Hz/W]		Ambient temperature 75 °C	Ambient temperature 55 °C		
						Air	Air		
A, solenoid valve 2/2 way Direct-acting Normally closed 	M5	1.2	0.045	24 V / DC / 6.5 W	100 % ED	–	0...13	X	X
				24 V / 50 Hz / 6 W		–	0...35	X	X
				230 V / 50 Hz / 6 W		–	0...35	X	X
				24 V / DC / 5 W		0...9	–	X	X
				24 V / DC / 5 W		–	0...11	X	X
				24 V / 50 Hz / 4 W		0...27	0...27	X	X
				230 V / 50 Hz / 4 W		0...27	0...27	X	X
				24 V / DC / 14 W		–	0...32	X	X
				24 V / DC / 11 W		0...25	–	X	X
		24 V / DC / 11 W	–	0...30	X	X			
		1.6	0.06	24 V / DC / 6.5 W	100 % ED	–	0...8.5	X	X
				24 V / 50 Hz / 6 W		–	0...24	X	X
				230 V / 50 Hz / 6 W		–	0...24	X	X
				24 V / DC / 5 W		0...5.5	–	X	X
				24 V / DC / 5 W		–	0...6.5	X	X
				24 V / 50 Hz / 4 W		0...17	0...17	X	X
				230 V / 50 Hz / 4 W		0...17	0...17	X	X
				24 V / DC / 14 W		–	0...22	X	X
24 V / DC / 11 W	0...17			–		X	X		
24 V / DC / 11 W	–	0...18	X	X					

Circuit function	Port connection	Orifice	K _v value H ₂ O ¹⁾	Voltage/ Frequency/Power	Maximum duty cycle	Medium pressure [bar] ^{2) 3)}		Article no. Body material Brass	Article no. Body material stainless steel		
						Ambient temperature 75 °C	Ambient temperature 55 °C				
		[mm]	[m ³ /h]	[V/Hz/W]		Air	Air	FKM seal			
A, solenoid valve 2/2 way Direct-acting Normally closed 	M5	2.0	0.11	24 V / DC / 6.5 W	100 % ED	-	0...6	X	X		
				24 V / 50 Hz / 6 W		-	0...14	X	X		
				230 V / 50 Hz / 6 W		-	0...14	X	X		
				24 V / DC / 5 W		0...4	-	X	X		
				24 V / DC / 5 W		-	0...4.5	X	X		
				24 V / 50 Hz / 4 W		0...10	0...10	X	X		
				230 V / 50 Hz / 4 W		0...10	0...10	X	X		
				24 V / DC / 14 W		50 % ED	-	0...15	X	X	
				24 V / DC / 11 W			0...12	-	X	X	
				24 V / DC / 11 W			-	0...13	X	X	
				24 V / DC / 6.5 W			100 % ED	-	0...3	X	X
				24 V / 50 Hz / 6 W				-	0...9	X	X
		230 V / 50 Hz / 6 W	-	0...9	X			X			
		24 V / DC / 5 W	0...2	-	X	X					
		24 V / DC / 5 W	-	0...2.5	X	X					
		24 V / 50 Hz / 4 W	0...6.5	0...6.5	X	X					
		230 V / 50 Hz / 4 W	0...6.5	0...6.5	X	X					
		24 V / DC / 14 W	50 % ED	-	0...8	X	X				
		24 V / DC / 11 W		0...6	-	X	X				
		24 V / DC / 11 W		-	0...6.5	X	X				
		G 1/8	1.2	0.045	24 V / DC / 6.5 W	100 % ED	-	0...13	X	X	
					24 V / 50 Hz / 6 W		-	0...35	X	X	
					230 V / 50 Hz / 6 W		-	0...35	X	X	
					24 V / DC / 5 W		0...9	-	X	X	
	24 V / DC / 5 W				-		0...11	X	X		
	24 V / 50 Hz / 4 W				0...27		0...27	X	X		
	230 V / 50 Hz / 4 W				0...27		0...27	X	X		
	24 V / DC / 14 W				50 % ED		-	0...32	X	X	
	24 V / DC / 11 W						0...25	-	X	X	
	24 V / DC / 11 W						-	0...30	X	X	
	24 V / DC / 6.5 W						100 % ED	-	0...8.5	X	X
	24 V / 50 Hz / 6 W							-	0...24	X	X
	230 V / 50 Hz / 6 W		-	0...24		X		X			
	24 V / DC / 5 W		0...5.5	-	X	X					
	24 V / DC / 5 W		-	0...6.5	X	X					
	24 V / 50 Hz / 4 W		0...17	0...17	X	X					
	230 V / 50 Hz / 4 W		0...17	0...17	X	X					
	24 V / DC / 14 W		50 % ED	-	0...22	X		X			
	24 V / DC / 11 W			0...17	-	X		X			
	24 V / DC / 11 W			-	0...18	X		X			
	24 V / DC / 6.5 W			100 % ED	-	0...6		X	X		
	24 V / 50 Hz / 6 W				-	0...14		X	X		
	230 V / 50 Hz / 6 W				-	0...14	X	X			
	24 V / DC / 5 W		0...4		-	X	X				
	24 V / DC / 5 W	-	0...4.5		X	X					
	24 V / 50 Hz / 4 W	0...10	0...10		X	X					
	230 V / 50 Hz / 4 W	0...10	0...10		X	X					
	24 V / DC / 14 W	50 % ED	-		0...15	X	X				
24 V / DC / 11 W	0...12		-		X	X					
24 V / DC / 11 W	-		0...13		X	X					

DTS 1000446515 EN Version: F Status: RL (released | freigegeben | valide) printed: 17.03.2022

Circuit function	Port connection	Orifice		Voltage/ Frequency/Power	Maximum duty cycle	Medium pressure [bar] ^{2) 3)}		Article no. Body material Brass	Article no. Body material stainless steel		
		[mm]	[m ³ /h]			Ambient temperature 75 °C	Ambient temperature 55 °C				
		[mm]	[m ³ /h]			Air	Air			FKM seal	
A, solenoid valve 2/2 way Direct-acting Normally closed 	G 1/8	2.4	0.13	24 V / DC / 6.5 W	100 % ED	-	0...3	X	X		
				24 V / 50 Hz / 6 W		-	0...9	X	X		
				230 V / 50 Hz / 6 W		-	0...9	X	X		
				24 V / DC / 5 W		0...2	-	X	X		
				24 V / DC / 5 W		-	0...2.5	X	X		
				24 V / 50 Hz / 4 W		0...6.5	0...6.5	X	X		
		230 V / 50 Hz / 4 W	0...6.5	0...6.5	X	X					
		24 V / DC / 14 W	50 % ED	-	0...8	X	X				
		24 V / DC / 11 W		0...6	-	X	X				
		24 V / DC / 11 W		-	0...6.5	X	X				
		Flange (FK01)	1.2	0.045	0.045	24 V / DC / 6.5 W	100 % ED	-	0...13	X	X
						24 V / 50 Hz / 6 W		-	0...35	X	X
	230 V / 50 Hz / 6 W					-		0...35	X	X	
	24 V / DC / 5 W					0...9		-	X	X	
	24 V / DC / 5 W					-		0...11	X	X	
	24 V / 50 Hz / 4 W					0...27		0...27	X	X	
	230 V / 50 Hz / 4 W		0...27	0...27	X	X					
	24 V / DC / 14 W		50 % ED	-	0...32	X	X				
	24 V / DC / 11 W			0...25	-	X	X				
	24 V / DC / 11 W			-	0...30	X	X				
	Flange (FK01)		1.6	0.06	0.06	24 V / DC / 6.5 W	100 % ED	-	0...8.5	X	X
						24 V / 50 Hz / 6 W		-	0...24	X	X
		230 V / 50 Hz / 6 W				-		0...24	X	X	
		24 V / DC / 5 W				0...5.5		-	X	X	
24 V / DC / 5 W		-				0...6.5		X	X		
24 V / 50 Hz / 4 W		0...17				0...17		X	X		
230 V / 50 Hz / 4 W		0...17	0...17	X	X						
24 V / DC / 14 W		50 % ED	-	0...22	X	X					
24 V / DC / 11 W			0...17	-	X	X					
24 V / DC / 11 W			-	0...18	X	X					
Flange (FK01)		2.0	0.11	0.11	24 V / DC / 6.5 W	100 % ED	-	0...6	X	X	
					24 V / 50 Hz / 6 W		-	0...14	X	X	
	230 V / 50 Hz / 6 W				-		0...14	X	X		
	24 V / DC / 5 W				0...4		-	X	X		
	24 V / DC / 5 W				-		0...4.5	X	X		
	24 V / 50 Hz / 4 W				0...10		0...10	X	X		
	230 V / 50 Hz / 4 W	0...10	0...10	X	X						
	24 V / DC / 14 W	50 % ED	-	0...15	X	X					
	24 V / DC / 11 W		0...12	-	X	X					
	24 V / DC / 11 W		-	0...13	X	X					
	Flange (FK01)	2.4	0.13	0.13	24 V / DC / 6.5 W	100 % ED	-	0...3	X	X	
					24 V / 50 Hz / 6 W		-	0...9	X	X	
230 V / 50 Hz / 6 W					-		0...9	X	X		
24 V / DC / 5 W					0...2		-	X	X		
24 V / DC / 5 W					-		0...2.5	X	X		
24 V / 50 Hz / 4 W					0...6.5		0...6.5	X	X		
230 V / 50 Hz / 4 W		0...6.5	0...6.5	X	X						
24 V / DC / 14 W		50 % ED	-	0...8	X	X					
24 V / DC / 11 W			0...6	-	X	X					
24 V / DC / 11 W			-	0...6.5	X	X					

X: on request

- 1.) Flow value for water, measured at +20 °C, 1 bar²⁾ pressure at valve inlet and free outlet
- 2.) Measured as overpressure to the atmospheric pressure and air as a medium
- 3.) Number of switching cycles under laboratory conditions (FKM seal, oiled air, unpressurised, WWA, DC): 5 million. Please note that an increase in switching pressure can limit the life of the seat seal.

Additional options



Note:

Available on request

Option	Variable Code	Description
Oxygen versions	NL02	Suitable for applications with oxygen (non-metal materials that are in contact with the medium are tested and approved according to BAM)
Increased purity requirements e.g. oil, grease and silicone-free	NL50/NL05	Wetted parts are specially cleaned and packaged in accordance with the valves
Increased tightness requirements	PC05	Leakage rate *less than 10^{-4} mbar l/sec
	PC08	Leakage rate *less than 10^{-5} mbar l/sec
	PC06	Leakage rate *less than 10^{-6} mbar l/sec

8.4. Ordering chart accessories





Accessories for manifolds

Accessory	Features	Article no.
Screw plug	With sealing ring, G 1/8	005041 
Cover plate	For unoccupied valve position	005100 

Cable plug Type 2516 acc. to DIN EN 175301 -803 Form C

Note:





- Delivery of cable plug includes a flat seal and a fixing screw.
- Further versions of cable plug with circuitry acc. to DIN EN 175 301 -803 Form C as well as detailed technical data, see data sheet **Type 2516** .

Cable plug	Version	Voltage	Article no.
	Without circuitry (standard)	0...250 V AC/DC	303141 
	With LED	12...24 V AC/DC	303145 
	With LED and varistor	12...24 V AC/DC	303148 
	With rectifier, LED and varistor	12...24 V AC/DC	303142 

Cable plug Type 2507 acc. to industry standard Form B

Note:

- Delivery of cable plug includes a flat seal and a fixing screw.
- Further versions of cable plug with circuitry acc. to industry standard connector Form B as well as detailed technical data, see data sheet **Type 2507** .

Cable plug	Version	Voltage	Article no.
	Without circuitry (standard)	2...250 V AC/DC	423845 
	With LED	24 V AC/DC	423849 
	With LED and free-wheeling diode	12...24 V AC/DC	423851 
	With rectifier, LED and varistor	12...24 V AC/DC	423853 

Visit product website 