

## Series 55 Tecno-FUN

### General

This line of different logic functions that can be used in any place of the secondary pneumatic circuit, developed to be installed directly onto the main pneumatic components (distributors or cylinders).

Thanks to the modular design it is possible to easily join together multiple logic functions without the need of using pipes to connect them; it is also possible to choose the type and style of each connection. The connections available are the following: straight cartridge; Banjo PL cartridge; male cartridge threaded 1/8" or 1/4" and female cartridge threaded 1/8".

Function fittings can also be assembled side by side in order to be assembled on the DIN EN 50022 rail (using the relevant kit).



### Other characteristics:

Technopolymer body

Input/output connection directly integrated into the body

In line or 90° connection

Possibility to build a manifold -parallel mounting-

Different connection options:

Tube Ø4 Ø6 Ø8 (elbow version as well)

G1/8" G1/4" male straight cartridge

G1/8" female cartridge, in line or 90°

### Different mounting options:

- Wall fixing through the holes in the body
- By means of the fixing bracket
- Panel mounting (for those function that include such possibility)
- On DIN rail EN 50022 (using the DIN rail adapter kit)

### Available functions

- Flow control valve
- Pressure regulator
- Block valve
- Quick exhaust valve
- OR gate
- AND gate
- Pressure gauge
- Progressive start-up valve
- Pressure regulator + pressure gauge
- Block valve + Flow control valve
- Block valve + quick exhaust valve



**Flow regulator**

Coding: 551.11T.A.B.XX

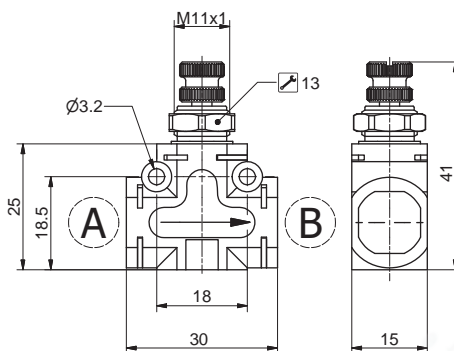

TYPE	
<b>T</b>	1 = Unidirectional 2 = Bidirectional
CONNECTION A	SEE CONNECTIONS LIST
CONNECTION B	SEE CONNECTIONS LIST
CONNECTIONS LIST	
00	= None
D4	= Straight Ø4
D6	= Straight Ø6
D8	= Straight Ø8
L1	= Female banjo G1/8"
G4	= Rotating banjo Ø4
G6	= Rotating banjo Ø6
G8	= Rotating banjo Ø8
M1	= G1/8" male
M2	= G1/4" male
F1	= G1/8" female

Example: 551.111.D6.D6.XX  
Flow control valve unidirectional, CONNECTIONS "A" and "B" Tube Ø6  
NOTE : For the dimension including cartridges see page Accessories - Function fittings

**Piloting curves**

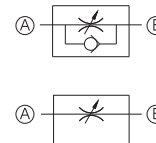
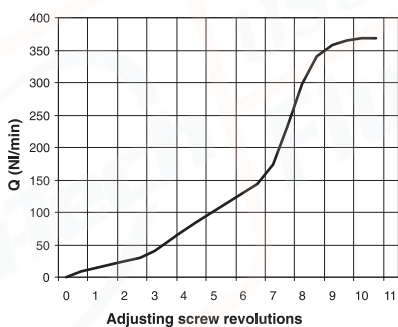

**Construction characteristics**

- The flow control valve is normally used to regulate the air flow and, as a consequence, for example, the speed of a cylinder. Two types of flow control valves are available: unidirectional and bidirectional. In the unidirectional valve the flow is regulated only in one direction while it is free to move in the opposite direction; in the bidirectional valve the flow is regulated in both directions.
- Panel mounting using the lock nut supplied as standard
- on DIN rail using the relevant adaptor kit (see accessories)
- With 90° bracket (see accessories)
- directly on the support plate thanks to two through holes on the body

**Technical characteristics**

Fluid	Filtered air. No lubrication needed, if applied it shall be continuous
Working ports size	See CONNECTIONS LIST
Max working pressure (bar)	10
Orifice size (mm)	Ø3
Free exhaust flow rate in the opposite side of the regulation	800 (for unidirectional version)
Temperature °C	-5 ÷ +50
Weight (g)	26

1  
AIR DISTRIBUTION

**In line pressure regulator**

Coding: 551.12**T.A.B.**XX

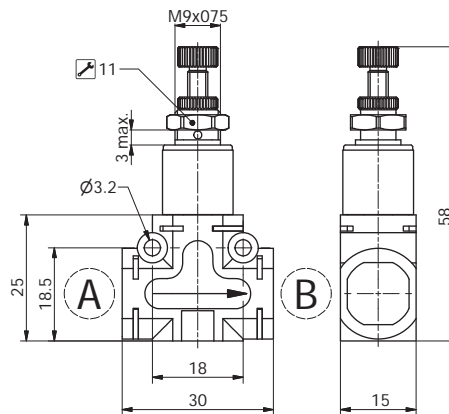

TYPE	
<b>T</b>	2 = 0-2 bar
	4 = 0-4 bar
	8 = 0-8 bar
CONNECTION A	
<b>A</b>	SEE CONNECTIONS LIST
CONNECTION B	
<b>B</b>	SEE CONNECTIONS LIST
CONNECTIONS LIST	
<b>00</b>	= None
<b>D4</b>	= Straight Ø4
<b>D6</b>	= Straight Ø6
<b>D8</b>	= Straight Ø8
<b>L1</b>	= Female banjo G1/8"
<b>G4</b>	= Rotating banjo Ø 4
<b>G6</b>	= Rotating banjo Ø 6
<b>G8</b>	= Rotating banjo Ø 8
<b>M1</b>	= G1/8" male
<b>M2</b>	= G1/4" male
<b>F1</b>	= G1/8" female

Example: 551.128.D8.D8.XX

In line pressure regulator, pressure range (bar) 0-8 bar. Connections "A" and "B" Tube Ø6  
NOTE : For the dimension including cartridges see page Accessories - Function fittings

**Construction characteristics**

- The pressure regulator is a device which is used to reduce, regulate and stabilize the air pressure in a conduit in order to adapt it to the needs of the equipments to be supplied. The pressure regulator incorporates the relieving function.
- Panel mounting using the lock nut supplied as standard
- on DIN rail using the relevant adaptor kit (see accessories)
- With 90° bracket (see accessories)
- directly on the support plate thanks to two through holes on the body

Technical characteristics	
Fluid	Filtered air. No lubrication needed, if applied it shall be continuous
Working ports size	See CONNECTIONS LIST
Max working pressure (bar)	10
Flow rate at 6 bar with Δp=1 (NI/min)	180
Pressure range (bar)	0÷2 / 0÷4 / 0÷8
Temperature °C	-5 ÷ +50
Weight (g)	31

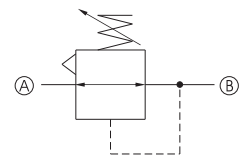

**90° pressure regulator**

Coding: 551.22**T.A.B.**XX

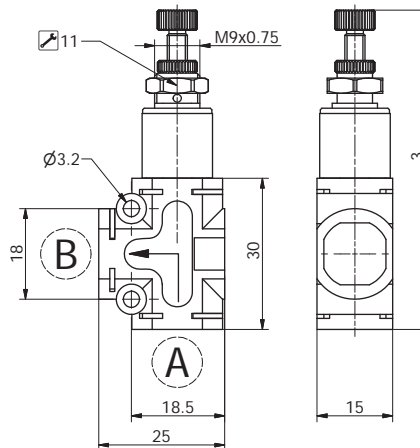

TYPE	
<b>T</b>	2 = 0-2 bar
	4 = 0-4 bar
	8 = 0-8 bar
CONNECTION A	
<b>A</b>	SEE CONNECTIONS LIST
CONNECTION B	
<b>B</b>	SEE CONNECTIONS LIST
CONNECTIONS LIST	
<b>00</b>	= None
<b>D4</b>	= Straight Ø4
<b>D6</b>	= Straight Ø6
<b>D8</b>	= Straight Ø8
<b>L1</b>	= Female banjo G1/8"
<b>G4</b>	= Rotating banjo Ø 4
<b>G6</b>	= Rotating banjo Ø 6
<b>G8</b>	= Rotating banjo Ø 8
<b>M1</b>	= G1/8" male
<b>M2</b>	= G1/4" male
<b>F1</b>	= G1/8" female

Example: 551.224.M1.D6.XX

90° pressure regulator, pressure range (bar) 0 - 4 bar. Connections "A" Male G1/8 and "B" Tube Ø6  
NOTE : For the dimension including cartridges see page Accessories - Function fittings

**Construction characteristics**

- The pressure regulator is a device which is used to reduce, regulate and stabilize the air pressure in a conduit in order to adapt it to the needs of the equipments to be supplied. The pressure regulator incorporates the relieving function.
- Panel mounting using the lock nut supplied as standard
- on DIN rail using the relevant adaptor kit (see accessories)
- With 90° bracket (see accessories)
- directly on the support plate thanks to two through holes on the body

Technical characteristics	
Fluid	Filtered air. No lubrication needed, if applied it shall be continuous
Working ports size	See CONNECTIONS LIST
Max working pressure (bar)	10
Flow rate at 6 bar with Δp=1 (NI/min)	180
Pressure range (bar)	0÷2 / 0÷4 / 0÷8
Temperature °C	-5 ÷ +50
Weight (g)	31

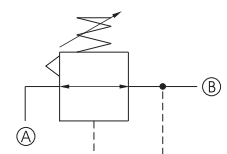

Blocking valve

Coding: 551.13T.A.B.XX

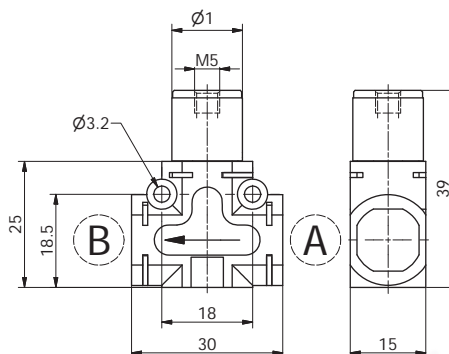

TYPE	
<b>T</b>	1 = Unidirectional 2 = Bidirectional
CONNECTION A	SEE CONNECTIONS LIST
CONNECTION B	SEE CONNECTIONS LIST
CONNECTIONS LIST	
00	= None
D4	= Straight Ø4
D6	= Straight Ø6
D8	= Straight Ø8
L1	= Female banjo G1/8"
G4	= Rotating banjo Ø4
G6	= Rotating banjo Ø6
G8	= Rotating banjo Ø8
M1	= G1/8" male
M2	= G1/4" male
F1	= G1/8" female

Example: 551.131.D4.D4.XX  
In line blocking valve, unidirectional. Connections "A" and "B" Tube Ø4  
NOTE : For the dimension including cartridges see page Accessories - Function fittings

Piloting curves

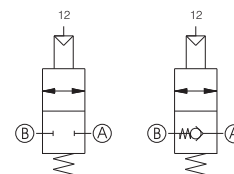
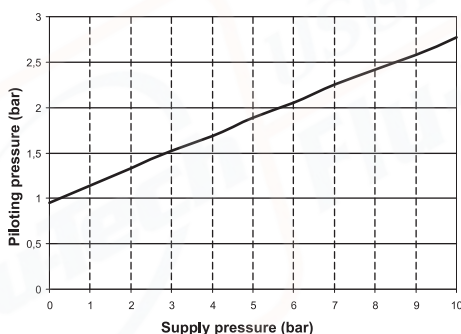

Construction characteristics

- The blocking valve function is to maintain the circuit downstream pressure in the event of loss of supply pressure. It is normally fitted directly onto the cylinder connections ports in order to ensure that, in case of accidental loss of the supply pressure, the units positions is maintained. This is achieved as the blocking valve preserves the pressure inside the pressurised chamber. Blocking valves can be unidirectional or bidirectional.
- In the unidirectional version the air flow is free in one direction while in order to allow the flow in the opposite direction is necessary to send a pneumatic signal to the unit connection 12.
- The bidirectional version requires a pneumatic signal on connection 12 to allow the flow in any of the two directions.
- on DIN rail using the relevant adaptor kit (see accessories)
- With 90° bracket (see accessories)
- directly on the support plate thanks to two through holes on the body

Technical characteristics

Fluid	Filtered air. No lubrication needed, if applied it shall be continuous
Working ports size	SEE CONNECTIONS LIST
Max working pressure (bar)	0,5 ÷ 10
Flow rate at 6 bar with Δp=1 (Nl/min)	285
Flow rate at 6 bar with free exhaust (Nl/min)	450
Temperature °C	-5 ÷ +50
Weight (g)	26

1 AIR DISTRIBUTION

90° blocking valve

Coding: 551.231.T.A.B.XX

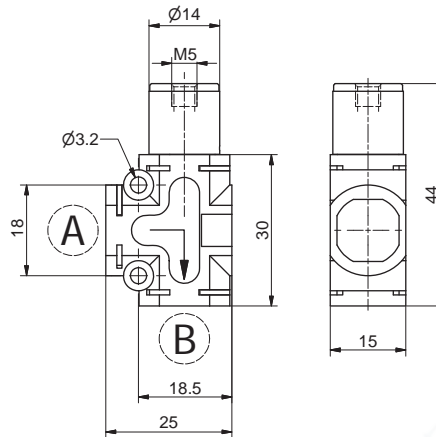

TYPE	
T	1 = Unidirectional 2 = Bidirectional
CONNECTION A	
A	SEE CONNECTIONS LIST
CONNECTION B	
B	SEE CONNECTIONS LIST
CONNECTIONS LIST	
00	None
D4	Straight Ø4
D6	Straight Ø6
D8	Straight Ø8
L1	Female banjo G1/8"
G4	Rotating banjo Ø 4
G6	Rotating banjo Ø 6
G8	Rotating banjo Ø 8
M1	G1/8" male
M2	G1/4" male
F1	G1/8" female

1 AIR DISTRIBUTION

Example: 551.231.D6.M1.XX

90° blocking valve. Connections "A" Male G1/8 and "B" Tube Ø6

NOTE : For the dimension including cartridges see page Accessories - Function fittings

Piloting curves

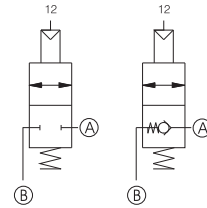
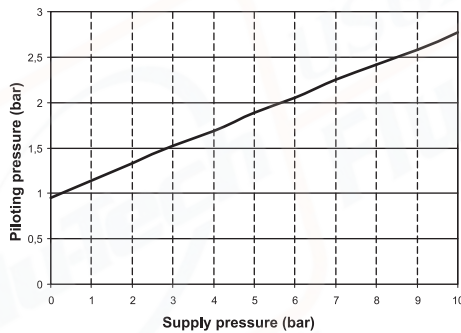

Construction characteristics

- The blocking valve function is to maintain the circuit downstream pressure in the event of loss of supply pressure. It is normally fitted directly onto the cylinder connections ports in order to ensure that, in case of accidental loss of the supply pressure, the units positions is maintained. This is achieved as the blocking valve preserves the pressure inside the pressurised chamber.
- Unidirectional and bidirectional version are both available.
- In the unidirectional version the air flow is free in one direction while in order to allow the flow in the opposite direction is necessary to send a pneumatic signal to the unit connection 12.
- The bidirectional version requires a pneumatic signal on connection 12 to allow the flow in any of the two directions.
- on DIN rail using the relevant adaptor kit (see accessories)
- With 90° bracket (see accessories)
- directly on the support plate thanks to two through holes on the body

Technical characteristics

Fluid	Filtered air. No lubrication needed, if applied it shall be continuous
Working ports size	See CONNECTIONS LIST
Max working pressure (bar)	0,5 ÷ 10
Flow rate at 6 bar with Δp=1 (NI/min)	285
Flow rate at 6 bar with free exhaust (NI/min)	450
Temperature °C	-5 ÷ +50
Weight (g)	26

**Circuit selector valve - OR**

Coding: 551.141.A.B.C

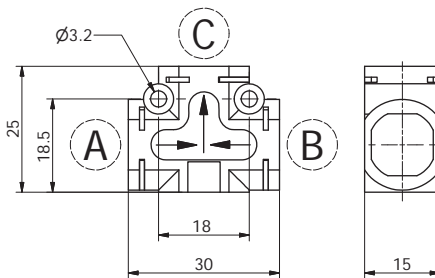

<b>A</b>	CONNECTION A <b>SEE CONNECTIONS LIST</b>
<b>B</b>	CONNECTION B <b>SEE CONNECTIONS LIST</b>
<b>C</b>	CONNECTION C <b>SEE CONNECTIONS LIST</b>
<b>CONNECTIONS LIST</b>	
00 = None	
D4 = Straight Ø4	
D6 = Straight Ø6	
D8 = Straight Ø8	
L1 = Female banjo G1/8"	
G4 = Rotating banjo Ø4	
G6 = Rotating banjo Ø6	
G8 = Rotating banjo Ø8	
M1 = G1/8" male	
M2 = G1/4" male	
F1 = G1/8" female	

Example: 551.141.D8.D8.D8

Circuit selector valve - OR. Connections "A", "B" and "C" Tube Ø8

NOTE : For the dimension including cartridges see page Accessories - Function fittings

**Construction characteristics**

- These valves have two inlets and one output connection and are normally called high pressure selector valves as, when receiving two separate pressure supply, only allow the passage of the highest pressure. The most common application is to operate a component from two separate positions.
- on DIN rail using the relevant adaptor kit (see accessories)
- With 90° bracket (see accessories)
- directly on the support plate thanks to two through holes on the body

Technical characteristics	
Fluid	Filtered air. No lubrication needed, if applied it shall be continuous
Working ports size	See CONNECTIONS LIST
Max working pressure (bar)	10
Flow rate at 6 bar with Δp=1 (Nl/min)	600
Temperature °C	-5 ÷ +50
Weight (g)	10

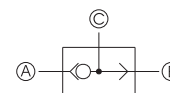

**Circuit selector valve - AND**

Coding: 551.151.A.B.C

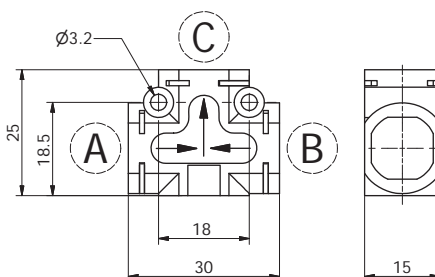

<b>A</b>	CONNECTION A <b>SEE CONNECTIONS LIST</b>
<b>B</b>	CONNECTION B <b>SEE CONNECTIONS LIST</b>
<b>C</b>	CONNECTION C <b>SEE CONNECTIONS LIST</b>
<b>CONNECTIONS LIST</b>	
00 = None	
D4 = Straight Ø4	
D6 = Straight Ø6	
D8 = Straight Ø8	
L1 = Female banjo G1/8"	
G4 = Rotating banjo Ø4	
G6 = Rotating banjo Ø6	
G8 = Rotating banjo Ø8	
M1 = G1/8" male	
M2 = G1/4" male	
F1 = G1/8" female	

Example: 551.151.D6.D6.D6

Circuit selector valve AND. Connections "A", "B" and "C" Tube Ø6

NOTE : For the dimension including cartridges see page Accessories - Function fittings

**Construction characteristics**

- These valves have two inlets and one output connection and are normally called low pressure selector valves as, when receiving two separate pressure supply, only allow the passage of the lowest pressure. The most common application is to operate a component from two separate positions.
- on DIN rail using the relevant adaptor kit (see accessories)
- With 90° bracket (see accessories)
- directly on the support plate thanks to two through holes on the body

Technical characteristics	
Fluid	Filtered air. No lubrication needed, if applied it shall be continuous
Working ports size	See CONNECTIONS LIST
Max working pressure (bar)	10
Flow rate at 6 bar with Δp=1 (Nl/min)	550
Temperature °C	-5 ÷ +50
Weight (g)	10

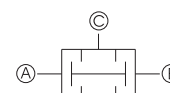

1  
AIR DISTRIBUTION

Quick exhaust valve

Coding: 551.161.A.B.XX

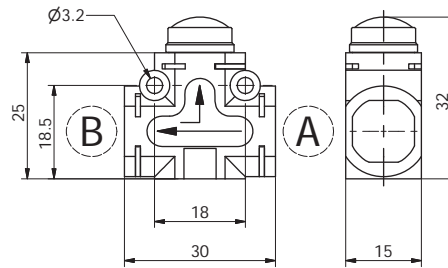

<b>A</b>	CONNECTION A <b>SEE CONNECTIONS LIST</b>
<b>B</b>	CONNECTION B <b>SEE CONNECTIONS LIST</b>
CONNECTIONS LIST	
00 = None	
D4 = Straight Ø4	
D6 = Straight Ø6	
D8 = Straight Ø8	
L1 = Female banjo G1/8"	
G4 = Rotating banjo Ø 4	
G6 = Rotating banjo Ø 6	
G8 = Rotating banjo Ø 8	
M1 = G1/8" male	
M2 = G1/4" male	
F1 = G1/8" female	

Example: 551.161.D8.D8.XX

Quick exhaust valve. Connections "A" and "B" Tube Ø6

NOTE : For the dimension including cartridges see page Accessories - Function fittings

Construction characteristics

- These are 3 ways, two positions valves which can be directly mounted onto the actuator or between the actuator and the control valve. Their function is to discharge the air directly into the atmosphere without going through the pneumatic circuit enabling the actuator to reach the maximum speed.
- on DIN rail using the relevant adaptor kit (see accessories)
- With 90° bracket (see accessories)
- directly on the support plate thanks to two through holes on the body

Technical characteristics	
Fluid	Filtered air. No lubrication needed, if applied it shall be continuous
Working ports size	See CONNECTIONS LIST
Max working pressure (bar)	10
Flow rate at 6 bar with $\Delta p=1$ (NI/min)	250
Flow rate at 6 bar with free exhaust (NI/min)	500
Temperature °C	-5 ÷ +50
Weight (g)	15

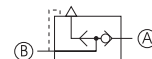

Pressure indicator

Coding: 551.178.A.B.XX

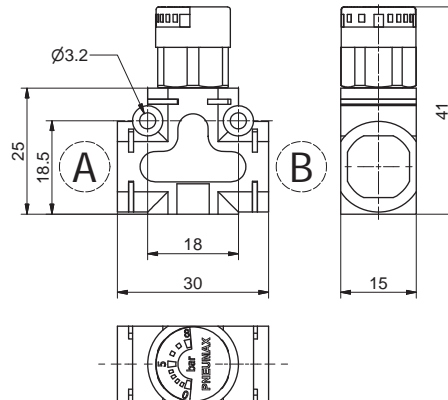

<b>A</b>	CONNECTION A <b>SEE CONNECTIONS LIST</b>
<b>B</b>	CONNECTION B <b>SEE CONNECTIONS LIST</b>
CONNECTIONS LIST	
00 = None	
D4 = Straight Ø4	
D6 = Straight Ø6	
D8 = Straight Ø8	
L1 = Female banjo G1/8"	
G4 = Rotating banjo Ø 4	
G6 = Rotating banjo Ø 6	
G8 = Rotating banjo Ø 8	
M1 = G1/8" male	
M2 = G1/4" male	
F1 = G1/8" female	

Example: 551.178.D6.D4.XX

Pressure indicator. Connections "A" Tube Ø6, "B" Tube Ø4

NOTE : For the dimension including cartridges see page Accessories - Function fittings

Construction characteristics

- The pressure visual indicator is a device which measures the pressure inside a pneumatic circuit. The 0 to 8 bar visual indicator makes very easy to monitor the pressure state inside the circuit. It can be use on its own or can be coupled with another device.
- It can be use on its own or can be coupled with another device.
- on DIN rail using the relevant adaptor kit (see accessories)
- With 90° bracket (see accessories)
- directly on the support plate thanks to two through holes on the body

Technical characteristics	
Fluid	Filtered air. No lubrication needed, if applied it shall be continuous
Working ports size	See CONNECTIONS LIST
Max working pressure (bar)	8
Visualization scale (bar)	0 ÷ 8
Temperature °C	-5 ÷ +50
Weight (g)	20.5

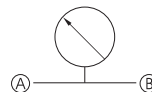

**In line progressive start-up valve**

Coding: 551.181.A.B.XX

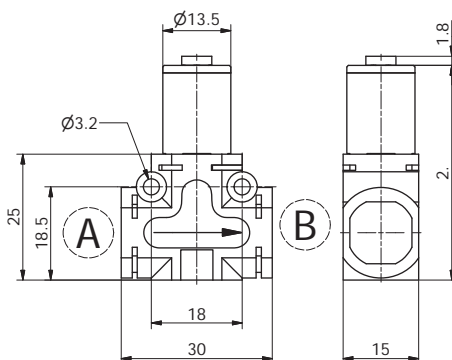

<b>A</b>	CONNECTION A <b>SEE CONNECTIONS LIST</b>
<b>B</b>	CONNECTION B <b>SEE CONNECTIONS LIST</b>
CONNECTIONS LIST	
	00 = None
	D4 = Straight Ø4
	D6 = Straight Ø6
	D8 = Straight Ø8
	L1 = Female banjo G1/8"
	G4 = Rotating banjo Ø4
	G6 = Rotating banjo Ø6
	G8 = Rotating banjo Ø8
	M1 = G1/8" male
	M2 = G1/4" male
	F1 = G1/8" female

Example: 551.181.D6.D4.XX

In line progressive start-up valve. Connections "A" Tube Ø6, "B" Tube Ø4

NOTE : For the dimension including cartridges see page Accessories - Function fittings

**Construction characteristics**

- The soft start valve is a device designed to gradually pressurise the downstream circuit until 50% of the upstream pressure value is reached.
- Once the 50% of the upstream pressure value is reached in the down stream circuit the valve fully opens allowing full air passage.
- The filling time can be adjusted thanks to the built in flow regulator.
- This device is used in order to ensure that during the pneumatic circuit start up the cylinders will return to theirs home position slowly avoiding collisions or sudden movements.

Technical characteristics	
Fluid	Filtered air. No lubrication needed, if applied it shall be continuous
Working ports size	See CONNECTIONS LIST
Opening pressure (Pa)	50% of the inlet pressure (Pi)
Flow rate at 6 bar with free exhaust (NI/min) from 1 to 2 with opening circuit	350
Flow rate at 6 bar with $\Delta p=1$ from 1 to 2 with opening circuit	600
Flow rate at 6 bar with $\Delta p=1$ from 2 to 1 with opening pin	650
Temperature °C	-5 ÷ +50
Weight (g)	31

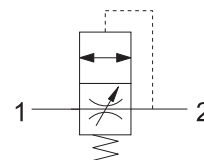

**90° progressive start-up valve**

Coding: 551.281.A.B.XX

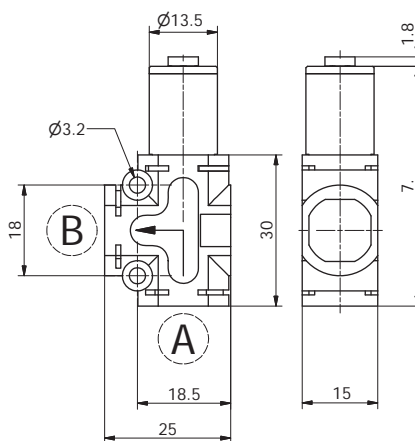

<b>A</b>	CONNECTION A <b>SEE CONNECTIONS LIST</b>
<b>B</b>	CONNECTION B <b>SEE CONNECTIONS LIST</b>
CONNECTIONS LIST	
	00 = None
	D4 = Straight Ø4
	D6 = Straight Ø6
	D8 = Straight Ø8
	L1 = Female banjo G1/8"
<b>L</b>	G4 = Rotating banjo Ø4
	G6 = Rotating banjo Ø6
	G8 = Rotating banjo Ø8
	M1 = G1/8" male
	M2 = G1/4" male
	F1 = G1/8" female

Example: 551.281.M1.D4.XX

90° progressive start-up valve. connections "A" Male G1/8", "B" Tube Ø4

NOTE : For the dimension including cartridges see page Accessories - Function fittings

**Construction characteristics**

- The soft start valve is a device designed to gradually pressurise the downstream circuit until 50% of the upstream pressure value is reached.
- Once the 50% of the upstream pressure value is reached in the down stream circuit the valve fully opens allowing full air passage.
- The filling time can be adjusted thanks to the built in flow regulator.
- This device is used in order to ensure that during the pneumatic circuit start up the cylinders will return to theirs home position slowly avoiding collisions or sudden movements.

Technical characteristics	
Fluid	Filtered air. No lubrication needed, if applied it shall be continuous
Working ports size	See CONNECTIONS LIST
Opening pressure (Pa)	50% of the inlet pressure (Pi)
Flow rate at 6 bar with free exhaust (NI/min) from 1 to 2 with opening circuit	350
Flow rate at 6 bar with $\Delta p=1$ from 1 to 2 with opening circuit	600
Flow rate at 6 bar with $\Delta p=1$ from 2 to 1 with opening pin	650
Temperature °C	-5 ÷ +50
Weight (g)	31

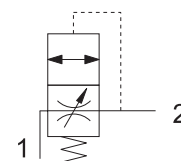

**In line blocking valve with flow control valve**

Coding: 551.1F<sup>T</sup>.A.B.XX

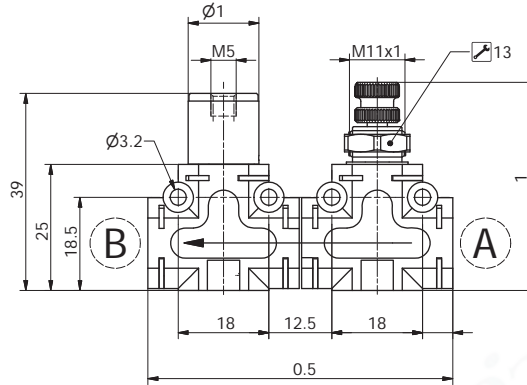

<b>TYPE</b>	1 = Unidirectional blocking valve + Unidirectional flow control valve
<b>2</b>	= Bidirectional blocking valve + Bidirectional flow control valve
<b>3</b>	= Unidirectional blocking valve + Bidirectional flow control valve
<b>4</b>	= Bidirectional blocking valve + Unidirectional flow control valve
<b>CONNECTION A</b>	SEE CONNECTIONS LIST
<b>CONNECTION B</b>	SEE CONNECTIONS LIST
<b>CONNECTIONS LIST</b>	
<b>00</b>	= None
<b>D4</b>	= Straight Ø4
<b>D6</b>	= Straight Ø6
<b>D8</b>	= Straight Ø8
<b>L1</b>	= Female banjo G1/8"
<b>G4</b>	= Rotating banjo Ø 4
<b>G6</b>	= Rotating banjo Ø 6
<b>G8</b>	= Rotating banjo Ø 8
<b>M1</b>	= G1/8" male
<b>M2</b>	= G1/4" male
<b>F1</b>	= G1/8" female

AIR DISTRIBUTION

Example: 551.1F1.00.00.XX

In line blocking valve + flow control valve. Without connections "A" and "B"

NOTE : For the dimension including cartridges see page Accessories - Function fittings

**Piloting curves**

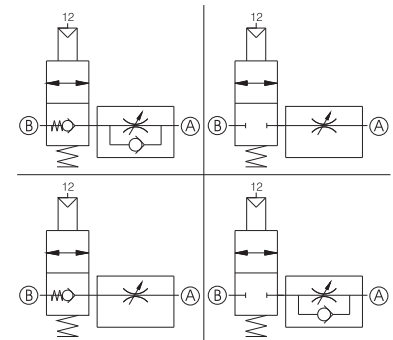
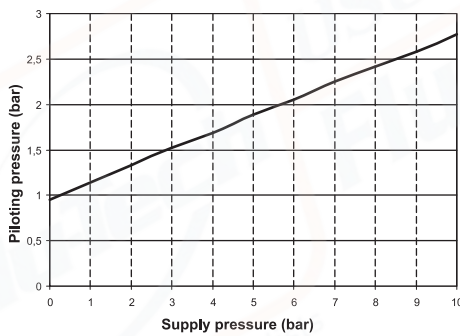

**Construction characteristics**

- The combination of this two functions ensures that the downstream pressure is maintained in case of accidental loss of supply pressure and at the same time grants the possibility to regulate the circuit flow rate. A typical application of this combination is close to or directly assembled onto the actuator connection ports. This allows to keep pressurised the cylinder chamber in case of accidental loss of supply pressure and to regulate the exhaust flow rate when the blocking valve is actuated.
- The possible combinations are the following:
  - Unidirectional blocking valve + unidirectional flow control valve
  - Bidirectional blocking valve + bidirectional flow control valve
  - Bidirectional blocking valve + unidirectional flow control valve
  - Unidirectional blocking valve + bidirectional flow control valve

**Technical characteristics**

Fluid	Filtered air. No lubrication needed, if applied it shall be continuous
Working ports size	See CONNECTIONS LIST
Max working pressure (bar)	0,5 ÷ 10
Flow rate at 6 bar with Δp=1 (NI/min)	285
Orifice size (mm)	Ø3
Temperature °C	-5 ÷ +50
Weight (g)	62

► 90° blocking valve + flow control valve

Coding: 551.2F<sup>T</sup>.A.B.XX

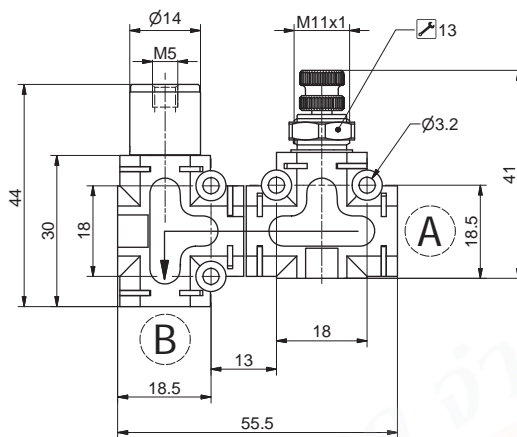

TYPE	1 = 90° Unidirectional blocking valve + Unidirectional flow control valve
	2 = 90° Bidirectional blocking valve + Bidirectional flow control valve
<b>T</b>	3 = 90° Unidirectional blocking valve + Bidirectional flow control valve
	4 = 90° Bidirectional blocking valve + Unidirectional flow control valve
<b>A</b>	CONNECTION A SEE CONNECTIONS LIST
<b>B</b>	CONNECTION B SEE CONNECTIONS LIST
CONNECTIONS LIST	
	00 = None
	D4 = Straight Ø4
	D6 = Straight Ø6
	D8 = Straight Ø8
	L1 = Female banjo G1/8"
	G4 = Rotating banjo Ø4
	G6 = Rotating banjo Ø6
	G8 = Rotating banjo Ø8
	M1 = G1/8" male
	M2 = G1/4" male
	F1 = G1/8" female

1  
AIR DISTRIBUTION

Example: 5512F1.00.00.XX  
90° blocking valve + flow control valve. Without connections "A" and "B"  
NOTE : For the dimension including cartridges see page Accessories - Function fittings

Piloting curves

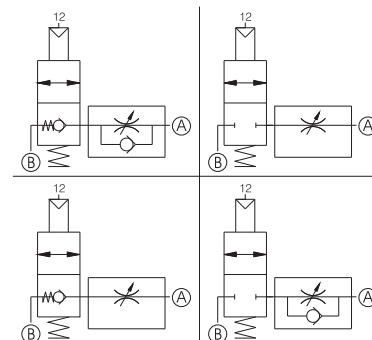
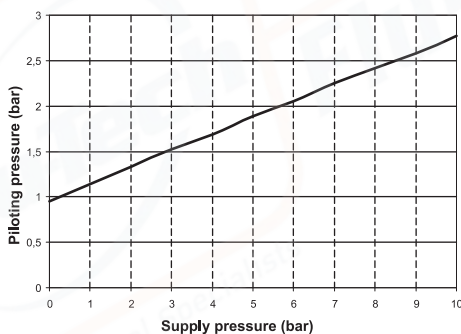

Construction characteristics

- The combination of this two functions ensures that the downstream pressure is maintained in case of accidental loss of supply pressure and at the same time grants the possibility to regulate the circuit flow rate. A typical application of this combination is close to or directly assembled onto the actuator connection ports. This allows to keep pressurised the cylinder chamber in case of accidental loss of supply pressure and to regulate the exhaust flow rate when the blocking valve is actuated.
- The possible combinations are the following:
  - 90° Unidirectional blocking valve + Unidirectional flow control valve
  - 90° Bidirectional blocking valve + Bidirectional flow control valve
  - 90° Bidirectional blocking valve + Unidirectional flow control valve
  - 90° Unidirectional blocking valve + Bidirectional flow control valve

Technical characteristics

Fluid	Filtered air. No lubrication needed, if applied it shall be continuous
Working ports size	See CONNECTIONS LIST
Max working pressure (bar)	0,5 ÷ 10
Flow rate at 6 bar with Δp=1 (Nl/min)	285
Orifice size (mm)	Ø3
Temperature °C	-5 ÷ +50
Weight (g)	62

In line blocking valve + quick exhaust valve

Coding: 551.1G<sup>T</sup>.A.B.XX

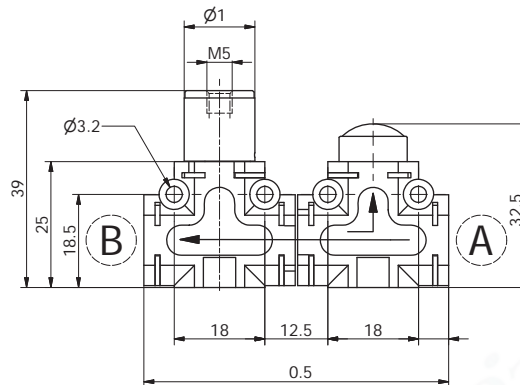

TYPE	
1	= Unidirectional blocking valve + quick exhaust valve
2	= Bidirectional blocking valve + quick exhaust valve
CONNECTION A	
SEE CONNECTIONS LIST	
CONNECTION B	
SEE CONNECTIONS LIST	
CONNECTIONS LIST	
00	= None
D4	= Straight Ø4
D6	= Straight Ø6
D8	= Straight Ø8
L1	= Female banjo G1/8"
G4	= Rotating banjo Ø 4
G6	= Rotating banjo Ø 6
G8	= Rotating banjo Ø 8
M1	= G1/8" male
M2	= G1/4" male
F1	= G1/8" female

1  
AIR DISTRIBUTION

Example: 5511G1.00.00.XX

In line blocking valve + quick exhaust valve. Without connections "A" and "B"

NOTE : For the dimension including cartridges see page Accessories - Function fittings

Piloting curves

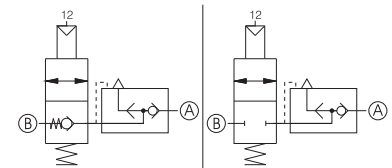
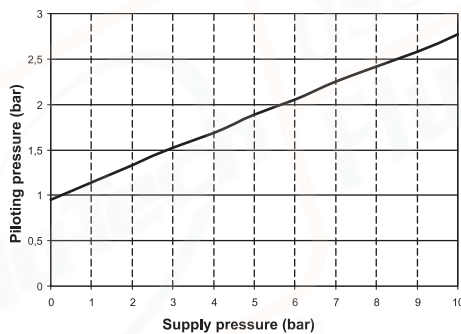

Construction characteristics

- The combination of this two functions ensures that the downstream pressure is maintained in case of accidental loss of supply pressure and at the same time allows for the air to be directly discharged into the atmosphere without going through the pneumatic circuit. A typical application of this combination is close to or directly assembled onto the actuator connection ports. This allows to keep pressurised the cylinder chamber in case of accidental loss of supply pressure and to quickly discharge the same chamber when the blocking valve is actuated.
- The possible combinations are the following:
  - Unidirectional blocking valve + quick exhaust valve
  - Bidirectional blocking valve + quick exhaust valve

Technical characteristics

Fluid	Filtered air. No lubrication needed, if applied it shall be continuous
Working ports size	See CONNECTIONS LIST
Max working pressure (bar)	0.5 ÷ 10
Flow rate at 6 bar with Δp=1 (NI/min)	285
Temperature °C	-5 ÷ +50
Weight (g)	51

▶ 90° blocking valve + quick exhaust valve

Coding: 551.2G<sup>T</sup>.A.B.XX

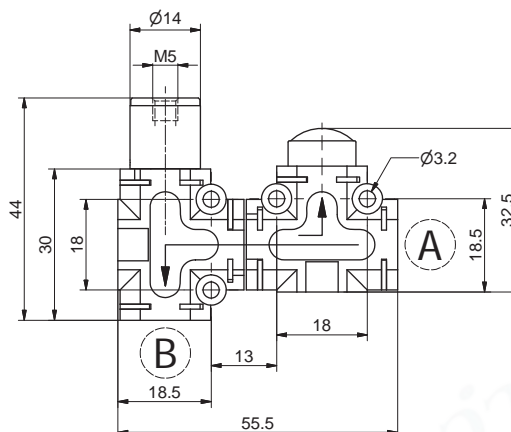

TYPE	1 = 90° Unidirectional blocking valve + quick exhaust valve
<b>T</b>	2 = 90° Bidirectional blocking valve + quick exhaust valve
<b>A</b>	CONNECTION A SEE CONNECTIONS LIST
<b>B</b>	CONNECTION B SEE CONNECTIONS LIST
CONNECTIONS LIST	
00	= None
D4	= Straight Ø4
D6	= Straight Ø6
D8	= Straight Ø8
L1	= Female banjo G1/8"
G4	= Rotating banjo Ø4
G6	= Rotating banjo Ø6
G8	= Rotating banjo Ø8
M1	= G1/8" male
M2	= G1/4" male
F1	= G1/8" female

Example: 551.2G1.00.00.XX  
90° bidirectional blocking valve + quick exhaust valve. Without connections "A" and "B"  
NOTE : For the dimension including cartridges see page Accessories - Function fittings

Piloting curves

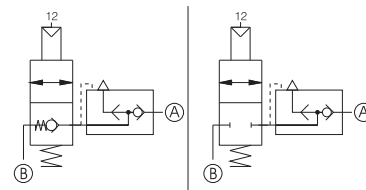
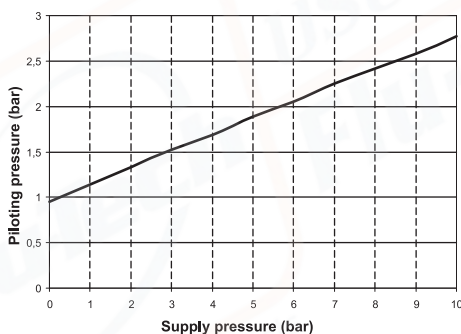

Construction characteristics

- The combination of this two functions ensures that the downstream pressure is maintained in case of accidental loss of supply pressure and at the same time allows for the air to be directly discharged into the atmosphere without going through the pneumatic circuit. A typical application of this combination is close to or directly assembled onto the actuator connection ports. This allows to keep pressurised the cylinder chamber in case of accidental loss of supply pressure and to quickly discharge the same chamber when the blocking valve is actuated.
- The possible combinations are the following:
  - 90° Unidirectional blocking valve + quick exhaust valve
  - 90° Bidirectional blocking valve + quick exhaust valve

Technical characteristics

Fluid	Filtered air. No lubrication needed, if applied it shall be continuous
Working ports size	See CONNECTIONS LIST
Max working pressure (bar)	0,5 ÷ 10
Flow rate at 6 bar with Δp=1 (NI/min)	285
Temperature °C	-5 ÷ +50
Weight (g)	51

1  
AIR DISTRIBUTION

**In line pressure regulator + pressure indicator**

Coding: 551.1H**T**.**A**.**B**.XX

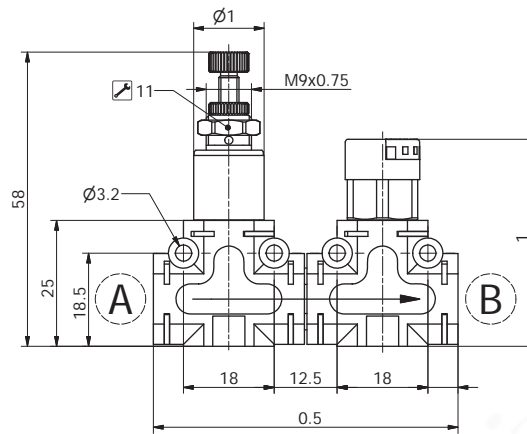

TYPE	
<b>T</b>	2 = 0-2 bar
	4 = 0-4 bar
	8 = 0-8 bar
CONNECTION A	
<b>A</b>	SEE CONNECTIONS LIST
CONNECTION B	
<b>B</b>	SEE CONNECTIONS LIST
CONNECTIONS LIST	
<b>00</b>	= None
<b>D4</b>	= Straight $\varnothing 4$
<b>D6</b>	= Straight $\varnothing 6$
<b>D8</b>	= Straight $\varnothing 8$
<b>L1</b>	= Female banjo G1/8"
<b>G4</b>	= Rotating banjo $\varnothing 4$
<b>G6</b>	= Rotating banjo $\varnothing 6$
<b>G8</b>	= Rotating banjo $\varnothing 8$
<b>M1</b>	= G1/8" male
<b>M2</b>	= G1/4" male
<b>F1</b>	= G1/8" female

Example: 551.1H2.M1.D4.XX

In line pressure regulator, adjusting range 0 - 2 bar + pressure indicator. Connections "A" Male G 1/8 and "B" Tube  $\varnothing 4$

NOTE : For the dimension including cartridges see page Accessories - Function fittings

**Construction characteristics**

- The combination of this two functions ensures the possibility to regulate the downstream pressure while directly visualising the adjusted pressure value.
- The possible combinations are the following:
  - 0 to 2 bar pressure regulator + pressure visual indicator
  - 0 to 4 bar pressure regulator + pressure visual indicator
  - 0 to 8 bar pressure regulator + pressure visual indicator
- The visual indicator Pressure range (bar) is always 0 to 8 bar

Technical characteristics	
Fluid	Filtered air. No lubrication needed, if applied it shall be continuous
Working ports size	See CONNECTIONS LIST
Max working pressure (bar)	8
Visualization scale (bar)	0 ÷ 8
Pressure range (bar)	0 ÷ 2
	0 ÷ 4
	0 ÷ 8
Temperature °C	-5 ÷ +50
Weight (g)	62

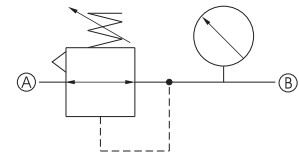

**90° pressure regulator + pressure indicator**

Coding: 551.2H**T**.**A**.**B**.XX

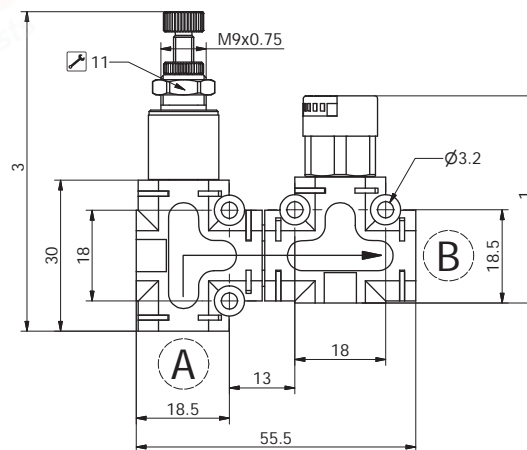

TYPE	
<b>T</b>	2 = 0-2 bar
	4 = 0-4 bar
	8 = 0-8 bar
CONNECTION A	
<b>A</b>	SEE CONNECTIONS LIST
CONNECTION B	
<b>B</b>	SEE CONNECTIONS LIST
CONNECTIONS LIST	
<b>00</b>	= None
<b>D4</b>	= Straight $\varnothing 4$
<b>D6</b>	= Straight $\varnothing 6$
<b>D8</b>	= Straight $\varnothing 8$
<b>L1</b>	= Female banjo G1/8"
<b>G4</b>	= Rotating banjo $\varnothing 4$
<b>G6</b>	= Rotating banjo $\varnothing 6$
<b>G8</b>	= Rotating banjo $\varnothing 8$
<b>M1</b>	= G1/8" male
<b>M2</b>	= G1/4" male
<b>F1</b>	= G1/8" female

Example: 551.2H2.M1.D4.XX

90° pressure regulator, adjusting range 0 - 2 bar + pressure indicator. Connections "A" Male G 1/8 and "B" Tube  $\varnothing 4$

NOTE : For the dimension including cartridges see page Accessories - Function fittings

**Construction characteristics**

- The combination of this two functions ensures the possibility to regulate the downstream pressure while directly visualising the adjusted pressure value.
- The possible combinations are the following:
  - 0 to 2 bar pressure regulator + pressure visual indicator
  - 0 to 4 bar pressure regulator + pressure visual indicator
  - 0 to 8 bar pressure regulator + pressure visual indicator
- The visual indicator Pressure range (bar) is always 0 to 8 bar

Technical characteristics	
Fluid	Filtered air. No lubrication needed, if applied it shall be continuous
Working ports size	See CONNECTIONS LIST
Max working pressure (bar)	8
Visualization scale (bar)	0 ÷ 8
Pressure range (bar)	0 ÷ 2
	0 ÷ 4
	0 ÷ 8
Temperature °C	-5 ÷ +50
Weight (g)	62

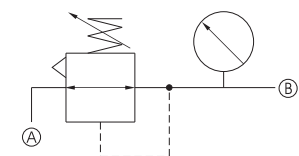

**Coupling kit (pins and forks)**

Coding: 55160

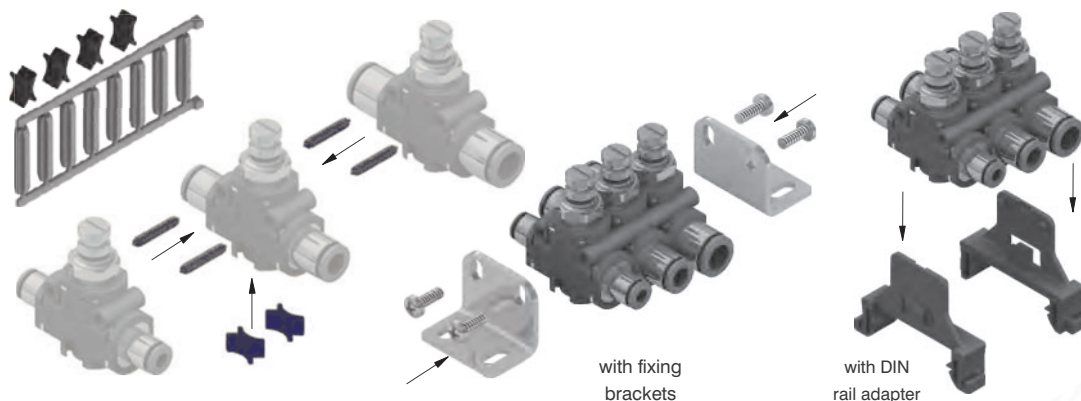

- Weight 2,5 g
- The kit, which includes a series of pins and forks, enables to join together in a fast and safe way the function fittings. The pins, once inserted in the front holes, ensure resistance against forces applied perpendicularly and sideways (for example the insertion of the tube in the cartridges).
- The forks, once located in the profiled housing ensures that the parts are held together tightly.
- The kit allows for 5 function fittings to be mounted together.

**Fixing brackets**

**DIN rail adapter**

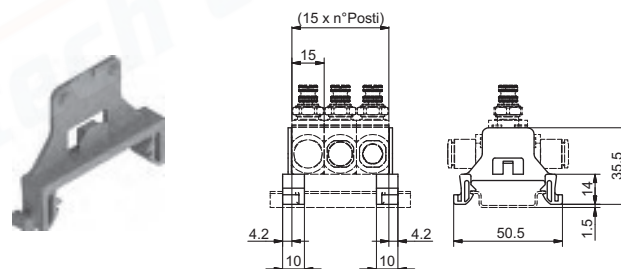
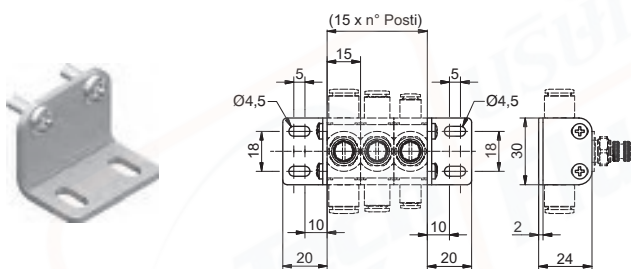

Coding: 55150

Weight 18 g  
The kit comprises two fixing brackets and the screws

Coding: 55116

Weight 4 g  
The kit comprises two adapters

**Ø4, Ø6 & Ø8 straight cartridge**

Coding: 551KD<sup>Ⓢ</sup>



CONNECTIONS	
Ⓢ	4 = tube Ø4
Ⓢ	6 = tube Ø6
Ⓢ	8 = tube Ø8

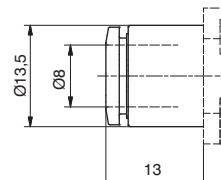
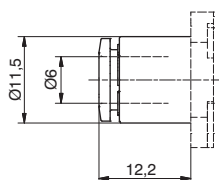
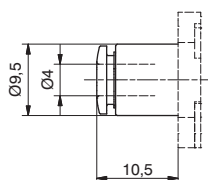

Weight 7,5 g

551KD4

Weight 7,3 g

551KD6

Weight 7 g

551KD8



AIR DISTRIBUTION

► Ø4, Ø6 & Ø8 banjo PL cartridge

Coding: 551KG<sup>Ⓢ</sup>

CONNECTIONS	
Ⓢ	4 = tube Ø4
	6 = tube Ø6
	8 = tube Ø8

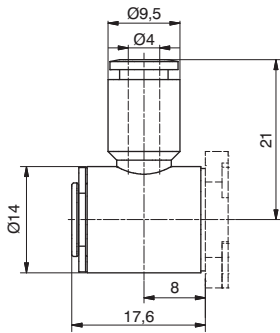

Weight 13,6 g

551KG4

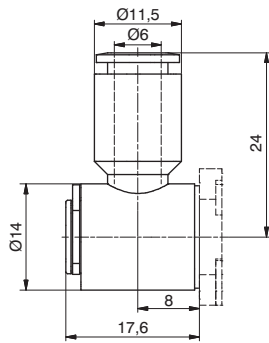

Weight 14 g

551KG6

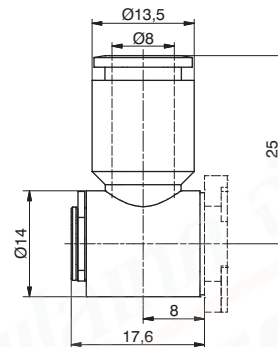

Weight 14,3 g

551KG8

► G1/8" banjo artridge

Coding: 551KL<sup>Ⓢ</sup>

CONNECTIONS	
Ⓢ	1 = G1/8"

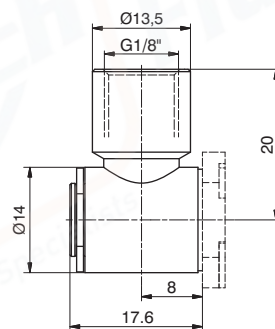

Weight 30 g

551KL1

► Connection for multiple function



Coding: 551KUU

Weight 14 g

► Cartridge

Coding: 551K<sup>Ⓢ</sup>

CONNECTIONS	
Ⓢ	M1 = G1/8" male straight cartridge
	M2 = G1/4" male straight cartridge
	F1 = G1/8" female straight cartridge

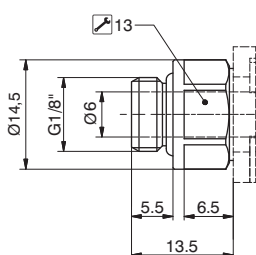

Weight 14 g  
G1/8" male straight cartridge

551KM1

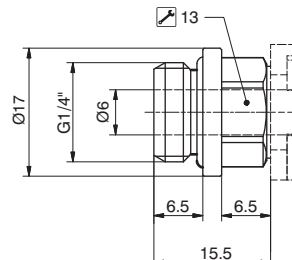

Weight 20 g  
G1/4" male straight cartridge

551KM2

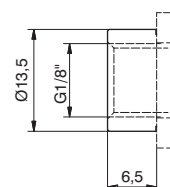

Weight 9 g  
G1/8" female straight cartridge

551KF1