

## Series 2500 "OPTYMA-F"

### General

The solenoid valves base mounted line including electrical connection into the manifold.  
Many technical features make the new product interesting:

- Flow rate of 1000 Nl/min
- Low consumption coils placed all in one side of the valve
- Quick mounting of the valve to the base using just one screw
- Quick connection of the bases thanks to 180 degree rotating pins
- Possibility to use different pressures along the manifold (including vacuum)
- IP65 environmental protection
- Electrical connection directly integrated into the base, 32 electrical signals available (can be used to build up a manifold of 32 monostable valves, 16 bistable valves or any combination within that limit).
- The electrical connection is made via 37 pin D-SUB connector.
- It is also available a 25-pole connector that is able to manage a maximum number of 22 electrical signals.

Possibility to integrate with Field Bus modules CANopen®, PROFIBUS DP, DeviceNet, EtherNet/IP, PROFINET IO RT/IRT, EtherCAT®, Powerlink and Modbus/TCP.

Possibility to connect input modules, even on the base that does not have the Field Bus module. Large use of technopolymer material reduces the overall weight of the manifold.

**"Shifting time of pneumatic directional control valves or moving parts, logic devices were measured in accordance to ISO 12238:2001, Pneumatic fluid power-Directional control valves-Measurement of shifting time"**

### Main characteristics

Integrated and optimized electrical connection system.  
IP65 protection degree.  
Only one 19mm size  
Electrical line connections on one side  
Monostable and bistable solenoid valves with the same size dimensions.  
Easy and fast manifold assembly

### Construction characteristics

Body	Technopolymer
Operators	Technopolymer
Spacers	NBR
Spacer	Technopolymer
Spools	Nickel - plated steel / Technopolymer
Springs	AISI 302 stainless steel
Pistons	Technopolymer
Piston seals	NBR

### Functions

SV 5/2 MONOSTABLE SOLENOID-SPRING  
SV 5/2 MONOSTABLE SOLENOID-DIFFERENTIAL  
SV 5/2 BISTABLE SOLENOID-SOLENOID  
SV 5/3 C.C. SOLENOID-SOLENOID  
SV 2x3/2 N.C.-N.C. (=5/3 O.C.) SOLENOID-SOLENOID  
SV 2x3/2 N.O.-N.O. (=5/3 P.C.) SOLENOID-SOLENOID  
SV 2x3/2 N.C.-N.O. SOLENOID-SOLENOID

### Technical characteristics

Voltage	24VDC ±10% PNP (NPN and AC on request)
Pilot consumption	1,3 Watt
Pilot working pressure (12-14)	From 3 to 7 bar max.
Valve working pressure [1]	from vacuum up to 10 bar
Operating temperature	-5°C +50°C
Protection degree	IP65
Life (standard operating conditions)	50000000
Fluid	Filtered air. No lubrication needed, if applied it shall be continuous





**Solenoid - Spring**

Coding: 2531.52.00.39. ✓

Operational characteristics	
Fluid	Filtered air. No lubrication needed, if applied it shall be continuous
Working pressure (bar)	From vacuum to 10
Pressure range (bar)	3 ÷ 7
Temperature °C	-5 ÷ +50
Flow rate at 6 bar with Δp=1 (NI/min)	1000
Response time according to ISO 12238, activation time (ms)	14
Response time according to ISO 12238, deactivation time (ms)	40

VOLTAGE
02 = 24 VDC PNP
12 = 24 VDC NPN
05 = 24 VAC

SHORT FUNCTION CODE "A"  
Weight 123 g

Shifting time of pneumatic directional control valves or moving parts, logic devices were measured in accordance to ISO 12238:2001

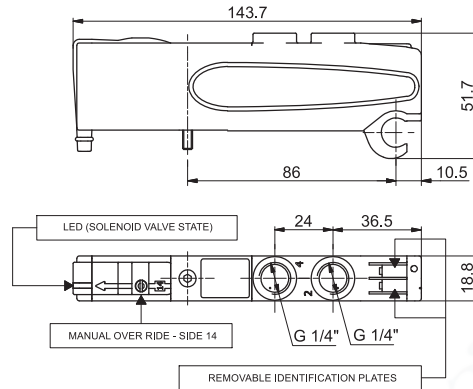

**Solenoid-Differential**

Coding: 2531.52.00.36. ✓

Operational characteristics	
Fluid	Filtered air. No lubrication needed, if applied it shall be continuous
Working pressure (bar)	From vacuum to 10
Pressure range (bar)	3 ÷ 7
Temperature °C	-5 ÷ +50
Flow rate at 6 bar with Δp=1 (NI/min)	1000
Response time according to ISO 12238, activation time (ms)	20
Response time according to ISO 12238, deactivation time (ms)	29

VOLTAGE
02 = 24 VDC PNP
12 = 24 VDC NPN
05 = 24 VAC

SHORT FUNCTION CODE "B"  
Weight 120 g

Shifting time of pneumatic directional control valves or moving parts, logic devices were measured in accordance to ISO 12238:2001

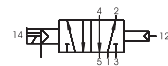
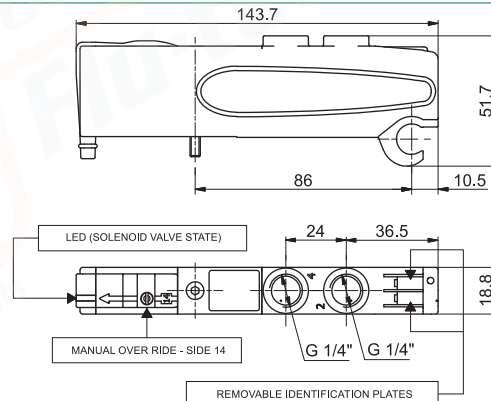

**Solenoid-Solenoid**

Coding: 2531.52.00.35. ✓

Operational characteristics	
Fluid	Filtered air. No lubrication needed, if applied it shall be continuous
Working pressure (bar)	From vacuum to 10
Pressure range (bar)	3 ÷ 7
Temperature °C	-5 ÷ +50
Flow rate at 6 bar with Δp=1 (NI/min)	1000
Response time according to ISO 12238, activation time (ms)	10
Response time according to ISO 12238, deactivation time (ms)	14

VOLTAGE
02 = 24 VDC PNP
12 = 24 VDC NPN
05 = 24 VAC

SHORT FUNCTION CODE "C"  
Weight 128 g

Shifting time of pneumatic directional control valves or moving parts, logic devices were measured in accordance to ISO 12238:2001

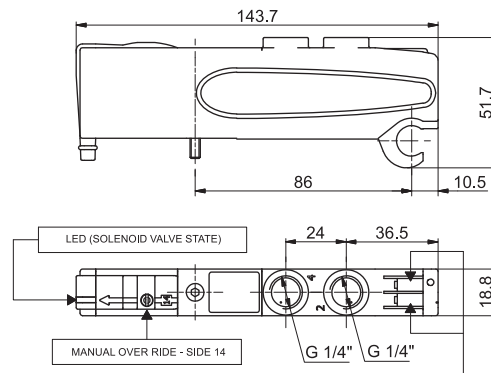

**Solenoid-Solenoid 5/3**

Coding: 2531.53.31.35.

Operational characteristics	
Fluid	Filtered air. No lubrication needed, if applied it shall be continuous
Working pressure (bar)	From vacuum to 10
Pressure range (bar)	3 ÷ 7
Temperature °C	-5 ÷ +50
Flow rate at 6 bar with Δp=1 (NI/min)	600
Response time according to ISO 12238, activation time (ms)	15
Response time according to ISO 12238, deactivation time (ms)	20

VOLTAGE
02 = 24 VDC PNP
12 = 24 VDC NPN
05 = 24 VAC
SHORT FUNCTION CODE "E"
Weight 126 g

Shifting time of pneumatic directional control valves or moving parts, logic devices were measured in accordance to ISO 12238:2001

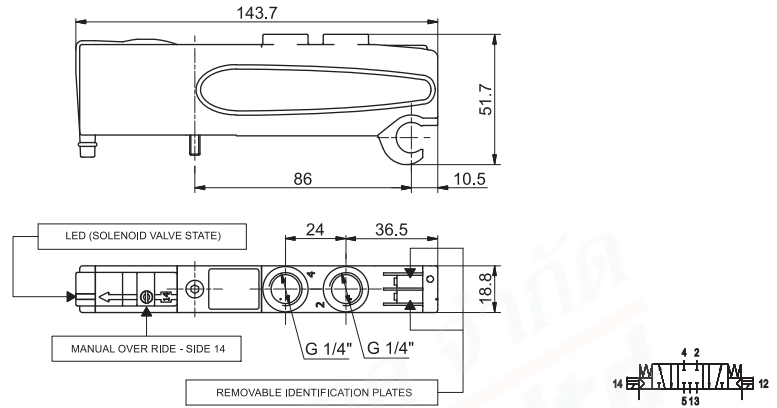

1  
AIR DISTRIBUTION

**Solenoid-Solenoid 2x3/2**

Coding: 2531.62. .35.

Operational characteristics	
Fluid	Filtered air. No lubrication needed, if applied it shall be continuous
Working pressure (bar)	From vacuum to 10
Pressure range (bar)	≥2,5+(0,2xP.alim.)
Temperature °C	-5 ÷ +50
Flow rate at 6 bar with Δp=1 (NI/min)	700
Response time according to ISO 12238, activation time (ms)	15
Response time according to ISO 12238, deactivation time (ms)	25

FUNCTION
44 = NC-NC (5/3 Open centres)
55 = NO-NO (5/3 Pressured centres)
45 = N.C.-N.O. (normally closed-normally open)
54 = N.O.-N.C. (normally open-normally closed)
VOLTAGE
02 = 24 VDC PNP
12 = 24 VDC NPN
05 = 24 VAC

SHORT FUNCTION CODE:  
NC-NC (5/3 Open centres) = "F"  
NO-NO (5/3 Pressured centres) = "G"  
NC-NO = "H"  
NO-NC = "I"  
Weight 115,5 g

Shifting time of pneumatic directional control valves or moving parts, logic devices were measured in accordance to ISO 12238:2001

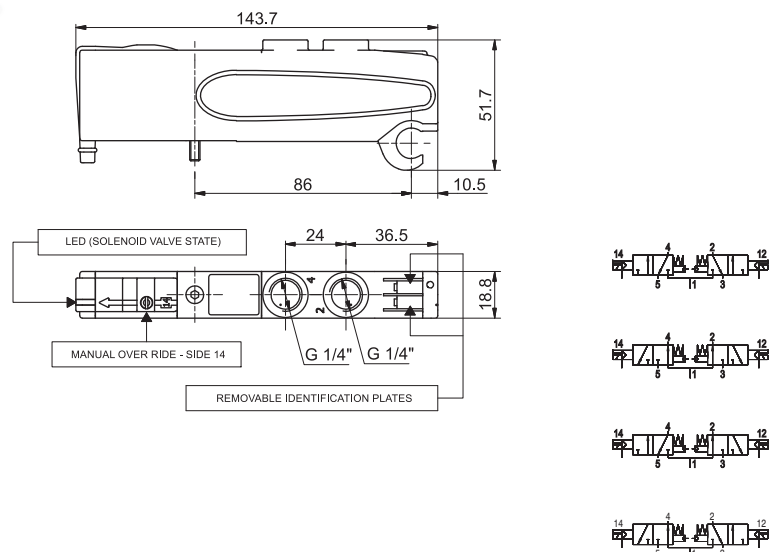



Left Endplates

Coding: 2530.V.C

Operational characteristics	
Fluid	Filtered air. No lubrication needed, if applied it shall be continuous
Working pressure (bar)	From vacuum to 10 (External pilot base only)
Pressure range (bar)	3 ÷ 7
Temperature °C	-5 ÷ +50

VERSION	
V	02 = External feeding
	12 = Self-feeding
ELECTRICAL CONNECTION	
37P	= Connectors 37 poles PNP
25P	= Connectors 25 poles PNP
37N	= Connectors 37 poles NPN
C	25N = Connectors 25 poles NPN
	37A = Connectors 37 poles AC
	25A = Connectors 25 poles AC
	C16 = Terminal 16 signals PNP

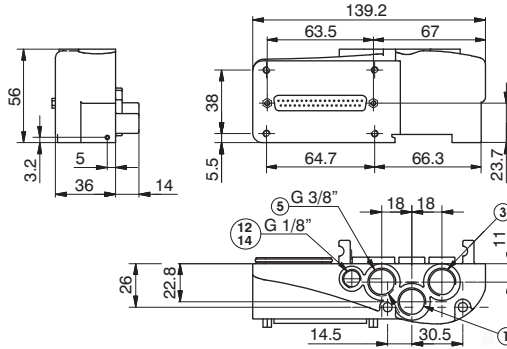

Weight 206 g

2530.02.C

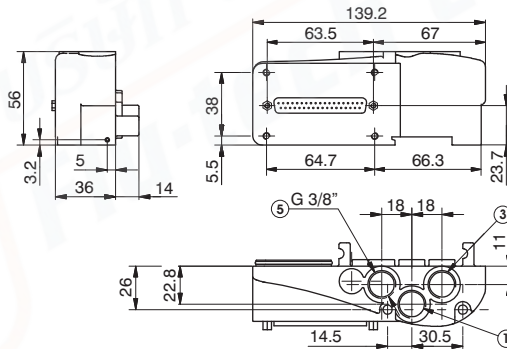

Weight 206 g

2530.12.C

Right Endplates

Coding: 2530.03.C

Operational characteristics	
Fluid	Filtered air. No lubrication needed, if applied it shall be continuous
Working pressure (bar)	From vacuum to 10
Temperature °C	-5 ÷ +50

ELECTRICAL CONNECTION	
C	00 = Electrical connection
	25P = Connectors 25 poles

Weight 181,5 g

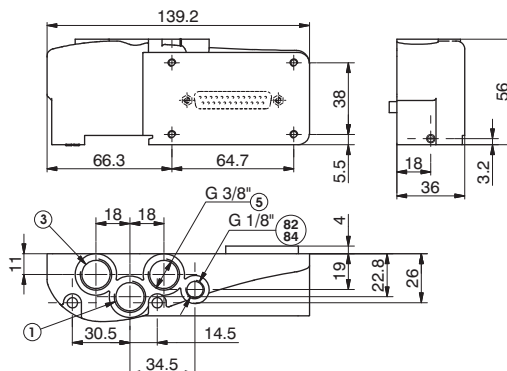

PORT 82/84= DO NOT PRESSURIZE, SOLENOID PILOTS EXHAUST

AIR DISTRIBUTION 1

**Closing plate**

Coding: 2530.00

Operational characteristics	
Fluid	Filtered air. No lubrication needed, if applied it shall be continuous
Working pressure (bar)	From vacuum to 10
Temperature °C	-5 ÷ +50

SHORT FUNCTION CODE "T"  
Weight 53,5 g

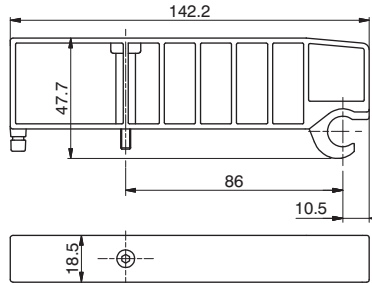

**Modular base**

Coding: 2530.01

Operational characteristics	
Fluid	Filtered air. No lubrication needed, if applied it shall be continuous
Working pressure (bar)	From vacuum to 10
Temperature °C	-5 ÷ +50

VERSION	
<input checked="" type="checkbox"/>	<b>M</b> = for Monostable SV
<input type="checkbox"/>	<b>B</b> = for Bistable SV

SHORT CODE "1" (per EV Monostabile)  
SHORT CODE "2" (per EV Bistabile)  
Weight 91,5 g

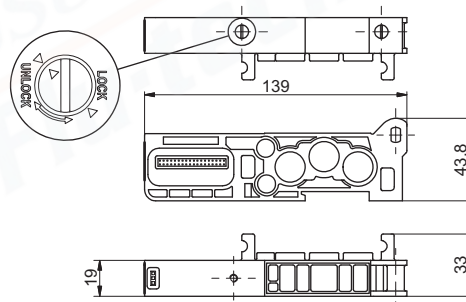

**Intermediate Inlet/Exhaust module**

Coding: 2530.10

Operational characteristics	
Fluid	Filtered air. No lubrication needed, if applied it shall be continuous
Working pressure (bar)	From vacuum to 10
Temperature °C	-5 ÷ +50

SHORT FUNCTION CODE "W"  
Weight 110 g

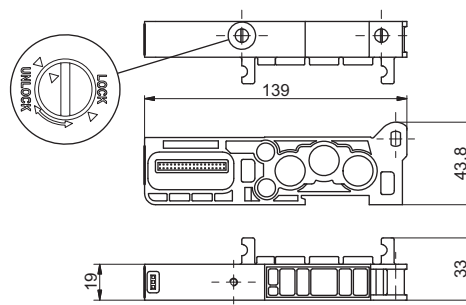

**General :**

Each Optyma-F manifold lets to manage 32 command signals for the valves. Optyma-F serial nodes (CANopen®, DeviceNet, PROFIBUS DP, EtherCAT®, PROFINET IO RT, EtherNet/IP and Powerlink) have a single pin for the power supply of the solenoid valves. So if you want to interrupt the power supply of one valve it is necessary to interrupt all the valves. The additional power supply module lets to interrupt at the same time the first 2 available command signals for the valves after the module itself. The additional power supply module is particularly useful also when you use control signals that block the valves. This application is effective both with serial management and multi-pole connection of the manifolds. This module is inserted directly into the Optyma-F solenoid valves manifold.

**Ordering code**

**2530.10.2A**

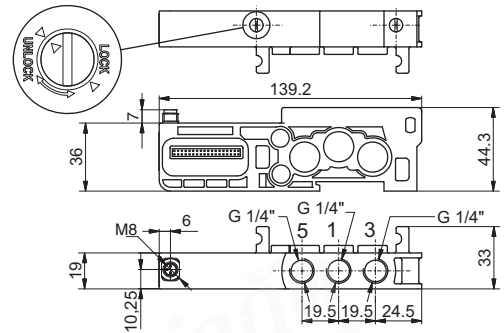

In particular this module is fitted with a M8 3 pins connector: +24V, not connected, GND.



PIN	DESCRIPTION
1	+24 VDC
4	NOT CONNECTED
3	GND

**WORKING PRINCIPLE / SIMPLIFIED FUNCTIONAL DIAGRAM**

This module uses an external power supply (+24VDC) to manage the solenoid valves.

The output signal from serial node / multi-pole connection is used as command signal: when it is high the +24VDC will be present at the module output.

If you want to cut off the power supply to a group of 2 valves it is sufficient to take away the +24VDC provided to the module by the M8 connector.

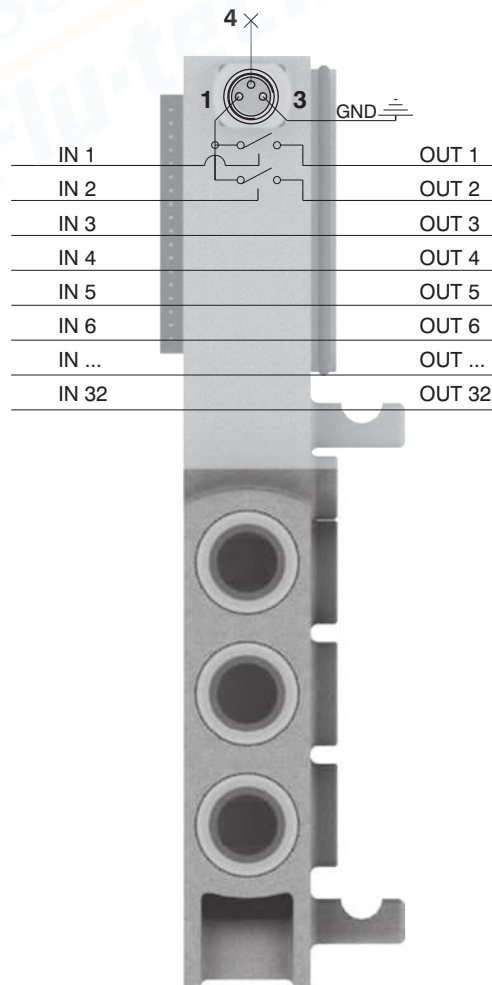

**Please note:** It is possible to use more modules to interrupt all the command signals, simply by inserting them before the signals to interrupt and after the signals already interrupted.

**Usage examples:**

**EXAMPLE 1:**

Manifold of 12 monostable valves on which you want to interrupt signals 7-8

**Assembly:**

- 6 monostable valves (not interruptible because before the module),
- 1 additional power supply module,
- 6 monostable valves. Please note: the first 2 monostable of these are interruptible by the module, while the following 4 will work correctly managed directly by the corresponding command signals.

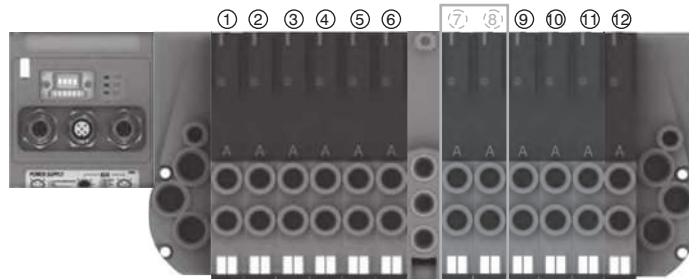

**EXAMPLE 2:**

Manifold of 12 monostable valves on which you want to interrupt signal 9

**Assembly:**

- 8 monostable valves (not interruptible because before the module),
- 1 additional power supply module,
- 1 monostable valve (interruptible),
- 1 closing plate mounted on a monostable base,
- 3 monostable valves (work correctly managed directly by the corresponding command signals).

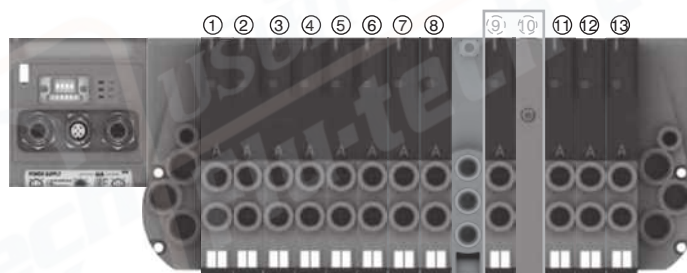

**Please note:** Each additional power supply module interrupts always 2 electrical signals.

If you need to interrupt less than 2 signals you can:

- assemble the valves to interrupt in the last positions of the manifold, so you don't need to worry about the interrupted exceeding signals;
- use a bistable base and mount a monostable valve (for each signal less than the 2 standard);
- use a monostable base and mount a closing plate (for each signal less than the 2 standard).

**EXAMPLE 3:**

Manifold of 7 monostable e 3 bistable valves on which you want to interrupt signals 2-3 and 8-9.

**Assembly:**

- 1 monostable valve (not interruptible because before the module),
- 1 additional power supply module,
- 6 monostable valves.

Please note: the first 2 monostable of these are interruptible by the module, while the following 4 will work correctly managed directly by the corresponding command signals.

- 1 additional power supply module,
- 3 bistable valves.

**Please note:** the first bistable of these valves is interruptible by the module, while the following 2 will work correctly managed directly by the corresponding command signals.

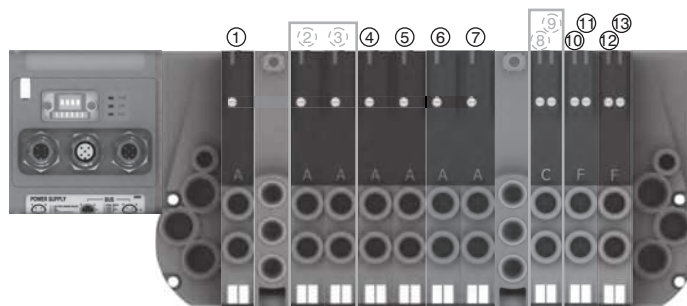

**General :**

Each Optyma-F manifold lets to manage 32 command signals for the valves. Optyma-F serial nodes (CANopen®, DeviceNet, PROFIBUS DP, EtherCAT®, PROFINET IO RT, EtherNet/IP and Powerlink) have a single pin for the power supply of the solenoid valves. So if you want to interrupt the power supply of one valve it is necessary to interrupt all the valves. The additional power supply module lets to interrupt at the same time the first 4 available command signals for the valves after the module itself. The additional power supply module is particularly useful also when you use control signals that block the valves. This application is effective both with serial management and multi-pole connection of the manifolds. This module is inserted directly into the Optyma-F solenoid valves manifold.

**Ordering code**

**2530.10.4A**

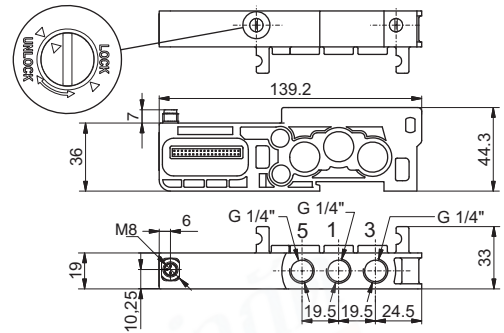

In particular this module is fitted with a M8 3 pins connector: +24V, not connected, GND.

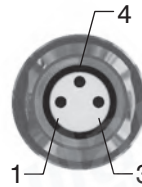

PIN	DESCRIPTION
1	+24 VDC
4	NOT CONNECTED
3	GND

**WORKING PRINCIPLE / SIMPLIFIED FUNCTIONAL DIAGRAM**

This module uses an external power supply (+24VDC) to manage the solenoid valves.

The output signal from serial node / multi-pole connection is used as command signal: when it is high the +24VDC will be present at the module output.

If you want to cut off the power supply to a group of 4 valves it is sufficient to take away the +24VDC provided to the module by the M8 connector.

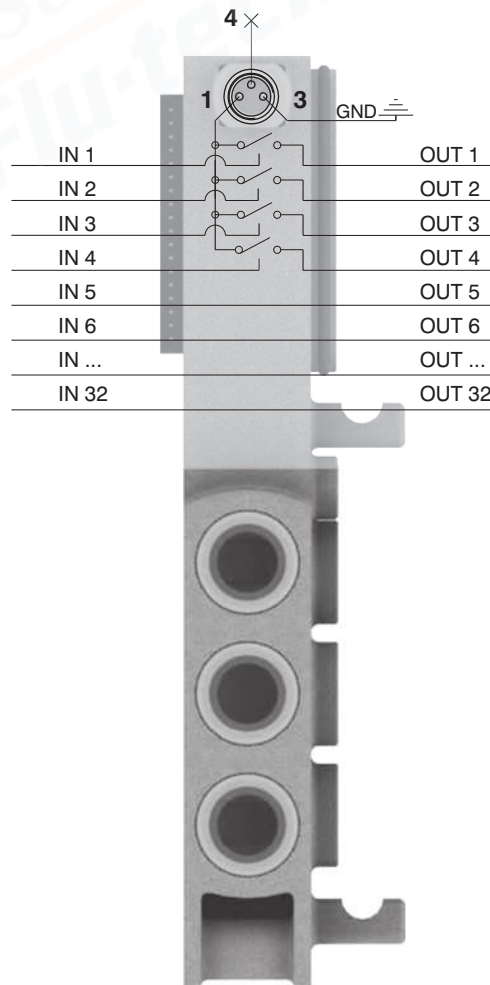

**Please note:** It is possible to use more modules to interrupt all the command signals, simply by inserting them before the signals to interrupt and after the signals already interrupted.

AIR DISTRIBUTION 1

**Usage examples:**

**EXAMPLE 1:**

Manifold of 12 monostable valves on which you want to interrupt signals 7-8-9-10

**Assembly:**

- 6 monostable valves (not interruptible because before the module),
- 1 additional power supply module,
- 6 monostable valves. Please note: the first 4 monostable of these are interruptible by the module, while the following 2 will work correctly managed directly by the corresponding command signals.

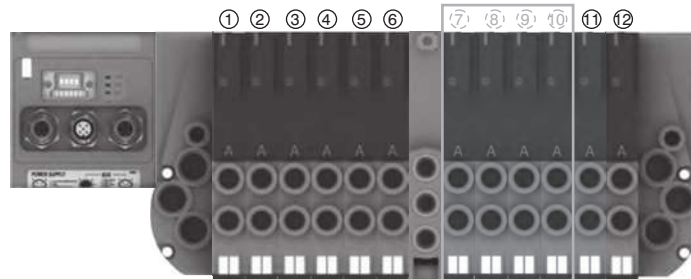

**EXAMPLE 2:**

Manifold of 12 monostable valves on which you want to interrupt signals 7-8-9

**Assembly:**

- 6 monostable valves (not interruptible because before the module),
- 1 additional power supply module,
- 3 monostable valves (interruptible),
- 1 closing plate mounted on a monostable base,
- 3 monostable valves (work correctly managed directly by the corresponding command signals).

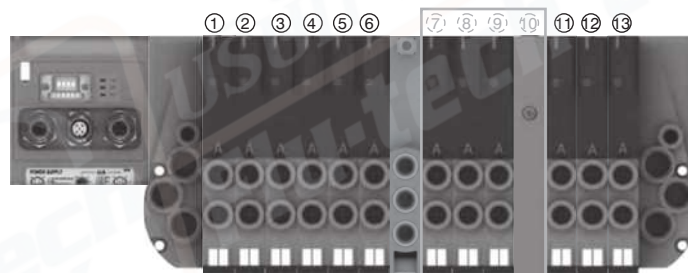

**Please note:** Each additional power supply module interrupts always 4 electrical signals.

If you need to interrupt less than 4 signals you can:

- assemble the valves to interrupt in the last positions of the manifold, so you don't need to worry about the interrupted exceeding signals;
- use a bistable base and mount a monostable valve (for each signal less than the 4 standard);
- use a monostable base and mount a closing plate (for each signal less than the 4 standard).

**EXAMPLE 3:**

Manifold of 7 monostable e 3 bistable valves on which you want to interrupt signals 2-3-4-5 and 8-9-10-11.

**Assembly:**

- 1 monostable valve (not interruptible because before the module),
- 1 additional power supply module,
- 6 monostable valves.

Please note: the first 4 monostable of these are interruptible by the module, while the following 2 will work correctly managed directly by the corresponding command signals.

- 1 additional power supply module,
- 3 bistable valves.

**Please note:** the first 2 bistable of these valves are interruptible by the module, while the following will work correctly managed directly by the corresponding command signals.

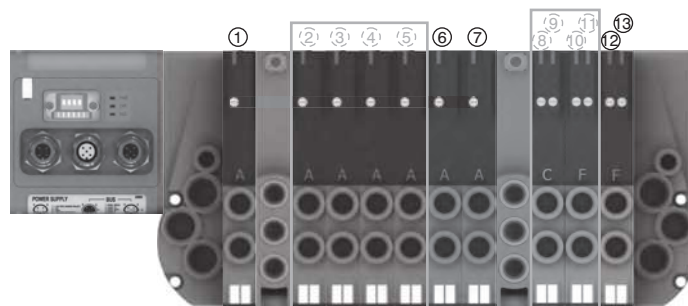



1  
AIR DISTRIBUTION

Polyethylene Silencer Series SPL-P

Coding: SPLP.ⓐ



TUBE DIAMETER	
ⓐ	18 = 1/8"
	14 = 1/4"
	38 = 3/8"

Diaphragm plug

Coding: 2530.17



Cable complete with connector, 25 Poles IP65

Coding: 2300.25.ⓐ.ⓐ



CABLE LENGTH	
ⓐ	03 = 3 meters
	05 = 5 meters
	10 = 10 meters
FUNCTION	
ⓑ	31 = Closed centres
	32 = Open centres
	33 = Pressured centres

Cable complete with connector, 37 Poles IP65

Coding: 2400.37.ⓐ.ⓐ



CABLE LENGTH	
ⓐ	03 = 3 meters
	05 = 5 meters
	10 = 10 meters
FUNCTION	
ⓑ	31 = Closed centres
	32 = Open centres
	33 = Pressured centres

Cable complete with connector, 25 Poles IP65

Coding: 2400.25.ⓐ.25



CABLE LENGTH	
ⓐ	03 = 3 meters
	05 = 5 meters
	10 = 10 meters



The electrical connection is achieved by a 37 pin connector and can manage up to 32 solenoid pilots.

It is also possible use a 25 sub-D pin connector and, in this case, it is possible to manage a maximum of 22 outputs. It is also available a terminal, able to manage a maximum of 16 outputs.

The management and distribution of the electrical signals between each valve is obtained thanks to an electrical connector which receives the signals from the previous module, uses one, two or none depending on the type, and carries forward to the next module the remaining.

Bistable valves, 5/3 and 2x3/2 valves which have two solenoid pilots built in, use two signals; the first is directed to the pilot side 14 the second to the pilot side 12. Modular bases can be fitted with two type of electrical connector: the monostable version uses only one signal (connected to the pilot side 14) and carries forward the remaining, the bistable version which always uses two signals.

This solution allows the modification of the manifold (replacement of monostable valves without bistable for example) without having to reset the PLC output layout.

On other hand this solution limits the maximum number of valves to 16 when it is used a 37 pin connector or 11 when it is used a 25 pin connector. When using a Endplates with terminal, the maximum number of valves are 8.

Intermediate supply/exhaust module uses an electrical connector directly forwarding signals to the next one without any kind of modification.

This allows the use of intermediate modules in any position of the manifold.

All the electrical signals that have not been used on the manifold can be used placing at the end of the manifold the end plate complete with the 25 sub-D female connector.

The number of available signals depends of the connector used to the type of the left end plate and by the total signals used along the manifold:

37 pin connector	nr of output = 32 – (total of used signals)
25 pin connector	nr of output = 22 – (total of used signals)
Terminal	nr of output = 16 – (total of used signals)

Following we show some examples of possible combination and the relative pin assignment.

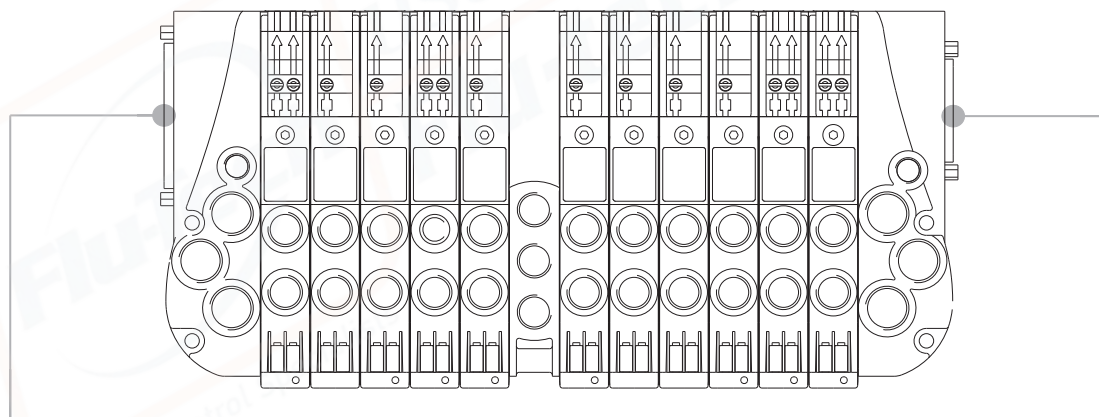

**IN-LET ELECTRIC CONNECTIONS**

**SUB-D 37 POLE MALE CONNECTOR**

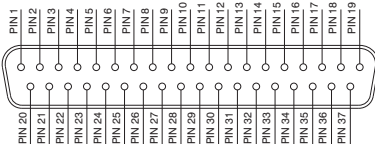

1 - 32 = Solenoid valves signals  
33 - 35 = GND  
36 - 37 = Through line

**SUB-D 25 POLE MALE CONNECTOR**

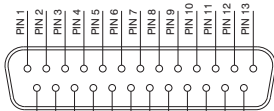

1 - 22 = Solenoid valves signals  
23 - 24 = GND  
25 = Through line

**TERMINAL 16 SIGNALS**

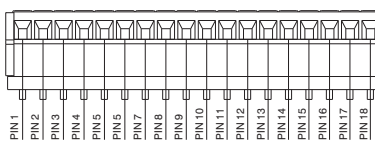

POS. 1-16 = SIGNALS  
POS. 17 = GND  
POS. 18 = THROUGH LINE

**OUTLET ELECTRIC CONNECTIONS (IF PRESENT)**

**SUB-D 25 POLE FEMALE CONNECTOR**

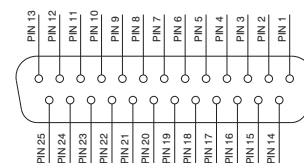

1 - 22 = Solenoid valves signals  
23 - 24 = GND  
25 = Through line

37 PIN Connector correspondence for valves assembled on mixed bases

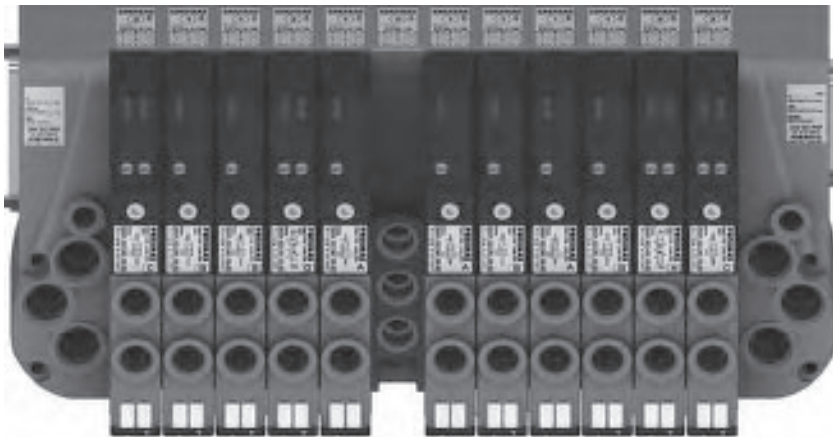

- PIN 1 = PILOT 14 SV POS.1
- PIN 2 = PILOT 12 SV POS.1
- PIN 3 = PILOT 14 SV POS.2
- PIN 4 = PILOT 14 SV POS.3
- PIN 5 = PILOT 14 SV POS.4
- PIN 6 = PILOT 12 SV POS.4
- PIN 7 = PILOT 14 SV POS.5
- PIN 8 = PILOT 14 SV POS.7
- PIN 9 = PILOT 14 SV POS.8
- PIN 10 = PILOT 14 SV POS.9
- PIN 11 = PILOT 14 SV POS.10
- PIN 12 = PILOT 14 SV POS.11
- PIN 13 = PILOT 12 SV POS.11
- PIN 14 = PILOT 14 SV POS.12
- PIN 15 = PILOT 12 SV POS.12

POS.	1	2	3	4	5	6	7	8	9	10	11	12
------	---	---	---	---	---	---	---	---	---	----	----	----

37 PIN Connector correspondence for manifold mounted on bases for bistable valves

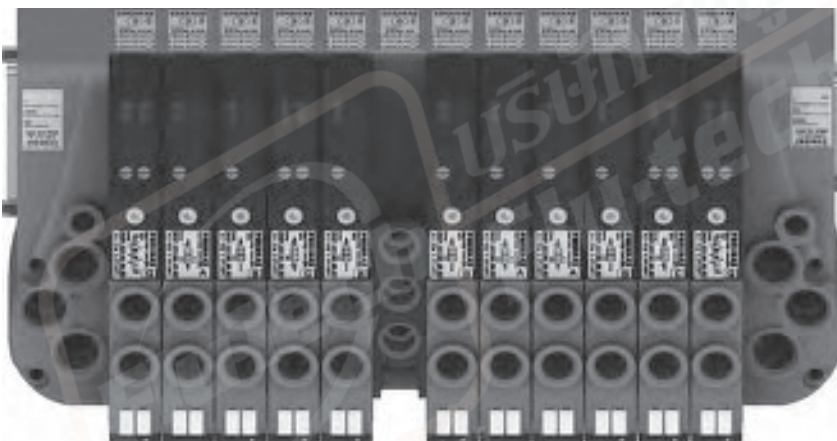

- PIN 1 = PILOT 14 SV POS.1
- PIN 2 = PILOT 12 SV POS.1
- PIN 3 = PILOT 14 SV POS.2
- PIN 4 = NOT CONNECTED
- PIN 5 = PILOT 14 SV POS.3
- PIN 6 = NOT CONNECTED
- PIN 7 = PILOT 14 SV POS.4
- PIN 8 = PILOT 12 SV POS.4
- PIN 9 = PILOT 14 SV POS.5
- PIN 10 = NOT CONNECTED
- PIN 11 = PILOT 14 SV POS.7
- PIN 12 = NOT CONNECTED
- PIN 13 = PILOT 14 SV POS.8
- PIN 14 = NOT CONNECTED
- PIN 15 = PILOT 14 SV POS.9
- PIN 16 = NOT CONNECTED
- PIN 17 = PILOT 14 SV POS.10
- PIN 18 = NOT CONNECTED
- PIN 19 = PILOT 14 SV POS.11
- PIN 20 = PILOT 12 SV POS.11
- PIN 21 = PILOT 14 SV POS.12
- PIN 22 = PILOT 12 SV POS.12

POS.	1	2	3	4	5	6	7	8	9	10	11	12
------	---	---	---	---	---	---	---	---	---	----	----	----

37 PIN Connector correspondence for manifold for 32 position manifold with monostable valves on base

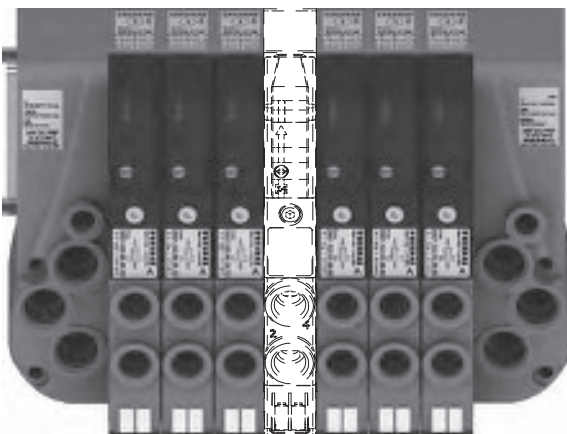

POS.	1	2	3	...	30	31	32
------	---	---	---	-----	----	----	----

25 PIN Connector correspondence for manifold for 22 position manifold with monostable valves on base

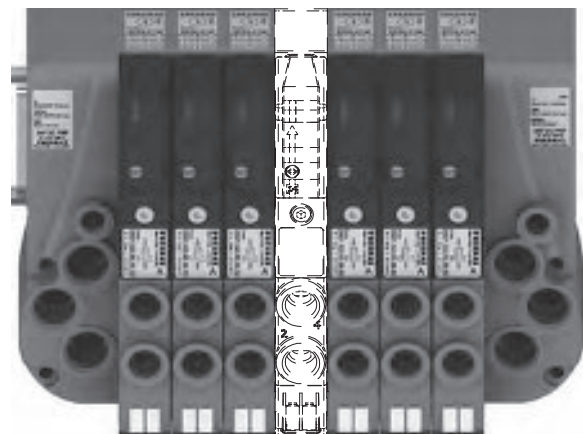

POS.	1	2	3	...	20	21	22
------	---	---	---	-----	----	----	----



**General :**

Using the 2530.03.25P output terminal it is possible to make any electrical signals not used by valves available on a 25 sub-D female connector at the right end of the manifold.  
It is possible to then join a multi-core cable to link to the next manifold, or connect directly to one or two I/O modules.  
The I/O modules can accept input or output signals, depending upon what is connected.

**Ordering code**

**2530.08F**

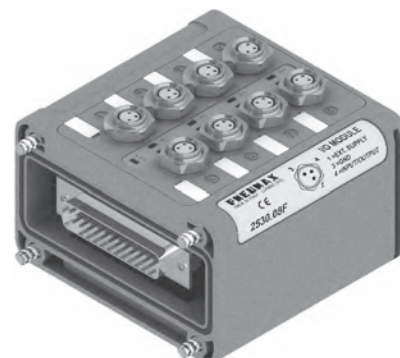

**Please note:** If the manifold is connected by a multi-core connection, each connection can be used as either an input or an output, while if the manifold is connected to a serial node the connections can only be used as an output.

It is possible to connect the manifold to up to two I/O modules.

Each I/O module includes 8 diagnostic LEDs which indicate the presence of an Input / Output signal for each connector.

**Please note:** For an LED to function, a signal of at least +15VDC must be present on pin 4 of the connector. If this signal is lower, the LED will not light, this does not compromise the normal Input / Output function of the unit.

**Overall dimensions and I/O layout :**

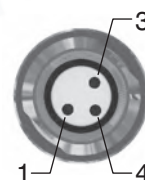
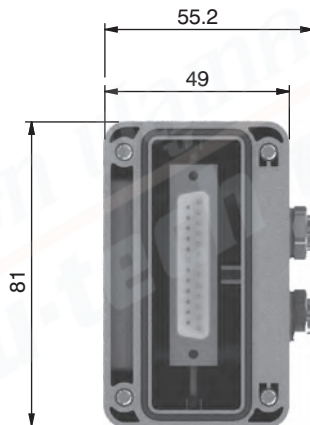
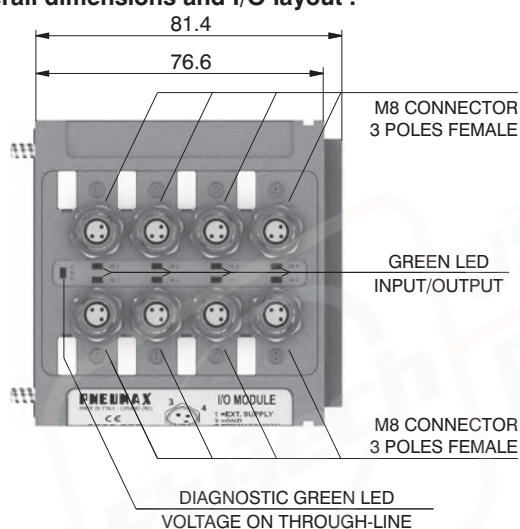

PIN	DESCRIPTION
1	+24 VDC
4	INPUT/OUTPUT
3	GND

**Input features:**

Each connection can accept either two wire (switches, magnetic switches, pressure switches, etc.) or three wire connections (photocells, electronic end of stroke sensors, etc.) If +24VDC is required on at Pin 1 of each connector, it is possible to provide this via the through-line pin of the multi-pole connector.

I.E :

Pin 25 of the 25 pin multi-pole connector (code 2530.02.25P or 2530.12.25P)

Pin 36-37 of the 37 pin multi-pole connector (code 2530.02.37P or 2530.12.37P)

**Output features:**



**Attention:** The output connections are not protected against short-circuit. Please pay attention when wiring (avoid Pin 4 being connected to Pin 3 or Pin 1).

<b>General characteristics</b>	Model	2530.08F
	Case	Reinforced technopolymer
	I/O Connector	M8 connector 3 poles female (IEC 60947-5-2)
	PIN1 voltage (connector used as Input)	By the user
	PIN 4 voltage diagnosis	Green LED
	Node consumption (Outlets excluded)	7mA per each LED with 24 VDC signal
	Outlets voltage	+23,3 VDC (serial) /by the user (multipolar)
	Input voltage	Depend by the using
	Maximum outlet current	100 mA (serial) / 400 mA (multipolar)
	Maximum Input/Output	8 per module
	Multiconnector max. Current	100 mA
	Connections to manifold	Direct connection to 25 poles connector
	Maximum n. of moduls	2
	Protection degree	IP65 when assembled
Ambient temperature	from -0° to +50° C	

1  
AIR DISTRIBUTION

**CORRESPONDENCE BETWEEN MULTI-POLE SIGNAL AND CONNECTOR**

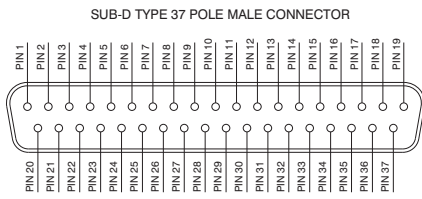

1 - 32 = SIGNALS  
 33 - 35 = GND  
 36 - 37 = THROUGH LINE

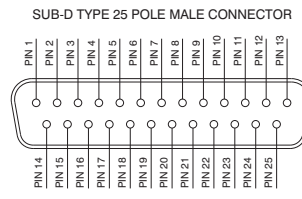

1 - 22 = SIGNALS  
 23 - 24 = GND  
 25 = THROUGH LINE

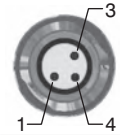

PIN DESCRIPTION	
1	THROUGH LINE
4	SIGNAL
3	GND

**Connection modes:**

The I/O module changes its operation depending on the way the manifold is controlled. There are two possible modes:

- A) Control via multi-pole connection
- B) Control via fieldbus

**A) Control via multi-pole :**

*M8 connector used as Input:*



**Attention:** Voltage applied to each connector is passed to multi-pole connector pin.

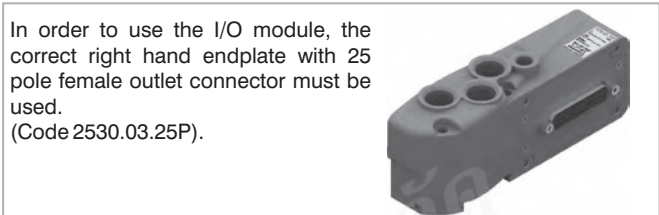

In order to use the I/O module, the correct right hand endplate with 25 pole female outlet connector must be used.  
 (Code 2530.03.25P).

*M8 connector used as Output:*

Output voltage will be the same as is applied at the multi-pole connector pin.  
 The maximum output current depends upon the power unit used, but we recommend no more than 250mA.

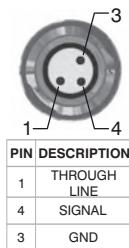

PIN DESCRIPTION	
1	THROUGH LINE
4	SIGNAL
3	GND



**Attention:** Since every cable has a degree of resistance, there will always be a voltage drop depending on the cable's length, sectional area and the current.

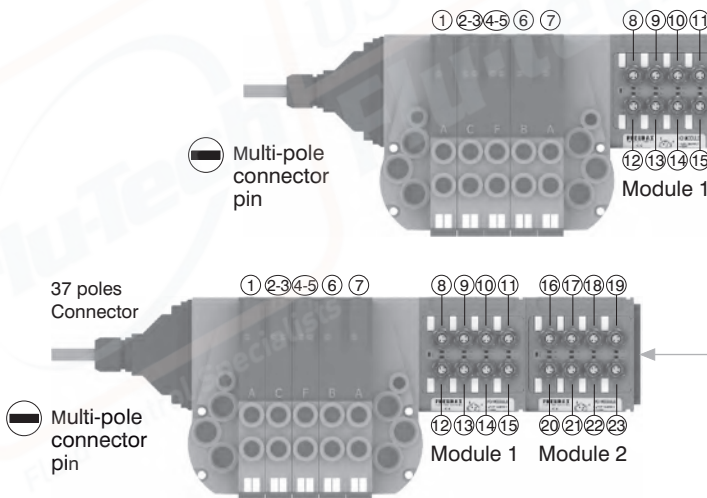

**Attention:** Only one more I/O module can be added.

**Attention:** No more additions are possible

**Attention :** Optyma 32-F solenoid valve manifolds permit up to 22 electrical signals that are not used by manifolds to be made available: these signals can be managed by another manifold and / or by I/O modules.  
 The I/O module will manage these unused signals. Connections that are not managing useful signals will remain unconnected.

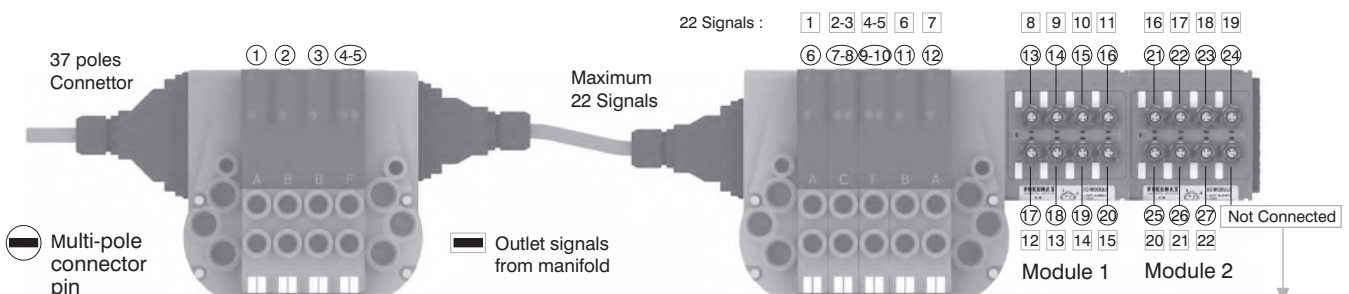

**Please note:** this example considers a 37 pin multi-pole connector.  
 The same configuration managed by a 25 pin multi-pole connector will stop at number 22 of multi-pole connector and at number 17 of the manifold. 22 17

**Attention:** Signal Not connected  
 GND Connected  
 Through line Connected

1 AIR DISTRIBUTION



**Please note:** Optyma 32-F solenoid valve manifolds manage up to 32 signals. If the manifold uses more than 24 signals the I/O module will manage only the remainder. Connections that are not managing useful signals will remain unconnected.

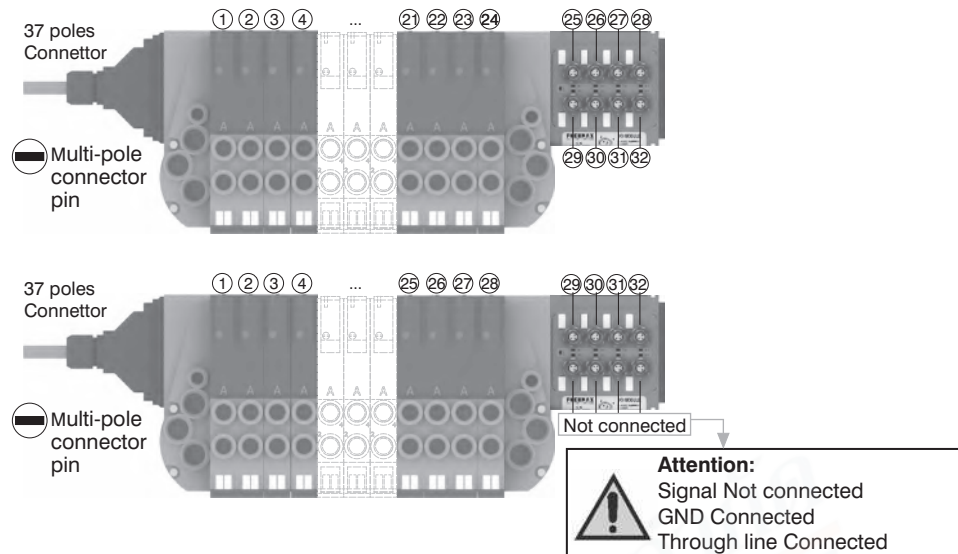

**B) Control via fieldbus:**

With this kind of control the I/O module can only be used as an output. Pin 1 of each connector is not connected. The output voltage will be 0.7V lower than that applied to Pin 4 of the connector. The maximum output current for each output is 100mA. The correspondence between control byte and each single output depends on how many electrical signals are used by the manifold and by the relative position of the I/O module.

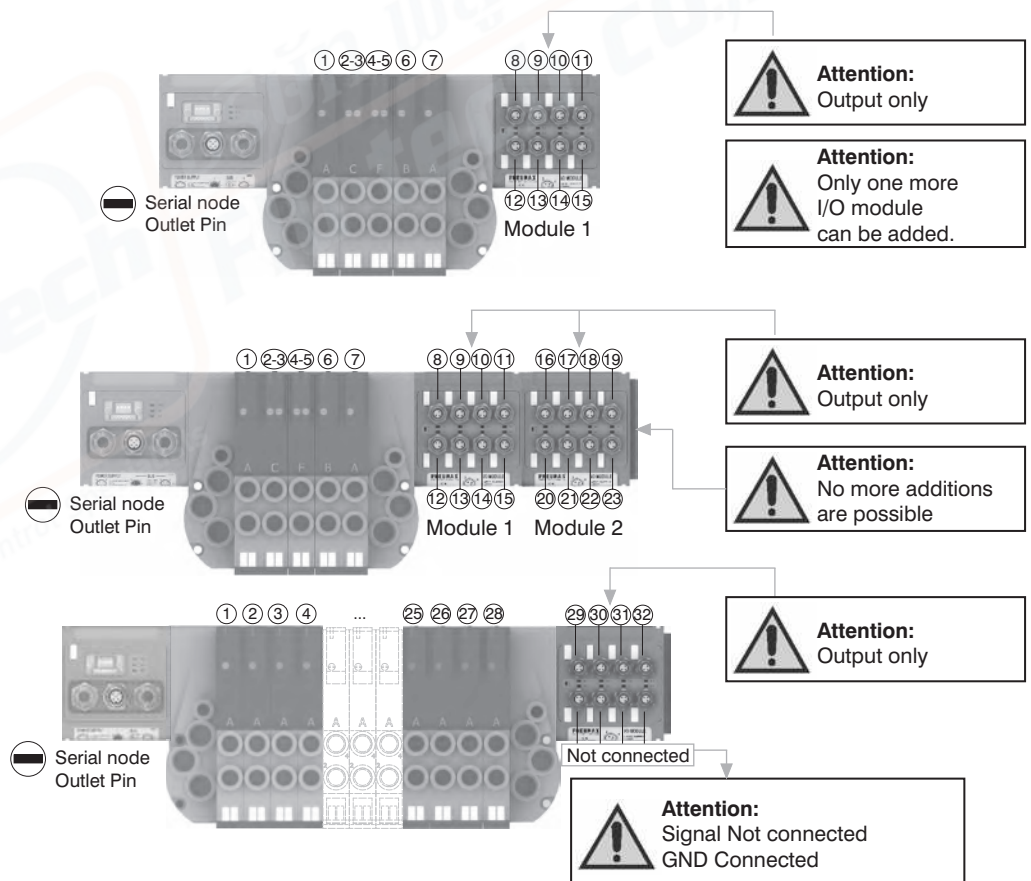
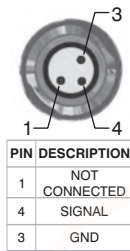

**Please note:** I/O modules don't allow to connect any additional valves manifold after them.

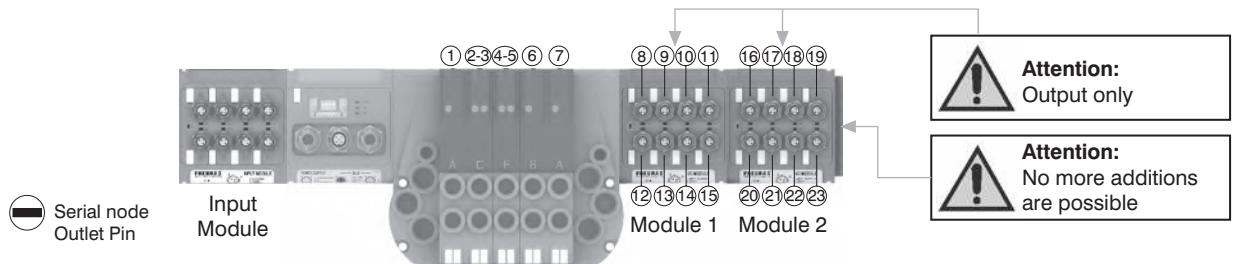

From the top

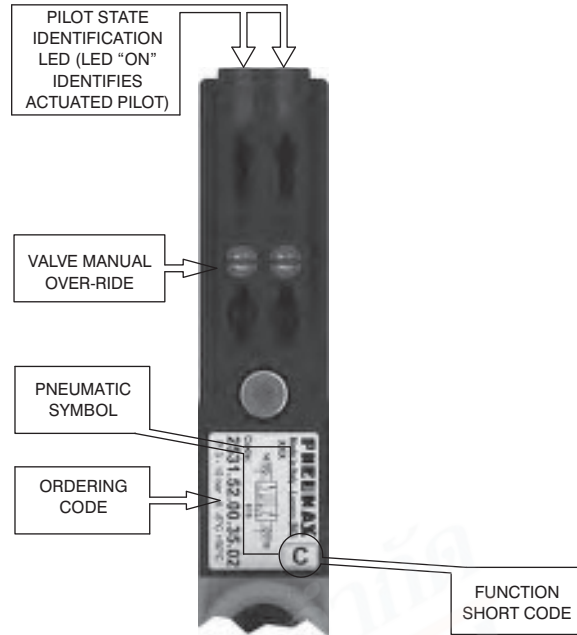
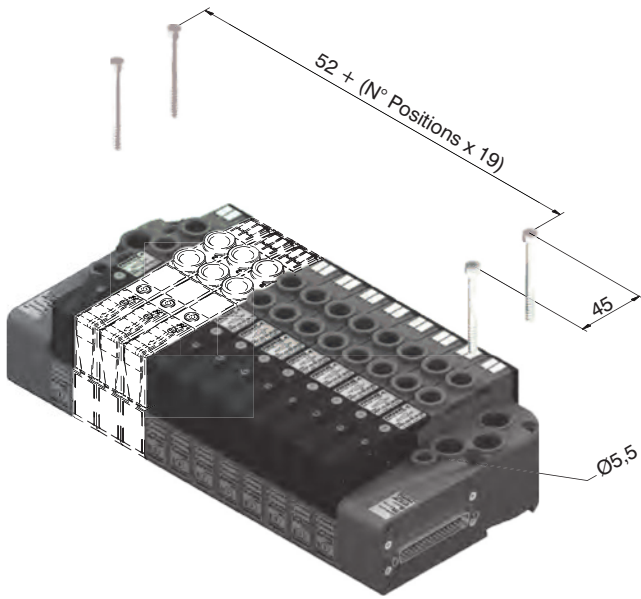

DIN rail fixing

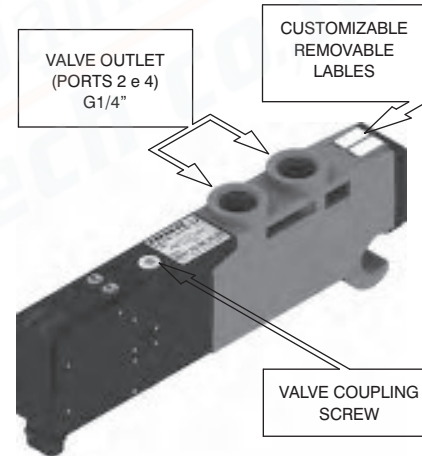
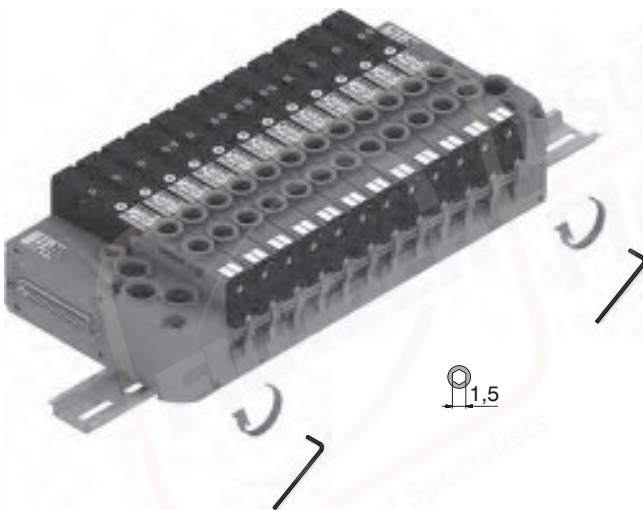

Maximum possible size according to valves seats

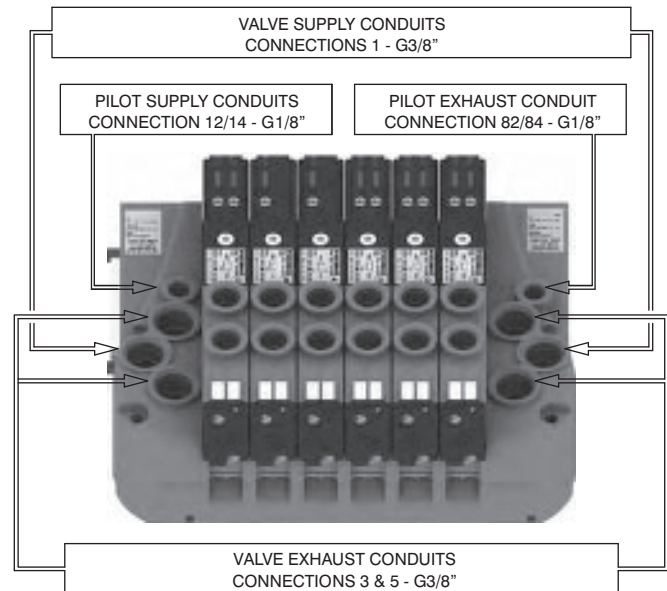
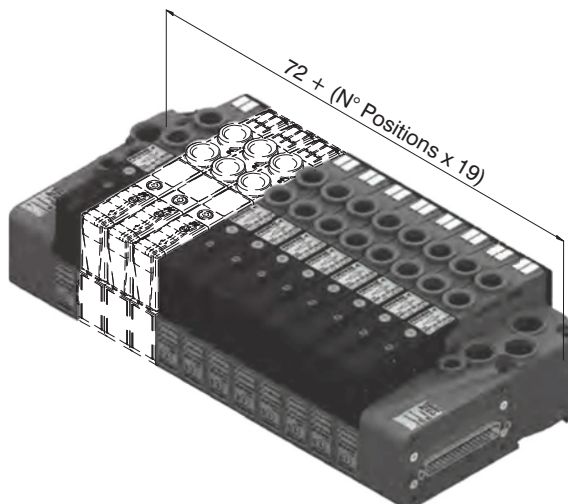

Manual override actuation

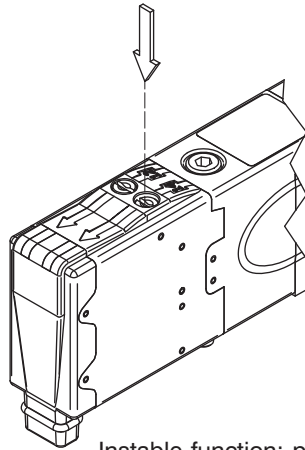
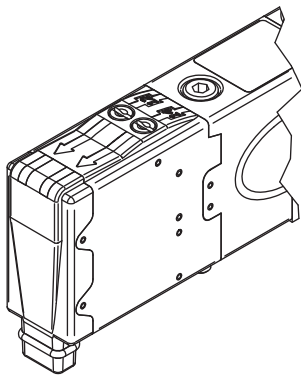

Instable function: push to actuate  
(when released it moves back to  
the original position).

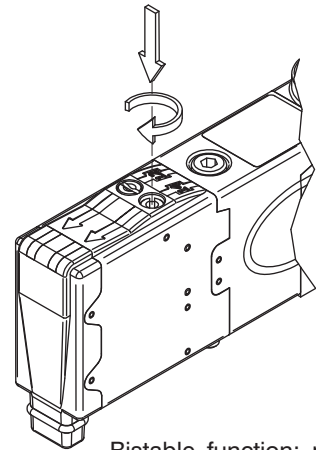

Bistable function: push and  
turn to get the bistable  
function

NOTE : It is strongly suggested to replace the original position after using

Valve Installation

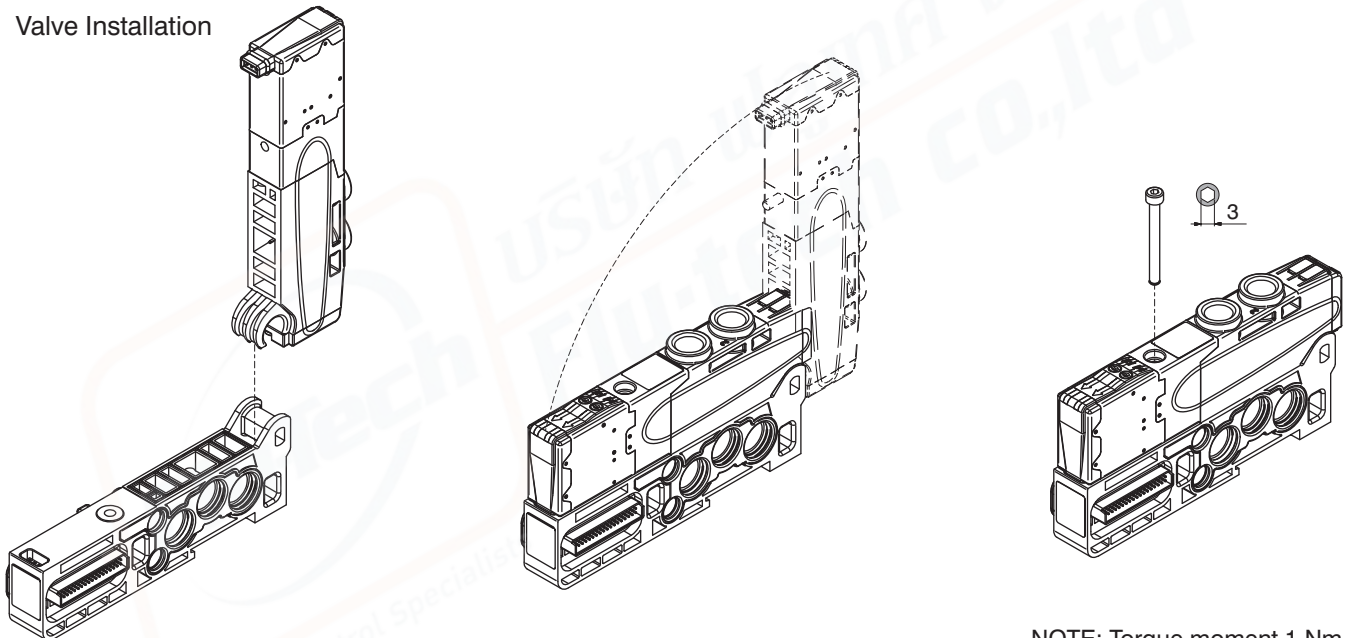

NOTE: Torque moment 1 Nm

Manifold assembly

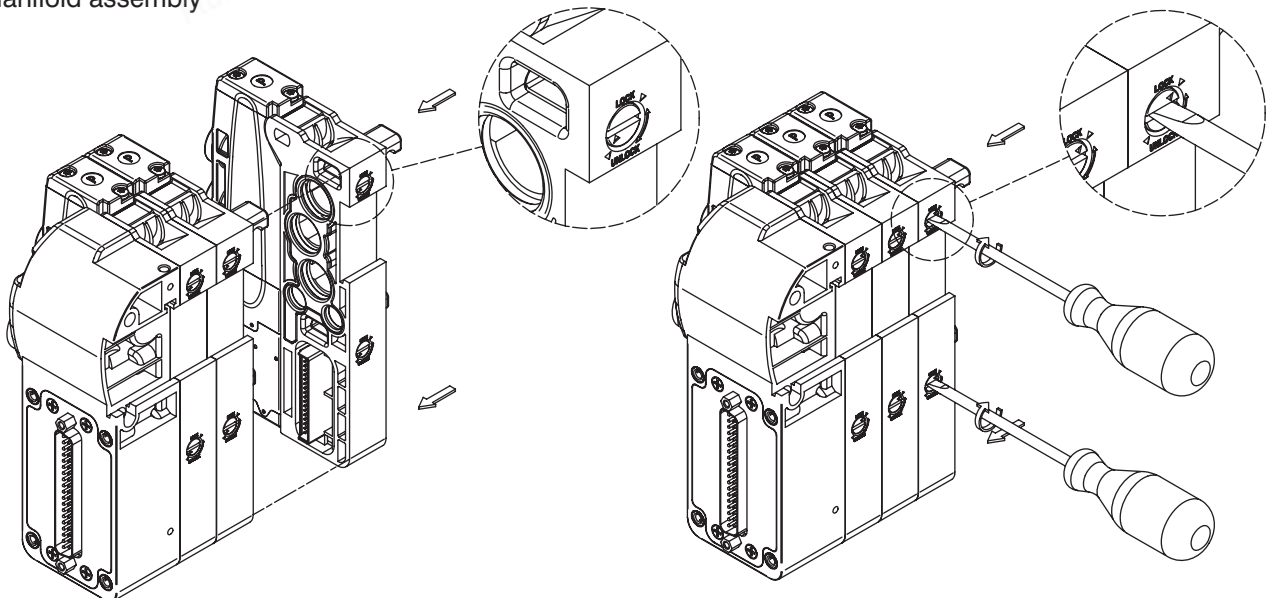

Manifold Layout configuration

1  
AIR DISTRIBUTION

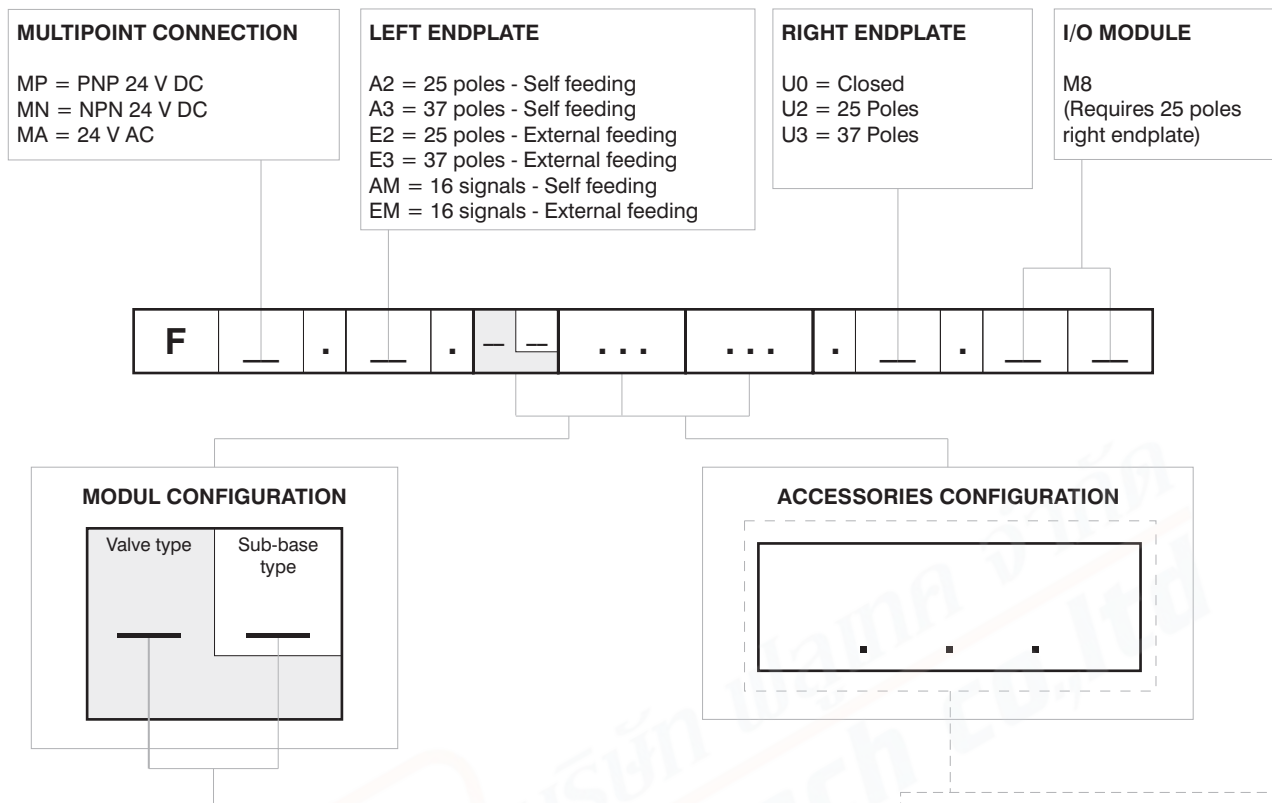

**SHORT CODE FUNCTION / CONNECTION :**

A1= 5/2 SOL.-SPRING + BASE TYPE 1 (1 electrical signal occupied)  
A2= 5/2 SOL.-SPRING + BASE TYPE 2 (2 electrical signals occupied)  
B1= 5/2 SOL.-DIFFERENTIAL + BASE TYPE 1 (1 electrical signal occupied)  
B2= 5/2 SOL.-DIFFERENTIAL + BASE TYPE 2 (2 electrical signals occupied)  
C2= 5/2 SOL.-SOL. + BASE TYPE 2 (2 electrical signals occupied)  
E2= 5/3 CC SOL.-SOL. + BASE TYPE 2 (2 electrical signals occupied)  
F2= 2x3/2 NC-NC (= 5/3 OC) SOL.-SOL.+BASE TYPE 2 (2 electrical signals occupied)  
G2= 2x3/2 NO-NO (= 5/3 PC) SOL.-SOL.+BASE TYPE 2 (2 electrical signals occupied)  
H2= 2x3/2 NC-NO SOL.-SOL. + BASE TYPE 2 (2 electrical signals occupied)  
I2= 2x3/2 NO-NC SOL.-SOL. + BASE TYPE 2 (2 electrical signals occupied)  
T1= FREE VALVE SPACE PLUG + BASE FOR MONOSTABLE VALVE  
T2= FREE VALVE SPACE PLUG + BASE FOR BISTABLE VALVE

**ACCESSORIES**

U2 = Power supply 2 positions module  
U4 = Power supply 4 positions module  
W = Intermediate supply & exhaust module  
X = Diaphragm plug on pipe 1  
Y = Diaphragm plug on pipe 3  
Z = Diaphragm plug on pipe 5  
XY = Diaphragm plug on pipe 1 & 3  
ZX = Diaphragm plug on pipe 5 & 1  
ZY = Diaphragm plug on pipe 5 & 3  
ZXY = Diaphragm plug on pipe 5, 1 & 3

**NOTE:**  
While configuring the manifold always be careful that the maximum number of electrical signals available is:  
32 when an input 37 poles endplate is used.  
22 when an input 25 poles endplate is used.  
The use of monostable valve mounted on a base type 2 ( 2 electrical signals occupied ) causes the loss of one electric signal.  
In this case the monostable valve can be replaced by a bistable valve. The diaphragms plugs are used to intercept the conduits 1,3 & 5 of the base. If it is necessary to interrupt more than one conduit in the same time then put in line the letters which identifies the position (for example : regarding the 3 & 5 conduits, put the Y & Z letters).  
Should one or more conduits be cut more than one time it is necessary to add the relevant intermediate Supply/Exhaust module.

Series 2500 OPTYMA-F solenoid valve manifolds managed by multipoint connection are "well tried components"

	<b>Well-tryed component</b>	- The product is a well-tryed product for a safety-related application according to ISO 13849-1. - The relevant basic and well-tryed safety principles according ISO 13849-2 for this product are fulfilled.
<b>B<sub>10d</sub></b>	50.000.000	- The suitability of the product for a precise application must be verified and confirmed by the user.



**General:**

CANopen® module is directly integrated on Optyima-F solenoid valves manifold via a 37 poles connector, normally used for multipolar cable connection.  
Optyima-F solenoid valves connected to node must be PNP equivalent (final 02 in ordering code).

The node can be easily installed also on solenoid valves manifold already mounted on equipment.

Module can manage up to 32 solenoid valves, and, in the same time, a max number of 4 Input modules 5225.08F or a max number of 2 Input modules 5225.25F.

CANopen® module recognizes automatically the presence of the Input modules on power on. Regardless of the number of Input modules connected, the manageable solenoid valves are 32.

Node power supply is made by a M12 4P male circular connector.

The separation between node 24 VDC Power supply and outputs 24 VDC allows to switch off the outputs maintaining powered the node and inputs, if present.

Connection to Bus CANopen® is possible via 2 M12 5P male - female circular connectors; these two are connected in parallel and according to CiA Draft Recommendation 303-1 (V. 1.3 : 30 December 2004).

Transmission speed can be set by 3 dip-switches.

The node address can be set by 6 dip-switches using BCD numeration.

The module includes an internal terminating resistance that can be activated by a dip-switch.

**Ordering code**

**5525.32F**



1  
AIR DISTRIBUTION

**Scheme / Overall dimensions and I/O layout :**

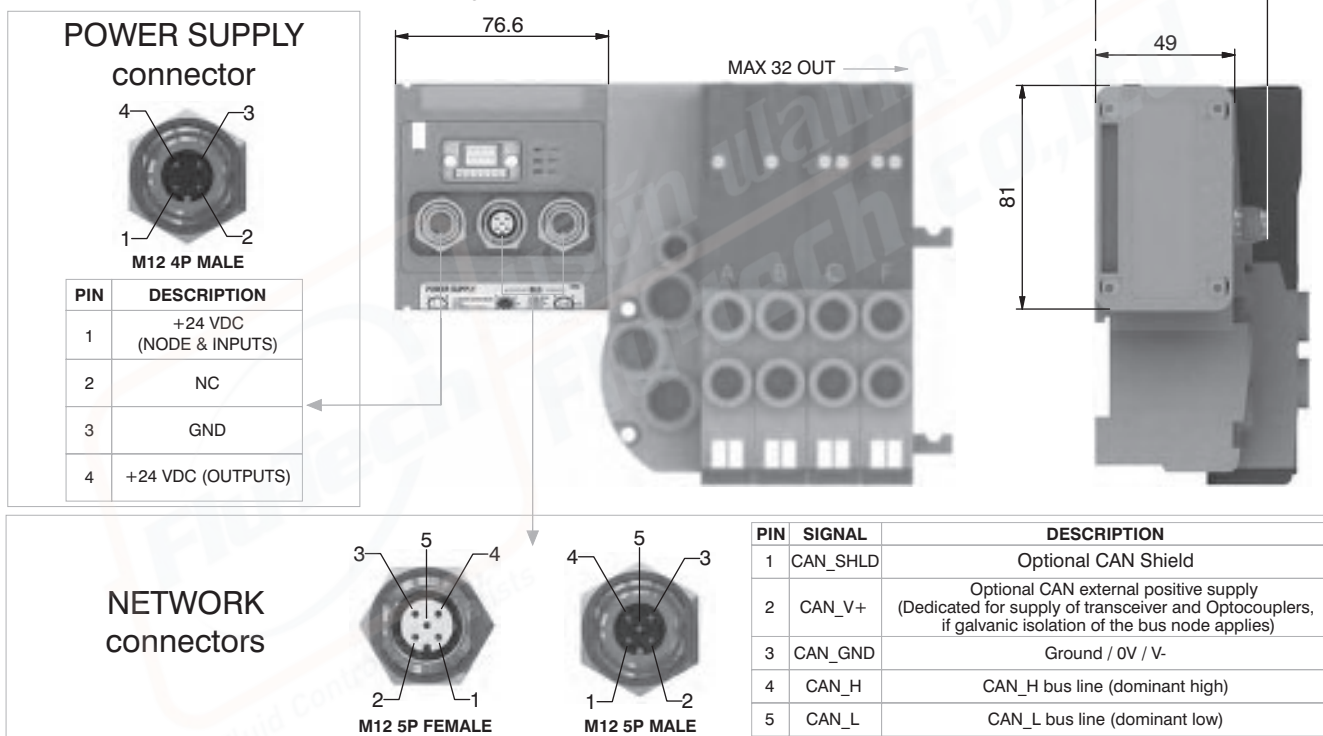

**Technical characteristics**

	Model	5525.32F
	Specifications	CiA Draft Standard Proposal 301 V 4.10 (15 August 2006)
	Case	Reinforced technopolymer
<b>Power supply</b>	Power supply connection	M12 4P male connector (IEC 60947-5-2)
	Power supply voltage	+24 VDC +/- 10%
	Node consumption (without inputs)	30 mA
	Power supply diagnosis	Green LED PWR
<b>Outputs</b>	PNP equivalent outputs	+24 VDC +/- 10%
	Maximum current for output	100 mA
	Maximum output number	32
	Max output simultaneously actuated	32
<b>Network</b>	Network connectors	2 M12 5P connectors male-female type A (IEC 60947-5-2)
	Baud rate	10 - 20 - 50 - 125 - 250 - 500 - 800 - 1000 Kbit/s
	Addresses, possible numbers	From 1 to 63
	Max nodes in net	64 (slave + master)
	Bus maximum recommended length	100 m at 500 Kbit/s
	Bus diagnosis	Green LED + Red LED
	Configuration file	Available from our web site: <a href="http://www.pneumaxspa.com">http://www.pneumaxspa.com</a>
	IP protection grade	IP65 when assembled
	Temperature range	From 0° to +50° C

**General:**

DeviceNet module is directly integrated on Optyima-F solenoid valves manifold via a 37 poles connector, normally used for multipolar cable connection. Optyima-F solenoid valves connected to node must be PNP equivalent (final 02 in ordering code).

The node can be easily installed also on solenoid valves manifold already mounted on equipment.

Module can manage up to 32 solenoid valves, and, in the same time, a max number of 4 Input modules 5225.08F or a max number of 2 Input modules 5225.25F.

DeviceNet module recognizes automatically the presence of the Input modules on power on.

Regardless of the number of Input modules connected, the managable solenoid valves are 32.

Node power supply is made by a M12 4P male circular connector.

The separation between node 24 VDC Power supply and outputs 24 VDC allows to switch off the outputs maintaining powered the node and inputs, if present.

Connection to Bus DeviceNet is possible via 2 M12 5P male - female circular connectors; these two are connected in parallel and according to DeviceNet Specifications Volume I, release 2.0.

Transmission speed can be set by 3 dip-switches.

The node address can be set by 6 dip-switches using BCD numeration.

The module includes an internal terminating resistance that can be activated by a dip-switch.

**Ordering code**

**5425.32F**



1  
AIR DISTRIBUTION

**Scheme / Overall dimensions and I/O layout :**

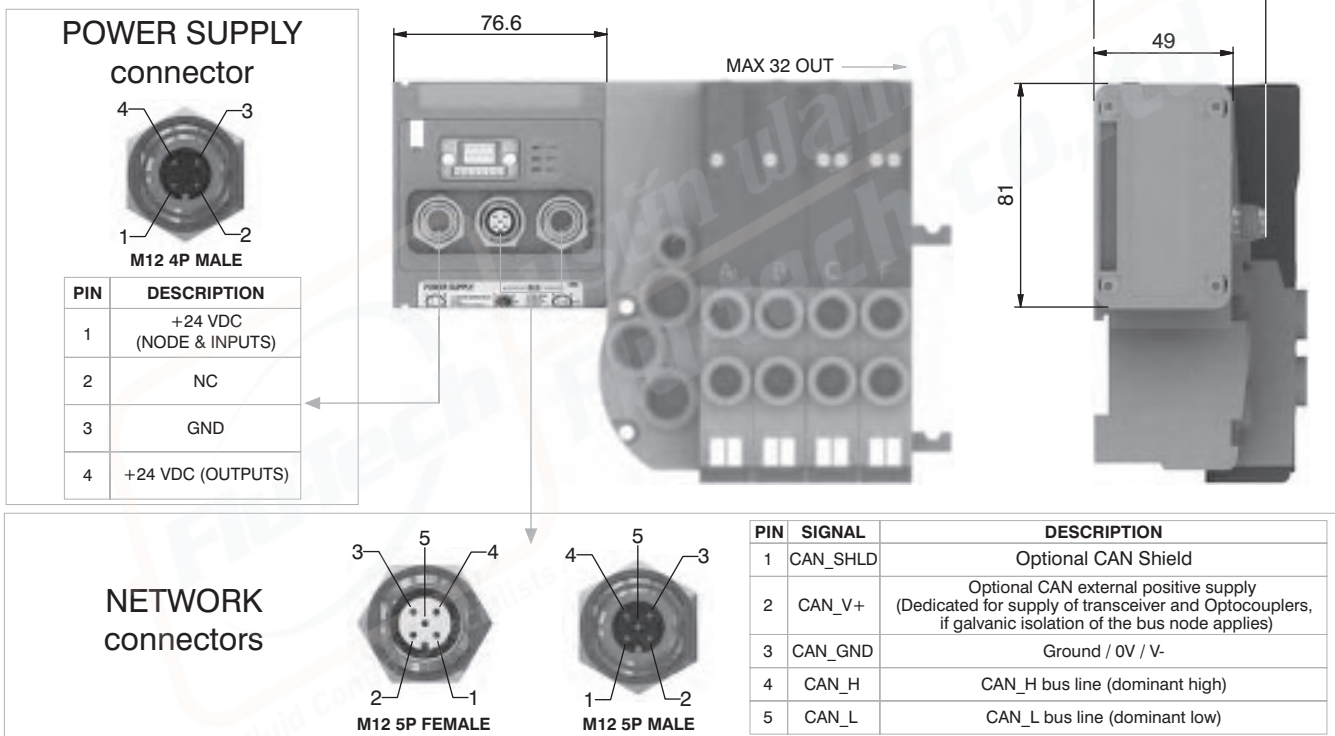

**Technical characteristics**

	Model	5425.32F
	Specifications	DeviceNet Specifications Volume I, release 2.0.
	Case	Reinforced technopolymer
<b>Power supply</b>	Power supply connection	M12 4P male connector (IEC 60947-5-2)
	Power supply voltage	+24 VDC +/- 10%
	Node consumption (without inputs)	30 mA
	Power supply diagnosis	Green LED PWR
<b>Outputs</b>	PNP equivalent outputs	+24 VDC +/- 10%
	Maximum current for output	100 mA
	Maximum output number	32
	Max output simultaneously actuated	32
<b>Network</b>	Network connectors	2 M12 5P connectors male-female type A (IEC 60947-5-2)
	Baud rate	125 - 250 - 500 Kbit/s
	Addresses, possible numbers	From 1 to 63
	Max nodes in net	64 (slave + master)
	Bus maximum recommended length	100 m at 500 Kbit/s
	Bus diagnosis	Green LED + Red LED
	Configuration file	Available from our web site: <a href="http://www.pneumaxspa.com">http://www.pneumaxspa.com</a>
	IP protection grade	IP65 when assembled
	Temperature range	From 0° to +50° C



**General:**

PROFIBUS DP module is directly integrated on Optyma-F solenoid valves manifold via a 37 poles connector, normally used for multipolar cable connection.

Optyma-F solenoid valves connected to node must be PNP equivalent (final 02 in ordering code). The node can be easily installed also on solenoid valves manifold already mounted on equipment.

Module can manage up to 32 solenoid valves, and, in the same time, a max number of 4 Input modules 5225.08F or a max number of 4 Input modules 5225.25F.

PROFIBUS DP module recognizes automatically the presence of the Input modules on power on. Regardless of the number of Input modules connected, the manageable solenoid valves are 32.

Node power supply is made by a M12 4P male circular connector.

The separation between node 24 VDC Power supply and outputs 24 VDC allows to switch off the outputs maintaining powered the node and inputs, if present.

Connection to Bus PROFIBUS DP is possible via 2 M12 type B 5P male - female circular connectors; these two are connected in parallel and according to PROFIBUS Interconnection Technology (Version 1.1 : August 2001).

The node address can be set using BCD numeration: 4 dip-switches for the units and 4 dip-switches for the tens.

The module includes an internal terminating resistance that can be activated by 2 dip-switches.

**Ordering code**

**5325.32F**



1  
AIR DISTRIBUTION

**Scheme / Overall dimensions and I/O layout :**

**POWER SUPPLY connector**

**M12 4P MALE**

PIN	DESCRIPTION
1	+24 VDC (NODE & INPUTS)
2	NC
3	GND
4	+24 VDC (OUTPUTS)

PIN	SIGNAL	DESCRIPTION
1	VP	Power supply plus, (P5V)
2	A-line	Receive / Transmit data -N, A-line
3	DGND	Data Ground (reference potential to VP)
4	B-line	Receive / Transmit data +plus, B-line
5	SHIELD	Shield or PE

**Technical characteristics**

	Model	5325.32F
	Specifications	PROFIBUS DP
	Case	Reinforced technopolymer
<b>Power supply</b>	Power supply connection	M12 4P male connector (IEC 60947-5-2)
	Power supply voltage	+24 VDC +/- 10%
	Node consumption (without inputs)	50 mA
	Power supply diagnosis	Green LED PWR / Green LED OUT
<b>Outputs</b>	PNP equivalent outputs	+24 VDC +/- 10%
	Maximum current for output	100 mA
	Maximum output number	32
	Max output simultaneously actuated	32
<b>Network</b>	Network connectors	2 M12 5P male-female connectors type B
	Baud rate	9,6 - 19,2 - 93,75 - 187,5 - 500 - 1500 - 3000 - 6000 - 12000 Kbit/s
	Addresses, possible numbers	From 1 to 99
	Max nodes in net	100 (slave + master)
	Bus maximum recommended length	100 m at 12 Mbit/s - 1200 m at 9,6 Kbit/s
	Bus diagnosis	Green LED + Red LED
	Configuration file	Available from our web site: <a href="http://www.pneumaxspa.com">http://www.pneumaxspa.com</a>
	IP protection grade	IP65 when assembled
	Temperature range	From 0° to +50° C

**General:**

EtherCAT® module is directly integrated on Optyma-F solenoid valves manifold via a 37 poles connector, normally used for multipolar cable connection.

Optyma-F solenoid valves connected to node must be PNP equivalent (final 02 in ordering code). The node can be easily installed also on solenoid valves manifold already mounted on equipment.

Module can manage up to 32 solenoid valves, and, in the same time, a max number of 4 Input modules 5225.08F or a max number of 2 Input modules 5225.25F.

The EtherCAT® module, regardless the number of Input module connected, reports to have connected 4 Input modules.

Regardless of the number of Input modules connected, the manageable solenoid valves are 32.

Node power supply is made by a M12 4P male circular connector.

The separation between node 24 VDC Power supply and outputs 24 VDC allows to switch off the outputs maintaining powered the node and inputs, if present.

Connection to Bus EtherCAT® is possible via 2 M12 4P type D female circular connectors. These two connectors lead the signal to two different communication ports, so they are not connected in parallel.

The node address is assigned during configuration.

**Note: 5700 series has a different configuration file from series 5600.**

**Ordering code**

**5725.32F.EC**



**Scheme / Overall dimensions and I/O layout :**

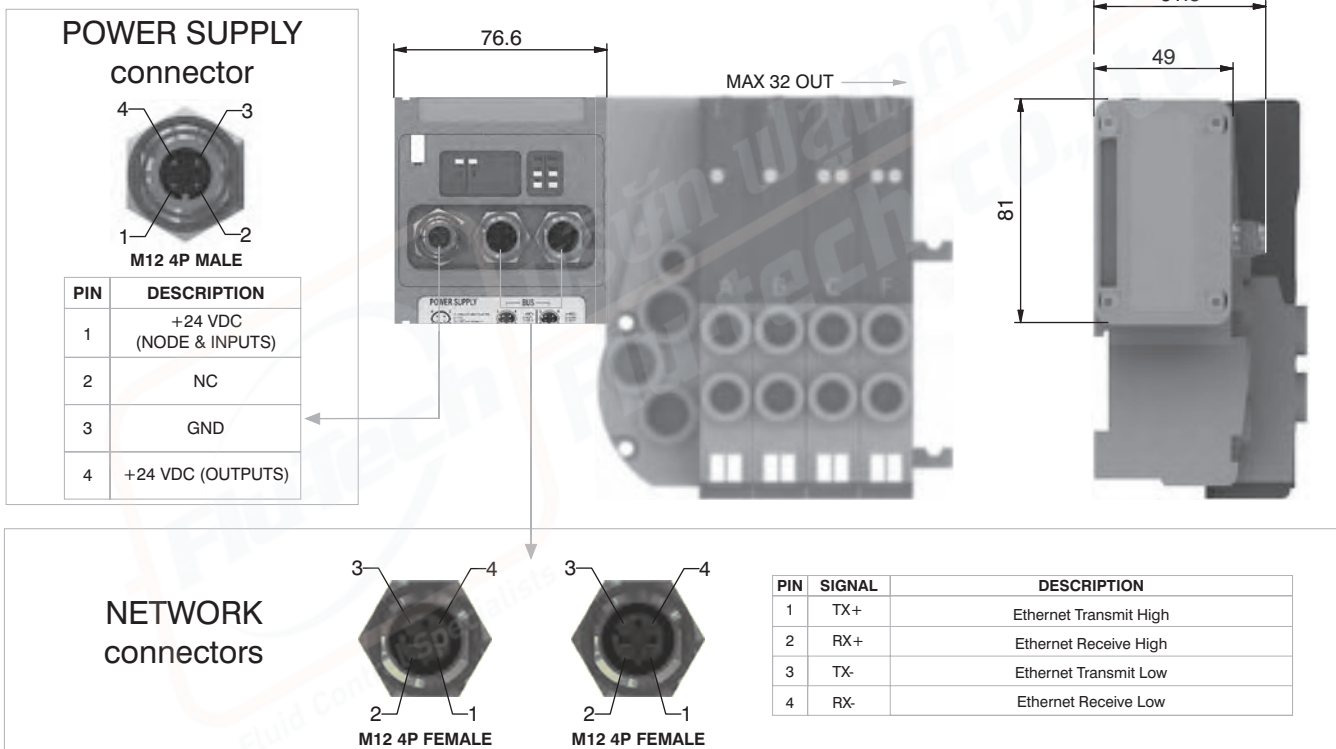

**Technical characteristics**

	Model	5725.32F.EC
	Specifications	EtherCAT® Specifications ETG.1000 series
	Case	Reinforced technopolymer
<b>Power supply</b>	Power supply connection	M12 4P male connector (IEC 60947-5-2)
	Power supply voltage	+24 VDC +/- 10%
	Node consumption (without inputs)	400 mA
	Power supply diagnosis	Green LED PWR / Green LED OUT
<b>Outputs</b>	PNP equivalent outputs	+24 VDC +/- 10%
	Maximum current for output	100 mA
	Maximum output number	32
	Max output simultaneously actuated	32
<b>Network</b>	Network connectors	2 M12 4P female connectors type D (IEC 61076-2-101)
	Baud rate	100 Mbit/s
	Addresses, possible numbers	From 1 to 65535
	Max nodes in net	65536 (slave + master)
	Maximum distance between 2 nodes	100 m
	Bus diagnosis	1 green and 1 red LED for status + 2 LEDs for link & activity
	Configuration file	Available from our web site: <a href="http://www.pneumaxspa.com">http://www.pneumaxspa.com</a>
	IP protection grade	IP65 when assembled
	Temperature range	From 0° to +50° C

**General:**

PROFINET IO RT module is directly integrated on Optyma-F solenoid valves manifold via a 37 poles connector, normally used for multipolar cable connection. Optyma-F solenoid valves connected to node must be PNP equivalent (final 02 in ordering code).

The node can be easily installed also on solenoid valves manifold already mounted on equipment.

Module can manage up to 32 solenoid valves, and, in the same time, a max number of 4 Input modules 5225.08F or a max number of 4 Input modules 5225.25F.

The PROFINET IO RT module, regardless the number of Input module connected, reports to have connected 8 Input modules.

Regardless of the number of Input modules connected, the manageable solenoid valves are 32.

Node power supply is made by a M12 4P male circular connector.

The separation between node 24 VDC Power supply and outputs 24 VDC allows to switch off the outputs maintaining powered the node and inputs, if present.

Connection to Bus PROFINET IO RT is possible via 2 M12 4P type D female circular connectors. These two connectors lead the signal to two different communication ports, so they are not connected in parallel.

The node address is assigned during configuration.

**Ordering code**

**5725.32F.PN**



1  
AIR DISTRIBUTION

**Scheme / Overall dimensions and I/O layout :**

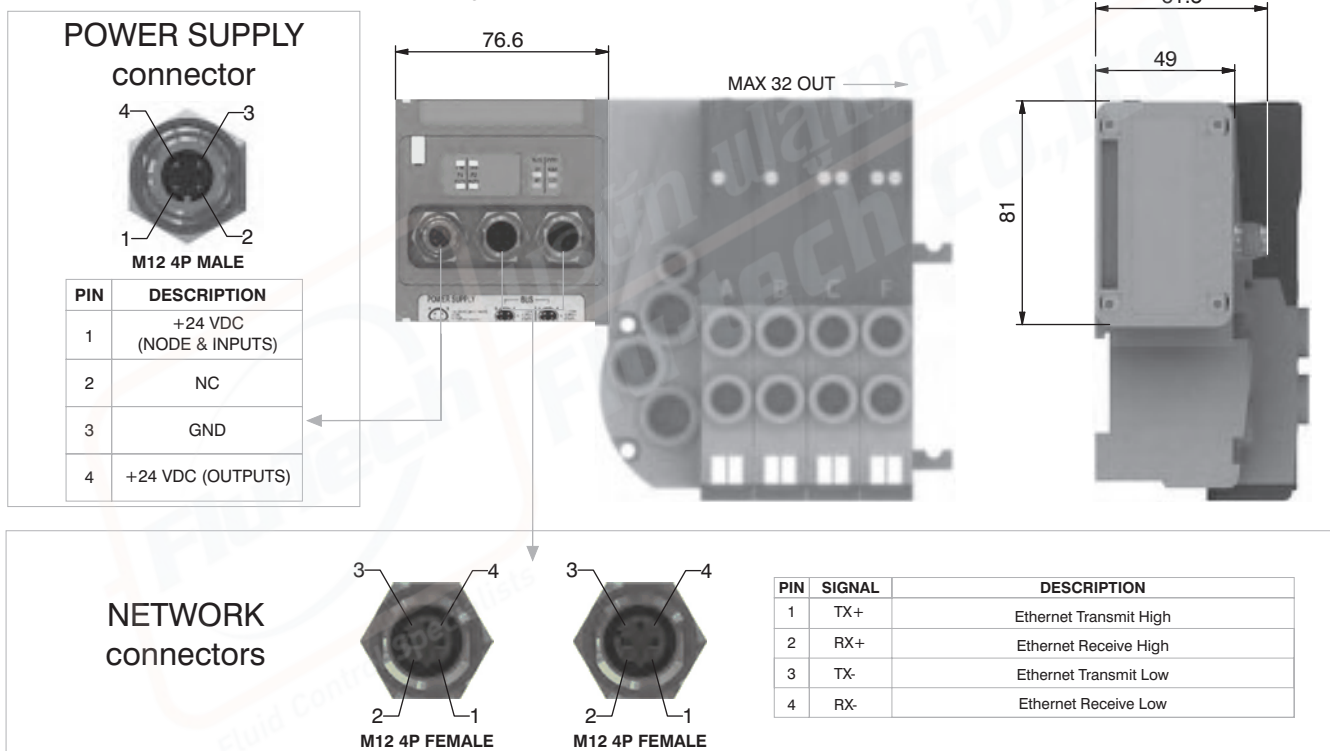

**Technical characteristics**

	Model	5725.32F.PN
	Specifications	PROFINET IO RT
	Case	Reinforced technopolymer
<b>Power supply</b>	Power supply connection	M12 4P male connector (IEC 60947-5-2)
	Power supply voltage	+24 VDC +/- 10%
	Node consumption (without inputs)	400 mA
	Power supply diagnosis	Green LED PWR / Green LED OUT
<b>Outputs</b>	PNP equivalent outputs	+24 VDC +/- 10%
	Maximum current for output	100 mA
	Maximum output number	32
	Max output simultaneously actuated	32
<b>Network</b>	Network connectors	2 M12 4P female connectors type D (IEC 61076-2-101)
	Baud rate	100 Mbit/s
	Addresses, possible numbers	As an IP address
	Max nodes in net	As an Ethernet Network
	Maximum distance between 2 nodes	100 m
	Bus diagnosis	1 green and 1 red LED for status + 4 LEDs for link & activity
	Configuration file	Available from our web site: <a href="http://www.pneumaxspa.com">http://www.pneumaxspa.com</a>
	IP protection grade	IP65 when assembled
	Temperature range	From 0° to +50° C

**General:**

EtherNet/IP module is directly integrated on Optyma-F solenoid valves manifold via a 37 poles connector, normally used for multipolar cable connection. Optyma-F solenoid valves connected to node must be PNP equivalent (final 02 in ordering code).

The node can be easily installed also on solenoid valves manifold already mounted on equipment.

Module can manage up to 32 solenoid valves, and, in the same time, a max number of 4 Input modules 5225.08F or a max number of 4 Input modules 5225.25F.

The EtherNet/IP module, regardless the number of Input module connected, reports to have connected 8 Input modules.

Regardless of the number of Input modules connected, the managable solenoid valves are 32.

Node power supply is made by a M12 4P male circular connector.

The separation between node 24 VDC Power supply and outputs 24 VDC allows to switch off the outputs maintaining powered the node and inputs, if present.

Connection to Bus EtherNet/IP is possible via 2 M12 4P type D female circular connectors. These two connectors lead the signal to two different communication ports, so they are not connected in parallel.

The node address is assigned during configuration.

**Ordering code**

**5725.32F.EI**



**Scheme / Overall dimensions and I/O layout :**

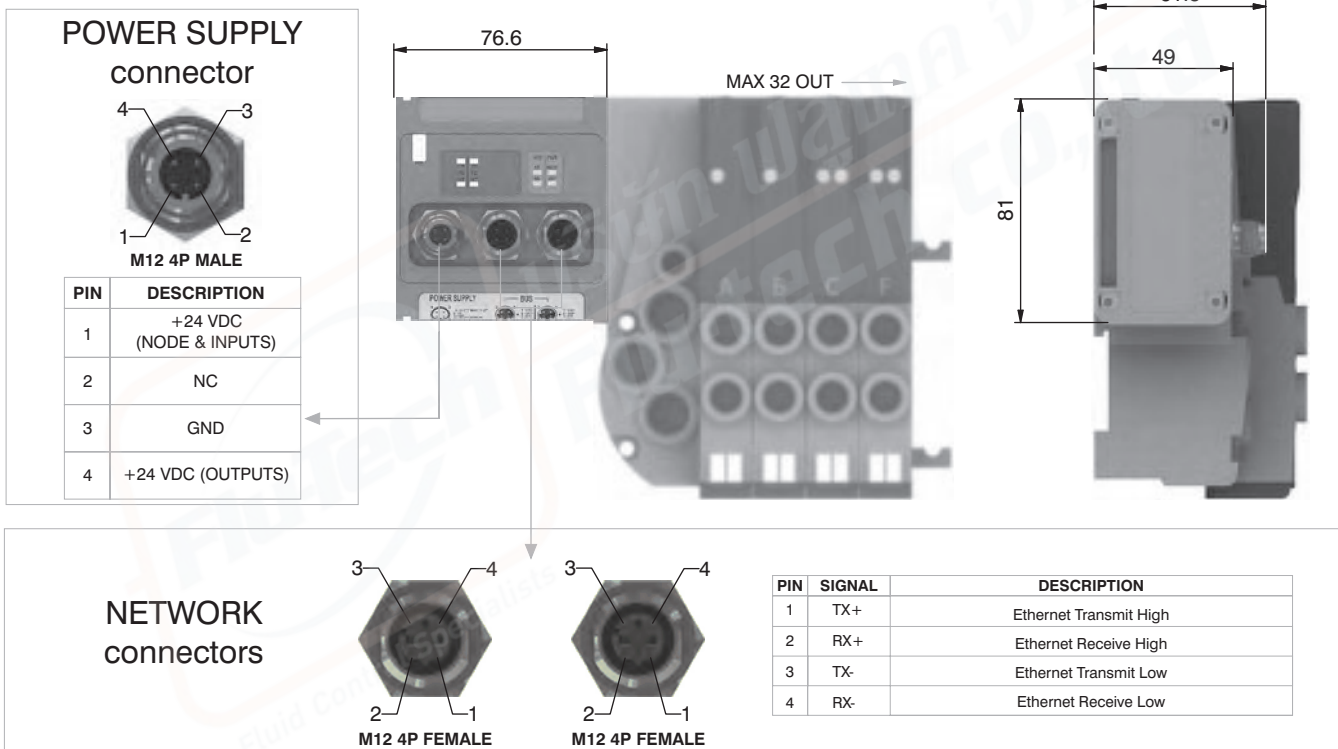

**Technical characteristics**

	Model	5725.32F.EI
	Specifications	The EtherNet/IP Specification
	Case	Reinforced technopolymer
<b>Power supply</b>	Power supply connection	M12 4P male connector (IEC 60947-5-2)
	Power supply voltage	+24 VDC +/- 10%
	Node consumption (without inputs)	400 mA
	Power supply diagnosis	Green LED PWR / Green LED OUT
<b>Outputs</b>	PNP equivalent outputs	+24 VDC +/- 10%
	Maximum current for output	100 mA
	Maximum output number	32
	Max output simultaneously actuated	32
<b>Network</b>	Network connectors	2 M12 4P female connectors type D (IEC 61076-2-101)
	Baud rate	100 Mbit/s
	Addresses, possible numbers	As an IP address
	Max nodes in net	As an Ethernet Network
	Maximum distance between 2 nodes	100 m
	Bus diagnosis	1 green and 1 red LED for status + 4 LEDs for link & activity
	Configuration file	Available from our web site: <a href="http://www.pneumaxspa.com">http://www.pneumaxspa.com</a>
	IP protection grade	IP65 when assembled
	Temperature range	From 0° to +50° C

**General:**

Powerlink module is directly integrated on Optyima-F solenoid valves manifold via a 37 poles connector, normally used for multipolar cable connection.  
Optyima-F solenoid valves connected to node must be PNP equivalent (final 02 in ordering code).

The node can be easily installed also on solenoid valves manifold already mounted on equipment.

Module can manage up to 32 solenoid valves, and, in the same time, a max number of 4 Input modules 5225.08F or a max number of 4 Input modules 5225.25F.

The Powerlink module, regardless the number of Input module connected, reports to have connected 8 Input modules.

Regardless of the number of Input modules connected, the manageable solenoid valves are 32.

Node power supply is made by a M12 4P male circular connector.

The separation between node 24 VDC Power supply and outputs 24 VDC allows to switch off the outputs maintaining powered the node and inputs, if present.

Connection to Bus Powerlink is possible via 2 M12 4P type D female circular connectors. These two connectors lead the signal to two different communication ports, so they are not connected in parallel.

The node address is assigned during configuration.

**Ordering code**

**5725.32F.PL**



**Scheme / Overall dimensions and I/O layout :**

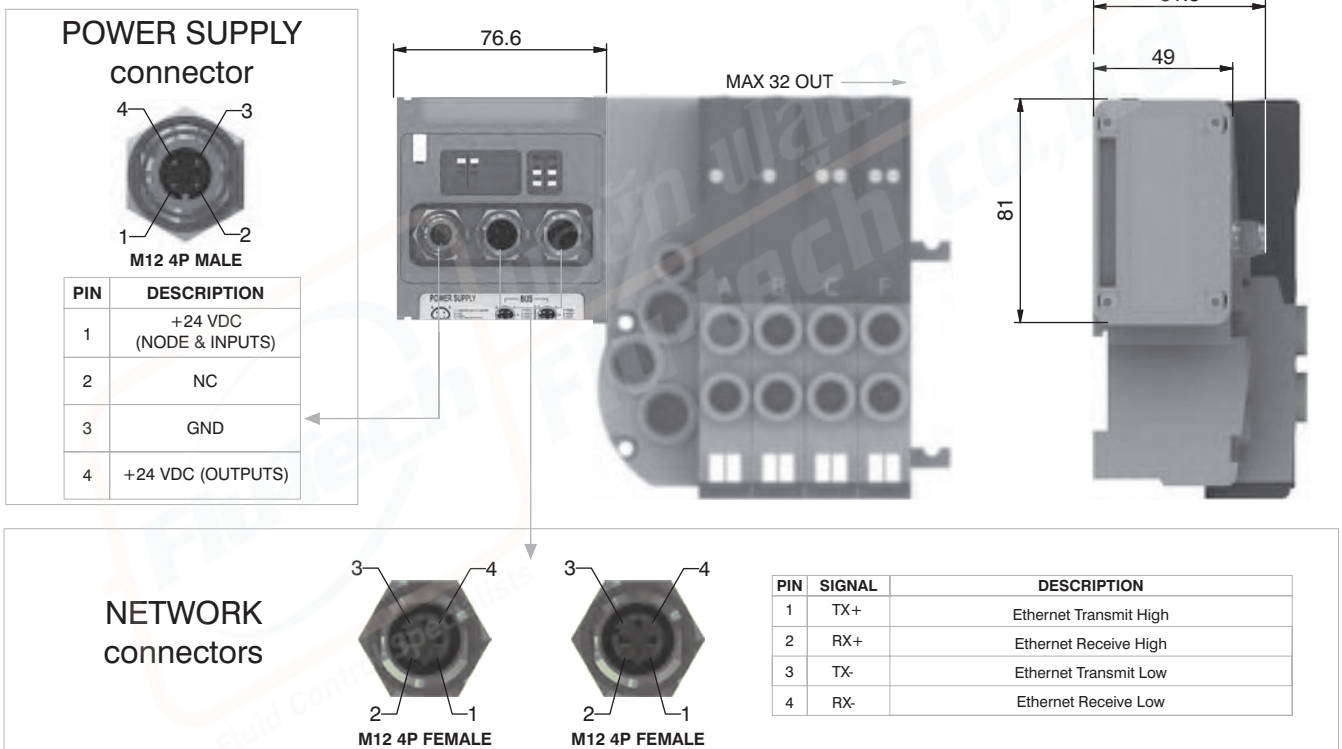

**Technical characteristics**

	Model	5725.32F.PL
	Specifications	Ethernet POWERLINK Communication Profile Specifications
	Case	Reinforced technopolymer
<b>Power supply</b>	Power supply connection	M12 4P male connector (IEC 60947-5-2)
	Power supply voltage	+24 VDC +/- 10%
	Node consumption (without inputs)	400 mA
	Power supply diagnosis	Green LED PWR / Green LED OUT
<b>Outputs</b>	PNP equivalent outputs	+24 VDC +/- 10%
	Maximum current for output	100 mA
	Maximum output number	32
	Max output simultaneously actuated	32
<b>Network</b>	Network connectors	2 M12 4P female connectors type D (IEC 61076-2-101)
	Baud rate	100 Mbit/s
	Addresses, possible numbers	239
	Max nodes in net	240
	Maximum distance between 2 nodes	100 m
	Bus diagnosis	1 green and 1 red LED for status + 2 LEDs for link & activity
	Configuration file	Available from our web site: <a href="http://www.pneumaxspa.com">http://www.pneumaxspa.com</a>
	IP protection grade	IP65 when assembled
	Temperature range	From 0° to +50° C

1  
AIR DISTRIBUTION

**General:**

Modbus/TCP module is directly integrated on Optyma-F solenoid valves manifold via a 37 poles connector, normally used for multipolar cable connection.  
 Optyma-F solenoid valves connected to node must be PNP equivalent (final 02 in ordering code).

The node can be easily installed also on solenoid valves manifold already mounted on equipment.

Module can manage up to 32 solenoid valves, and, in the same time, a max number of 4 Input modules 5225.08F or a max number of 4 Input modules 5225.25F.

The Modbus/TCP module, regardless the number of Input module connected, reports to have connected 8 Input modules.

Regardless of the number of Input modules connected, the managable solenoid valves are 32.

Node power supply is made by a M12 4P male circular connector.

The separation between node 24 VDC Power supply and outputs 24 VDC allows to switch off the outputs maintaining powered the node and inputs, if present.

Connection to Bus Modbus/TCP is possible via 2 M12 4P type D female circular connectors. These two connectors lead the signal to two different communication ports, so they are not connected in parallel.

The node address is assigned during configuration.

**Ordering code**

**5725.32F.MT**



**Scheme / Overall dimensions and I/O layout :**

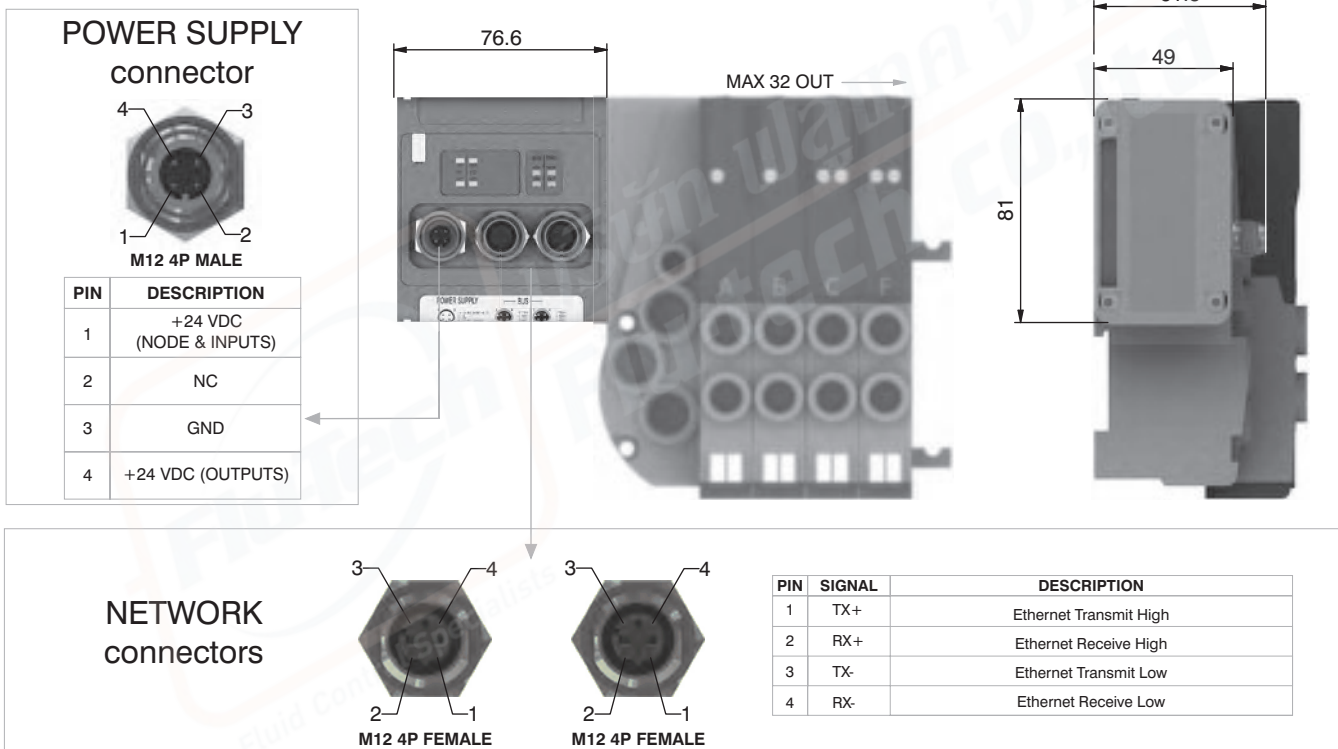

**Technical characteristics**

Model	5725.32F.MT
Specifications	MODBUS Application Protocol Specification V1.1a, June 4, 2004
Case	Reinforced technopolymer
<b>Power supply</b>	Power supply connection: M12 4P male connector (IEC 60947-5-2)
	Power supply voltage: +24 VDC +/- 10%
	Node consumption (without inputs): 400 mA
	Power supply diagnosis: Green LED PWR / Green LED OUT
<b>Outputs</b>	PNP equivalent outputs: +24 VDC +/- 10%
	Maximum current for output: 100 mA
	Maximum output number: 32
	Max output simultaneously actuated: 32
<b>Network</b>	Network connectors: 2 M12 4P female connectors type D (IEC 61076-2-101)
	Baud rate: 100 Mbit/s
	Addresses, possible numbers: 248
	Max nodes in net: 248
	Maximum distance between 2 nodes: 100 m
	Bus diagnosis: 1 green and 1 red LED for status + 2 LEDs for link & activity
	Configuration file: Modbus/TCP nodes don't require configuration file
	IP protection grade: IP65 when assembled
	Temperature range: From 0° to +50° C



**General:**

Modules have 8 connectors M8 3P female.

The Inputs are PNP equivalent 24 VDC ± 10%.

To each connector it is possible to plug both 2 wires Inputs (switches, magnetic switches pressure switches, etc.) or 3 wires Inputs (proximity, photocells, electronic sensors, etc).

The maximum current available for all 8 Inputs is 200 mA.

Each module includes a 200 mA self-mending fuse. If a short circuit or a overcharge (overall current >200mA) occur the safety device acts cutting the 24 VDC power supply to all M8 connectors on the module and switching off the green LED PWR. Any other Input module connected to the node will remain powered and will function correctly.

Once the cause of the fault disappears the green LED PWR lights up indicating the ON state and the node will re-start to operate.

The maximum number of Input modules supported is 4.

**Ordering code**

**5225.08F**



**Scheme / Overall dimensions and I/O layout :**

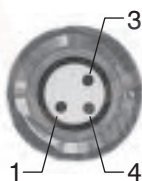
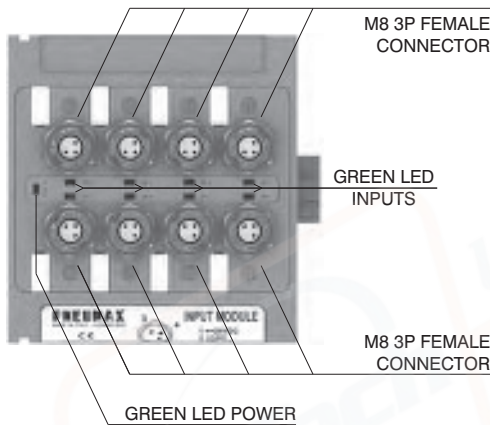

PIN	DESCRIPTION
1	+24 VDC
4	INPUT
3	GND

Module 1

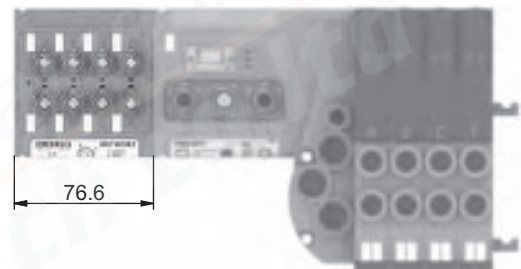

Module 2    Module 1

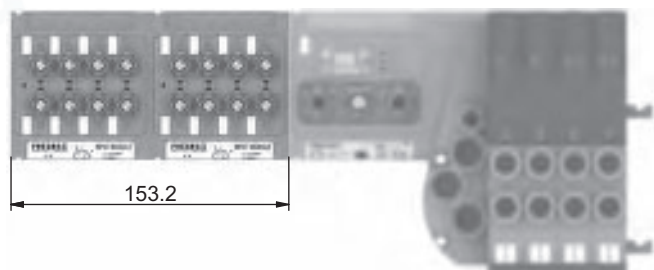

Module 3    Module 2    Module 1

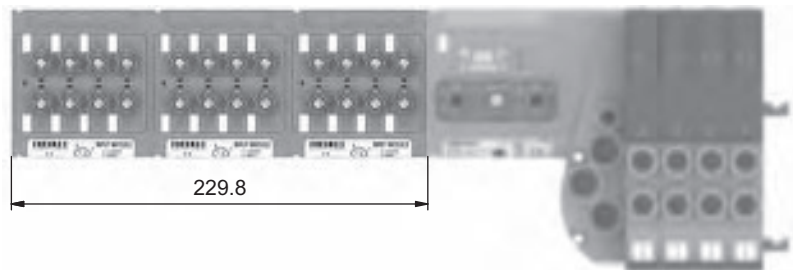

Module 4    Module 3    Module 2    Module 1

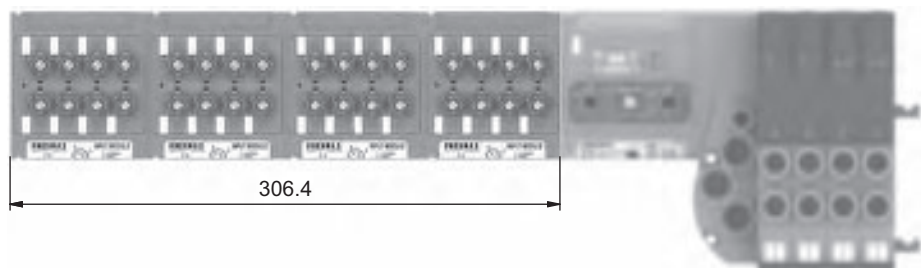

1  
AIR DISTRIBUTION

**General :**

Modules are fitted with SUB-D 25 pin female connector.

The Inputs are PNP equivalent 24VDC  $\pm$  10%.

To the connector it is possible to connect both 2 wires Inputs (switches, magnetic switches pressure switches etc.) or 3 wires (proximity, photocells, electronic end of stroke sensors etc).

The maximum current available for all 16 Inputs is 750 mA.

Each module includes a 750 mA self-mending fuse. Should a short circuit or a overcharge (overall current >750mA) occur the safety device intervenes cutting the 24VDC power supply to all pins and switching off the green LED PWR. Any other Input module connected to the node will remain powered and will function correctly.

Once the cause of the fault is removed the green LED lights up indicating the ON state and the node will re-start to operate. This 16 Inputs module is counted as two 8 Inputs modules.

The Maximum number of 16 Inputs modules supported is 2 for CANopen®, DeviceNet and EtherCAT®.

The Maximum number of 16 Inputs modules supported is 4 for PROFIBUS DP, PROFINET IO RT, EtherNet/IP and Powerlink.

**Ordering code**

**5225.25F**



**Scheme / Overall dimensions and I/O layout :**

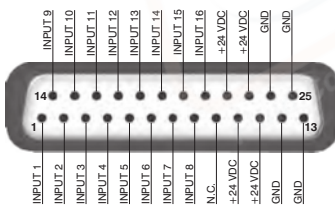
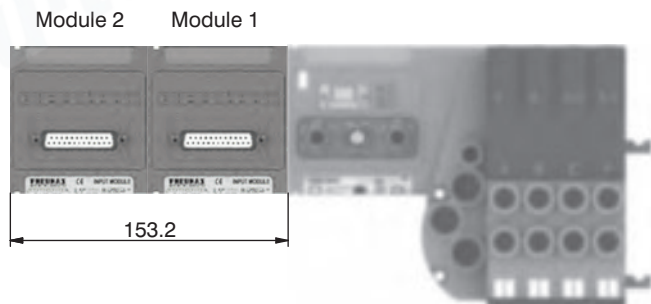
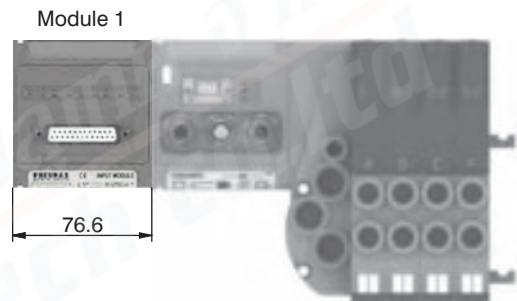
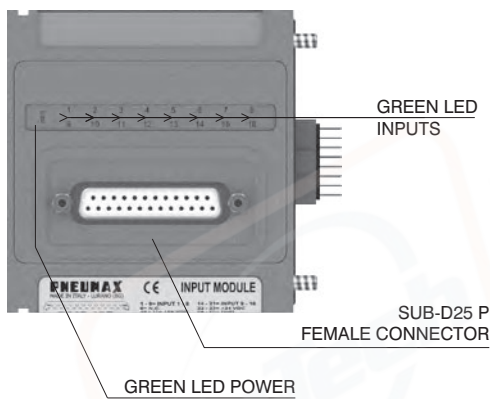



**General :**

This module is fitted with two M8 3 pin female connectors.

With this module is possible to read two analogue inputs (voltage or current).

The inputs are sampled at 12 bit.

For practicality the sampled value is transmitted with 16 bit, of which the four less significant are fixed at zero.

Available models:

- 5225.2T.00F (voltage signal 0 - 10V);
- 5225.2T.01F (voltage signal 0 - 5V);
- 5225.2C.00F (current signal 4 - 20mA);
- 5225.2C.01F (current signal 0 - 20mA).

Each module includes a 300 mA self-mending fuse. Should a short circuit or a overcharge (overall current >300mA) occur the safety device intervenes cutting the 24VDC power supply to all M8 connectors on the module and switching off the green LED PWR. Any other Input module connected to the node will remain powered and will function correctly.

Once the cause of the fault is removed the green LED lights up indicating the ON state and the node will re-start to operate.

This module is counted as four 8 digital Inputs modules.

The Maximum number of 2 analogue Inputs modules supported is 1 for CANopen®, DeviceNet, PROFIBUS DP and EtherCAT®.

The Maximum number of 2 analogue Inputs modules supported is 2 for PROFINET IO RT, EtherNet/IP and Powerlink.

**Scheme / Overall dimensions and I/O layout :**

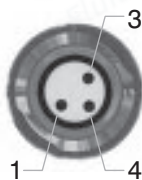
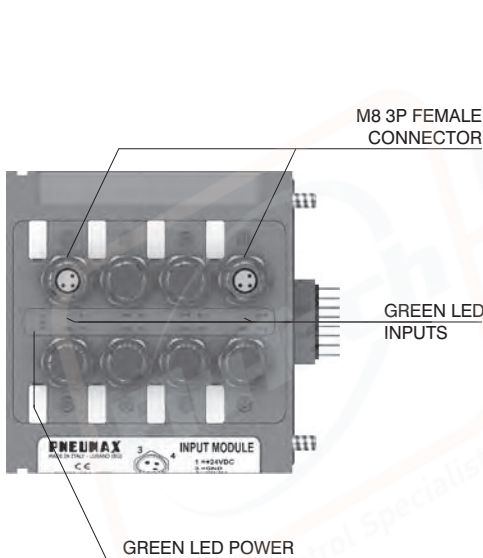

PIN	DESCRIPTION
1	+24 VDC
4	INPUT
3	GND

**Ordering code**

5225.2 \_ . \_ \_ F

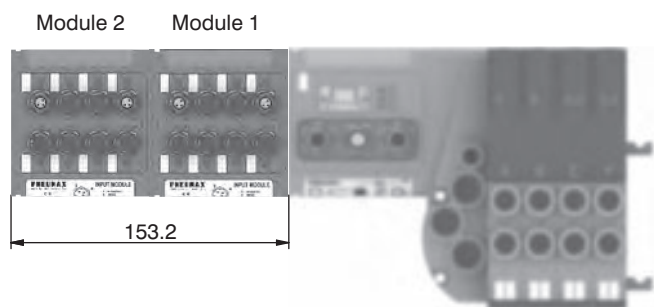
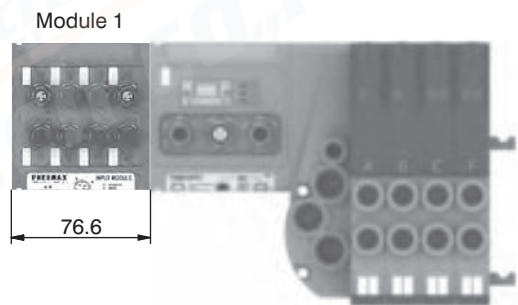

1  
AIR DISTRIBUTION

Socket for Power Supply  
STRAIGHT CONNECTOR  
M12A 4P FEMALE

Ordering code

5312A.F04.00



POWER SUPPLY connector

Upper view  
Slave connector

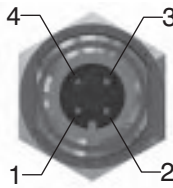

PIN	DESCRIPTION
1	+24 VDC Node
2	
3	0 V
4	+24 VDC Outputs

Socket for Bus CANopen®/DeviceNet  
STRAIGHT CONNECTOR  
M12A 5P FEMALE

Ordering code

5312A.F05.00

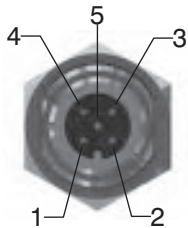

Upper view  
Slave connector

PIN	DESCRIPTION
1	(CAN_SHIELD)
2	(CAN_V+)
3	CAN_GND
4	CAN_H
5	CAN_L

NETWORK connectors

Plug for Bus CANopen®/DeviceNet  
STRAIGHT CONNECTOR  
M12A 5P MALE

Ordering code

5312A.M05.00

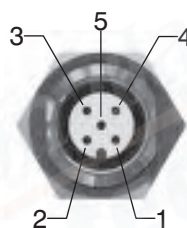

Plug for Bus EtherCAT®,  
PROFINET IO RT,  
EtherNet/IP and Powerlink  
STRAIGHT CONNECTOR M12D 4P MALE

Ordering code

5312D.M04.00



PIN	SIGNAL	DESCRIPTION
1	TX+	Ethernet Transmit High
2	RX+	Ethernet Receive High
3	TX-	Ethernet Transmit Low
4	RX-	Ethernet Receive Low

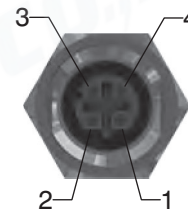

Upper view  
Slave connector

Socket for Bus PROFIBUS DP  
STRAIGHT CONNECTOR  
M12B 5P FEMALE

Ordering code

5312B.F05.00

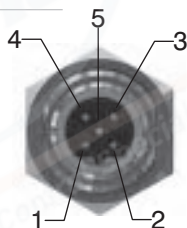

Upper view  
Slave connector

PIN	DESCRIPTION
1	Power Supply
2	A-line
3	DGND
4	B-line
5	SHIELD

Plug for Bus PROFIBUS DP  
STRAIGHT CONNECTOR  
M12B 5P MALE

Ordering code

5312B.M05.00

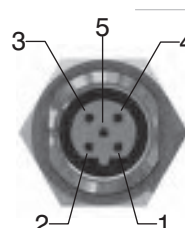

Plug for Input module  
STRAIGHT CONNECTOR  
M8 3P MALE

Ordering code

5308A.M03.00

INPUT connectors

Upper view  
Slave connector

PIN	DESCRIPTION
1	+24 VDC
4	INPUT
3	GND

M12 plug

Ordering code

5300.T12



Plugs

M8 plug

Ordering code

5300.T08

