

Series 2200 "OPTYMA-S"

General

Optyma32-S has been designed in order to complete the Optyima series of valves. Optyima-S, 12.5mm size, integrates all the technical features already developed and implemented on the Optima T & F such as the integrated electrical connection. Further technical specifications are:

- Flow rate: up to 550[Nl/min], using the modular base with Ø8 quick fitting tube.
- Modular base available with Ø4, Ø6, Ø8 quick fitting tube.
- The solenoid pilots are low consumption and fitted on the same side of the valve.
- Mono and bistable valves have the same dimension.
- Easy and fast assembly on the sub base thanks to the "one screw" mounting solution.
- Possibility to replace a valve without the need of disconnecting the pneumatic pipes.
- Electrical and pneumatic connections positioned on the same side.
- Possibility to operate with different pressures and vacuum.
- Management of 32 electrical signals, (16 bi-stable or any combination off mono and bi-stable vales up to max 32 signals).
- The protection grade is IP65 directly integrated in the manifold components.
- The electrical connection is achieved thanks to a 37 pole connector.
- Possibility to integrate with Field Bus modules CANopen®, PROFIBUS DP, DeviceNet, EtherNet/IP, PROFINET IO RT/IRT, EtherCAT®, Powerlink and Modbus/TCP.

"Shifting time of pneumatic directional control valves or moving parts, logic devices were measured in accordance to ISO 12238:2001, Pneumatic fluid power-Directional control valves-Measurement of shifting time"

Main characteristics

One size: 12.5mm thick
Monostable and bistable valves with same dimensions
Modular subbase with two positions
Modular subbases assembled via tie rods
Quick coupling connections directly integrated in sub base
Integrated and optimized electrical connection system.
IP65 protection grade as standard

Construction characteristics

Body	Technopolymer
Operators	Technopolymer
Spacers	NBR
Spacer	Technopolymer
Spools	AISI 303 stainless steel
Springs	AISI 303 stainless steel
Pistons	Technopolymer
Piston seals	NBR

Functions

SV 5/2 MONOSTABLE SOLENOID-SPRING
SV 5/2 MONOSTABLE SOLENOID-DIFFERENTIAL
SV 5/2 BISTABLE SOLENOID-SOLENOID
SV 5/3 C.C. SOLENOID-SOLENOID
SV 2x3/2 N.C.-N.C. (=5/3 O.C.) SOLENOID-SOLENOID
SV 2x3/2 N.O.-N.O. (=5/3 P.C.) SOLENOID-SOLENOID
SV 2x3/2 N.C.-N.O. SOLENOID-SOLENOID
SV 2x3/2 N.O.-N.C. SOLENOID-SOLENOID

Technical characteristics

Voltage	24VDC ±10% PNP (NPN and AC on request)
Pilot consumption	0,5 Watt
Pilot working pressure (12-14)	from 2,5 to 7 bar max.
Valve working pressure [1]	from vacuum to 10 bar max.
Operating temperature	from -5°C to +50°C
Protection degree	IP65
Life (standard operating conditions)	50000000
Fluid	Filtered air. No lubrication needed, if applied it shall be continuous





Solenoid - Spring

Coding: 2241.52.00.39.

Operational characteristics	
Fluid	Filtered air. No lubrication needed, if applied it shall be continuous
Working pressure (bar)	From vacuum to 10
Pressure range (bar)	2,5 ÷ 7
Temperature °C	-5 ÷ +50
Flow rate at 6 bar with Δp=1 (NI/min)	550
Response time according to ISO 12238, activation time (ms)	12
Response time according to ISO 12238, deactivation time (ms)	20

VOLTAGE
02 = 24 VDC PNP
12 = 24 VDC NPN
05 = 24 VAC
SHORT FUNCTION CODE "A"
Weight 67 g

Shifting time of pneumatic directional control valves or moving parts, logic devices were measured in accordance to ISO 12238:2001

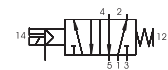
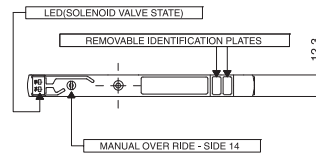
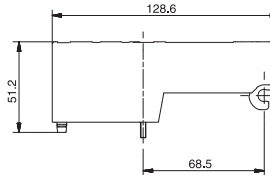

Flow rate at 6 bar with Δp=1 (NI/min) with Base cod. 2244.01. tube Ø4= 140
Flow rate at 6 bar with Δp=1 (NI/min) with Base cod. 2246.01. tubo Ø6= 400
Flow rate at 6 bar with Δp=1 (NI/min) with Base cod. 2246.01. tubo Ø8= 550

Solenoid-Differential

Coding: 2241.52.00.36.

Operational characteristics	
Fluid	Filtered air. No lubrication needed, if applied it shall be continuous
Working pressure (bar)	From vacuum to 10
Pressure range (bar)	2,5 ÷ 7
Temperature °C	-5 ÷ +50
Flow rate at 6 bar with Δp=1 (NI/min)	550
Response time according to ISO 12238, activation time (ms)	20
Response time according to ISO 12238, deactivation time (ms)	25

VOLTAGE
02 = 24 VDC PNP
12 = 24 VDC NPN
05 = 24 VAC
SHORT FUNCTION CODE "B"
Weight 67 g

Shifting time of pneumatic directional control valves or moving parts, logic devices were measured in accordance to ISO 12238:2001

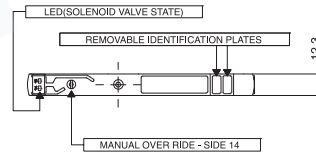
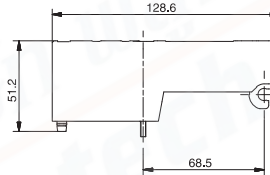
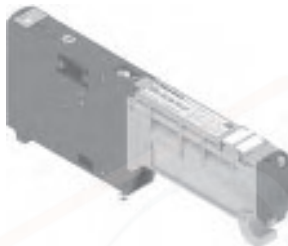

Flow rate at 6 bar with Δp=1 (NI/min) with Base cod. 2244.01. tube Ø4= 140
Flow rate at 6 bar with Δp=1 (NI/min) with Base cod. 2246.01. tubo Ø6= 400
Flow rate at 6 bar with Δp=1 (NI/min) with Base cod. 2246.01. tubo Ø8= 550

Solenoid-Solenoid

Coding: 2241.52.00.35.

Operational characteristics	
Fluid	Filtered air. No lubrication needed, if applied it shall be continuous
Working pressure (bar)	From vacuum to 10
Pressure range (bar)	2,5 ÷ 7
Temperature °C	-5 ÷ +50
Flow rate at 6 bar with Δp=1 (NI/min)	550
Response time according to ISO 12238, activation time (ms)	10
Response time according to ISO 12238, deactivation time (ms)	10

VOLTAGE
02 = 24 VDC PNP
12 = 24 VDC NPN
05 = 24 VAC
SHORT FUNCTION CODE "C"
Weight 67 g

Shifting time of pneumatic directional control valves or moving parts, logic devices were measured in accordance to ISO 12238:2001

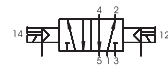
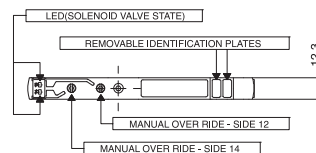
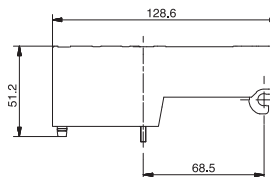

Flow rate at 6 bar with Δp=1 (NI/min) with Base cod. 2244.01. tube Ø4= 140
Flow rate at 6 bar with Δp=1 (NI/min) with Base cod. 2246.01. tubo Ø6= 400
Flow rate at 6 bar with Δp=1 (NI/min) with Base cod. 2246.01. tubo Ø8= 550

1
AIR DISTRIBUTION

Solenoid-Solenoid 5/3 (Closed centres)

Coding: 2241.53.31.35.

Operational characteristics	
Fluid	Filtered air. No lubrication needed, if applied it shall be continuous
Working pressure (bar)	From vacuum to 10
Pressure range (bar)	2,5 ÷ 7
Temperature °C	-5 ÷ +50
Flow rate at 6 bar with Δp=1 (NI/min)	400
Response time according to ISO 12238, activation time (ms)	15
Response time according to ISO 12238, deactivation time (ms)	20

VOLTAGE
02 = 24 VDC PNP
12 = 24 VDC NPN
05 = 24 VAC
SHORT FUNCTION CODE "E" Weight 83 g

Shifting time of pneumatic directional control valves or moving parts, logic devices were measured in accordance to ISO 12238:2001

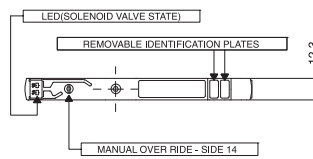
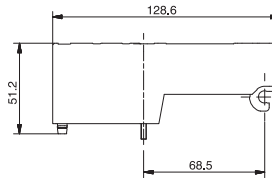
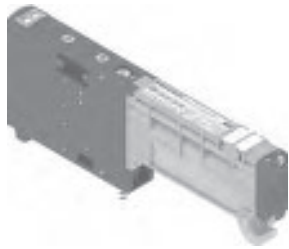

Flow rate at 6 bar with Δp=1 (NI/min) with Base cod. 2244.01. tube Ø4= 140
Flow rate at 6 bar with Δp=1 (NI/min) with Base cod. 2246.01. tube Ø6= 300
Flow rate at 6 bar with Δp=1 (NI/min) with Base cod. 2246.01. tubo Ø8= 400

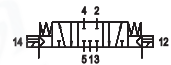

Solenoid-Solenoid 2x3/2

Coding: 2241.62. 35.

Operational characteristics	
Fluid	Filtered air. No lubrication needed, if applied it shall be continuous
Working pressure (bar)	From vacuum to 10
Pressure range (bar)	≥3+(0,2xInlet pressure)
Temperature °C	-5 ÷ +50
Flow rate at 6 bar with Δp=1 (NI/min)	420
Response time according to ISO 12238, activation time (ms)	15
Response time according to ISO 12238, deactivation time (ms)	25

FUNCTION
44 = NC-NC (5/3 Open centres)
45 = NC-NO (normally closed-normally open)
54 = NO-NC (normally open-normally closed)
55 = NO-NO (5/3 Pressured centres)
VOLTAGE
02 = 24 VDC PNP
12 = 24 VDC NPN
05 = 24 VAC

SHORT FUNCTION CODE:
NC-NC (5/3 Open centres)="F"
NO-NO (5/3 Pressured centres)="G"
NC-NO="H"
NO-NC="I"
Weight 75 g

Shifting time of pneumatic directional control valves or moving parts, logic devices were measured in accordance to ISO 12238:2001

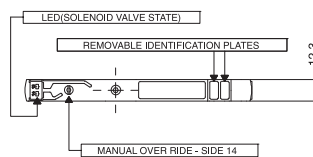
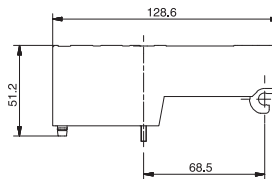
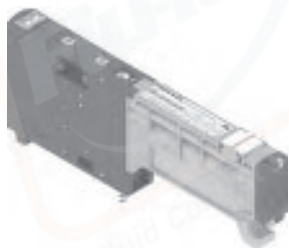

Flow rate at 6 bar with Δp=1 (NI/min) with Base cod. 2244.01. tube Ø4= 140
Flow rate at 6 bar with Δp=1 (NI/min) with Base cod. 2246.01. tubo Ø6= 360
Flow rate at 6 bar with Δp=1 (NI/min) with Base cod. 2246.01. tubo Ø8= 420

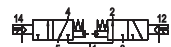
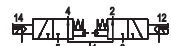
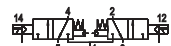



Left Endplates

Coding: 2240.V.C

Operational characteristics	
Fluid	Filtered air. No lubrication needed, if applied it shall be continuous
Working pressure (bar)	From vacuum to 10 (External pilot base) 2,5-7 (Self-feeding base)
Pressure range (bar)	2,5 ÷ 7 (External pilot base)
Temperature °C	-5 ÷ +50

VERSION	
V	02 = External feeding
	12 = Self-feeding
ELECTRICAL CONNECTION	
37P	= Connectors 37 poles
PNP	
25P	= Connectors 25 poles
PNP	
37N	= Connectors 37 poles
C	NPN
25N	= Connectors 25 poles
NPN	
37A	= Connectors 37 poles
AC	
25A	= Connectors 25 poles
AC	

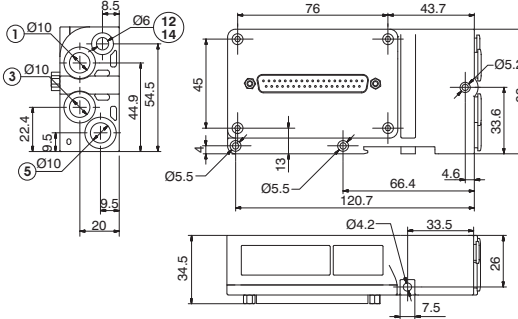

Weight 174 g
12/14 separated from port 1

2240.02.C

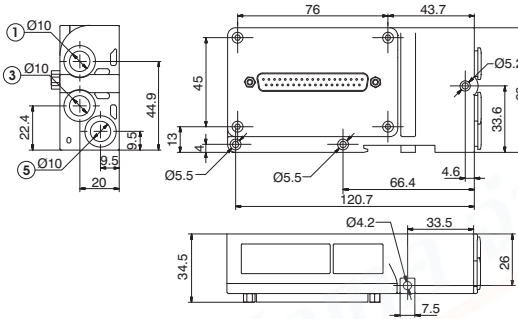

Weight 174 g
12/14 connected to port 1

2240.12.C

Right Endplates

Coding: 2240.03.C

Operational characteristics	
Fluid	Filtered air. No lubrication needed, if applied it shall be continuous
Working pressure (bar)	From vacuum to 10
Pressure range (bar)	2,5 ÷ 7
Temperature °C	-5 ÷ +50

ELECTRICAL CONNECTION	
C	00 = Electrical connection
25P	= Connectors 25 poles

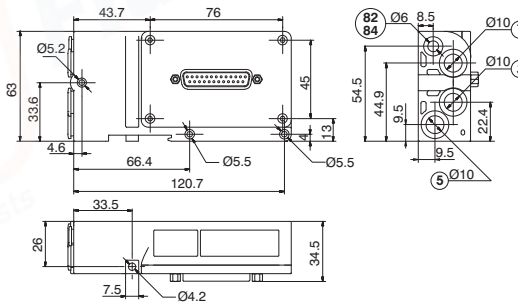

Weight 147 g
PORT 82/84= DO NOT PRESSURIZE, SOLENOID PILOTS EXHAUST

Closing plate

Coding: 2240.00

Operational characteristics	
Fluid	Filtered air. No lubrication needed, if applied it shall be continuous
Working pressure (bar)	From vacuum to 10
Temperature °C	-5 ÷ +50

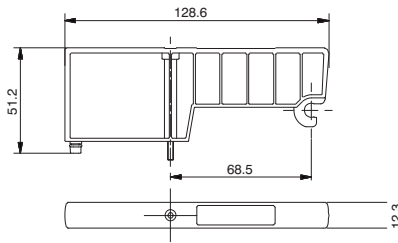

Weight 30 g
SHORT FUNCTION CODE "T"

Intermediate Inlet/Exhaust module

Coding: 2240.10

Operational characteristics	
Fluid	Filtered air. No lubrication needed, if applied it shall be continuous
Working pressure (bar)	From vacuum to 10
Temperature °C	-5 ÷ +50

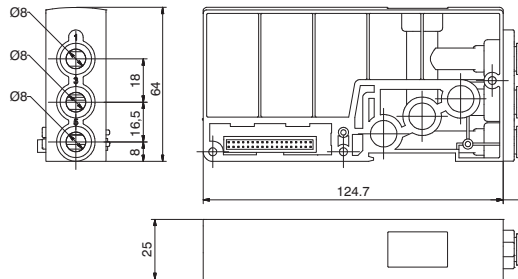

Weight 105 g
SHORT FUNCTION CODE "W"

Modular base (2 places)

Coding: 224C.F.V

Operational characteristics	
Fluid	Filtered air. No lubrication needed, if applied it shall be continuous
Working pressure (bar)	From vacuum to 10
Temperature °C	-5 ÷ +50



2244.F.V

Weight 75 g

SHORT FUNCTION CODE "3" (Monostable) Opened ports
SHORT FUNCTION CODE "33" (Monostable) Ports 1-5 separated
SHORT FUNCTION CODE "34" (Monostable) Ports 1-3 separated
SHORT FUNCTION CODE "35" (Monostable) Port 5 separated
SHORT FUNCTION CODE "36" (Monostable) Separated ports
SHORT FUNCTION CODE "37" (Monostable) Port 1 separated
SHORT FUNCTION CODE "38" (Monostable) Ports 3-5 separated
SHORT FUNCTION CODE "39" (Monostable) Port 3 separated

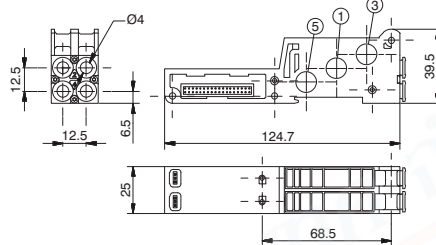

SHORT FUNCTION CODE "4" (Bistable) Opened ports
SHORT FUNCTION CODE "43" (Bistable) Ports 1-5 separated
SHORT FUNCTION CODE "44" (Bistable) Ports 1-3 separated
SHORT FUNCTION CODE "45" (Bistable) Port 5 separated
SHORT FUNCTION CODE "46" (Bistable) Separated ports
SHORT FUNCTION CODE "47" (Bistable) Port 1 separated
SHORT FUNCTION CODE "48" (Bistable) Ports 3-5 separated
SHORT FUNCTION CODE "49" (Bistable) Port 3 separated

TUBE DIAMETER	
C	4 = Ø4
	6 = Ø6
	8 = Ø8
FUNCTION	
	01 = Opened ports
	03 = Ports 1-5 separated
	04 = Ports 1-3 separated
F	05 = Ports 5 separated
	06 = Separated ports
	07 = Ports 1 separated
	08 = Ports 3-5 separated
	09 = Ports 3 separated
VERSION	
V	M = for Monostable SV
	B = for Bistable SV



2246.F.V

Weight 75 g

SHORT FUNCTION CODE "5" (Monostable) Opened ports
SHORT FUNCTION CODE "53" (Monostable) Ports 1-5 separated
SHORT FUNCTION CODE "54" (Monostable) Ports 1-3 separated
SHORT FUNCTION CODE "55" (Monostable) Port 5 separated
SHORT FUNCTION CODE "56" (Monostable) Separated ports
SHORT FUNCTION CODE "57" (Monostable) Port 1 separated
SHORT FUNCTION CODE "58" (Monostable) Ports 3-5 separated
SHORT FUNCTION CODE "59" (Monostable) Port 3 separated

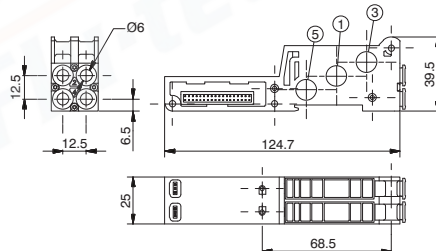

SHORT FUNCTION CODE "6" (Bistable) Opened ports
SHORT FUNCTION CODE "63" (Bistable) Ports 1-5 separated
SHORT FUNCTION CODE "64" (Bistable) Ports 1-3 separated
SHORT FUNCTION CODE "65" (Bistable) Port 5 separated
SHORT FUNCTION CODE "66" (Bistable) Separated ports
SHORT FUNCTION CODE "67" (Bistable) Port 1 separated
SHORT FUNCTION CODE "68" (Bistable) Ports 3-5 separated
SHORT FUNCTION CODE "69" (Bistable) Port 3 separated



2248.F.V

Weight 75 g

SHORT FUNCTION CODE "7" (Monostable) Opened ports
SHORT FUNCTION CODE "73" (Monostable) Ports 1-5 separated
SHORT FUNCTION CODE "74" (Monostable) Ports 1-3 separated
SHORT FUNCTION CODE "75" (Monostable) Port 5 separated
SHORT FUNCTION CODE "76" (Monostable) Separated ports
SHORT FUNCTION CODE "77" (Monostable) Port 1 separated
SHORT FUNCTION CODE "78" (Monostable) Ports 3-5 separated
SHORT FUNCTION CODE "79" (Monostable) Port 3 separated

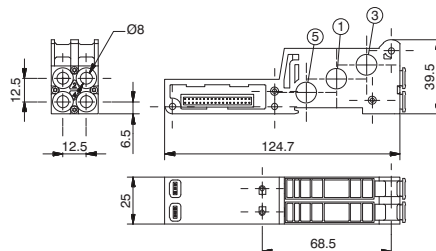

SHORT FUNCTION CODE "8" (Bistable) Opened ports
SHORT FUNCTION CODE "83" (Bistable) Ports 1-5 separated
SHORT FUNCTION CODE "84" (Bistable) Ports 1-3 separated
SHORT FUNCTION CODE "85" (Bistable) Port 5 separated
SHORT FUNCTION CODE "86" (Bistable) Separated ports
SHORT FUNCTION CODE "87" (Bistable) Port 1 separated
SHORT FUNCTION CODE "88" (Bistable) Ports 3-5 separated
SHORT FUNCTION CODE "89" (Bistable) Port 3 separated



1
AIR DISTRIBUTION

Polyethylene Silencer Series SPL-R

Coding: SPLR.ⓐ



TUBE DIAMETER	
ⓐ	6 = 6 mm
	10 = 10 mm

Diaphragm plug

Coding: 2230.17



Weight 6,5 g

Tie-rod M3

Coding: 2240.KD.00



The Kit includes 6 pieces

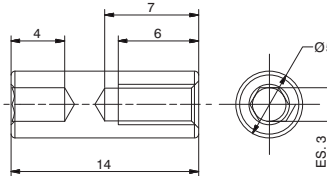

Tie-rod M3

Coding: 2240.KT.ⓐ



The Kit includes 3 pieces

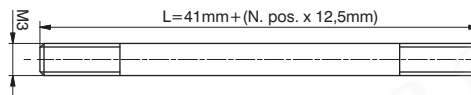

N. POSITIONS	
02	= Nr. 2 Positions
04	= Nr. 4 Positions
06	= Nr. 6 Positions
08	= Nr. 8 Positions
10	= Nr. 10 Positions
12	= Nr. 12 Positions
14	= Nr. 14 Positions
ⓐ	16 = Nr. 16 Positions
18	= Nr. 18 Positions
20	= Nr. 20 Positions
22	= Nr. 22 Positions
24	= Nr. 24 Positions
26	= Nr. 26 Positions
28	= Nr. 28 Positions
30	= Nr. 30 Positions
32	= Nr. 32 Positions

Cable complete with connector, 25 Poles IP65

Coding: 2300.25.ⓐ.ⓐ



CABLE LENGTH	
ⓐ	03 = 3 meters
	05 = 5 meters
	10 = 10 meters
FUNCTION	
ⓐ	31 = Closed centres
	32 = Open centres
	33 = Pressured centres

Cable complete with connector, 37 Poles IP65

Coding: 2400.37.ⓐ.ⓐ



CABLE LENGTH	
ⓐ	03 = 3 meters
	05 = 5 meters
	10 = 10 meters
FUNCTION	
ⓐ	31 = Closed centres
	32 = Open centres
	33 = Pressured centres

Cable complete with connector, 25 Poles IP65

Coding: 2400.25.ⓐ.25



CABLE LENGTH	
ⓐ	03 = 3 meters
	05 = 5 meters
	10 = 10 meters



General :

Using the 2240.03.25P output terminal it is possible to make any electrical signals not used by valves available on a 25 sub-D female connector at the right end of the manifold. It is possible to then join a multi-core cable to link to the next manifold, or connect directly to one or two I/O modules. The I/O modules can accept input or output signals, depending upon what is connected.

Ordering code

2240.08S



Please note: If the manifold is connected by a multi-core connection, each connection can be used as either an input or an output, while if the manifold is connected to a serial node the connections can only be used as an output.

It is possible to connect the manifold to up to two I/O modules.

Each I/O module includes 8 diagnostic LEDs which indicate the presence of an Input / Output signal for each connector.

Please note: For an LED to function, a signal of at least +15VDC must be present on pin 4 of the connector. If this signal is lower, the LED will not light, this does not compromise the normal Input / Output function of the unit.

Overall dimensions and I/O layout:

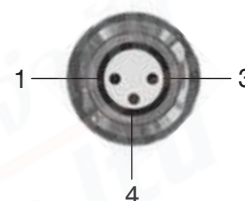
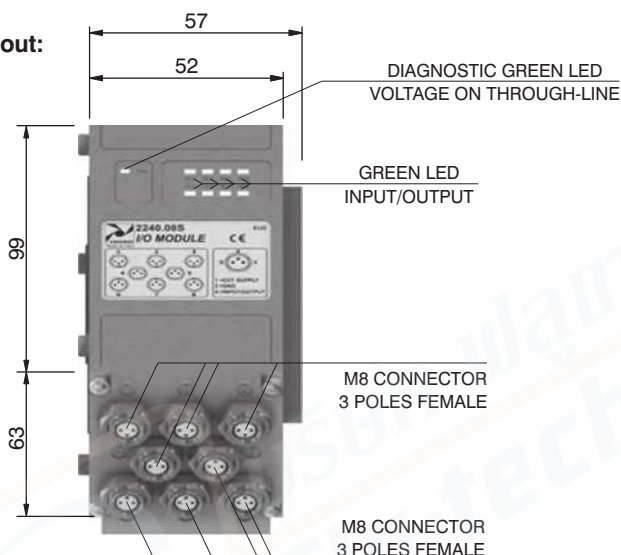

PIN	DESCRIPTION
1	+24 VDC
4	INPUT/OUTPUT
3	GND

Input features:

Each connection can accept either two wire (switches, magnetic switches, pressure switches, etc.) or three wire connections (photocells, electronic end of stroke sensors, etc.) if +24VDC is required on at Pin 1 of each connector, it is possible to provide this via the through-line pin of the multi-pole connector.

I.E.:

Pin 25 of the 25 pin multi-pole connector (code 2240.02.25P or 2240.12.25P)

Pin 36-37 of the 37 pin multi-pole connector (code 2240.02.37P or 2240.12.37P)

Output features:



Attention: The output connections are not protected against short-circuit. Please pay attention when wiring (avoid Pin 4 being connected to Pin 3 or Pin 1).

General characteristics

Model	2240.08S
Case	Reinforced technopolymer
I/O Connector	M8 connector 3 poles female (IEC 60947-5-2)
PIN 1 voltage (connector used as Input)	by the user
PIN 4 voltage diagnosis	Green Led
Node consumption (Outlets excluded)	7mA per each LED with 24 VDC signal
Outlets voltage	+23,3 VDC (serial) /by the user (multipolar)
Input voltage	Depend by the using
Maximum outlet current	100 mA (serial) / 400 mA (multipolar)
Maximum Input/Output	8 per module
Multiconnector max. Current	100 mA
Connections to manifold	Direct connection to 25 poles connector
Maximum n. of moduls	2
Protection degree	IP65 when assembled
Ambient temperature	from -0° to +50° C

1
AIR DISTRIBUTION

CORRESPONDENCE BETWEEN MULTI-POLE SIGNAL AND CONNECTOR

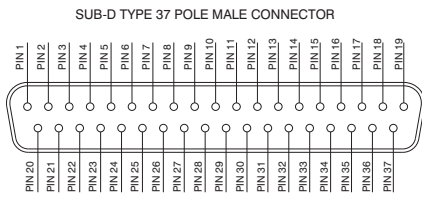

1 - 32 = SIGNALS
 33 - 35 = GND
 36 - 37 = THROUGH LINE

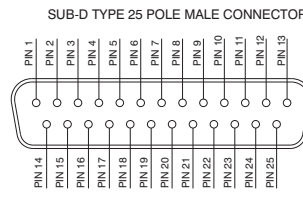

1 - 22 = SIGNALS
 23 - 24 = GND
 25 = THROUGH LINE

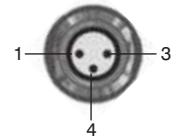

PIN	DESCRIPTION
1	THROUGH LINE
4	SIGNAL
3	GND

Connection modes:

The I/O module changes its operation depending on the way the manifold is controlled. There are two possible modes:

- A) Control via multi-pole connection
- B) Control via fieldbus

A) Control via multi-pole :

M8 connector used as Input:



Attention: Voltage applied to each connector is passed to multi-pole connector pin.

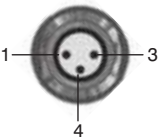

PIN	DESCRIPTION
1	THROUGH LINE
4	SIGNAL
3	GND

In order to use the I/O module, the correct right hand endplate with 25 pole female outlet connector must be used. (Code 2240.03.25P).



M8 connector used as Output:

Output voltage will be the same as is applied at the multi-pole connector pin. The maximum output current depends upon the power unit used, but we recommend no more than 250mA.



Attention: Since every cable has a degree of resistance, there will always be a voltage drop depending on the cable's length, sectional area and the current.

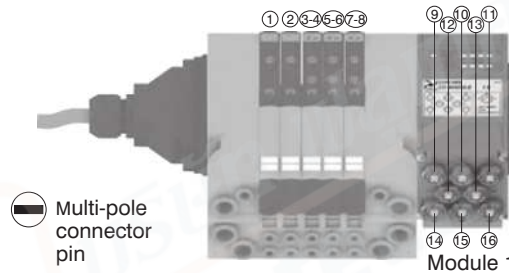

Attention: Only one more I/O module can be added.

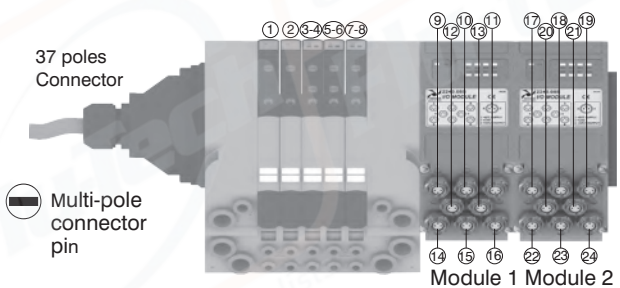

Attention: No more additions are possible

Attention : Optyma 32-S solenoid valve manifolds permit up to 22 electrical signals that are not used by manifolds to be made available: these signals can be managed by another manifold and / or by I/O modules.

The I/O module will manage these unused signals. Connections that are not managing useful signals will remain unconnected.

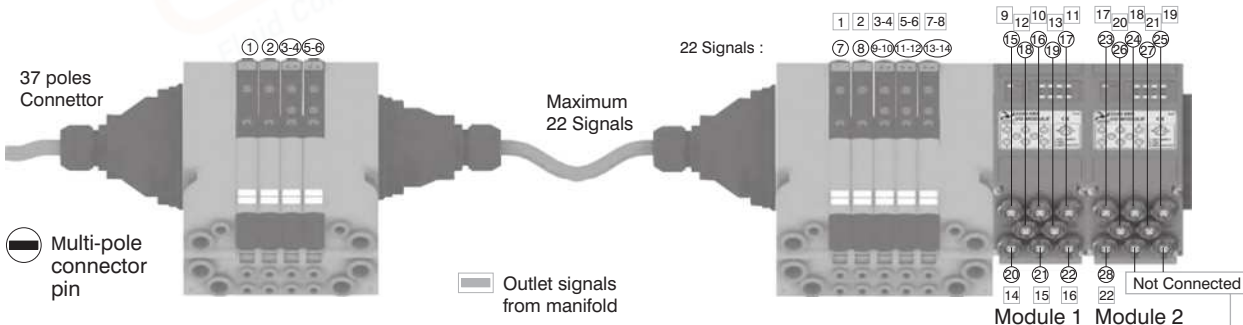

Attention: Signal Not connected
 GND Connected
 Through line Connected

Please note: this example considers a 37 pin multi-pole connector. The same configuration managed by a 25 pin multi-pole connector will stop at number 22 of multi-pole connector and at number 17 of the manifold. 22 16



Please note: Optyma 32-S solenoid valve manifolds manage up to 32 signals. If the manifold uses more than 24 signals the I/O module will manage only the remainder. Connections that are not managing useful signals will remain unconnected.

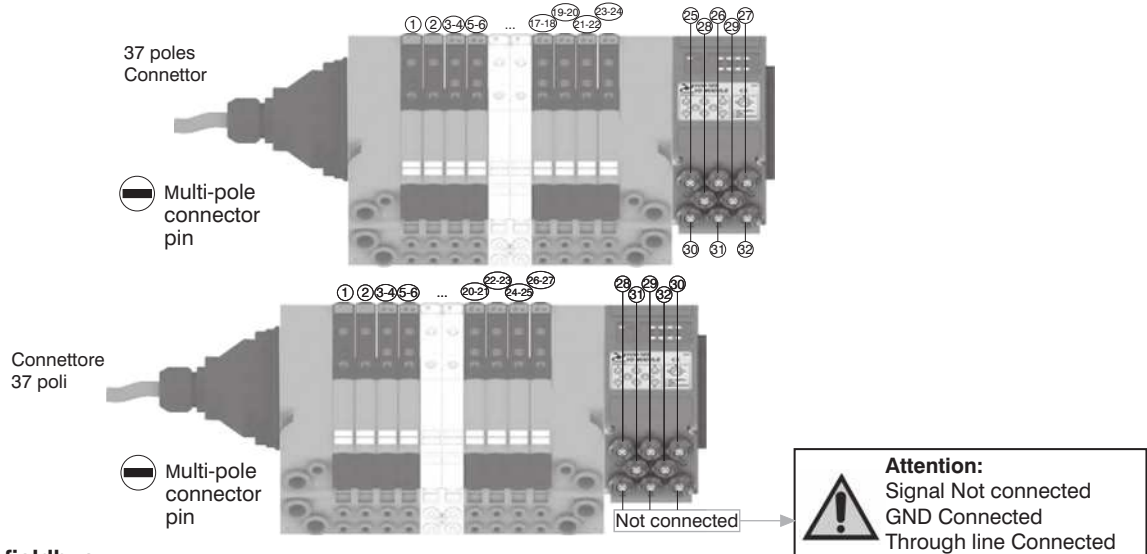

B) Control via fieldbus:

With this kind of control the I/O module can only be used as an output. Pin 1 of each connector is not connected. The output voltage will be 0.7V lower than that applied to Pin 4 of the connector.

The maximum output current for each output is 100mA. The correspondence between control byte and each single output depends on how many electrical signals are used by the manifold and by the relative position of the I/O module.

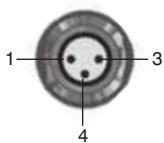

PIN	DESCRIPTION
1	NOT CONNECTED
4	SIGNAL
3	GND

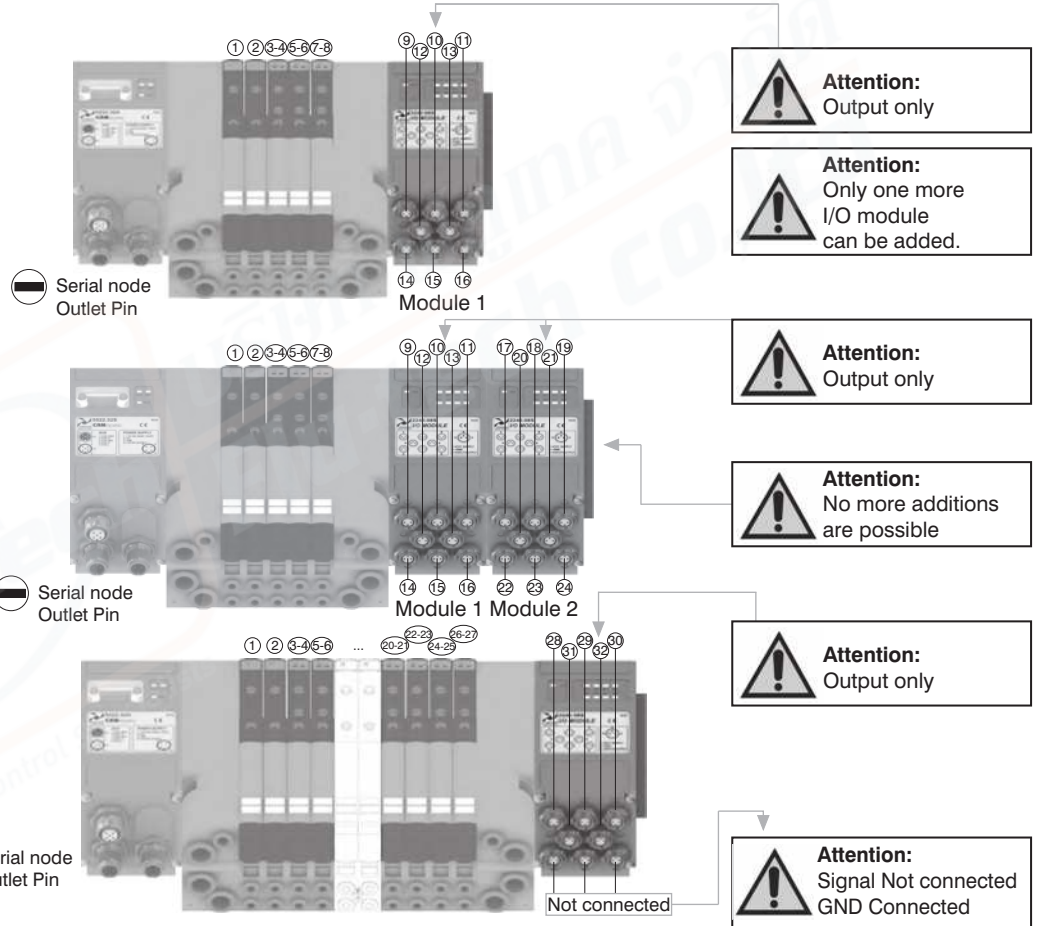

Please note: I/O modules don't allow to connect any additional valves manifold after them.

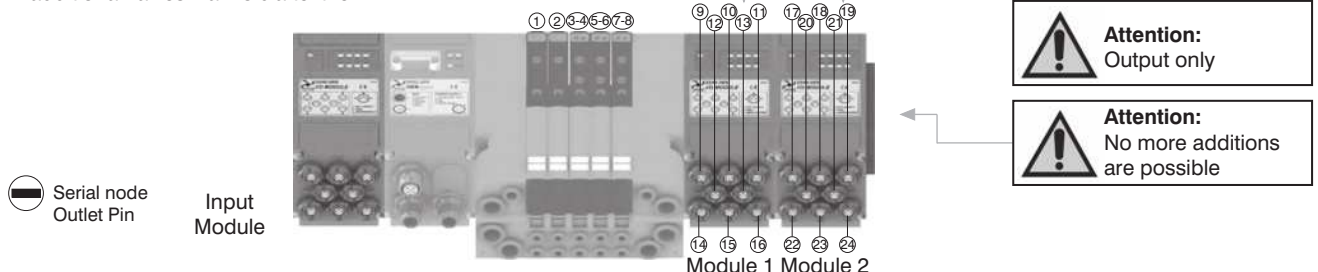



Electrical connection

The electrical connection is made using a 37 pin connector and can manage up to 32 electrical signals. Alternatively a 25 pin connector can be used which is suitable for up to 22 electrical signals. The distributions of the electrical signals between sub-bases achieved thanks to a dedicated electrical connector positioned in each sub-base which diverts the signals needed to operate the solenoid pilots of the valve mounted on the sub-base and passing unused signals forward to the next base.

The Optyima-S sub-bases are designed to carry two valves and are available in the following configurations:

Sub-base configurations	Signals used for the single position	Total number of used signal
Sub-base for 2 bistable valves	2 signals used for the first position	4
	2 signals used for the second position	
Sub-base for 2 monostable valves	1 signal used for the first position	2
	1 signal used for the second position	

Sub-base for 2 bistable valves

On the sub base for 2 bistable valves the first electrical signal is used to actuate the solenoid pilot on side 14 of the first position, the second signal is used to actuate the solenoid pilot on side 12 of the first position. Each sub base uses 4 electric signals. The same layout applies to the following position therefore the third signal is used to actuate the solenoid pilot on side 14 of the second position and the fourth signal is used to actuate the solenoid pilot on side 12 of the second position. The remaining signals are transferred downstream.

On a bistable sub base it is possible to mount both bistable or monostable valves (in the second case 1 electrical signal for each valve is wasted). This solutions enables the user to change the manifold layout without the need to re-configure the output correspondence on the PLC. The use of bistable sub-bases reduces the maximum number of valves that can be mounted on the manifold: If the 37 pole connector is used the maximum number of valves is 16 If the 25 pole connector is used the maximum number of valves is 10.

Sub-base for 2 monostable valves

On the sub base for 2 monostable valves the first electrical signal is used to actuate the solenoid pilot on side 14 of the first position, the second signal is used to actuate the solenoid pilot on side 12 of the second position. Each sub base uses 2 electric signals. The remaining signals are transferred downstream. On a monostable sub base it is possible to mount only monostable valves (shoud a bistable valve be mounted on a monostable sub base it will not be possible to actuate the solenoid pilot on side 12). This solutions enables the user to maximise the manifold lay out using all the electrical signals available.

If the 37 pole connector is used the maximum number of valves is 32
If the 25 pole connector is used the maximum number of valves is 22



Note:

Monostable valves, which are fitted with only one solenoid pilot can be mounted on both monostable or bistable sub bases.
Bistable valves ,5/3; 2x3/2;2x2/2, which are fitted with 2 solenoid pilots and therefore always use two electrical signals must always be mounted on bistable subbases.

Additional exhaust and air supply modules:

The Additional exhaust and air supply module is fitted with a dedicated electrical connector which does not use any electric signal but simply carries forward all signals which have not been used by the valves mounted before it. This enables its use in any position of the manifold.



Unused electrical signals

The electrical signals which have not been used in the manifold can be made available by using the end plate fitted with the 25 pole connector.

The number of electric signals available depends on the type of connector mounted on the inlet plate and on the number of signals used in the manifold:

- 37 pole Inlet connector : N. of outputs= 32 – used signals (max 22)
- 25 pole Inlet connector : N. of outputs= 22 – used signals

Here are some examples of possible configurations and the corresponding pin layout both on the inlet and end plate :

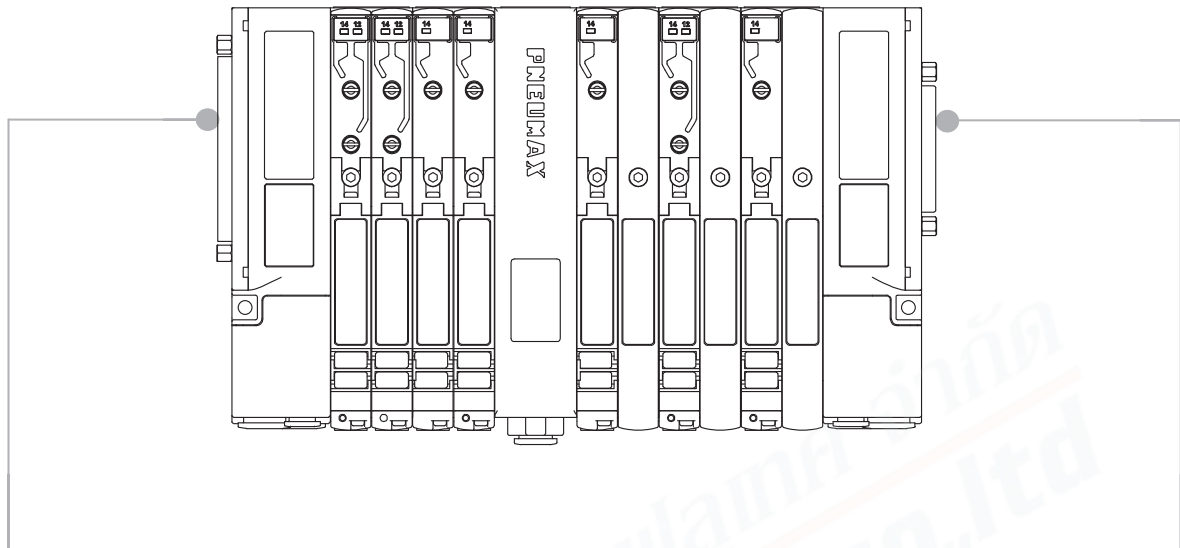

INLET ELECTRIC CONNECTIONS

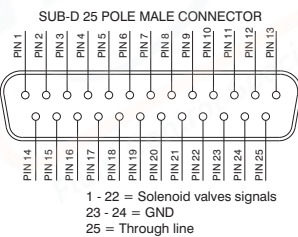
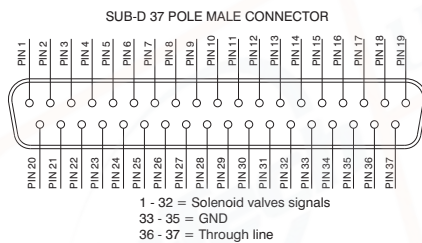

OUTLET ELECTRIC CONNECTIONS (IF PRESENT)

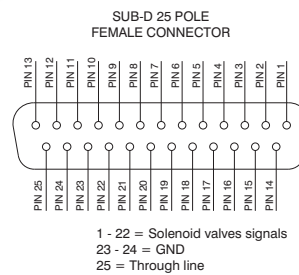

37 PIN Connector correspondence for valves assembled on mixed bases

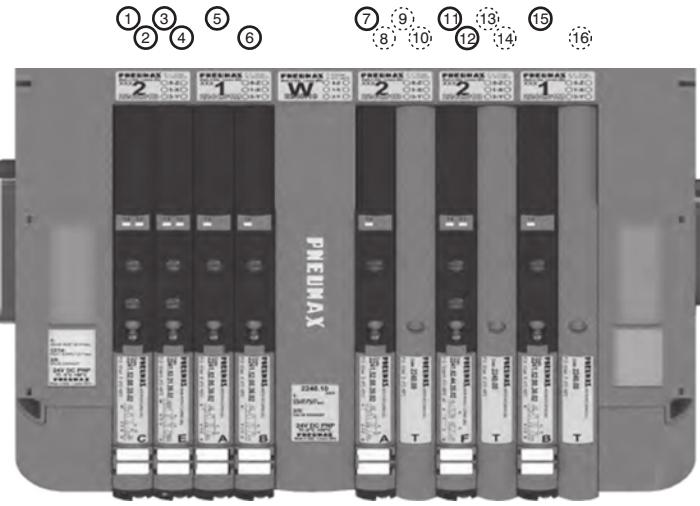

- PIN 1 = PILOT 14 SV POS.1
- PIN 2 = PILOT 12 SV POS.1
- PIN 3 = PILOT 14 SV POS.2
- PIN 4 = PILOT 12 SV POS.2
- PIN 5 = PILOT 14 SV POS.3
- PIN 6 = PILOT 14 SV POS.4
- PIN 7 = PILOT 14 SV POS.6
- PIN 8 = NOT CONNECTED
- PIN 9 = NOT CONNECTED
- PIN 10 = NOT CONNECTED
- PIN 11 = PILOT 14 SV POS.8
- PIN 12 = PILOT 12 SV POS.8
- PIN 13 = NOT CONNECTED
- PIN 14 = NOT CONNECTED
- PIN 15 = PILOT 14 SV POS.10
- PIN 16 = NOT CONNECTED

POS.	1	2	3	4	5	6	7	8	9	10	11
------	---	---	---	---	---	---	---	---	---	----	----

37 PIN Connector correspondence for manifold mounted on bases for bistable valves

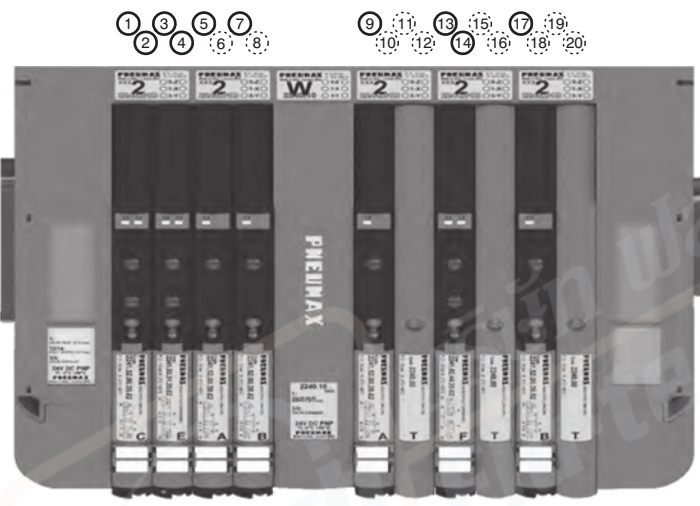

- PIN 1 = PILOT 14 SV POS.1
- PIN 2 = PILOT 12 SV POS.1
- PIN 3 = PILOT 14 SV POS.2
- PIN 4 = PILOT 12 SV POS.2
- PIN 5 = PILOT 14 SV POS.3
- PIN 6 = NOT CONNECTED
- PIN 7 = PILOT 14 SV POS.4
- PIN 8 = NOT CONNECTED
- PIN 9 = PILOT 14 SV POS.6
- PIN 10 = NOT CONNECTED
- PIN 11 = NOT CONNECTED
- PIN 12 = NOT CONNECTED
- PIN 13 = PILOT 14 SV POS.8
- PIN 14 = PILOT 12 SV POS.8
- PIN 15 = NOT CONNECTED
- PIN 16 = NOT CONNECTED
- PIN 17 = PILOT 14 SV POS.10
- PIN 18 = NOT CONNECTED
- PIN 19 = NOT CONNECTED
- PIN 20 = NOT CONNECTED

POS.	1	2	3	4	5	6	7	8	9	10	11
------	---	---	---	---	---	---	---	---	---	----	----

37 PIN Connector correspondence for manifold for 32 position manifold with monostable valves on double bases

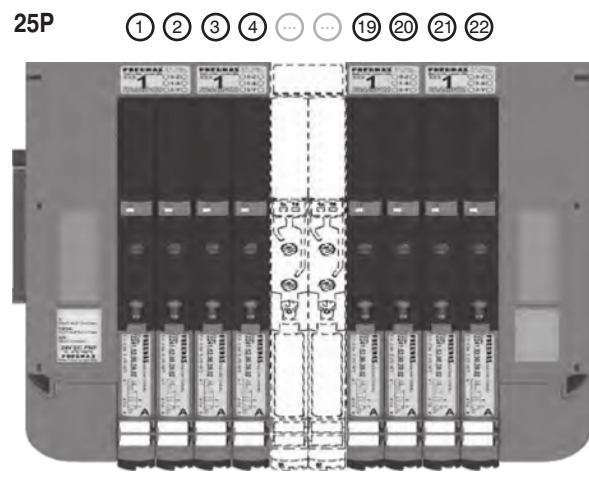
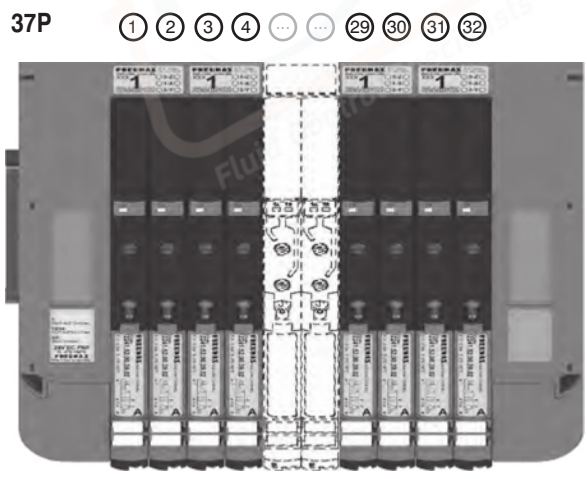

POS.	1	2	3	4	...	29	30	31	32
------	---	---	---	---	-----	----	----	----	----

POS.	1	2	3	4	...	19	20	21	22
------	---	---	---	---	-----	----	----	----	----

1
AIR DISTRIBUTION

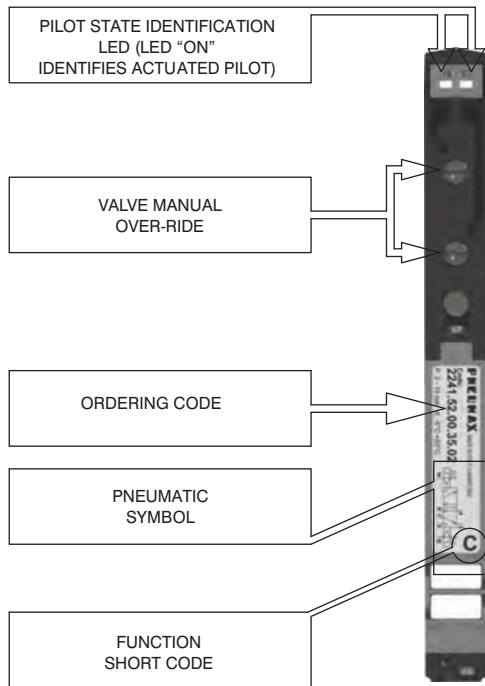

From the top

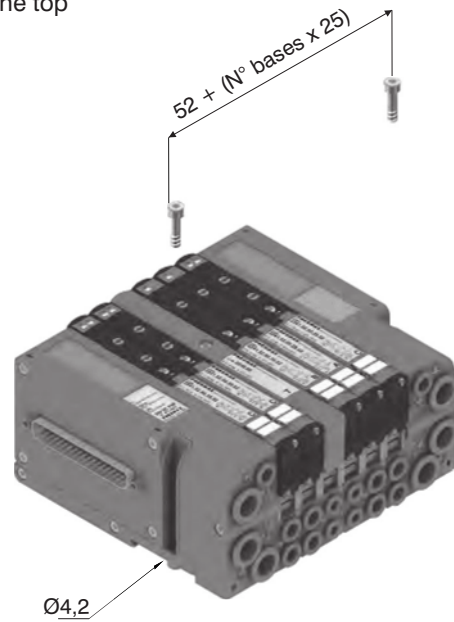

1
AIR DISTRIBUTION

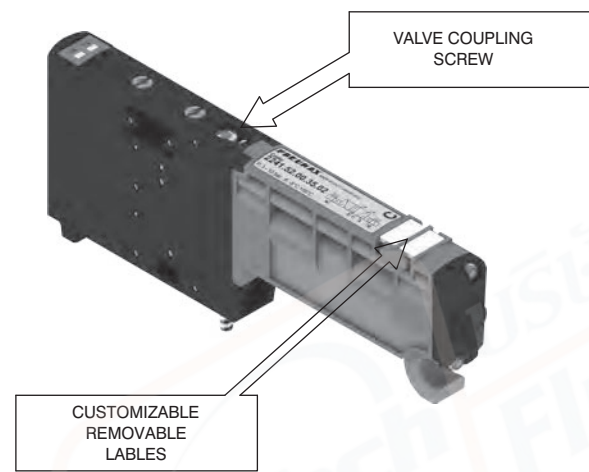

DIN rail fixing

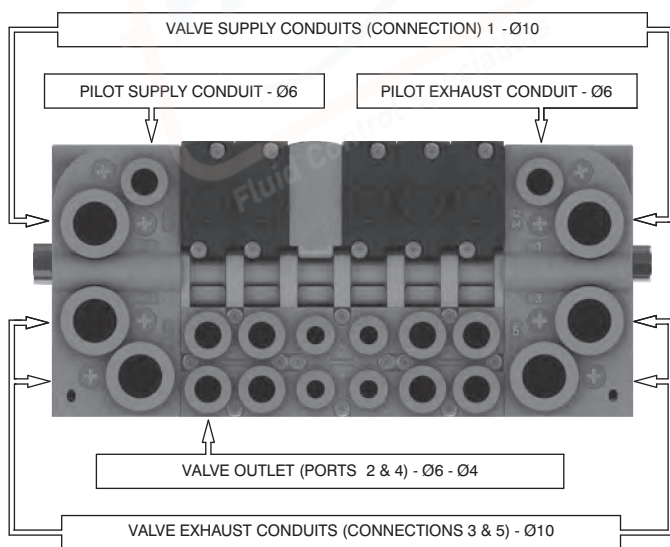
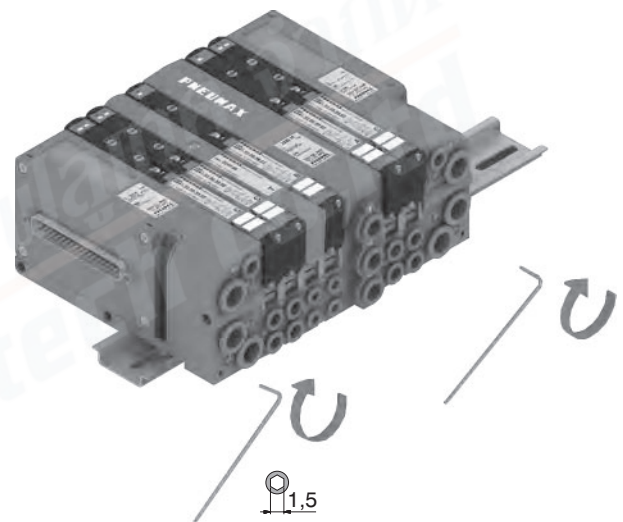

Maximum possible size
According to valves used

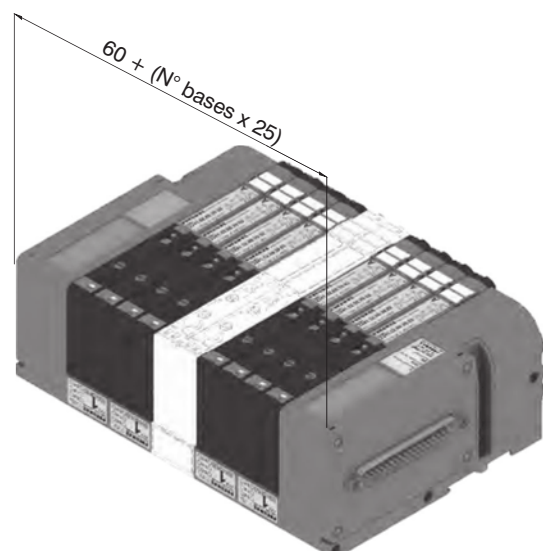

Manual override actuation

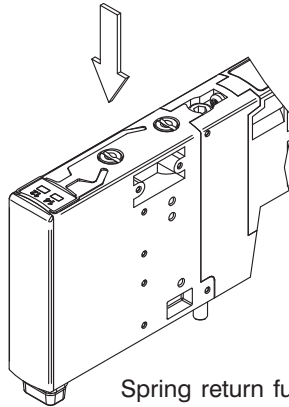
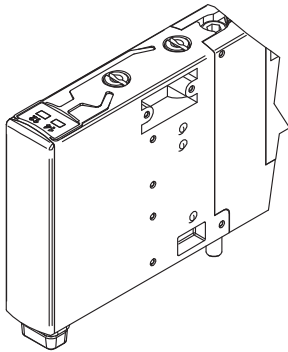

Spring return function: push to actuate (when released it moves back to the original position).

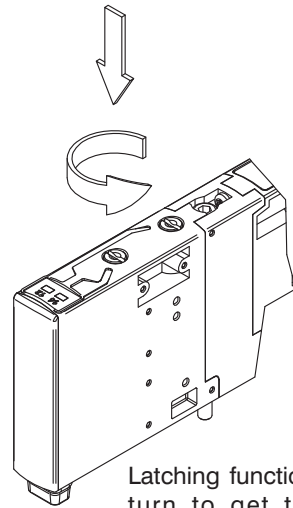

Latching function: push and turn to get the latching function

NOTE : It is strongly suggested to replace the original position after using

Valve Installation

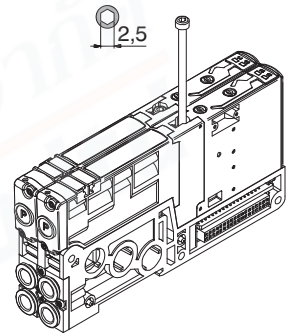
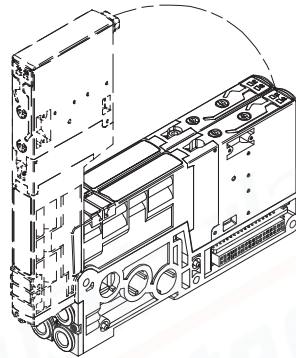
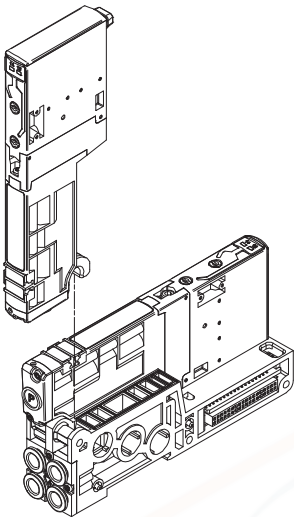

Torque moment (Nm) : 0,8

Manifold assembly

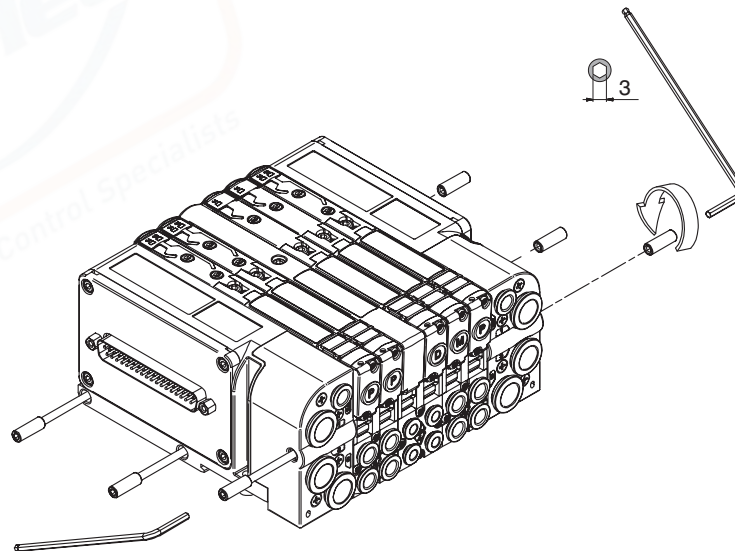

Min. torque moment : 2 Nm
Max. torque moment: 2,5 Nm



Manifold Layout configuration

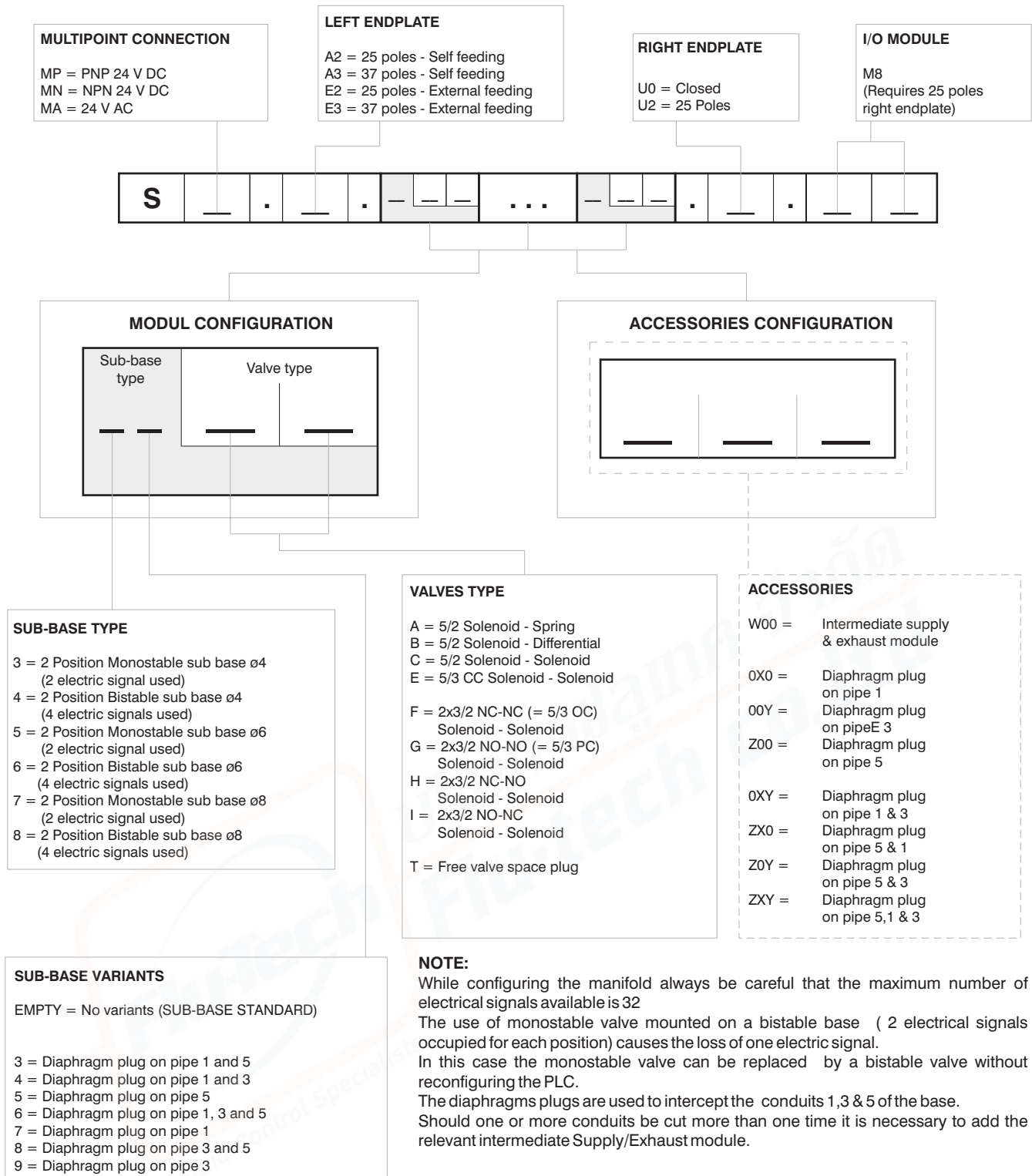

Series 2200 OPTYMA-S solenoid valve manifolds managed by multipoint connection are "well tried components"

	Well-tryed component	<ul style="list-style-type: none"> - The product is a well-tryed product for a safety-related application according to ISO 13849-1. - The relevant basic and well-tryed safety principles according ISO 13849-2 for this product are fulfilled. - The suitability of the product for a precise application must be verified and confirmed by the user.
B_{10d}	50.000.000	

General:

CANopen® module is directly integrated on Optyma-S solenoid valves manifold via a 37 poles connector, normally used for multipolar cable connection.
 Optyma-S solenoid valves connected to node must be PNP equivalent (final 02 in ordering code).

The node can be easily installed also on solenoid valves manifold already mounted on equipment.

Module can manage up to 32 solenoid valves, and, in the same time, a max number of 4 Input modules 5222.08S.

CANopen® module recognizes automatically the presence of the Input modules on power on.

Regardless of the number of Input modules connected, the manageable solenoid valves are 32.

Node power supply is made by a M12 4P male circular connector.

The separation between node 24 VDC Power supply and outputs 24 VDC allows to switch off the outputs maintaining powered the node and inputs, if present.

Connection to Bus CANopen® is possible via 2 M12 5P male - female circular connectors; these two are connected in parallel and according to CiA Draft Recommendation 303-1 (V. 1.3 : 30 December 2004).

Transmission speed can be set by 3 dip-switches.

The node address can be set by 6 dip-switches using BCD numeration.

The module includes an internal terminating resistance that can be activated by a dip-switch.

Ordering code

5522.32S

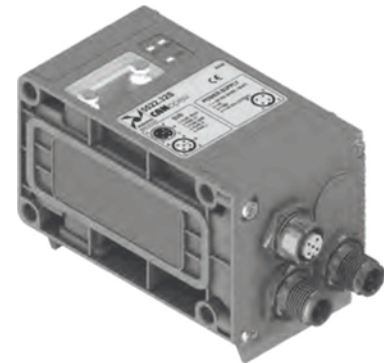

Scheme / Overall dimensions and I/O layout :

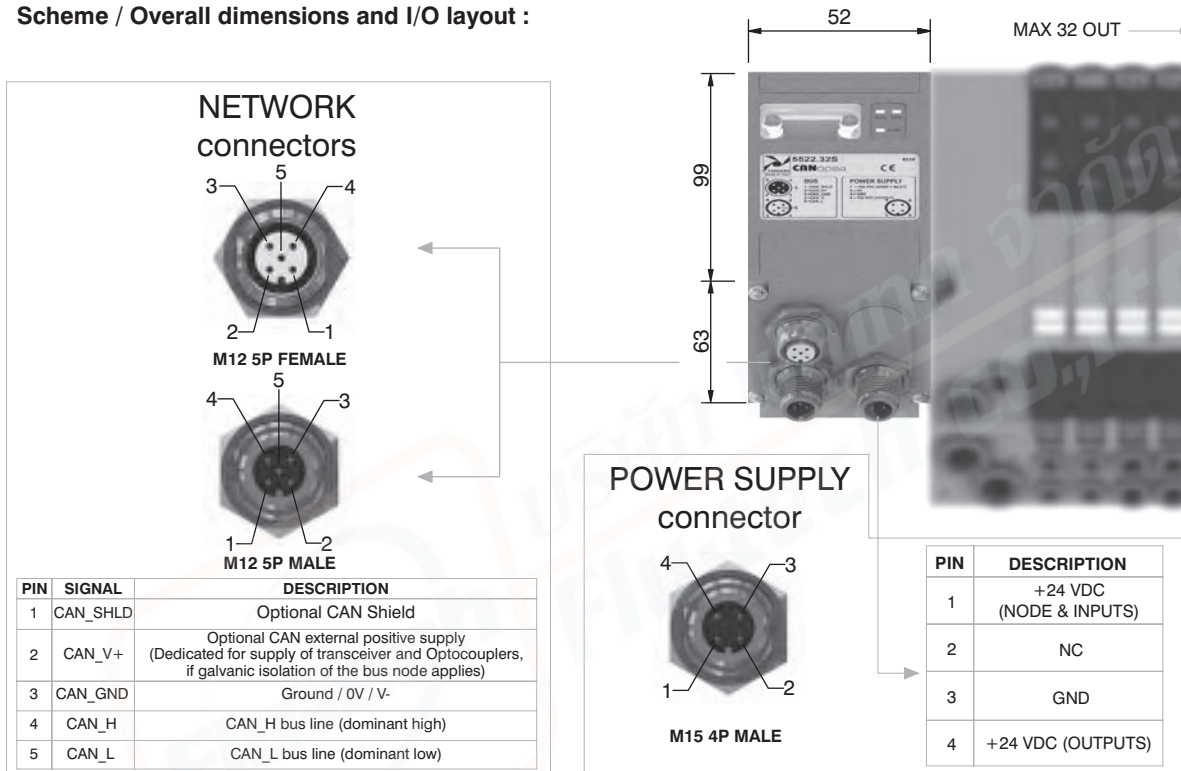

Technical characteristics

Model	5522.32S
Specifications	CiA Draft Standard Proposal 301 V 4.10 (15 August 2006)
Case	Reinforced technopolymer
Power supply	Power supply connection: M12 4P male connector (IEC 60947-5-2)
	Power supply voltage: +24 VDC +/- 10%
	Node consumption (without inputs): 30 mA
	Power supply diagnosis: Green LED PWR
Outputs	PNP equivalent outputs: +24 VDC +/- 10%
	Maximum current for each output: 100 mA
	Maximum output number: 32
	Max output simultaneously actuated: 32
Network	Network connectors: 2 M12 5P connectors male-female Type A (IEC 60947-5-2)
	Baud rate: 10 - 20 - 50 - 125 - 250 - 500 - 800 - 1000 Kbit/s
	Addresses, possible numbers: From 1 to 63
	Max nodes in net: 64 (slave + master)
	Bus maximum recommended length: 100 m at 500 Kbit/s
	Bus diagnosis: Green LED + Red LED
	Configuration file: Available from our web site: http://www.pneumaxspa.com
	IP protection grade: IP65 when assembled
	Temperature range: From 0° to +50° C

General:

DeviceNet module is directly integrated on Optyma-S solenoid valves manifold via a 37 poles connector, normally used for multipolar cable connection.
Optyma-S solenoid valves connected to node must be PNP equivalent (final 02 in ordering code).

The node can be easily installed also on solenoid valves manifold already mounted on equipment.

Module can manage up to 32 solenoid valves, and, in the same time, a max number of 4 Input modules 5222.08S.

DeviceNet module recognizes automatically the presence of the Input modules on power on. Regardless of the number of Input modules connected, the manageable solenoid valves are 32. Node power supply is made by a M12 4P male circular connector.

The separation between node 24 VDC Power supply and outputs 24 VDC allows to switch off the outputs maintaining powered the node and inputs, if present.

Connection to Bus DeviceNet is possible via 2 M12 5P male - female circular connectors; these two are connected in parallel and according to DeviceNet Specifications Volume I, release 2.0. Transmission speed can be set by 3 dip-switches.

The node address can be set by 6 dip-switches using BCD numeration.

The module includes an internal terminating resistance that can be activated by a dip-switch.

Ordering code

5422.32S



Scheme / Overall dimensions and I/O layout :

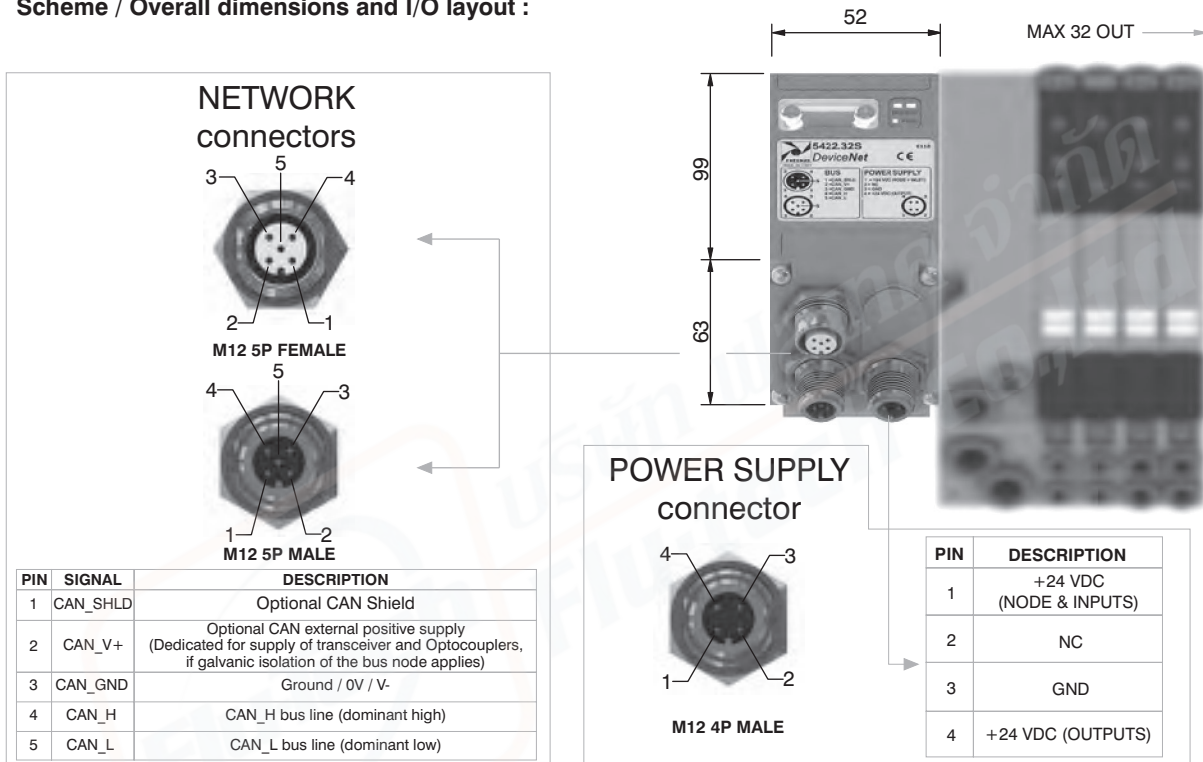

Technical characteristics

Model	5422.32S	
Specifications	DeviceNet Specifications Volume I, release 2.0.	
Case	Reinforced technopolymer	
Power supply	Power supply connection	M12 4P male connector (IEC 60947-5-2)
	Power supply voltage	+24 VDC +/- 10%
	Node consumption (without inputs)	30 mA
	Power supply diagnosis	Green LED PWR
Outputs	PNP equivalent outputs	+24 VDC +/- 10%
	Maximum current for each output	100 mA
	Maximum output number	32
	Max output simultaneously actuated	32
Network	Network connectors	2 M12 5P connectors male-female Type A (IEC 60947-5-2)
	Baud rate	125 - 250 - 500 Kbit/s
	Addresses, possible numbers	From 1 to 63
	Max nodes in net	64 (slave + master)
	Bus maximum recommended length	100 m at 500 Kbit/s
	Bus diagnosis	Green LED + Red LED
	Configuration file	Available from our web site: http://www.pneumaxspa.com
	IP protection grade	IP65 when assembled
	Temperature range	From 0° to +50° C

1
AIR DISTRIBUTION

General:

PROFIBUS DP module is directly integrated on Optyma-S solenoid valves manifold via a 37 poles connector, normally used for multipolar cable connection.

Optyma-S solenoid valves connected to node must be PNP equivalent (final 02 in ordering code). The node can be easily installed also on solenoid valves manifold already mounted on equipment.

Module can manage up to 32 solenoid valves, and, in the same time, a max number of 4 Input modules 5222.08S.

PROFIBUS DP module recognizes automatically the presence of the Input modules on power on. Regardless of the number of Input modules connected, the managable solenoid valves are 32.

Node power supply is made by a M12 4P male circular connector.

The separation between node 24 VDC Power supply and outputs 24 VDC allows to switch off the outputs mantaning powered the node and inputs, if present.

Connection to Bus PROFIBUS DP is possible via 2 M12 type B 5P male - female circular connectors; these two are connected in parallel and according to PROFIBUS Interconnection Technology (Version 1.1 : August 2001).

The node address can be set using BCD numeration: 4 dip-switches for the units and 4 dip-switches for the tens.

The module includes an internal terminating resistance that can be activated by a dip-switch.

Ordering code

5322.32S



Scheme / Overall dimensions and I/O layout :

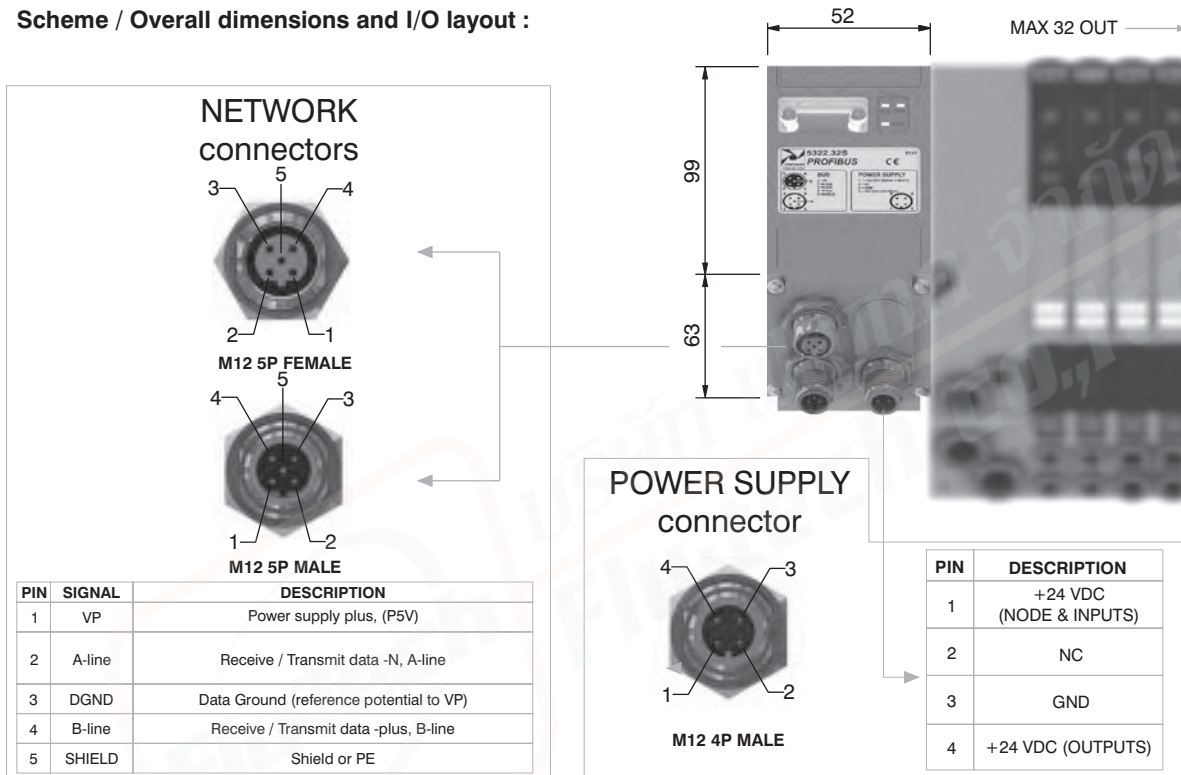

Technical characteristics

Model	5322.32S
Specifications	PROFIBUS DP
Case	Reinforced technopolymer
Power supply	Power supply connection M12 4P male connector (IEC 60947-5-2)
	Power supply voltage +24 VDC +/- 10%
	Node consumption (without inputs) 50 mA
	Power supply diagnosis Green LED PWR
Outputs	PNP equivalent outputs +24 VDC +/- 10%
	Maximum current for each output 100 mA
	Maximum output number 32
	Max output simultaneously actuated 32
Network	Network connectors 2 M12 5P male-female connectors Type B
	Baud rate 9,6 - 19,2 - 93,75 - 187,5 - 500 - 1500 - 3000 - 6000 - 12000 Kbit/s
	Addresses, possible numbers From 1 to 99
	Max nodes in net 100 (slave + master)
	Bus maximum recommended length 100 m at 12 Mbit/s - 1200 m at 9,6 Kbit/s
	Bus diagnosis Green LED + Red LED
	Configuration file Available from our web site: http://www.pneumaxspa.com
	IP protection grade IP65 when assembled
	Temperature range From 0° to +50° C



General:

EtherCAT® module is directly integrated on Optyima-S solenoid valves manifold via a 37 poles connector, normally used for multipolar cable connection.
Optyima-S solenoid valves connected to node must be PNP equivalent (final 02 in ordering code).

The node can be easily installed also on solenoid valves manifold already mounted on equipment.

Module can manage up to 32 solenoid valves, and, in the same time, a max number of 4 Input modules 5222.08S.

The EtherCAT® module, regardless the number of Input module connected, reports to have connected 4 Input modules.

Regardless of the number of Input modules connected, the manageable solenoid valves are 32.

Node power supply is made by a M12 4P male circular connector.

The separation between node 24 VDC Power supply and outputs 24 VDC allows to switch off the outputs maintaining powered the node and inputs, if present.

Connection to Bus EtherCAT® is possible via 2 M12 4P type D female circular connectors. These two connectors lead the signal to two different communication ports, so they are not connected in parallel.

The node address is assigned during configuration.

Note: 5700 series has a different configuration file from series 5600.

Ordering code

5722.32S.EC



1
AIR DISTRIBUTION

Scheme / Overall dimensions and I/O layout :

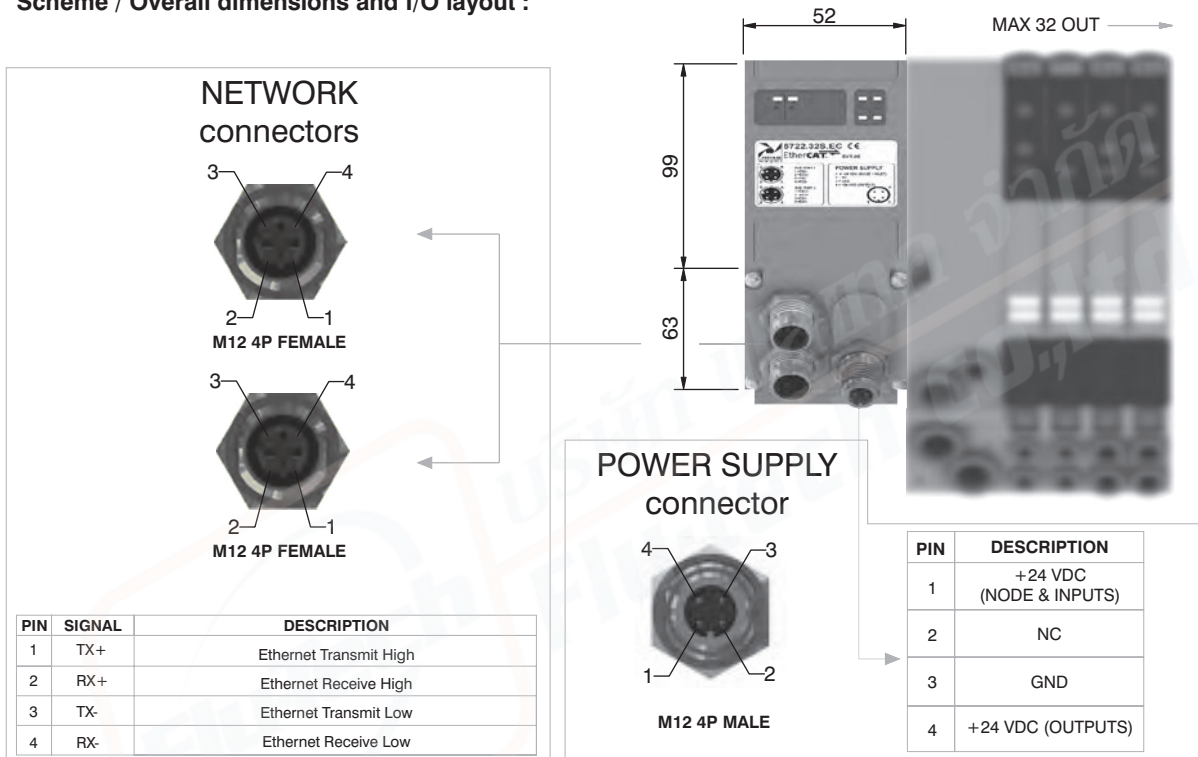

Technical characteristics

Model	5722.32S.EC	
Specifications	EtherCAT® Specifications ETG.1000 series	
Case	Reinforced technopolymer	
Power supply	Power supply connection	M12 4P male connector (IEC 60947-5-2)
	Power supply voltage	+24 VDC +/- 10%
	Node consumption (without inputs)	400 mA
	Power supply diagnosis	Green LED PWR / Green LED OUT
Outputs	PNP equivalent outputs	+24 VDC +/- 10%
	Maximum current for each output	100 mA
	Maximum output number	32
	Max output simultaneously actuated	32
Network	Network connectors	2 M12 4P female connectors Type D (IEC 61076-2-101)
	Baud rate	100 Mbit/s
	Addresses, possible numbers	From 1 to 65535
	Max nodes in net	65536 (Master + Slave)
	Maximum distance between 2 nodes	100 m
	Bus diagnosis	1 green and 1 red LED for status + 2 LEDs for link & activity
	Configuration file	Available from our web site: http://www.pneumaxspa.com
	IP protection grade	IP65 when assembled
	Temperature range	From 0° to +50° C

General:

PROFINET IO RT module is directly integrated on Optyma-S solenoid valves manifold via a 37 poles connector, normally used for multipolar cable connection. Optyma-S solenoid valves connected to node must be PNP equivalent (final 02 in ordering code).

The node can be easily installed also on solenoid valves manifold already mounted on equipment.

Module can manage up to 32 solenoid valves, and, in the same time, a max number of 4 Input modules 5222.08S.

The PROFINET IO RT module, regardless the number of Input module connected, reports to have connected 8 Input modules.

Regardless of the number of Input modules connected, the manageable solenoid valves are 32.

Node power supply is made by a M12 4P male circular connector.

The separation between node 24 VDC Power supply and outputs 24 VDC allows to switch off the outputs maintaining powered the node and inputs, if present.

Connection to Bus PROFINET IO RT is possible via 2 M12 4P type D female circular connectors. These two connectors lead the signal to two different communication ports, so they are not connected in parallel.

The node address is assigned during configuration.

Ordering code

5722.32S.PN



Scheme / Overall dimensions and I/O layout :

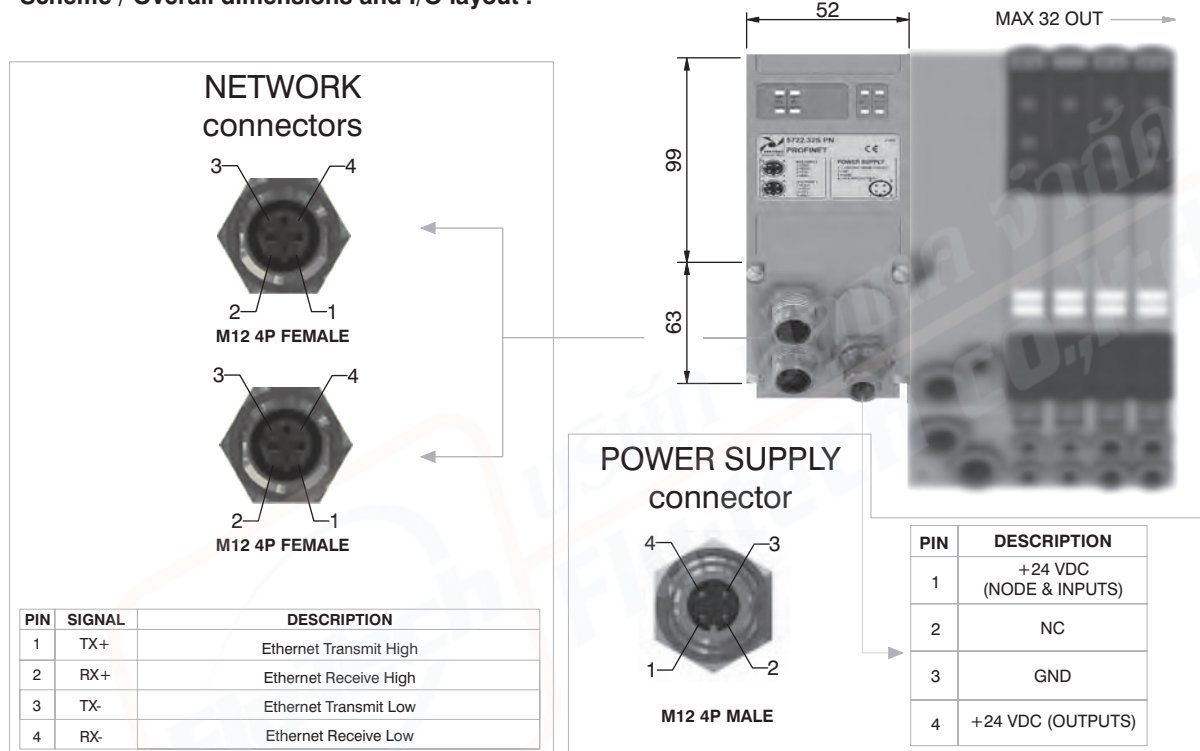

Technical characteristics

Model	5722.32S.PN
Specifications	PROFINET IO RT/IRT
Case	Reinforced technopolymer
Power supply	Power supply connection M12 4P male connector (IEC 60947-5-2)
	Power supply voltage +24 VDC +/- 10%
	Node consumption (without inputs) 400 mA
	Power supply diagnosis Green LED PWR / Green LED OUT
Outputs	PNP equivalent outputs +24 VDC +/- 10%
	Maximum current for each output 100 mA
	Maximum output number 32
	Max output simultaneously actuated 32
Network	Network connectors 2 M12 4P female connectors Type D (IEC 61076-2-101)
	Baud rate 100 Mbit/s
	Addresses, possible numbers As an IP address
	Max nodes in net As an Ethernet Network
	Maximum distance between 2 nodes 100 m
	Bus diagnosis 1 green and 1 red LED for status + 4 LEDs for link & activity
	Configuration file Available from our web site: http://www.pneumaxspa.com
	IP protection grade IP65 when assembled
	Temperature range From 0° to +50° C



General:

EtherNet/IP module is directly integrated on Optyima-S solenoid valves manifold via a 37 poles connector, normally used for multipolar cable connection.
Optyima-S solenoid valves connected to node must be PNP equivalent (final 02 in ordering code).

The node can be easily installed also on solenoid valves manifold already mounted on equipment.

Module can manage up to 32 solenoid valves, and, in the same time, a max number of 4 Input modules 5222.08S.

The EtherNet/IP module, regardless the number of Input module connected, reports to have connected 8 Input modules.

Regardless of the number of Input modules connected, the manageable solenoid valves are 32.

Node power supply is made by a M12 4P male circular connector.

The separation between node 24 VDC Power supply and outputs 24 VDC allows to switch off the outputs maintaining powered the node and inputs, if present.

Connection to Bus EtherNet/IP is possible via 2 M12 4P type D female circular connectors. These two connectors lead the signal to two different communication ports, so they are not connected in parallel.

The node address is assigned during configuration.

Ordering code

5722.32S.EI



1
AIR DISTRIBUTION

Scheme / Overall dimensions and I/O layout :

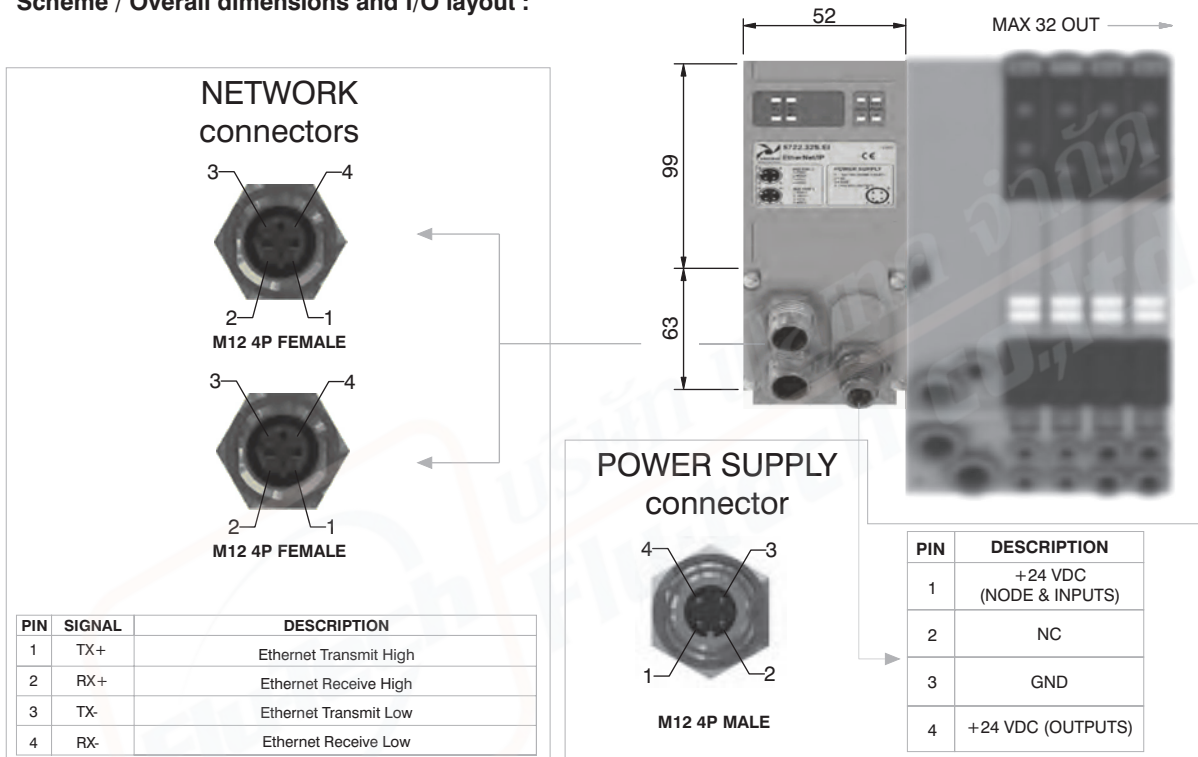

Technical characteristics

Model	5722.32S.EI
Specifications	The EtherNet/IP Specification
Case	Reinforced technopolymer
Power supply	Power supply connection M12 4P male connector (IEC 60947-5-2)
	Power supply voltage +24 VDC +/- 10%
	Node consumption (without inputs) 400 mA
	Power supply diagnosis Green LED PWR / Green LED OUT
Outputs	PNP equivalent outputs +24 VDC +/- 10%
	Maximum current for each output 100 mA
	Maximum output number 32
	Max output simultaneously actuated 32
Network	Network connectors 2 M12 4P female connectors Type D (IEC 61076-2-101)
	Baud rate 100 Mbit/s
	Addresses, possible numbers As an IP address
	Max nodes in net As an Ethernet Network
	Maximum distance between 2 nodes 100 m
	Bus diagnosis 1 green and 1 red LED for status + 4 LEDs for link & activity
	Configuration file Available from our web site: http://www.pneumaxspa.com
	IP protection grade IP65 when assembled
	Temperature range From 0° to +50° C

General:

Powerlink module is directly integrated on Optyma-S solenoid valves manifold via a 37 poles connector, normally used for multipolar cable connection. Optyma-S solenoid valves connected to node must be PNP equivalent (final 02 in ordering code).

The node can be easily installed also on solenoid valves manifold already mounted on equipment.

Module can manage up to 32 solenoid valves, and, in the same time, a max number of 4 Input modules 5222.08S.

The Powerlink module, regardless the number of Input module connected, reports to have connected 8 Input modules.

Regardless of the number of Input modules connected, the manageable solenoid valves are 32.

Node power supply is made by a M12 4P male circular connector.

The separation between node 24 VDC Power supply and outputs 24 VDC allows to switch off the outputs maintaining powered the node and inputs, if present.

Connection to Bus Powerlink is possible via 2 M12 4P type D female circular connectors. These two connectors lead the signal to two different communication ports, so they are not connected in parallel.

The node address is assigned during configuration.

Ordering code

5722.32S.PL



Scheme / Overall dimensions and I/O layout :

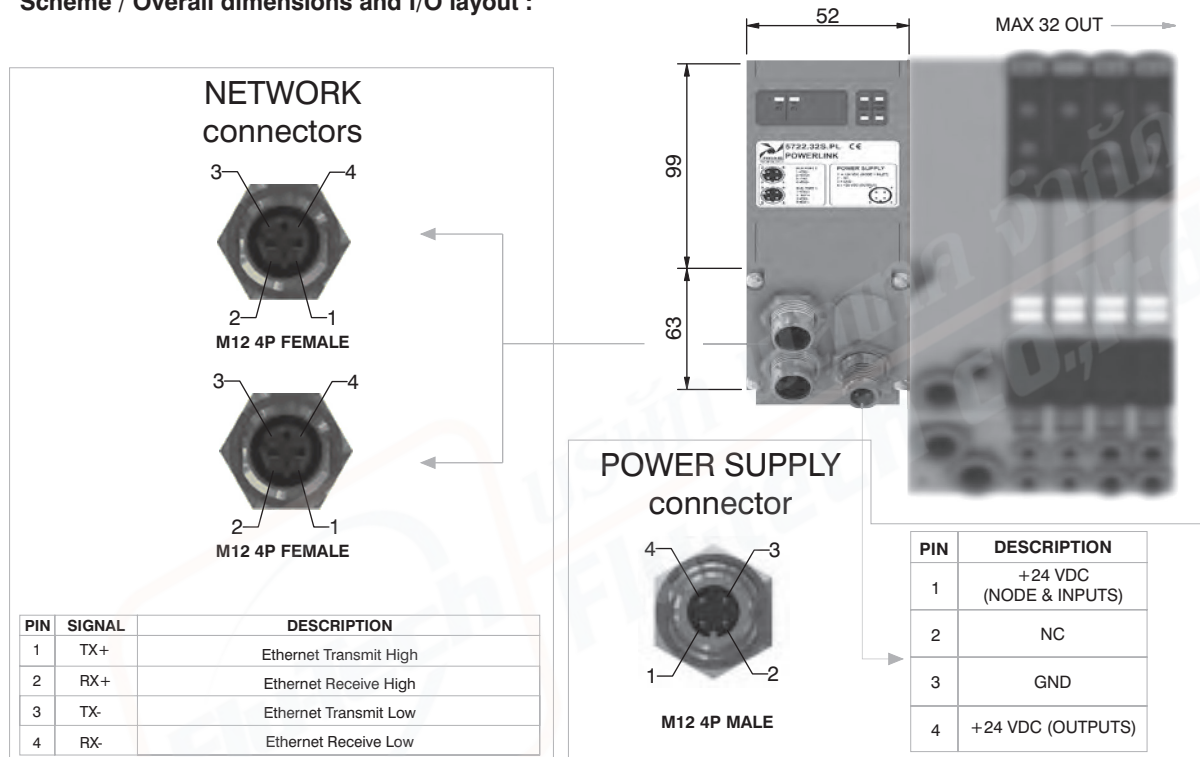

Technical characteristics

Model	5722.32S.PL	
Specifications	Ethernet POWERLINK Communication Profile Specifications	
Case	Reinforced technopolymer	
Power supply	Power supply connection	M12 4P male connector (IEC 60947-5-2)
	Power supply voltage	+24 VDC +/- 10%
	Node consumption (without inputs)	400 mA
	Power supply diagnosis	Green LED PWR / Green LED OUT
Outputs	PNP equivalent outputs	+24 VDC +/- 10%
	Maximum current for each output	100 mA
	Maximum output number	32
	Max output simultaneously actuated	32
Network	Network connectors	2 M12 4P female connectors Type D (IEC 61076-2-101)
	Baud rate	100 Mbit/s
	Addresses, possible numbers	239
	Max nodes in net	240
	Maximum distance between 2 nodes	100 m
	Bus diagnosis	1 green and 1 red LED for status + 2 LEDs for link & activity
	Configuration file	Available from our web site: http://www.pneumaxspa.com
	IP protection grade	IP65 when assembled
	Temperature range	From 0° to +50° C



General:

Modbus/TCP module is directly integrated on Optyima-S solenoid valves manifold via a 37 poles connector, normally used for multipolar cable connection.
 Optyima-S solenoid valves connected to node must be PNP equivalent (final 02 in ordering code).
 The node can be easily installed also on solenoid valves manifold already mounted on equipment.
 Module can manage up to 32 solenoid valves, and, in the same time, a max number of 4 Input modules 5222.08S.
 The Modbus/TCP module, regardless the number of Input module connected, reports to have connected 8 Input modules.
 Regardless of the number of Input modules connected, the manageable solenoid valves are 32.
 Node power supply is made by a M12 4P male circular connector.
 The separation between node 24 VDC Power supply and outputs 24 VDC allows to switch off the outputs maintaining powered the node and inputs, if present.
 Connection to Bus Modbus/TCP is possible via 2 M12 4P type D female circular connectors.
 These two connectors lead the signal to two different communication ports, so they are not connected in parallel.
 The node address is assigned during configuration.

Ordering code

5722.32S.MT



1
AIR DISTRIBUTION

Scheme / Overall dimensions and I/O layout :

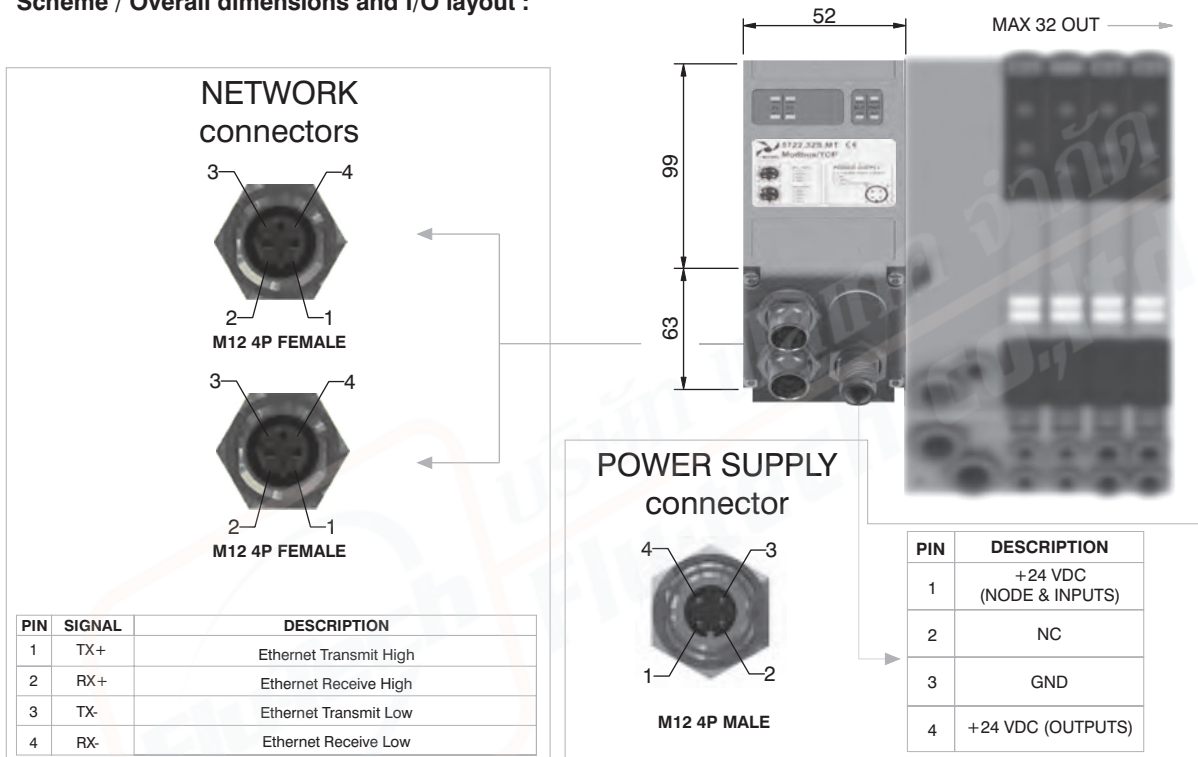

Technical characteristics

Model	5722.32S.MT
Specifications	MODBUS Application Protocol Specification V1.1a, June 4, 2004
Case	Reinforced technopolymer
Power supply	Power supply connection M12 4P male connector (IEC 60947-5-2)
	Power supply voltage +24 VDC +/- 10%
	Node consumption (without inputs) 400 mA
	Power supply diagnosis Green LED PWR / Green LED OUT
Outputs	PNP equivalent outputs +24 VDC +/- 10%
	Maximum current for each output 100 mA
	Maximum output number 32
	Max output simultaneously actuated 32
Network	Network connectors 2 M12 4P female connectors Type D (IEC 61076-2-101)
	Baud rate 100 Mbit/s
	Addresses, possible numbers 248
	Max nodes in net 248
	Maximum distance between 2 nodes 100 m
	Bus diagnosis 1 green and 1 red LED for status + 2 LEDs for link & activity
	Configuration file Modbus/TCP nodes don't require configuration file
	IP protection grade IP65 when assembled
	Temperature range From 0° to +50° C

General:

IO-Link module is directly integrated on Optyma-S solenoid valves manifold via a 37 poles connector, normally used for multipolar cable connection.
 Optyma-S solenoid valves connected to node must be PNP equivalent (final 02 in ordering code).
 The node can be easily installed also on solenoid valves manifold already mounted on equipment.
 Module can manage up to 32 solenoid valves, and, in the same time, a max number of 4 Input modules 5222.08S.
 Regardless of the number of Input modules connected, the manageable solenoid valves are 32.
 Valve power supply will be provided through an external M12, 5 poles, A type connector, directly through the communication connector for Class B port option.
 IO-Link module support the IO-Link communications speed COM2.
 IODD configuration files will be provided by Pneumax.

Ordering code

5822.32S



Scheme / Overall dimensions and I/O layout :

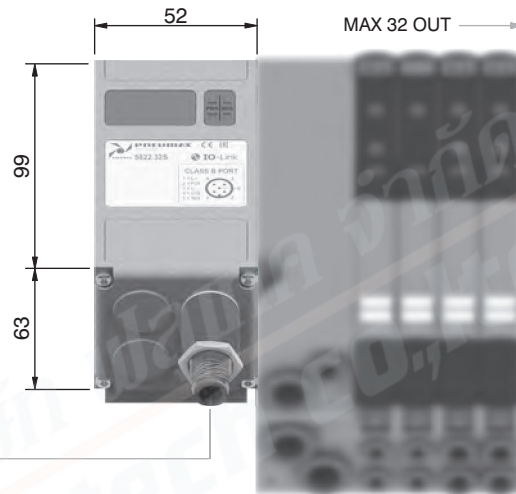
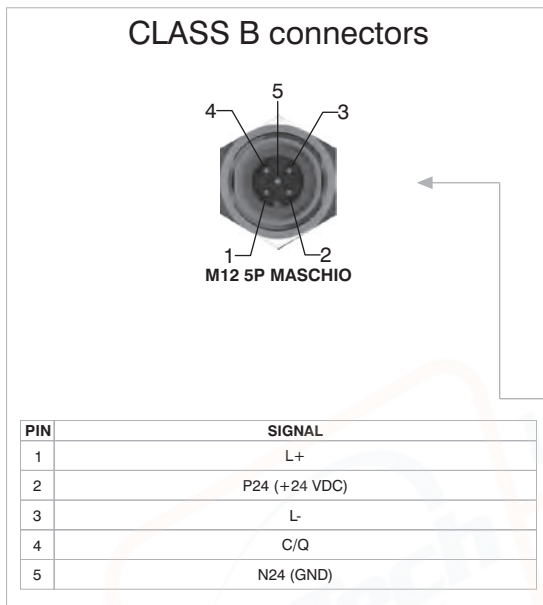

Technical characteristics

	Specifications	IO-Link Specification v1.1
	Case	Reinforced technopolymer
Outputs	PNP equivalent outputs	+24 VDC +/- 10%
	Maximum current for each output	100 mA
	Maximum output number	32
	Max output simultaneously actuated	32
Network	Network connectors	Class B ports
	Communication speed	COM 2
	Maximum distance from Master	20 m
	Bus diagnosis	1 green and 1 red LED for status
	Configuration file IODD	Available from our web site: http://www.pneumaxspa.com
	IP protection grade	IP65 when assembled
	Temperature range	From 0° to +50° C



General:

Modules have 8 connectors M8 3P female.

The Inputs are PNP equivalent 24 VDC ± 10%.

To each connector it is possible to plug both 2 wires Inputs (switches, magnetic switches pressure switches, etc) or 3 wires Inputs (proximity, photocells, electronic sensors, etc).

The maximum current available for all 8 Inputs is 300 mA.

Each module includes a 300 mA self-mending fuse. If a short circuit or a overcharge (overall current >300mA) occur the safety device acts cutting the 24 VDC power supply to all M8 connectors on the module and switching off the green LED PWR. Any other Input module connected to the node will remain powered and will function correctly.

Once the cause of the fault disappears the green LED PWR lights up indicating the ON state and the node will re-start to operate.

The maximum number of Input modules supported is 4.

Ordering code

5222.08S



Scheme / Overall dimensions and I/O layout :

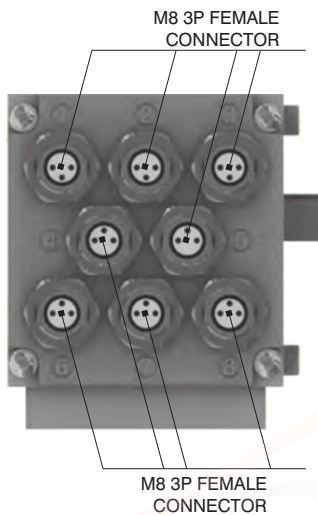

PIN	DESCRIPTION
1	+24 VDC
4	INPUT
3	GND

Module 1



Module 2 Module 1

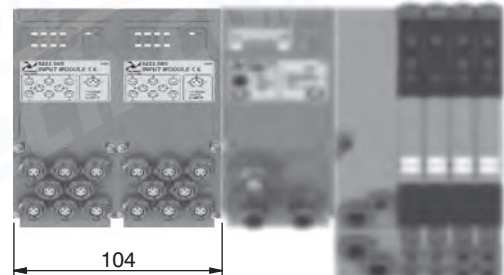

Module 3 Module 2 Module 1

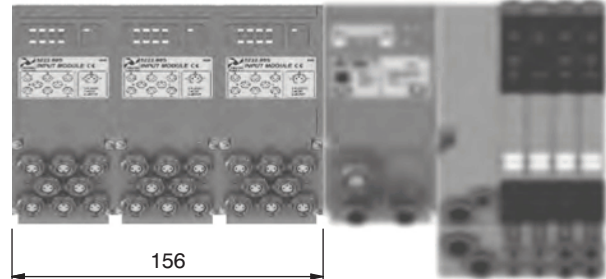

Module 4 Module 3 Module 2 Module 1

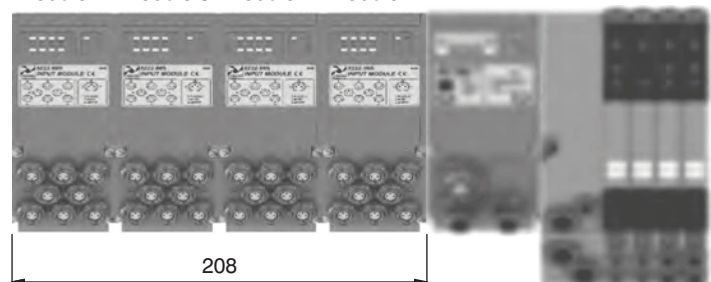

Socket for Power Supply
STRAIGHT CONNECTOR
M12A 4P FEMALE

Ordering code

5312A.F04.00



POWER SUPPLY connector

Upper view
Slave connector

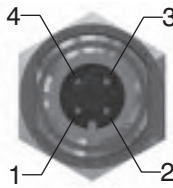

PIN	DESCRIPTION
1	+24 VDC Node
2	
3	0 V
4	+24 VDC Outputs

Socket for Bus CANopen®/DeviceNet
STRAIGHT CONNECTOR
M12A 5P FEMALE

Ordering code

5312A.F05.00

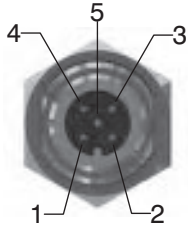

Upper view
Slave connector

PIN	DESCRIPTION
1	(CAN_SHIELD)
2	(CAN_V+)
3	CAN_GND
4	CAN_H
5	CAN_L

NETWORK connectors

Plug for Bus CANopen®/DeviceNet
STRAIGHT CONNECTOR
M12A 5P MALE

Ordering code

5312A.M05.00

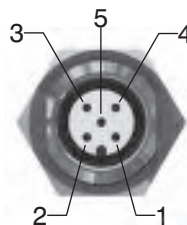

Plug for Bus EtherCAT®,
PROFINET IO RT,
EtherNet/IP and Powerlink
STRAIGHT CONNECTOR M12D 4P MALE

Ordering code

5312D.M04.00



PIN	SIGNAL	DESCRIPTION
1	TX+	Ethernet Transmit High
2	RX+	Ethernet Receive High
3	TX-	Ethernet Transmit Low
4	RX-	Ethernet Receive Low

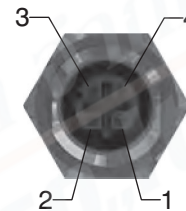

Upper view
Slave connector

Socket for Bus PROFIBUS DP
STRAIGHT CONNECTOR
M12B 5P FEMALE

Ordering code

5312B.F05.00

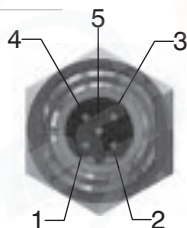

Upper view
Slave connector

PIN	DESCRIPTION
1	Power Supply
2	A-line
3	DGND
4	B-line
5	SHIELD

Plug for Bus PROFIBUS DP
STRAIGHT CONNECTOR
M12B 5P MALE

Ordering code

5312B.M05.00

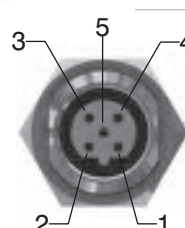

Upper view
Slave connector

Plug for Input module
STRAIGHT CONNECTOR
M8 3P MALE

Ordering code

5308A.M03.00

INPUT connectors

Upper view
Slave connector

PIN	DESCRIPTION
1	+24 VDC
4	INPUT
3	GND

M12 plug

Ordering code

5300.T12



Plugs

M8 plug

Ordering code

5300.T08

