



WWW.FLUTECH.CO.TH



LINE ADD FRIEND @flutech.co.th

Authorized Distributor



บริษัท ฟลูเทค จำกัด
Flu-tech co.,ltd

Air Hammer & Pneumatic Vibrator

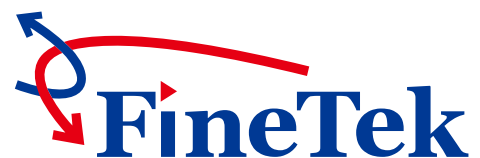

Innovation · Quality · Sharing

APPLICATION

INTRODUCTION

In automatic factories, there are different piping systems, conveyors, weighing arrangements, life testing equipments, and dust collectors for production process.

Material characteristic (moisture, S.G., size..) and equipment design (shape, layout...) are usually the causes of medium accumulation in the pipes and tanks.

By applying pneumatic vibrators in the problem area, it will provide the best solution. Pneumatic vibrators will shake off the clogged or attached material and eliminate friction during automatic production.

WORKING PRINCIPLE

Vibration is created by the high centrifugal force of the circulating steel roller, which runs on a steel ring at very high frequency.

MERIT OF VIBRATORS

The body of pneumatic vibrator is made of strengthened aluminum alloy. It is simple structured small size vibrator with strong vibrating force. The vibrator is responsive for sudden activation / deactivation, which eliminates the damage of the equipments to the minimum level.

The vibrator is forced by compressed air. It is easily operated without spark. The working principle does not cause sparks, which can be applied in hazardous, humid or other severe environment. Power force, frequency and amplitude can be adjusted while operating.

MODERATE TYPE

| Model | Air hammer | Piston vibrator | | Pneumatic vibrator | | |
|------------------------------|------------|--------------------|---------------------|--------------------|------------|-------------|
| | BAH | BVP10000-01 Strike | BVP10000-00 Cushion | BVK BALL | BVR ROLLER | BVT TURBINE |
| Get rid of blockage | | | | | | |
| Pipe accumulation | | | | | | |
| Derust piping | | | | | | |
| Vibrating delivery sieving | | | | | | |
| Arrangement & Conveyance | | | | | | |
| Filling & Packing | | | | | | |
| Defoaming while filling | | | | | | |
| Concrete injection | | | | | | |
| Sand compacted while molding | | | | | | |
| Static electricity coating | | | | | | |
| Life testing | | | | | | |

 Excellent
  Fair

BVP SERIES PISTON VIBRATOR (IMPACT MODEL)

FEATURES

1. Highly strengthened aluminum body.
2. Low frequency/ continuous impact model, sudden activation/ deactivation.
3. Frequency and amplitude of impact can be adjusted as required.
4. Direct impact onto target object to produce the optimum vibration feedback.

Direct impact of piston impact type can get rid of rust and material attachment inside the pipes, and low S.G, high moisture material, and material built-up in the tank.

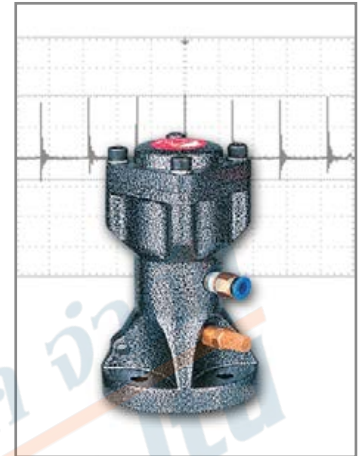

Temperature: -40~100°C
Noise level range: 80-115 dBA

WORKING PRINCIPLE

There are air-breathing tubes located in both end side of cylinder. Air will be compressed in to push piston from one side to the other side. Vibration is arose by the back and forth movement of the piston in the body. Air cushion at top end will keep piston away from striking onto the body. On the other hand, piston will strike directly on the bottom of the body to produce strong impact.

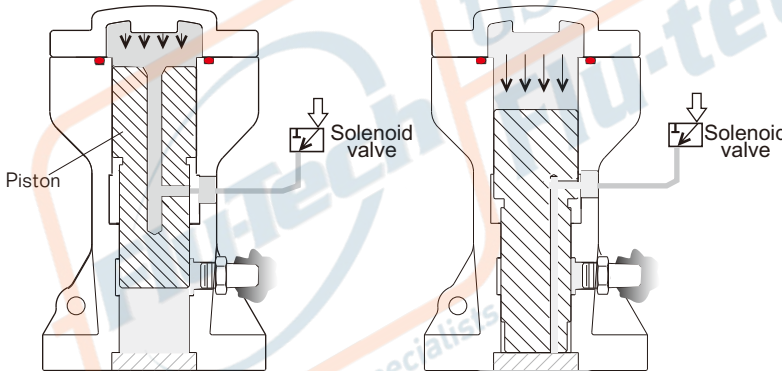

- (1) Compressed air via top air-breathing tube pushes piston moving downward. Air in the bottom will be exhausted via outlet hole.
- (2) Compressed air via down air-breathing tube pushes piston moving upward. The movement repeats from step (1)

NEW/OLD MODEL NO. COMPARISON TABLE

| Old Model No. | New Model No. |
|---------------|---------------|
| BVP-30S | BVP10000-0130 |
| BVP-40S | BVP10000-0140 |
| BVP-60S | BVP10000-0160 |

| Model No. | A | ϕB | ϕC | D | ϕH | IN | OUT |
|---------------|-----|----------|----------|----|----------|---------|---------|
| BVP10000-0130 | 138 | 80 | 60 | 12 | 9 | 1/8" PF | 1/8" PF |
| BVP10000-0140 | 166 | 100 | 75 | 16 | 11 | 1/4" PF | 1/4" PF |
| BVP10000-0160 | 208 | 140 | 105 | 16 | 15 | 1/4" PF | 1/4" PF |

Unit= mm

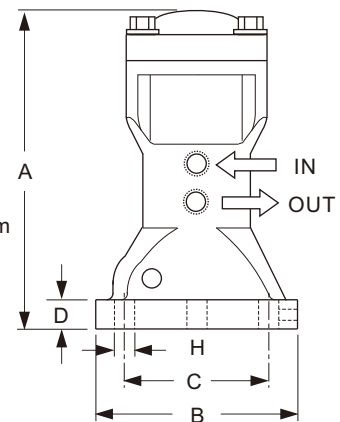

| Model No. | FREQUENCY (V.P.M.) | | | FORCE (N) | | | AIR CONSUMPTION (ℓ / min) | WEIGHT (g) |
|---------------|----------------------|---------------------|---------------------|---------------------|---------------------|---------------------|----------------------------------|------------|
| | 2kg/cm ² | 4kg/cm ² | 6kg/cm ² | 2kg/cm ² | 4kg/cm ² | 6kg/cm ² | | |
| BVP10000-0130 | 1900 | 2800 | 3500 | 3600 | 5400 | 6200 | 250 | 1.0 kg |
| BVP10000-0140 | 1700 | 2400 | 3000 | 6450 | 8750 | 9400 | 270 | 2.1 kg |
| BVP10000-0160 | 1200 | 1800 | 1900 | 6900 | 12850 | 13850 | 300 | 4.8 kg |

ACCUMULATED MATERIAL SOLUTION

Different applications require various tanks. Customers choose appropriate vibrators to meet application demand (tank shape/ material, applied material humidity/ S.G./ granule size...). Suitable vibrator will not only prevent obstruction problem but also avoid the damage of tank wall.

Big amplitude, low frequency piston types are suitable in granule with small S.G. . AB1/AB2/AB3 types are better choices for high S.G. or material accumulation in filtration environment. It is recommended to use multiple vibrators in serious clogging situation or big tank surrounding.

Accumulation condition and vibrator installation

According to various clogging situations, the recommended vibrators and suitable installation positions (usually 1/2L or 1/3L) are shown by below.

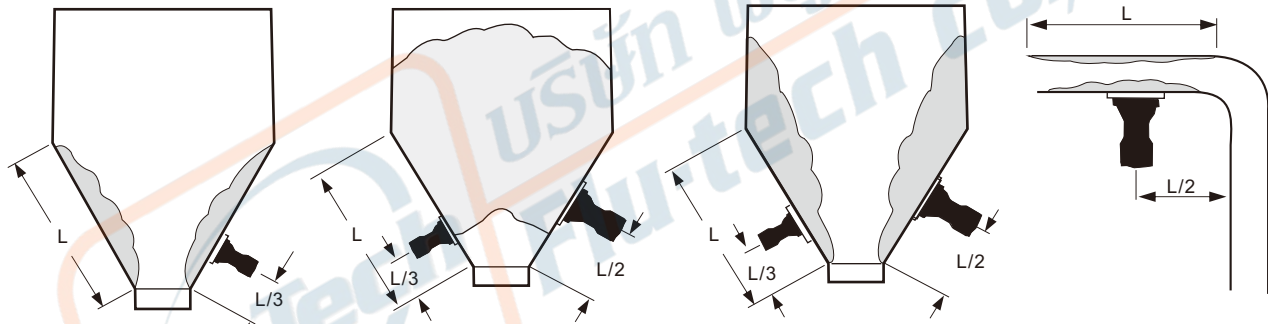

Vibration force calculation

Taking accumulation situation into consideration, appropriate vibrator will give 0.2~0.4 G accelerated vibration force onto target object.

$F=0.2\sim 0.4GW$,
 F: Vibration force (N)
 G: $9.8m/s^2$
 W: Material weight (KG)

EX: Cone tank, R=3.5m, r=2.5m, Tank height H=2m, material S.G.=0.8, please calculate the vibration needed for this tank.

Sol: Get volume of material first (please refer to fig. on the right for formula) .
 Material Weight (W)=volume(V)*specific gravity(S.G)
 Vibration $F=0.2 GW$ ($G=9.8m/s^2$, W=material weight)

Material weight calculation

Cone volume $V= 3.14*2/3(3.5*3.5+3.5*0.5+0.25*0.5)=29.83(m^3)$
 Material Weight $W= 29.83*0.8=23.86=23680(kg)$
 Vibration $F= 0.2*23860*9.8=46765$ Newton Force(N)

W: Material weight (KG)
 V: Chute volume (m^3)
 γ : Specific gravity

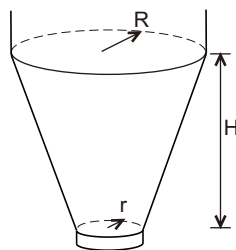

$W=1000V\gamma$ $V= \frac{\pi H}{3} (R^2+Rr+r^2)$

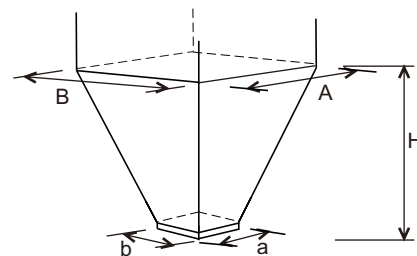

$V= \frac{H}{6} [A \times B+(A+a)(B+b)+a \times b]$

INSTALLATION

Vibration force transmits more efficiently in conical hopper tank than in rectangular hopper. It is recommended to install two vibrators for rectangular hopper application.

1. Vibration force can be transmitted more efficiently by using U shape steel supporter. It can help material fall smoothly in the tank or pipe. It also reduces tank damage.
2. U shape steel or fixer can prevent irregular movement of vibrators. To avoid possible damage on the tank wall caused by vibration force, stitch weld method is suggested. (10mm space will be required on two ends of U shape steel)
3. Reinforced board is required between U shape steel and thin tank wall.
4. Cross installed of U shape steel can increase vibration field in big hopper tank.

ATTENTION

Vibrator has to be fixed by high tension bolt, washer, and spring washer. It is suggested to use security cable if vibrator is installed onto hopper.

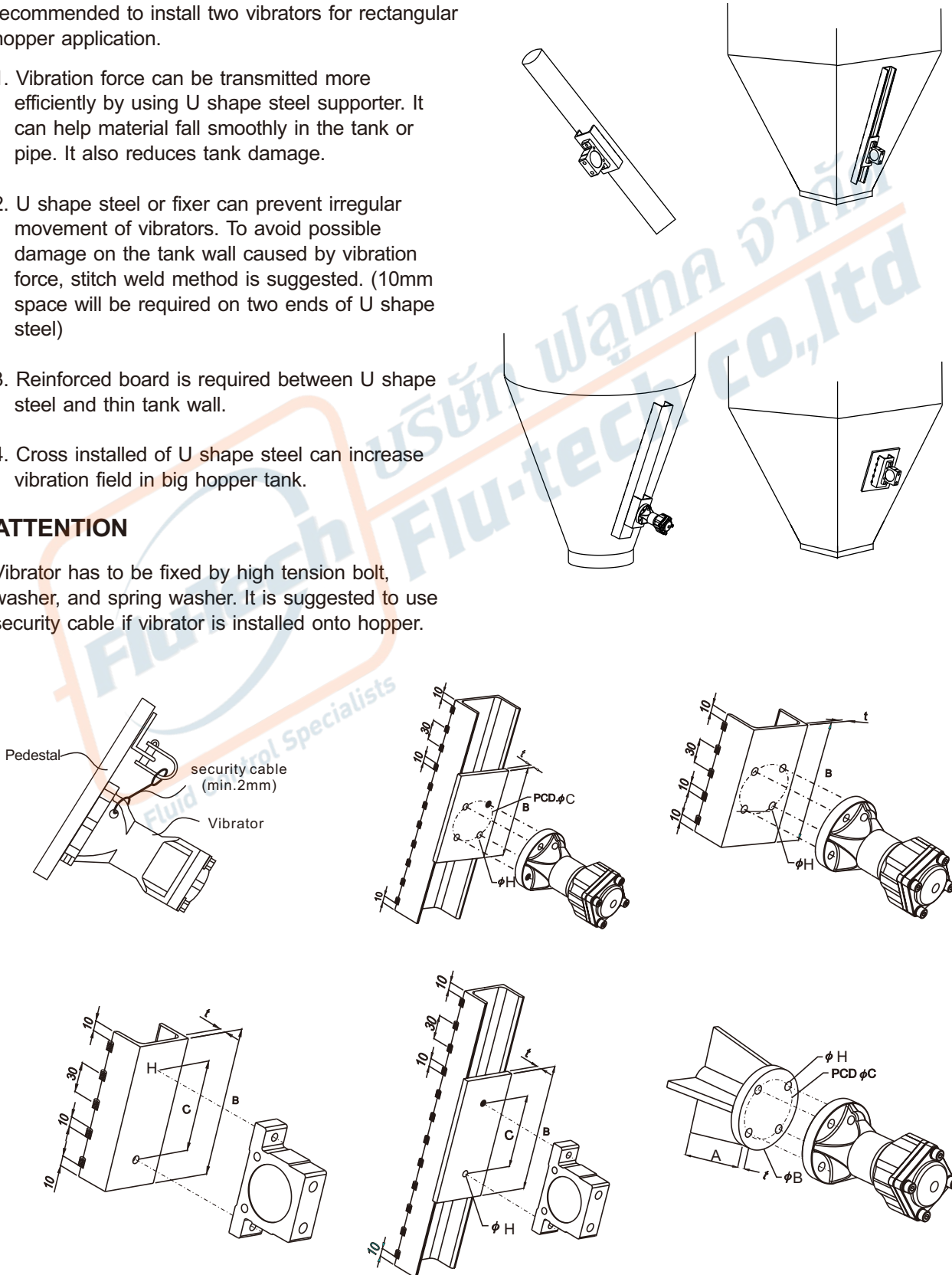

AIR SUPPLY AND LUBRICATION

AIR SUPPLY

The moisture in the compressed air will erode pipes and accessories, then weaken the vibrator's performance. Make sure necessary steps are followed before applying. To fully utilize vibrator performance, choose appropriate product for different application.

LUBRICATION

All vibrators require lubricating oil to smooth the operation. Low viscosity oil will be injected into cup of F.R.L. combination unit to adjust required spread oil amount. To aim at specific application requirement, muffler can be applied onto exhaust tube in outside area to prevent food from pollution. Or to inject 2~3 drops of edible oil via air inlet sometimes is an alternative choice. BAH series don't need lubrication unless they are running frequently.

TUBING ARRANGEMENT

Muffler can reduce noise and prevent dust enter the vibrator. The size of tubing should meet with that of vibration air inlet/ exhaust. In the meantime, as two vibrators work simultaneously, length of tubing should be equal after separation. In the meantime, the cross section of tubing should be twice of the vibrator.

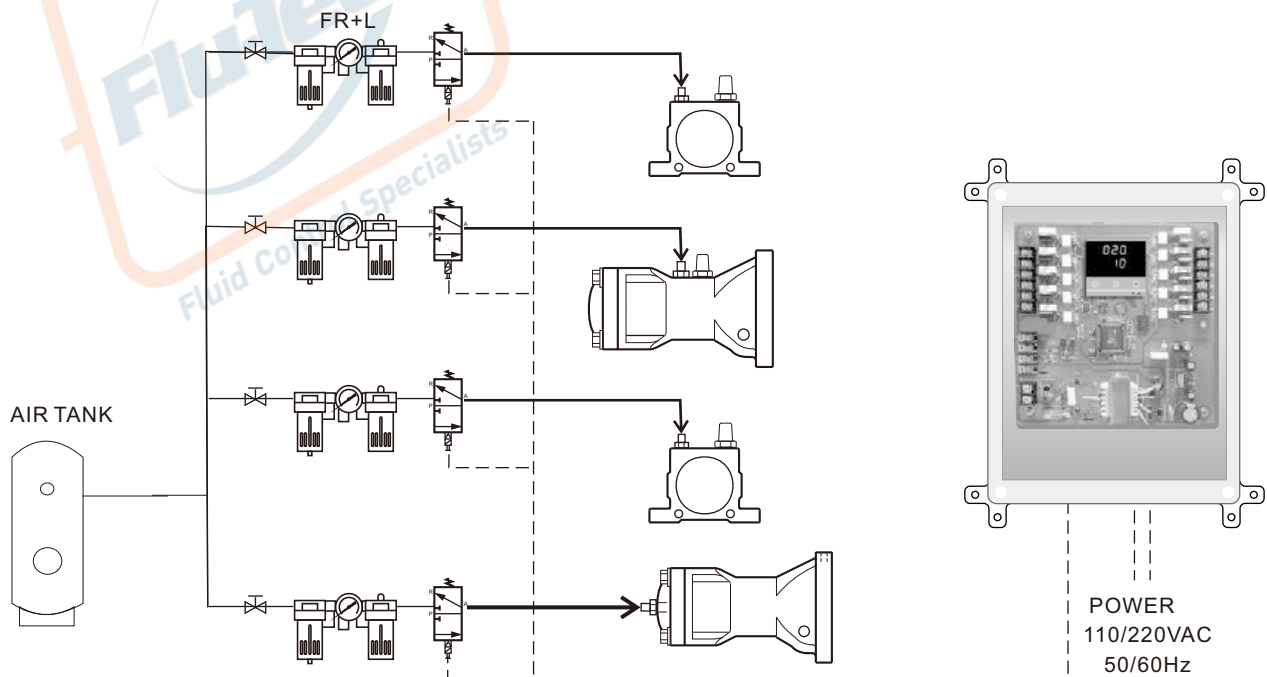

VIBRATOR ACCESSORIES

MUFFLER

Muffler is an accessory that decreases noise when air is exhausted from vibrator.

MUFFLER
Material: Plastic



| Type | Model | HP411-AIR006A102 | HP411-AIR006A202 | HP411-AIR006A402 |
|------------------------------|-----------------|------------------------------------|------------------|------------------|
| Range of service pressure | | 0~9(900) kgf/cm ² (kpa) | | |
| Range of service temperature | | 5~60°C | | |
| Material | Body | BRASS | | |
| | Filter Element | BRASS (60mm) | | |
| Orifice | mm ² | 17 | 42 | 50 |
| Noise elimination effect | dB | 1 | 6 | 13 |
| Connection port | (PT) | 1/8" | 1/4" | 3/8" |

1/8": HP411-AIR006A101
1/4": HP411-AIR006A201
3/8": HP411-AIR006A401

F.R.L COMBINATION (OPTION PART)



| Model | Port Size | Lubricator | Regulator | Bracket | Suitable Type | | | | |
|------------------|-----------|------------|-----------|---------|----------------|-------|----------------|-------------|-------------|
| | | | | | BVK | BVR | BVT | BVP | BAH |
| HP411-AIR008A202 | 1/4" | ✓ | ✓ | ✓ | 10 | 50 | 10 | | 30 |
| HP411-AIR008A201 | 1/4" | ✓ | ✓ | ✓ | 13 16 20 25 | 65 80 | 13 16 20 25 | 30 40 60 | 40 60 80 |
| HP411-AIR008A401 | 3/8" | ✓ | ✓ | ✓ | 32 | 100 | 32 | | |

QUICK JOINT (OPTION PART)



| Model | Pu Tube Size | Thread Size |
|------------------|--------------|-------------|
| HP411-AIR001A202 | OD6xID4 | PT 1/4" |
| HP411-AIR001A201 | OD8xID5 | PT 1/4" |
| HP411-AIR001A402 | OD12xID8 | PT 3/8" |

NEW/OLD MODEL NO. COMPARISON TABLE

| Old Model No. | New Model No. |
|---------------|------------------|
| 26-4000 | HP411-AIR006A102 |
| 26-4001 | HP411-AIR006A202 |
| 26-4002 | HP411-AIR006A402 |
| AFC-200 | HP411-AIR008A202 |
| BFC-200 | HP411-AIR008A201 |
| BFC-300 | HP411-AIR008A401 |
| SQC 6-02 | HP411-AIR001A202 |
| SQC 8-02 | HP411-AIR001A201 |
| SQC12-03 | HP411-AIR001A402 |
| SV-6102TB | MP509-1EA1300001 |
| SV-8103 | MP509-1EA2300002 |

SOLENOID VALVE (OPTION PART)



| Item | Model | MP509-1EA1300001 | MP509-1EA2300002 |
|------------------------------|-------|-------------------------------|------------------------------|
| Fluid | | Air | |
| Pressure Range | | 1~7Kgf/cm(100~700Kpa) | |
| Range Of Service Temperature | | 0~60°C | |
| Operating Method | | Pilot Operate | |
| Number Of Positions / Ports | | 2/3 | 2/5 |
| Valve Functions | | Normal Closed | |
| Orifice | | 14(0.78) mm ² (CV) | 18(1.0) mm ² (CV) |
| Manual Button | | Push And Lock | |
| Connections Port | | RT1/4 | PT3/8 |
| Lubrication | | Lubrication Free Type | |

MP509-1EA1300001

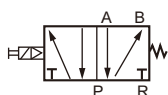

MP509-1EA2300002

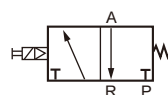

TROUBLE SHOOTING

Air vibrators are simply structured, which seldom breaks down. Break-down usually arose because of careless installation methods.

Pay attention to F.R.L. combination unit after long time operation.

| Trouble shooting | Possible factor | Solution |
|------------------------------------|---|---|
| Vibrator cannot run when switch on | No air supply, or low air supply pressure | To check pressure gauge in F.R.L. Unit and air compressor, the air pressure should be adjusted to exceed 5 kg/cm ² value. Make Sure to turn on the air supply valve and compressor |
| | Solenoid valve not activated. | To strip air plug of vibrator away, make sure whether air exhaust after solenoid valve is activated |
| | Exhaust plug of vibrator not being removed | To remove plastic plug of vibrator |
| | Installation mistake in AC1 series air inlet hole | To make sure air in/outlet installation position is correct. |
| | HAH can't be operated well due to inappropriate soleuoid valve. | Soleuoid valve has to be 3/2 ways type, otherwise BAH will not be able to exhaust after operating. |
| Too small vibration force | Install manifold or too many branches on main tube with same cross section size | To enlarge cross section of main tube equal or bigger than sum of manifold or branches tubes. or to install tubings individually |
| | Insufficient air supply, Inappropriate tube, solenoid valve, F.R.L unit , or tubing is too long | To make sure applied accessories match to required ones, the length of tubing should not go beyond 5M. |
| | Wrong VT exhaust and inlet installation | To check pressure of F.R.L. unit and adjust its value higher |
| | Articles are absorbed by the vibrator | To dismantle the vibrator for checking |
| | Objects jam in muffler | To check pressure of air supply and adjust it stronger |
| Vibration noise | Screw loosen | To tight the screws |
| | U shape steel is not welded well | To weld again |
| | Vibrators problem | To remove vibrator, then activate it individually. It has to be repaired, if abnormal condition happened while running. |
| Solenoid valve noise | Articles are in solenoid valve | To replace solenoid valve |

