

Series HMU Mini cylinders, double acting

Technical details

Operating pressure	1 ... 10 bar								
Temperature range	-20°C ... +80°C								
Max. stroke	900 mm								
Medium	Filtered, oil-free and dried compressed air according to ISO 8573-1:2010, Class 7:2:4, instrument air, free of aggressive additives. Alternatively the pressure dew point must be at least 10°C below lowest occurring ambient temperature.								
Materials	<table border="0"> <tr> <td>Cylinder tube:</td> <td>stainless steel</td> </tr> <tr> <td>End caps:</td> <td>Al (anodized)</td> </tr> <tr> <td>Piston rod:</td> <td>stainless steel</td> </tr> <tr> <td>Seals:</td> <td>PU, NBR</td> </tr> </table>	Cylinder tube:	stainless steel	End caps:	Al (anodized)	Piston rod:	stainless steel	Seals:	PU, NBR
Cylinder tube:	stainless steel								
End caps:	Al (anodized)								
Piston rod:	stainless steel								
Seals:	PU, NBR								



Double acting pneumatic cylinder with magnetic piston and built-in cushioning rings or adjustable cushions.

Versions

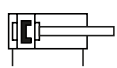

HMU
double acting, with magnetic piston

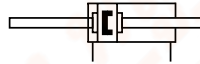

HMUDE
double acting, double end piston rod, with magnetic piston

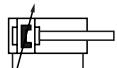

HMUP
double acting, adjustable cushioning, with magnetic piston

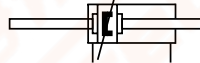

HMUPDE
double acting, double end piston rod, adjustable cushioning, with magnetic piston

Order code

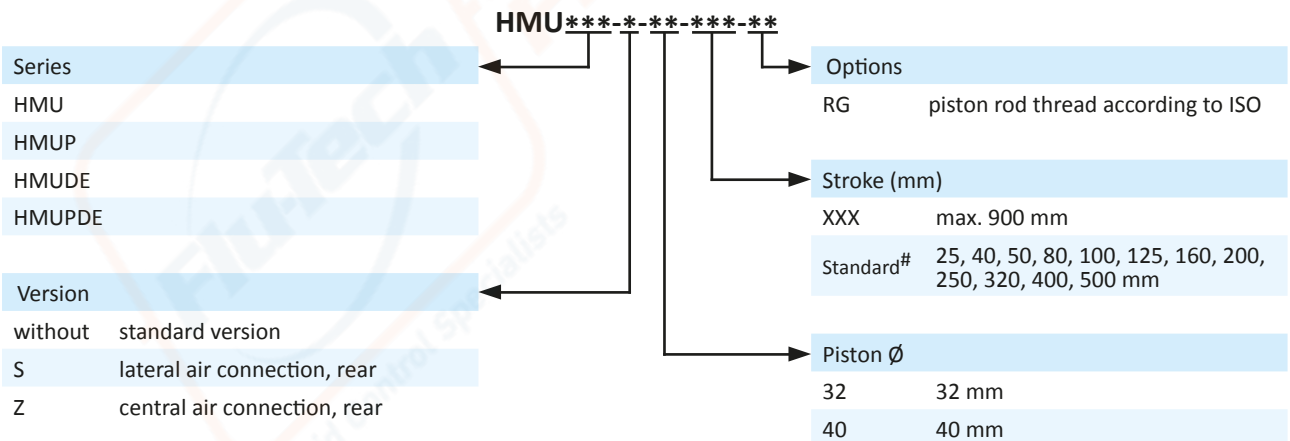

only for series HMU and HMUP

Series HMU

Mini cylinders, double acting

Technical data

Model-no.:	HMU-32-...	HMU-40-...	HMUP-32-...	HMUP-40-...
Piston \varnothing (mm)	32	40	32	40
Force at 6 bar (N)	Extension	678	434	678
	Retraction	570	373	570
Connection	G1/8	G1/4	G1/8	G1/4
Piston rod thread	M10 x 1.25	M12 x 1.25	M10 x 1.25	M12 x 1.25
Cushioning length (mm)	-	-	22.5	24.5

Dimensions series HMU, HMUP

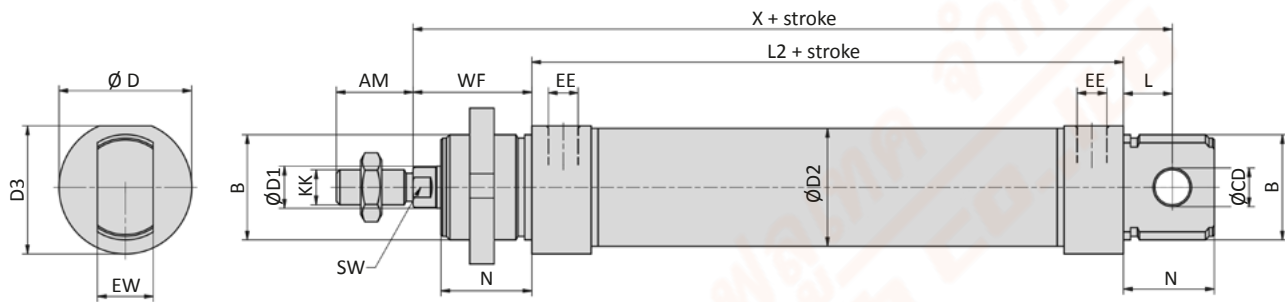

double end piston rod

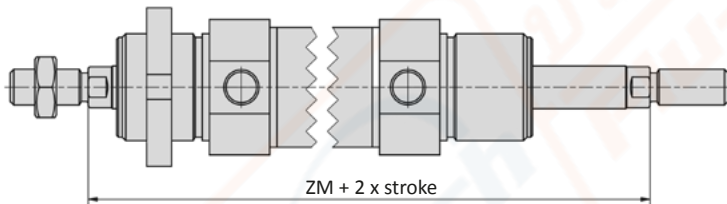

Version -Z

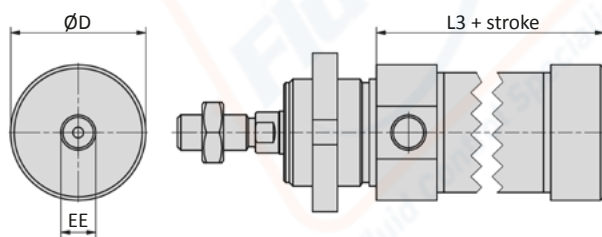

Version -S

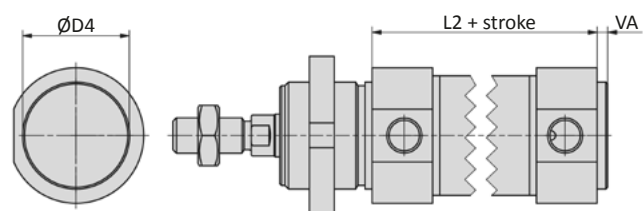

Piston \varnothing	AM	B	\varnothing CD	\varnothing D	\varnothing D1	\varnothing D2	D3	\varnothing D4	EE	EW
32	22	M30 x 1.5	10	38	12	33.6	36.5	30	G1/8	16
40	24	M38 x 1.5	12	46	16	41.6	44	38	G1/4	18

Piston \varnothing	KK	L	L2	L3	N	SW	VA	WF	X	ZM
32	M10 x 1.25	14	69.5	65.5	26	10	3	34	117.5	137.5
40	M12 x 1.25	16	84.5	77.5	30	13	4	39	139.5	162.5

RA-xx Foot mount

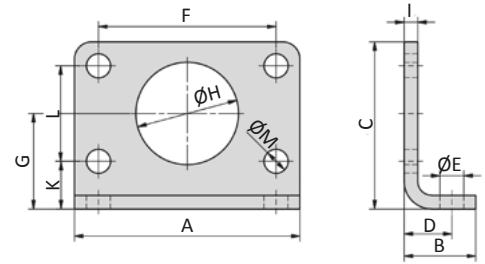
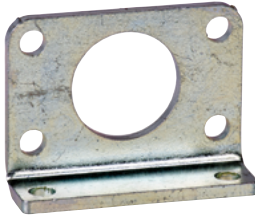

Model-no.:	A	B	C	D	Ø E	F	G	Ø H	I	K	L	Ø M
RA-32	66	21	49	14	7	52	28	30	4	14	28	7
RA-40	80	30	58	20	9	60	33	38	5	18	30	9

Material: steel, zinc plated

RC-xx-1 Clevis mount

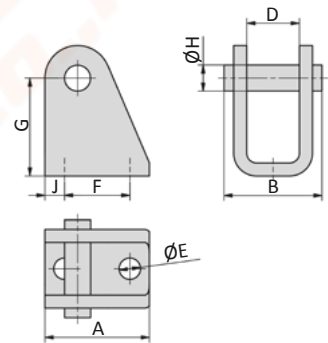

Model-no.:	A	B	D	Ø E	F	G	Ø H	J
RC-32-1	35	31.3	16.1	6.6	24	35	10	5.5
RC-40-1	45	35.5	18.1	9	30	40	12	7.5

Material: steel, zinc plated, 2 snap rings are included.

RD-xx, FD-xx Rod clevis

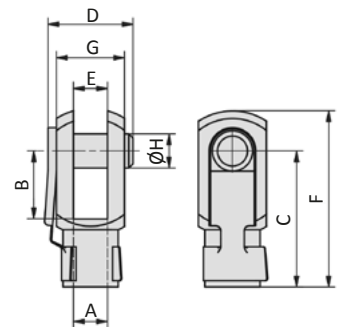

Model-no.:	A	B	C	D	E	F	G	Ø H
RD-25	M10 x 1.25	20	40	26	10	52	20	10
FD-40	M12 x 1.25	24	48	32	12	62	24	12

Material: steel, zinc plated

Series HMU Mounting accessories

FK-xx Flexible coupling

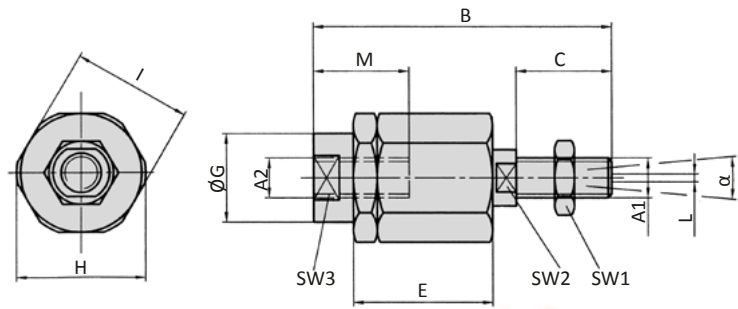

Model-no.:	A1, A2	B	C	D	E	ØG	H	I	L	M	SW1	SW2	SW3	α
FK-32	M10 x 1.25	71.5	20	7.5	35	22	32	30	2	22	17	12	19	8°
FK-40	M12 x 1.25	71.5	20	7.5	35	22	32	30	2	22	19	12	19	8°

Material: steel, zinc plated

RO-xx, FO-xx Rod eye

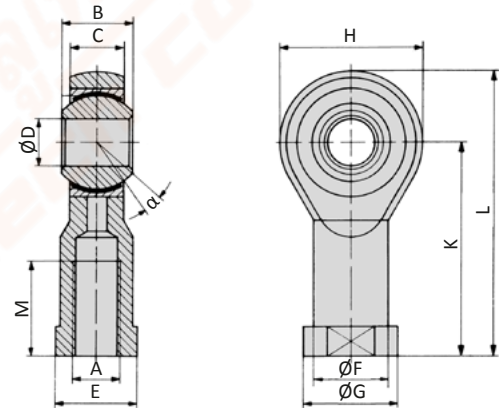

Model-no.:	A	B	C	ØD	E	ØF	ØG	H	K	L	M	α
RO-25	M10 x 1.25	14	10.5	10	17	15	19	28	43	57	20	13°
FO-40	M12 x 1.25	16	12	12	19	17.5	22	32	50	66	22	13°

Materials: steel, zinc plated, bearing steel, bronze bushing

Proximity sensors

