

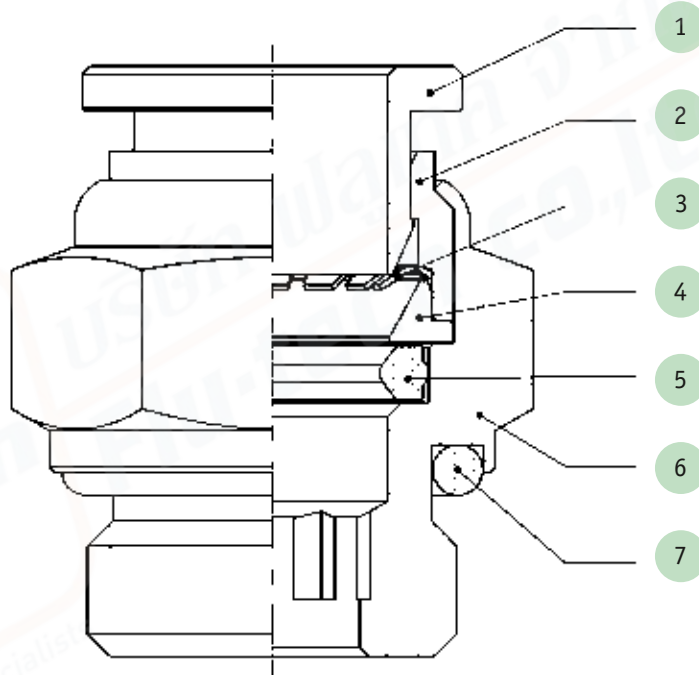

INOX SS

- 1 ANELLO SPINGITORE
THRUST SLEEVE
- 2 DISTANZIALE DI FERMO
LOCK RING
- 3 PINZA DI AGGRAFFAGGIO
CRIMPING GRIPPER
- 4 ANELLO DI SOSTEGNO
SUPPORTING RING
- 5 GUARNIZIONE DI TENUTA
SEAL PACKING
- 6 CORPO DEL RACCORDO
FITTING BODY
- 7 O-RING DI TENUTA
O-RING SEAL



ART. SSC-G

Diritto filetto a maschio
Straight male parallel adaptor

CODICE	ØD	G	L1	L2	⊙	🔑	🏠
SSC04-M5	4	M5	4	19,3	2	10	10
SSC04-G01	4	1/8	5,5	17,3	3	13	10
SSC04-G02	4	1/4	6,5	21,2	3	17	10
SSC06-M5	6	M5	4	20,6	2	12	10
SSC06-G01	6	1/8	5,5	18,8	4	13	10
SSC06-G02	6	1/4	6,5	18,8	4	16	10
SSC08-G01	8	1/8	5,5	23,2	5	14	10
SSC08-G02	8	1/4	6,5	20,7	6	16	10
SSC08-G03	8	3/8	7,5	22,5	6	21	10
SSC10-G02	10	1/4	6,5	26,4	8	17	10
SSC10-G03	10	3/8	7,5	22,9	8	20	5
SSC10-G04	10	1/2	9,0	24	8	24	5
SSC12-G02	12	1/4	6,5	31,3	8	21	5
SSC12-G03	12	3/8	7,5	25,4	10	20	5
SSC12-G04	12	1/2	9	25,4	10	24	5
SSC14-G03	14	3/8	7,5	33	10	22	5
SSC14-G04	14	1/2	9,0	32	10	24	5

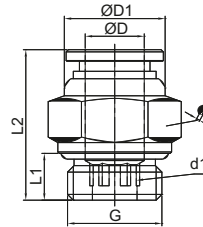

ART. SSC

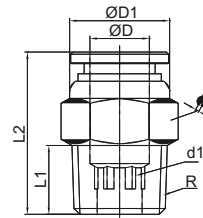

Diritto filetto conico maschio
Straight male tapered adaptor

CODICE	ØD	R	L1	L2	⊙	🔑	🏠
SSC04-01	4	1/8	7,5	16,8	3	10	10
SSC04-02	4	1/4	9,5	21	3	14	10
SSC06-01	6	1/8	7,5	19,3	4	12	10
SSC06-02	6	1/4	9,5	19,8	4	14	10
SSC06-03	6	3/8	10,5	22	4	17	10
SSC06-04	6	1/2	12,5	24	4	21	10
SSC08-01	8	1/8	7,5	23,7	6	14	10
SSC08-02	8	1/4	9,5	22,2	6	14	10
SSC08-03	8	3/8	10,5	22,5	6	17	10
SSC08-04	8	1/2	12,5	24	6	21	10
SSC10-02	10	1/4	9,5	26,4	8	17	10
SSC10-03	10	3/8	10,5	22,9	8	17	5
SSC10-04	10	1/2	12,5	25	8	21	5
SSC12-02	12	1/4	9,5	31,3	8	21	5
SSC12-03	12	3/8	10,5	26,4	10	20	5
SSC12-04	12	1/2	13,5	26,4	10	21	5
SSC14-04	14	1/2	12,5	33	10	22	5



ART. SSCF-G

 Diritto femmina (filetto cilindrico)
 Straight female adaptor (parallel thread)

CODICE	ØD	G	L1	L2		
SSCF04-M5	4	M5	20,2	10,5	12	10
SSCF04-01	4	1/8	21,2	10,5	12	10
SSCF04-02	4	1/4	21	10,5	17	10
SSCF06-01	6	1/8	21,6	12,5	14	10
SSCF06-02	6	1/4	21	12,5	17	10
SSCF08-01	8	1/8	25	14,5	17	10
SSCF08-02	8	1/4	24,5	14,5	17	10

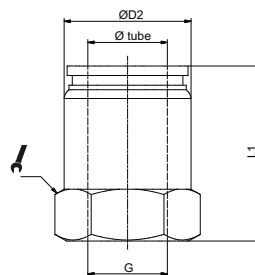

ART. SSH

 Anello semplice girevole con asta conico
 Complete single banjo tapered

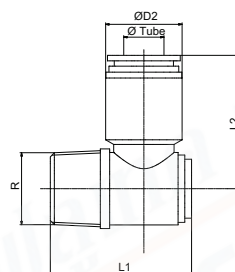
CODICE	ØD	R	L1	L2	D2	
SSH04-01	4	1/8	25,5	26	10,5	10
SSH06-01	6	1/8	25,5	26	12,5	10
SSH06-02	6	1/4	28	28	12,5	10
SSH08-01	8	1/8	25,5	29	14,5	10
SSH08-02	8	1/4	28	30	14,5	10
SSH08-03	8	3/8	33,2	33	14,5	10
SSH10-02	10	1/4	28	32	17,5	10
SSH10-03	10	3/8	33,2	35	17,5	10
SSH12-02	12	1/4	28	34	20,5	10
SSH12-03	12	3/8	33,2	36,5	20,5	10
SSH12-04	12	1/2	37,2	38	20,5	10

ART. SSL-G

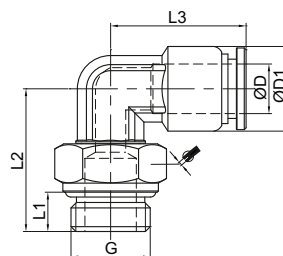

 Gomito girevole filetto cilindrico maschio
 Swivel L male parallel adaptor

CODICE	ØD	G	L1	L2	L3	ØD1		
SSL04-M5	4	M5	4	17,5	18,3	10	10	10
SSL04-G01	4	1/8	5,5	20	18,3	10	13	10
SSL04-G02	4	1/4	6,5	27,5	23	10,5	14	10
SSL06-M5	6	M5	4	17,5	20,3	12	10	10
SSL06-G01	6	1/8	5,5	22	20,3	12	13	10
SSL06-G02	6	1/4	6,5	23	20,3	12	16	10
SSL06-G03	6	3/8	7,5	28	24	12,5	17	10
SSL08-G01	8	1/8	5,5	22,5	22,3	14	13	10
SSL08-G02	8	1/4	6,5	23,5	22,3	14	16	5
SSL08-G03	8	3/8	7,5	28	27	14,5	17	5
SSL10-G01	10	1/8	5,5	32,3	30,5	17,5	17	5
SSL10-G02	10	1/4	6,5	31	26,4	17	17	5
SSL10-G03	10	3/8	7,5	28,5	26,4	17	20	5
SSL10-G04	10	1/2	9	31	30,5	17,5	21	5
SSL12-G02	12	1/4	6,5	30,5	34	20,5	14	5
SSL12-G03	12	3/8	7,5	30	29,4	20	20	5
SSL12-G04	12	1/2	9	30,5	29,4	20	24	5
SSL14-G03	14	3/8	7,5	33	37	22	17	5
SSL14-G04	12	1/2	9	35	37	22	21	5



ART. SSL

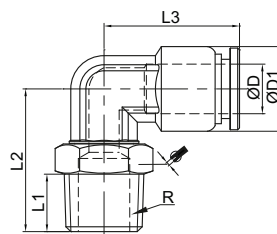

Gomito girevole filetto conico maschio
Swivel L tapered adaptor

CODICE	ØD	R	L1	L2	L3	ØD1		
SSL04-01	4	1/8	7,5	20	18,3	10	12	10
SSL04-02	4	1/4	9,5	27,5	23	10,5	14	10
SSL06-01	6	1/8	7,5	23	20,3	12	12	10
SSL06-02	6	1/4	9,5	23	20,3	12	14	10
SSL06-03	6	3/8	10,5	28	24	12,5	17	10
SSL08-01	8	1/8	7,5	23,5	22,3	14	12	10
SSL08-02	8	1/4	9,5	23,5	22,3	14	14	5
SSL08-03	8	3/8	10,5	28	27	14,5	17	10
SSL10-02	10	1/4	9,5	33	26,4	17	17	5
SSL10-03	10	3/8	10,5	30	26,4	17	17	5
SSL12-02	12	1/4	9,5	30,5	34	20,5	14	5
SSL12-03	12	3/8	10,5	31,5	29,4	20	17	5
SSL12-04	12	1/2	13,5	33,5	29,4	20	21	5



ART. SSLF

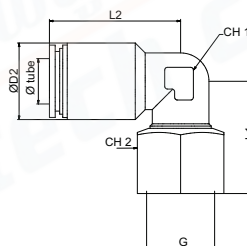

Gomito girevole femmina (filetto cilindrico)
Female swivel L adaptor (parallel thread)

CODICE	ØD	G	L1	L2	D2			
SSLF04-01	4	1/8	25,5	23	10,5	9,2	10	10
SSLF06-01	6	1/8	27	24	12,5	9,2	14	10
SSLF06-02	6	1/4	28	24	12,5	9,2	17	10
SSLF08-01	8	1/8	27	27	14,5	11,2	14	10
SSLF08-02	8	1/4	28	27	14,5	11,2	17	10



ART. SSB-G

T centrale girevole filetto cilindrico
Swivel male stud T parallel

CODICE	ØD	G	L1	L2	L3	ØD1		
SSB04-M5	4	M5	4	17,5	36,6	10	10	10
SSB04-G01	4	1/8	5,5	20	36,6	10	13	10
SSB06-M5	6	M5	4	17,5	40,6	12	10	5
SSB06-G01	6	1/8	5,5	22	40,6	12	13	5
SSB06-G02	6	1/4	6,5	23	40,6	12	16	5
SSB08-G01	8	1/8	5,5	22,5	44,6	14	13	5
SSB08-G02	8	1/4	6,5	23,5	44,6	14	16	5
SSB10-G02	10	1/4	6,5	31	52,8	17	17	5
SSB10-G03	10	3/8	7,5	28,5	52,8	17	20	5
SSB12-G03	12	3/8	7,5	30	58,8	20	20	5
SSB12-G04	12	1/2	9	30,5	58,8	20	24	5

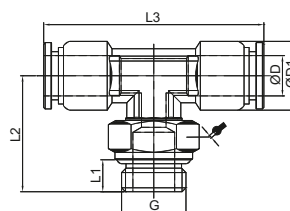

ART. SSB

T centrale girevole filetto conico
Swivel male stud T tapered

CODICE	ØD	R	L1	L2	L3	ØD1		
SSB04-01	4	1/8	7,5	20	36,6	10	12	10
SSB06-01	6	1/8	7,5	23	40,6	12	12	5
SSB06-02	6	1/4	9,5	23	40,6	12	14	5
SSB08-01	8	1/8	7,5	23,5	44,6	14	12	5
SSB08-02	8	1/4	9,5	23,5	44,6	14	14	5
SSB10-02	10	1/4	9,5	33	52,8	17	17	5
SSB10-03	10	3/8	10,5	30	52,8	17	17	5
SSB12-03	12	3/8	10,5	31,5	58,8	20	17	5
SSB12-04	12	1/2	13,5	33,5	58,8	20	21	5

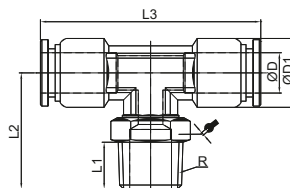

ART. SSGJ

Riduzione con codolo
Plug-in reducer

CODICE	ØD	D1	D2	L1	
SSGJ06-04	4	10,5	6	41	10
SSGJ08-06	6	12,5	8	44	10
SSGJ08-04	4	10,5	8	43	10
SSGJ10-08	8	14,5	10	47	10
SSGJ10-06	6	12,5	10	47	10
SSGJ12-10	10	17,5	12	53	10
SSGJ12-08	8	14,5	12	52	10
SSGJ14-10	10	17,5	14	56	10

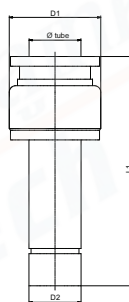

ART. SSM

Passaparete innestabile
Bulkhead connector

CODICE	ØD	ØD1	L	L1 max	M		
SSM04	4	10	27	8	M12x1	14	10
SSM06	6	12	29,5	8	M14x1	17	10
SSM08	8	14	32,5	8,5	M16x1	19	5
SSM10	10	17	36,8	9,5	M20x1	24	5
SSM12	12	20	39,8	11,5	M22x1	26	5
SSM14	14	24	42	17	M24x1	27	5

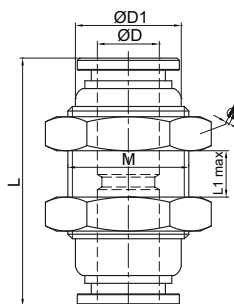

ART. SSU

Dritto innestabile uguale
Equal straight connector

CODICE	ØD	ØD1	L	
SSU04	4	11	27	10
SSU06	6	13	29,5	10
SSU08	8	15	32,5	10
SSU10	10	18	36,8	5
SSU12	12	21	39,8	5
SSU14	14	22	42	5

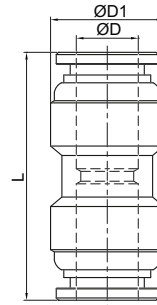

ART. SSG

Dritto innestabile riduzione
Reducer straight connector

CODICE	ØD1	ØD2	D1	D2	L1	
SSG04-06	4	6	10,5	12,5	30,6	10
SSG06-08	6	8	12,5	14,5	32,8	10
SSG08-10	8	10	14,5	17,5	35	10
SSG10-12	10	12	17,5	20,5	38,2	10

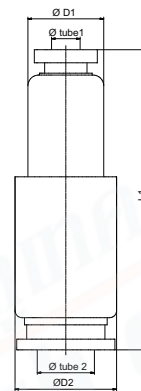

ART. SSV

Gomito innestabile
L connector

CODICE	ØD	ØD1	L	
SSV04	4	10	18,3	10
SSV06	6	12	20,3	10
SSV08	8	14	22,3	10
SSV10	10	17	26,4	5
SSV12	12	20	29,4	5
SSV14	14	22	37	5

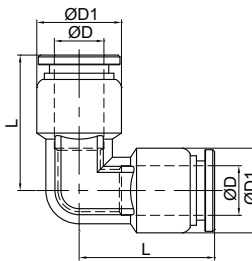

ART. SSE

T innestabile
T connector

CODICE	ØD	ØD1	L	L1	
SSE04	4	10	18,3	36,6	10
SSE06	6	12	20,3	40,6	5
SSE08	8	14	22,3	44,6	5
SSE10	10	17	26,4	52,8	5
SSE12	12	20	29,4	58,8	5
SSE14	14	14	37	74	5

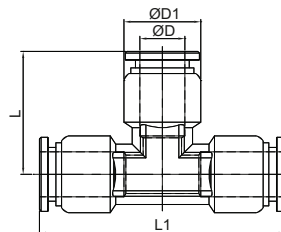

ART. SSY

Y innestabile
Y connector

CODICE	ØD	L1	L2	D2		
SSY04	4	36	14	11		10
SSY06	6	37,5	16	13		10
SSY08	8	41,3	18	15		10
SSY10	10	44,3	21	18		10
SSY12	12	51	24	21		10

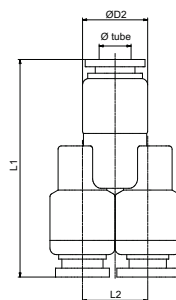

ART. SSP

Tappo
Plug

CODICE	D1	D2	L1			
SSP04	6	4	28			10
SSP06	8	6	33			10
SSP08	10	8	37			10
SSP10	12	10	42			10
SSP12	14	12	44			10
SSP14	16	14	46			10

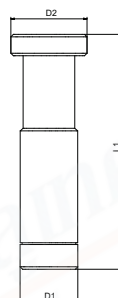

ART. SSN-G

Regolatore di flusso per cilindro girevole
Swivel flow regulator for cylinder

CODICE	ØD	G	L1	L2	L3	D2		
SSN04-G01	4	1/8	34,5	28	7,5	10,5	12	10
SSN04-G02	4	1/4	43	28	9,5	10,5	14	10
SSN06-G01	6	1/8	34,5	28	7,5	12,5	12	10
SSN06-G02	6	1/4	43	28	9,5	12,5	14	10
SSN08-G01	8	1/8	34,5	30	7,5	14,5	12	10
SSN08-G02	8	1/4	43	30	9,5	14,5	14	10
SSN08-G03	8	3/8	47,3	33	10,5	14,5	19	10
SSN08-G04	8	1/2	51	33	12,5	14,5	22	10
SSN10-G02	10	1/4	43	32,5	9,5	17,5	14	10
SSN10-G03	10	3/8	47,3	35	10,5	17,5	19	10
SSN10-G04	10	1/2	51	35	12,5	17,5	22	10
SSN12-G02	12	1/4	43	36	9,5	20,5	14	10
SSN12-G03	12	3/8	47,3	38	10,5	20,5	19	10
SSN12-G04	12	1/2	51	38	12,5	20,5	22	10

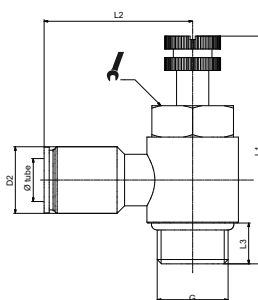

BREVE DESCRIZIONE

I raccordi automatici della nostra serie inox SS sono “oil free” e realizzati in conformità agli standard di qualità secondo le normative ISO di riferimento e rispondono alle seguenti specifiche tecniche e applicative.

SHORT DESCRIPTION

The stainless steel push-in fittings “SS” series are “oil free” and manufactured according to the ISO norms of reference, and suitable for the following technical and applicative specifications.

SCHEMA TECNICA TECHNICAL SHEET

FLUIDI UTILIZZABILI <i>EMPLOYABLE FLUIDS</i>		Aria compressa, acqua, vapore (per altri fluidi sentire il nostro Ufficio Tecnico) <i>Compressed air, water, steam (for different fluid pls contact our Technical Dept.)</i>
APPLICAZIONI <i>APPLICATIONS</i>		Pneumatica applicata a settori industriali quali: medicale, chimico e alimentare. In generale ove siano richiesti requisiti di anti-corrosione, resistenza agli acidi e temperature elevate. <i>Pneumatic equipments which are applied widely in the range of Industry such as food service industry, chemical industry and medical industry. In general where required to ensure anti-corrosion and acid resistant, or usage at high temperature.</i>
TUBI CONSIGLIATI <i>SUGGESTED TUBES</i>		TPU (Poliuretano), PA11/PA12 (Poliammide), TPE (Polietilene), TCO (Copoliestere) <i>TPU (Polyurethane), PA11/PA12 (Polyamide), TPE (Polyethylene), TCO (Copolyester)</i>
TOLLERANZE TUBI <i>TUBES TOLERANCES</i>		Diam. da 4 a 10 mm +/- 0,05 Diam. da 12 mm +/- 0,1 <i>Diam. between 4 and 10 mm +/- 0,05 Diam. from 12 mm +/- 0,1</i>
VALORI LIMITE CONSIGLIATI <i>RECOMMENDED LIMIT VALUES</i>	TEMPERATURE <i>TEMPERATURES</i>	Le temperature di esercizio sono comprese in un campo fra -20°C e +120°C. <i>The working temperatures range is between -20°C and +120°C</i>
	PRESSIONI <i>PRESSURES</i>	Le pressioni di esercizio sono comprese in un campo fra 0 e 1,2MPa (0-12bar). <i>The working pressure range is between 0 and 1,2MPa (0-12Bar).</i>
	NOTA <i>NOTE</i>	Per dati più puntuali consultare il catalogo tecnico del proprio fornitore di tubi. <i>For more complete informations pls read the technical catalogue of your tube supplier.</i>
FILETTATURE <i>THREAD TYPE</i>		BSP cilindrica UNI-ISO 228; BSP conica UNI-ISO 7; Metrica ISO/R 262. <i>BSP parallell UNI-ISO 228; BSP tapered UNI-ISO 7; Metric ISO/R 262</i>
MATERIALI <i>MATERIALS</i>	corpo, spintore, distanziale, sottomolla <i>body, sleeve, collar and back ring</i>	Acciaio inox SUS316 <i>Stainless Steel SUS316</i>
	pinza <i>spring</i>	Acciaio Inox SUS301 <i>Stainless Steel SUS301</i>
	guarnizioni tenuta <i>seals</i>	Viton/FKM/FPM <i>FPM/FKM/Viton</i>
NOTA IMPORTANTE <i>IMPORTANT NOTE</i>		La materia prima è amagnetica, comunque dopo la lavorazione a freddo, una piccola quantità di austenite potrebbe essere trasformata in martensite, che potrebbe essere molto debolmente magnetica. <i>The raw material is non-magnetic, however after cold working, a small amount of austenite could be transformed into martensite, which could be very weakly magnetic.</i>

Esito dei test di compatibilità alle specifiche FDA effettuati da **TUV NORD** per conto del produttore

	TEST REPORT N.	DATA	DURATA (GIORNI)	COMPONENTE	MATERIALE	OBBIETTIVO DEL TEST
A	TRHZ1208110	06/08/2012	6	GUARNIZIONE DI TENUTA	VITON FPM FLUORO-RUBBER (FKM)	CONFORMITA' ALLE SPECIFICHE FDA PER DETERMINARE IL GRADO DI ESTRAZIONE DI CLOROFORMIO SOLUBILE (ppm) NELLE GUARNIZIONI DI TENUTA PER CHIUSURA DI CONTENITORI ALIMENTARI
B	TRHZ1208111	06/08/2012	6	RACCORDO AD L MOD. SSV	ACCIAIO INOSSIDABILE SUS316L	DETERMINAZIONE DEL CONTENUTO TOTALE DI CROMO
C	TRHZ1208112	06/08/2012	6	RACCORDO DIRITTO MOD. SSC-G	ACCIAIO INOSSIDABILE SUS316L	DETERMINAZIONE DEL CONTENUTO TOTALE DI CROMO

	METODO DEL TEST (ref. FDA 21 CFR 177.1210)	RISULTATO	CONCLUSIONI
A	IMMERSIONE PER 2 ORE IN ACQUA DISTILLATA A 212°F	VALORE RILEVATO 13,0 VALORE LIMITE 50,0	IL RISULTATO DEL TEST SUI CAMPIONI PRESENTATI SONO CONFORMI ALLE SPECIFICHE FDA PER DETERMINARE LA QUANTITA' DI ESTRATTIVI DI CLOROFORMIO SOLUBILE AMMESSI
	IMMERSIONE PER 2 ORE IN ALCOHOL 8% A 212°F	VALORE RILEVATO 7,0 VALORE LIMITE 50,0	
	IMMERSIONE PER 2 ORE IN EPTANO NORMALE (N-EPTANO) A 150 °F	VALORE RILEVATO 11,5 VALORE LIMITE 50,0	
B	ANALISI VOLUMETRICA (TITOLAZIONE)	VALORE RILEVATO 16,38% VALORE RICHIESTO $\geq 10,5\%$	IL RISULTATO DEL TEST SUL CAMPIONE PRESENTATO DETERMINA CHE ESSO E' IDONEO AL CONTATTO CON GLI ALIMENTI
C	ANALISI VOLUMETRICA (TITOLAZIONE)	VALORE RILEVATO 17,18% VALORE RICHIESTO $\geq 10,5\%$	IL RISULTATO DEL TEST SUL CAMPIONE PRESENTATO DETERMINA CHE ESSO E' IDONEO AL CONTATTO CON GLI ALIMENTI



 Test results to FDA specifications compatibility, made by **TUV NORD** on behalf of the manufacturer

	TEST REPORT N.	DATE	PERIOD (DAYS)	ITEM	MAIN MATERIAL	TEST PURPOSE
A	TRHZ1208110	06/08/2012	6	SEAL RING	FPM FLUORORUBBER VITON (FKM)	THE COMPLIANCE WITH THE FOOD AND DRUG ADMINISTRATION REGULATIONS FOR DETERMINING THE AMOUNT OF CHLOROFORM-SOLUBLE EXTRACTIVES (ppm) FROM CLOSURES WITH SEALING GASKETS FOR FOOD CONTAINERS
B	TRHZ1208111	06/08/2012	6	ELBOW FITTING MOD. SSV	STAINLESS STEEL SUS316L	TO DETERMINE TOTAL CHROMIUM CONTENT IN THE SUBMITTED SAMPLE
C	TRHZ1208112	06/08/2012	6	STRAIGHT FITTING MOD. SSC-G	STAINLESS STEEL SUS316L	TO DETERMINE TOTAL CHROMIUM CONTENT IN THE SUBMITTED SAMPLE

	TEST METHOD (ref. FDA 21 CFR 177.1210)	TEST RESULT	CONCLUSION
A	IMMERSION FOR 2 HOURS IN DISTILLED WATER AT 212 ° F	DETECTED VALUE 13,0 MAX PERMISSIBLE 50,0	WHEN TESTED AS SPECIFIED, THE TEST RESULTS OF THE SUBMITTED SAMPLE COMPLY WITH THE FDA SPECIFICATIONS FOR DETERMINING THE AMOUNT OF CHLOROFORM-SOLUBLE EXTRACTIVES FOR CLOSURES (CLOS)
	IMMERSION FOR 2 HOURS IN ALCOHOL 8% AT 212°F	DETECTED VALUE 7,0 MAX PERMISSIBLE 50,0	
	IMMERSION FOR 2 HOURS IN n-HEPTANE AT 150°F	DETECTED VALUE 11,5 MAX PERMISSIBLE 50,0	
B	TITRATION METHOD	DETECTED VALUE 16,38% REQUIREMENT $\geq 10,5\%$	WHEN TESTED AS SPECIFIED, THE TEST RESULTS OF THE SUBMITTED SAMPLE IS SUITABLE FOR CONTACT WITH FOOD
C	TITRATION METHOD	DETECTED VALUE 17,18% REQUIREMENT $\geq 10,5\%$	WHEN TESTED AS SPECIFIED, THE TEST RESULTS OF THE SUBMITTED SAMPLE IS SUITABLE FOR CONTACT WITH FOOD

ART. RX102

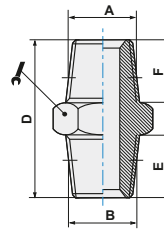

Niplo conico
Taper nipple

CODICE	A	B	D	E	F		
RX1021818	G1/8	G1/8	21	7,5	7,5	14	10
RX1021814	G1/8	G1/4	23	7,5	9,5	14	10
RX1021414	G1/4	G1/4	25	9,5	9,5	17	10
RX1021438	G1/4	G3/8	25	9,5	10,5	17	10
RX1021412	G1/4	G1/2	26,5	13	9,5	24	5
RX1023838	G3/8	G3/8	26,5	10,5	10,5	21	10
RX1023812	G3/8	G1/2	29	10,5	13	24	5
RX1021212	G1/2	G1/2	31	13	13	21	5



ART. RX103

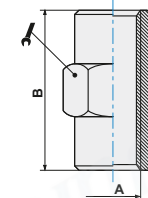

Manicotto filettato
Sleeve

CODICE	A	B					
RX10318	G1/8	17				14	10
RX10314	G1/4	23				17	10
RX10338	G3/8	25				21	5
RX10312	G1/2	28				24	5



ART. RX104

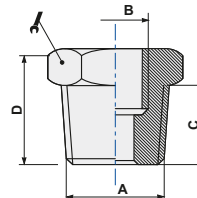

Riduzione M/F conica
Taper reducer

CODICE	A	B	C	D			
RX1041418	G1/4	G1/8	10	16		17	10
RX1043818	G3/8	G1/8	11,5	18		17	10
RX1041218	G1/2	G1/8	12	18		21	5
RX1043814	G3/8	G1/4	11,5	18		21	10
RX1041214	G1/2	G1/4	12	18		24	5
RX1041238	G1/2	G3/8	12	18		24	5



ART. RX104Z

Riduzione M/F cilindrica con O.R.
Parallel reducer with O.R.

CODICE	A	B	C	D			
RX104Z18M5	G1/8	M5	5,5	12,5		14	10
RX104Z1418	G1/4	G1/8	6,5	13,5		17	10
RX104Z3814	G3/8	G1/4	7,5	14,5		21	10

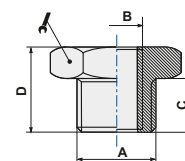

ART. RX107Z

Tappo maschio cilindrico con O.R.
Parallel male plug with O.R.

CODICE	A	B	C				
RX107Z18	G1/8	12,5	5,5			14	10
RX107Z14	G1/4	13,5	6,5			17	10
RX107Z38	G3/8	14,5	7,5			21	5
RX107Z12	G1/2	16	9			24	5

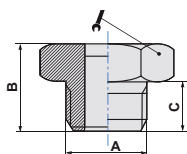

ART. RX109

L F.F.
Female L

CODICE	A	B	C				
RX10918	G1/8	9,5	22,5			11	10
RX10914	G1/4	11,5	25			13	5
RX10938	G3/8	12,5	28			15,6	5
RX10912	G1/2	15	31,5			20,6	10

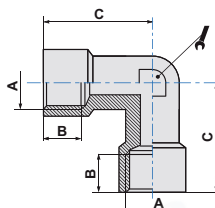

ART. RX110

L M.F.
Male-Female L

CODICE	A	A1	B	B1	C	D		
RX11018	G1/8	G1/8	9,5	7,5	22,5	18,5	11	5
RX11014	G1/4	G1/4	11,5	10	25	22,5	13	5
RX11038	G3/8	G3/8	12,5	11,5	28	25	15,6	5
RX11012	G1/2	G1/2	15	12	31,5	29,5	20,6	5

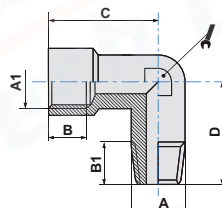

ART. RX111

T F.F.F.
Female T

CODICE	A	B	C	D			
RX11118	G1/8	7,5	7,5	18,5		11	5
RX11114	G1/4	10	25	50		13	5
RX11138	G3/8	11,5	27	58,5		15	5
RX11112	G1/2	12	31	67		20,6	5

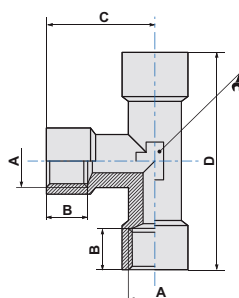

ART. RX112

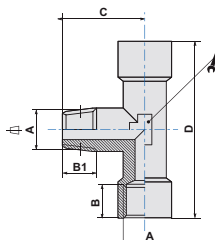

T F.M.F.
Centre male T

CODICE	A	B	B1	C	D		
RX11218	G1/8	7,5	9,5	18,5	45	11	5
RX11214	G1/4	10	11,5	22,5	50	13	5
RX11238	G3/8	11,5	12,5	25	58,5	15,6	5
RX11212	G1/2	12	15	29,5	67	20,6	5



ART. RX115

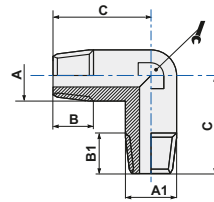

Elle M.M.
Male L

CODICE	A	B	C	A1	B1		
RX11518	G1/8	7,5	17	8,5	7,5	9	10
RX11514	G1/4	10	21	10,5	10	11	5
RX11538	G3/8	10,5	23,5	12,5	10,5	13	5
RX11512	G1/2	13	26,7	15	13	15,6	5



ART. RX301

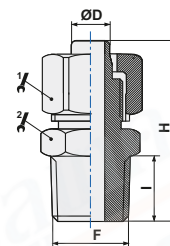

Raccordo diritto maschio conico
Taper straight male adaptor

CODICE	ØD	F	I	H			
RX30106M5	6/4	M5	4	23,7	12	12	10
RX3010618	6/4	G1/8	7,5	25	12	12	10
RX3010614	6/4	G1/4	9,5	27	12	14	10
RX3010818	8/6	G1/8	7,5	26,2	14	14	10
RX3010814	8/6	G1/4	9,5	30,5	17	17	5
RX3011014	10/8	G1/4	10	31,5	17	17	



ART. RX302

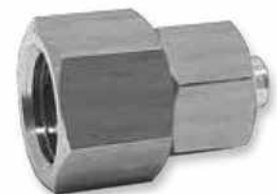
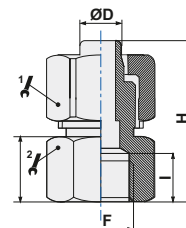

Raccordo diritto femmina
Straight female adaptor

CODICE	ØD	F	I	H	H1			
RX3020618	6/4	G1/8	9,5	23	10,5	12	14	10
RX3020614	6/4	G1/4	11,5	25	12,5	12	17	10
RX3020818	8/6	G1/8	9,5	24	11	14	14	10
RX3020814	8/6	G1/4	11,5	26	12,5	14	17	10



ART. RX303

Raccordo diritto intermedio
Straight connector

CODICE	ØD	L			
RX3030600	6/4	30	12	12	10
RX3030800	8/6	32	14	14	10
RX3031000	10/8	37	17	17	5
RX3031200	12/10	41	19	19	5

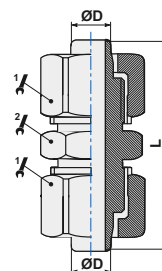

ART. RX305

Raccordo ad L maschio conico
L taper male adaptor

CODICE	ØD	F	I	H	L			
RX3050418	4/2,5	G1/8	8,5	17	16	8	9	10
RX3050618	6/4	G1/8	11	21	21	12	9	10
RX3050614	6/4	G1/4	11	21	21	12	11	10
RX3050818	8/6	G1/8	8,5	18	23	14	11	10
RX3050814	8/6	G1/4	11	22,3	23	14	11	10
RX3051014	10/8	G1/4	11	23,5	25	17	13	5
RX3051038	10/8	G3/8	14	25	25	17	13	5

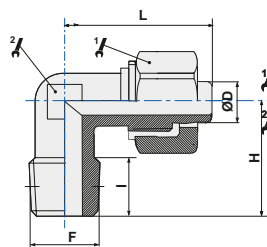

ART. RX306

Raccordo ad L intermedio
L connector

CODICE	ØD	L			
RX3060600	6/4	21	12	9	10
RX3060800	8/6	22,5	14	11	10
RX3061000	10/8	25	17	13	5
RX3061200	12/10	27,5	19	15,5	5

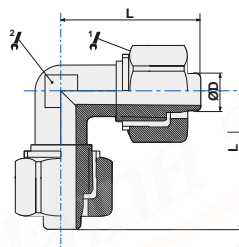

ART. RX307

Raccordo T centrale
Central T adaptor

CODICE	ØD	F	I	H	L			
RX3070618	6/4	G1/8	11,5	22	41,5	12	9	10
RX3070614	6/4	G1/4	9	22	41,5	12	9	5
RX3070818	8/6	G1/8	8,5	18	44,5	14	11	5
RX3070814	8/6	G1/4	12	24	44	14	11	5
RX3071014	10/8	G1/4	11,5	24	50,5	17	13	5

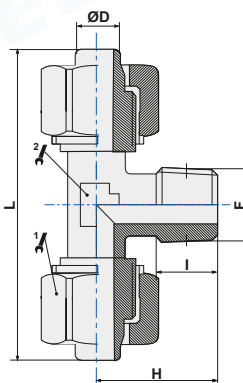

ART. RX309

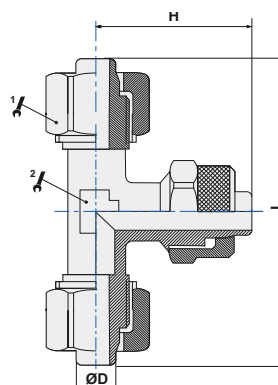

Raccordo T intermedio
connector

CODICE	ØD	H	L			
RX3090600	6/4	20,5	41	12	9	5
RX3090800	8/6	23,5	44,5	14	11	5
RX3091000	10/8	26,5	50,7	17	13	5
RX3091200	12/10	27,5	55,4	19	13	5



ART. RX310

Dado di serraglio
Locking nut

CODICE	ØD	F	H		
RX3100600	6/4	M10x1	10	12	10
RX3100800	8/6	M12x1	10	14	10
RX3101000	10/8	M14x1	12	17	10

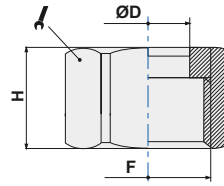

 บริษัท ฟลูเทค จำกัด
 Flu-tech co.,ltd
 Fluid Control Specialists

BREVE DESCRIZIONE

I raccordi accessori della nostra serie inox RX sono “oil free” e realizzati in conformità agli standard di qualità secondo le normative ISO di riferimento, e rispondono alle seguenti specifiche tecniche e applicative.

SHORT DESCRIPTION

The stainless steel accessory fittings “RX” series are “oil free” and manufactured according to the ISO norms of reference, and suitable for the following technical and applicative specifications.

SCHEDA TECNICA TECHNICAL SHEET

FLUIDI UTILIZZABILI <i>EMPLOYABLE FLUIDS</i>		Aria compressa, alcuni liquidi (per altri fluidi sentire il nostro Ufficio Tecnico) <i>Compressed air, some liquids (for different fluid pls contact our Technical Dept.)</i>
APPLICAZIONI <i>APPLICATIONS</i>		Pneumatica applicata a settori industriali quali: medicale, chimico e alimentare. In generale ove siano richiesti requisiti di anti-corrosione, resistenza agli acidi e temperature elevate. <i>Pneumatic equipments which are applied widely in the range of Industry such as food service industry, chemical industry and medical industry. In general where required to ensure anti-corrosion and acid resistant, or usage at high temperature.</i>
TUBI CONSIGLIATI PER LA SERIE A CALZAMENTO <i>SUGGESTED TUBES FOR THE QUICK SERIES</i>		4x2,5; 6x4; 8x6; 10x8; 12x10; 14x11; 16x13;
VALORI LIMITE CONSIGLIATI <i>RECOMMENDED LIMIT VALUES</i>	TEMPERATURE <i>TEMPERATURES</i>	Le temperature di esercizio sono comprese in un campo fra -20°C e +120°C. <i>The working temperatures range is between -20°C and +120°C</i>
	PRESSIONE DI ESERCIZIO <i>WORKING PRESSURES</i>	La pressione di esercizio dipende dal tipo di tubo impegnato, valore massimo 25bar. <i>The working pressure depends on the type of employed pipe, maximum value 25bar</i>
FILETTATURE <i>THREAD TYPE</i>		BSP cilindrica UNI-ISO 228; BSP conica UNI-ISO 7; Metrica ISO/R 262. <i>BSP parallel UNI-ISO 228; BSP tapered UNI-ISO 7; Metric ISO/R 262</i>
MATERIALI <i>MATERIALS</i>	corpo e dado serie a calzamento <i>body and nut quick series</i>	Acciaio inox SUS316 <i>Acciaio inox SUS316</i>
	corpo serie di linea <i>body transition series</i>	Acciaio inox SUS316 <i>Acciaio inox SUS316</i>
	guarnizioni tenuta <i>seals</i>	Viton/FKM/FPM <i>FPM/FKM/Viton</i>
NOTA IMPORTANTE <i>IMPORTANT NOTE</i>		La materia prima è amagnetica, comunque dopo la lavorazione a freddo, una piccola quantità di austenite potrebbe essere trasformata in martensite, che potrebbe essere molto debolmente magnetica. <i>The raw material is non-magnetic, however after cold working, a small amount of austenite could be transformed into martensite, which could be very weakly magnetic.</i>